



This is a digital copy of a book that was preserved for generations on library shelves before it was carefully scanned by Google as part of a project to make the world's books discoverable online.

It has survived long enough for the copyright to expire and the book to enter the public domain. A public domain book is one that was never subject to copyright or whose legal copyright term has expired. Whether a book is in the public domain may vary country to country. Public domain books are our gateways to the past, representing a wealth of history, culture and knowledge that's often difficult to discover.

Marks, notations and other marginalia present in the original volume will appear in this file - a reminder of this book's long journey from the publisher to a library and finally to you.

Usage guidelines

Google is proud to partner with libraries to digitize public domain materials and make them widely accessible. Public domain books belong to the public and we are merely their custodians. Nevertheless, this work is expensive, so in order to keep providing this resource, we have taken steps to prevent abuse by commercial parties, including placing technical restrictions on automated querying.

We also ask that you:

- + *Make non-commercial use of the files* We designed Google Book Search for use by individuals, and we request that you use these files for personal, non-commercial purposes.
- + *Refrain from automated querying* Do not send automated queries of any sort to Google's system: If you are conducting research on machine translation, optical character recognition or other areas where access to a large amount of text is helpful, please contact us. We encourage the use of public domain materials for these purposes and may be able to help.
- + *Maintain attribution* The Google "watermark" you see on each file is essential for informing people about this project and helping them find additional materials through Google Book Search. Please do not remove it.
- + *Keep it legal* Whatever your use, remember that you are responsible for ensuring that what you are doing is legal. Do not assume that just because we believe a book is in the public domain for users in the United States, that the work is also in the public domain for users in other countries. Whether a book is still in copyright varies from country to country, and we can't offer guidance on whether any specific use of any specific book is allowed. Please do not assume that a book's appearance in Google Book Search means it can be used in any manner anywhere in the world. Copyright infringement liability can be quite severe.

About Google Book Search

Google's mission is to organize the world's information and to make it universally accessible and useful. Google Book Search helps readers discover the world's books while helping authors and publishers reach new audiences. You can search through the full text of this book on the web at <http://books.google.com/>

The automotive manufacturer

Transportation

Library

1

R231

v. 58

The Hub 81466.

CARRIAGES - AUTOMOBILES - WAGONS - TRUCKS



TRADE NEWS PUBLISHING CO.
EDISON BUILDING, ELM & DUANE STS.,
NEW YORK

SHELDON AXLES AND SPRINGS

**For Horse-Drawn and Power-Propelled
Vehicles of All Kinds**

JUST ENOUGH BETTER THAN OTHERS TO BE NOTICEABLE

When you specify "Sheldon" you are not experimenting with experiments, but are getting Axles and Springs with years of manufacturing experience back of them—Axles and Springs that are selected for important work where conditions make reliability supremely important

SHELDON AXLE AND SPRING COMPANY, WILKES-BARRE, PA.

LARGEST AXLE AND SPRING FACTORY IN THE WORLD

WILCOX

FINE
FINISHED
FORGED

**CARRIAGE HARDWARE
AND GEAR IRONS**

Write for Prices and Catalog

The D. Wilcox Mfg. Co.

MECHANICSBURG, PA.

The WEST Hydraulic Tire Setter

WILL CUT DOWN EXPENSE

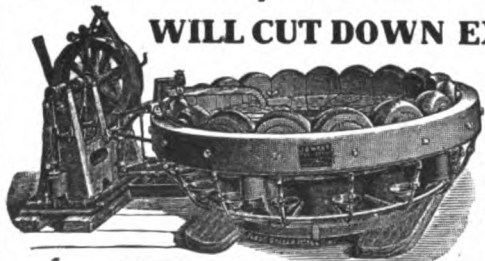

Tires set cold in one minute. This machine saves time—does the work better and quicker, does a way with burned streaks. Only necessary to measure one wheel in a lot. Does not char the rim, and

thus make the tire loosen prematurely. Saves resandpapering of wheels. This machine is now increasing the profits of many manufacturers. Send for catalog and read about it.

WEST TIRE SETTER CO., ROCHESTER, NEW YORK

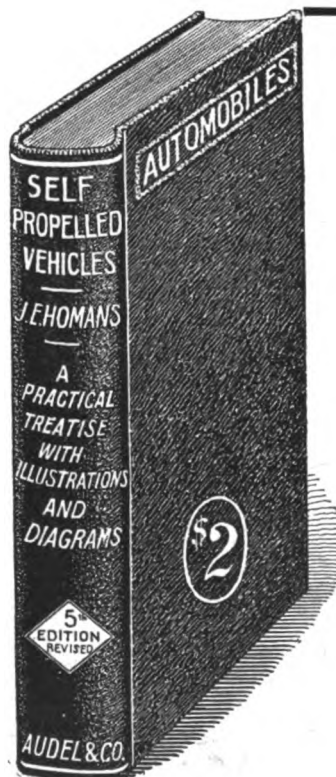

"Self-Propelled Vehicles"

Fifth Edition, Revised.

A practical treatise on the theory, construction, operation, care and management of all kinds of Automobiles.

By

JAMES E. HOMANS, A.M.

Contains 608 pages and upwards of 500 illustrations and diagrams, giving the essential details of construction and many important points on the successful operation of the various types of motor carriages driven by steam, gasoline and electricity.

This work is now the accepted standard, explaining the principles of construction and operation in a clear and helpful way. This book will be sent postpaid to any address in the United States, Mexico or Canada upon receipt of \$2.00.

Address

Trade News Publishing Co.

Edison Bldg., Cor. Elm and Duane Sts., New York

**Convince Yourself
IN YOUR OWN FACTORY THAT**



"Motor Quality IS Superior to Coated Splits."
That it is stronger, more uniform in quality throughout and works and wears better, and is more economical.

Fabrikoid has been adopted by the majority of the largest vehicle makers in the country as the standard upholstery material, and is giving perfect satisfaction.

Get in line and save time, money and worry by using Fabrikoid in every case where real grain leather is prohibitive.

State your line and send for samples today

DU PONT FABRIKOID CO.

Wilmington, Delaware

Works at Newburgh, N. Y.

Canadian Factory and Sales Office; TORONTO

**WILLEY'S
COLORS**

The **RECOGNIZED STANDARD**



C. A. WILLEY CO.

COLOR GRINDERS

and Manufacturers of Specialties in

CARRIAGE, AUTOMOBILE AND CAR

PAINTS

COLORS, VARNISHES, ETC.

HUNTER'S POINT, NEW YORK CITY

THE F. H. LAWSON CO.

CINCINNATI, O.

Manufacturers of

Metal Buggy Seats

FLEUR DE LIS PATTERN



NEW STYLES—ALL SIZES

STRONGEST—NEATEST—BEST

No Solder Used

**YOUR VEHICLE SELLS WHEN EQUIPPED WITH
LAWSON'S METAL SEATS**

Write for Prices



Reg. U. S. Pat. Off.

Moleskin Quality

The Best Leather Substitute

All the
Standard Leather Grains, Colors and Finishes

GUARANTEED

Against Cracking, Peeling or Wearing Down
to the Cloth Backing

WRITE FOR SAMPLES

O'BANNON CORPORATION

200 Fifth Avenue, New York City

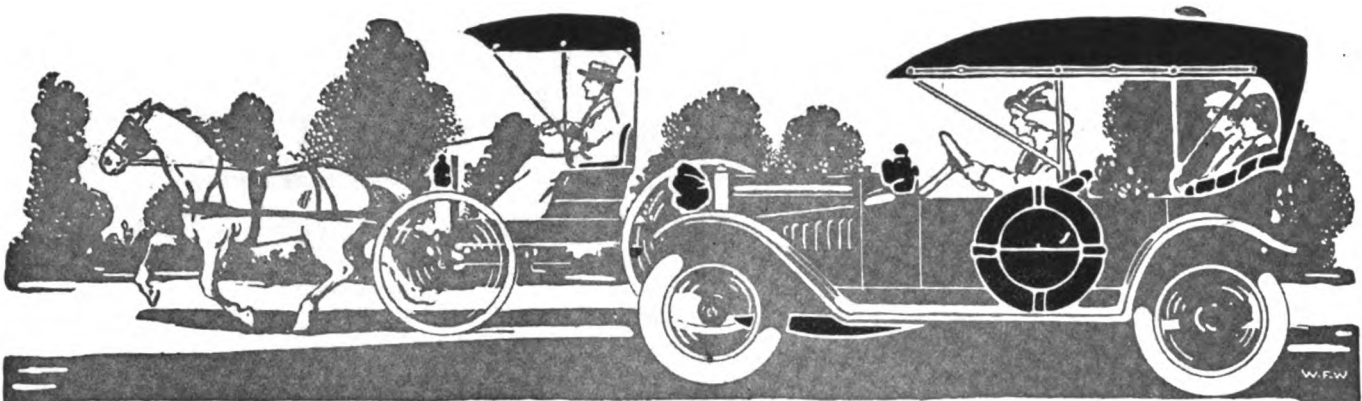

The Leading Leather Substitute For Carriage and Auto Trade

When you need a leather substitute, join the other progressive carriage and automobile manufacturers and select the leading leather substitute—

MERITAS

LEATHER CLOTH

A leather substitute is but a substitute after all—but Meritas leather cloth is made and finished to withstand the hardest wear and handling.

Meritas Leather Cloth is durable, of non-cracking finish and guaranteed perfect by our trademark stamped on the back of every yard. You will like the selection of colors and the lasting finish of this serviceable leather substitute.

Meritas Leather Cloth is made in muslin, duck and drill; dull or glazed; smooth or grained; in black and colors.

Learn more about this leading leather substitute by writing for sample book—sent on request.

Write
for
sample
book of
MERITAS
LEATHER CLOTH
NOW

The Standard Oil Cloth Co., Inc.

320 Broadway, New York

The Hub

Vol. LVIII

APRIL, 1916

No. 1

Published Monthly by

THE TRADE NEWS PUBLISHING CO. OF N. Y.

J. H. WRIGHT, *President* G. A. TANNER, *Secretary and Treasurer*
EDISON BUILDING, COR. ELM AND DUANE STS., NEW YORK

Other Publications of Trade News Publishing Co.:

HARNESS (monthly).....per year, \$1.00
AMERICAN HARNESS AND SADDLERY DIRECTORY
(annually), per copy, \$5.00

THE HUB is published monthly in the interest of employers and workmen connected with the manufacture of Carriages, Wagons, Sleighs, Automobiles and the Accessory trades, and also in the interest of Dealers.

Subscription price for the United States, Mexico, Cuba, Porto Rico, Guam, the Philippines, and the Hawaiian Islands, \$2.00; Canada, \$2.50; payable strictly in advance. Single copies, 25 cents. Remittances at risk of subscriber, unless by registered letter, or by draft, check, express or post-office order, payable to the order of THE TRADE NEWS PUBLISHING CO.

For advertising rates, apply to the Publishers. Advertisements must be acceptable in every respect. Copy for new advertisements must be received by the 25th of the preceding month, and requests to alter or discontinue advertisements must be received before the 12th day of the preceding month to insure attention in the following number. All communications must be accompanied by the full name and address of writer.

FOREIGN REPRESENTATIVES:

FRANCE—L. Dupont, publisher of *Le Guide des Carrossiers*, 78 Rue Boissiere, Paris. Subscription price, 15 francs, postpaid.

GERMANY—Gustave Miesen, Bohn a Rh. Subscription price, 12 marks, postpaid.

ENGLAND—Thomas Mattison, "Floriana," Hillside avenue, Bitterne Park, Southampton. Subscription price, 12 shillings, postpaid.

Entered in the New York Post Office as Second-class Matter

Tremendous Car Production

A total of 328,366 cars were turned out in the zone comprising Detroit, Toledo, Flint, Jackson and Lansing for the first three months of 1916. Detroit lead with 238,076 cars, of these 149,005 being Fords. All of the automobile factories in 1915 produced 106,000 cars, so that Detroit alone more than tripled the entire production of the country during this period.

Of the 149,005 Fords produced in this period, 44,365 were built in January, 46,311 in February, and 58,329 in March. These figures leave no doubt that the company will succeed in accomplishing what it set out to do in the production of 500,000 cars this year.

The Overland plant, the second largest automobile producer in the world, built 12,393 cars in January, 15,292 in February, and 19,780 in March, or a total of 47,465 for the period.

In 1915, for this period, the Toledo plant turned out 17,245 machines, so that March alone this year produced more than the first three months of 1915.

For the first quarter this year Saxon produced 6,391 against 2,591 last year, March with its production of 2,604 exceeding the entire quarter of last year.

Packard claims a gain of 300 per cent and Studebaker

an increase of 100 per cent over last year's first quarter.

There have been 26,563 Cadillac eights produced since that company began making this type, a truly wonderful showing for a high-priced car.

Reo claims a large increase in production, and Oakland says that its output is better by 400 per cent than last year.

Maxwell has reached a monthly output of 8,000 cars, and Paige-Detroit claims production facilities of 175 cars a day.

During the automobile show in New York it was predicted that the total output of the country would reach a million cars this year. At the end of the first quarter these five cities alone produced nearly a third of this stupendous figure, and it is now thought that the output will reach 1,400,000 cars.

Trade of the Country

America's exports and imports both were greater in February than in any previous month in the country's history. Figures assembled in the Bureau of Foreign and Domestic Commerce show exports had a total value of \$409,836,525, exceeding by \$50,000,000 the record set last December. Imports reached \$194,000,000.

Total exports for the first eight months of the fiscal year were valued at \$2,856,301,570, indicating in the opinion of Department of Commerce officials, a \$4,000,000,000 total for the year. A favorable trade balance of \$1,295,217,462 is shown for the last eight months.

Gold imports in February are given as \$6,000,000, and for the eight months \$328,054,000.

Some Startling Figures

The slack business methods of the great majority of corporations doing business in the United States are revealed in figures given out by Edward N. Hurley, vice chairman of the Federal Trade Commission in an address delivered before a number of trade organizations appealing for better business methods. He said:

"The Federal Trade Commission has been in existence one year and after surveying the field we found from a preliminary investigation that 200,000 corporations out of a total of 260,000 engaged in the manufacturing and mercantile business of the United States were eking out an existence; 100,000 of them did not earn a penny. Out of 60,000 successful corporations doing a business of \$100,000 a year over 30,000 charged off no depreciation whatever. Only 10 per cent of our manufacturers and merchants know the actual cost to manufacture and sell their products; 40 per cent estimate what their costs are, and 50 per cent have no method, but price their goods arbitrarily. Most of the manufacturers and merchants who do not know what their goods cost are basing their selling

price on what their competitors sell for and with only this knowledge for a basis they are frequently cutting prices and demoralizing the industry in which they are engaged.

"There were over 22,000 business failures in the United States last year; more than 20,000 of them were small concerns. We all know that a large percentage of business is run at loose ends, haphazard and without the proprietors really knowing at any time how they stand or whether they are making a profit or a loss."

Buggy Business Flourishing

Reports from manufacturers and dealers respecting the pressing demand for buggies and the prospects for future business vary quite a little according to the localities from which we receive them. This statement came from an official of the Carriage Builders' National Association. In some Central and Western states reports are of a very cheering character, not only as regards the amount of business already transacted, but also in reference to the immediate outlook.

A great many dealers state that their business has far exceeded their expectations, and that numbers of second orders have been necessitated by the clearing up of their first lots. In other cases dealers tell us that their trade so far this year has been about normal—no variation being noticeable, one way or the other.

As a matter of fact, there are undoubted signs of a considerable improvement in the horse-drawn vehicle business, and the preponderance of favorable reports over those of the opposite character is easily five to one.

Demand for Shafts and Poles

"The demand for shafts and poles for horse-drawn vehicles has not been materially affected in the past five years," says an Ohio member of the Carriage Builders' National Association, who has exceptional opportunities for gathering information on the subject.

"The enormous increase of gasoline cars for both pleasure and commercial purposes, remarkable enough, has not caused a big slump in the sale of shafts and poles.

"This unusual fact is attributed to the great increase of population in the United States during the past five years. This increase has been able not only to absorb the increase in manufacture of automobiles, for both pleasure and commerce, but to take care of the old trade in horse-drawn vehicles as well.

"Very few of the big manufacturers of buggies and carriages make their own shafts and poles, because they can be more cheaply bought of a factory making them exclusively than made as a side line in the buggy factory.

"I know of specific instances where the farmer is going back from the automobile with its expensive upkeep to the old buggy or carriage. The trend of the farmers, as indicated by examples he can personally cite, seems to be toward the horse and buggy," said the same authority.

"The farmer, perhaps, at first does not realize the large expense of keeping an automobile in repair, although the initial cost may seem tempting. It is my opinion that in the future more buggies and carriages will be bought by the man on the farm. Especially will this be true, now that the price of gasoline has climbed so high, while the farmer can raise all the horse feed he requires on his own premises and at the minimum of cost."

Carriage Builders to Meet in Cincinnati

The forty-fourth annual convention of the Carriage Builders' National Association will be held in Cincinnati, Ohio, during the last week in September. Nearly a thousand persons from every state east of the Mississippi, several western states and from Canada, are expected to be in attendance. The proceedings will interest every manufacturer of buggies and carriages, whether they attend the convention or remain at home.

The Carriage Builders' National Association was organized in 1872 and is one of the oldest of American trade bodies. The carriage factories represented by the membership (wagon factories not included) produce nearly all the buggies and light carriages made and sold in this country. A considerable proportion of their work enters foreign trade and they have made American buggies known around the world. Even the jinrickshas of Japan, China and India are built largely in this country.

American vehicle manufacturers and dealers are commencing to realize that the horse-drawn vehicle industry has not been affected by the war, crops and politics in any greater degree than other staple lines of business, such as food, clothing, etc. They know that on January 1, 1916, the horse population of this country was larger than ever, notwithstanding the many shipments of horses to European purchasers.

This would indicate that there is room for both the horse and the automobile in the general scheme of life.

A Square Deal for the Horse

The European war and the automobile have played havoc with the horse, according to the horsemen who assembled recently at the Hotel McAlpin, New York City, to discuss ways and means for their protection in the future. The occasion was the meeting of the executive committee of the New York State Association of Horsemen.

The sense of the gathering was that the horse has as much right to the highways as the speeding automobile, and the organization is going to do all in its power to interest children, farmers and business men throughout New York State in the conservation of the horse.

William D. Hunt, of Brookline, Mass., treasurer of the Massachusetts Protective Association for Horses, pointed out that "the value of horses in this country is still three times greater than that of automobiles."

"If all horses died today," said Mr. Hunt, "we would all starve to death, principally because we depend on the horse for what we wear and what we eat. Horses are no longer considered when a group of men get together to project the building of a new road. Nowadays, when a horse slips on the wet asphalt road, officials simply laugh at him. In Massachusetts we are determined to give the horse a square deal."

A Strange Use for Omnibuses

At the recent annual meeting of the Prudential Assurance Co., London, Eng., it was revealed that the American securities of the company which were placed at the disposal of the government were sent to the Bank of England by means of motor omnibus. The number of bonds exceeded 44,000 and were valued at over £8,750,000. This huge collection of securities made up six omnibus loads.

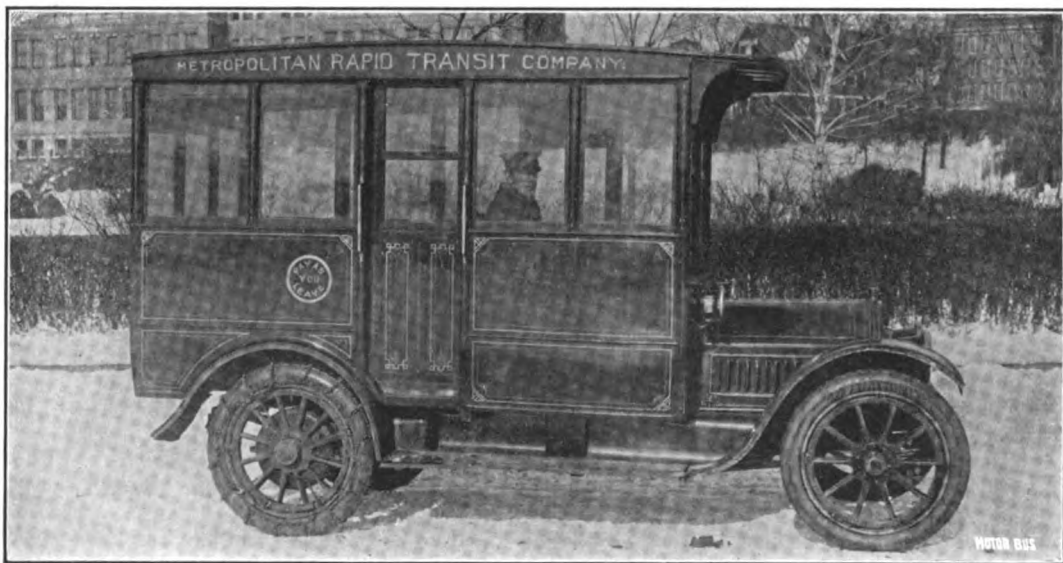
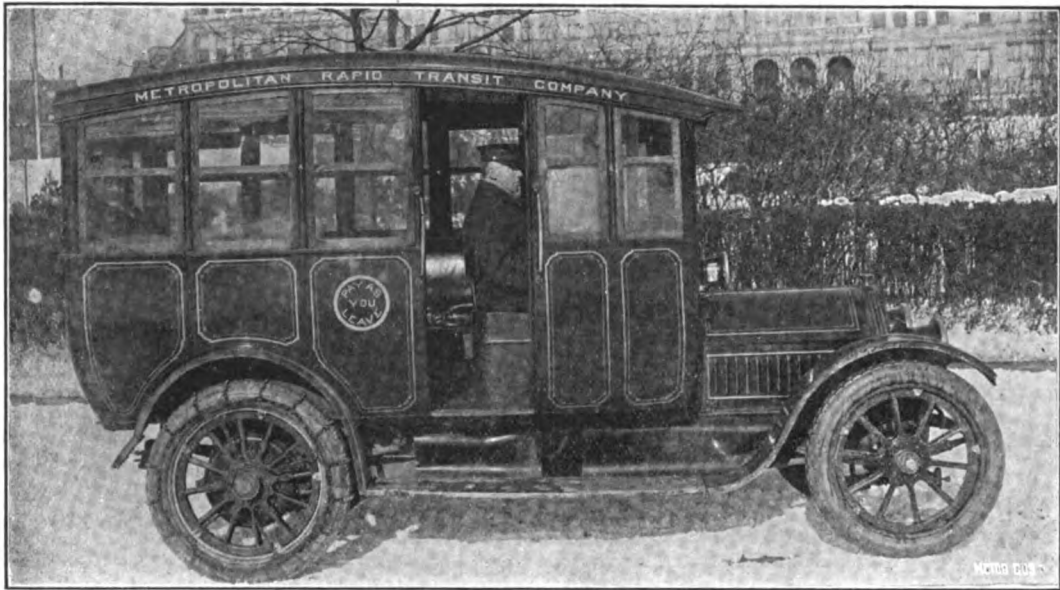

TYPES OF MOTOR BUSES IN USE IN PROVIDENCE, R. I.

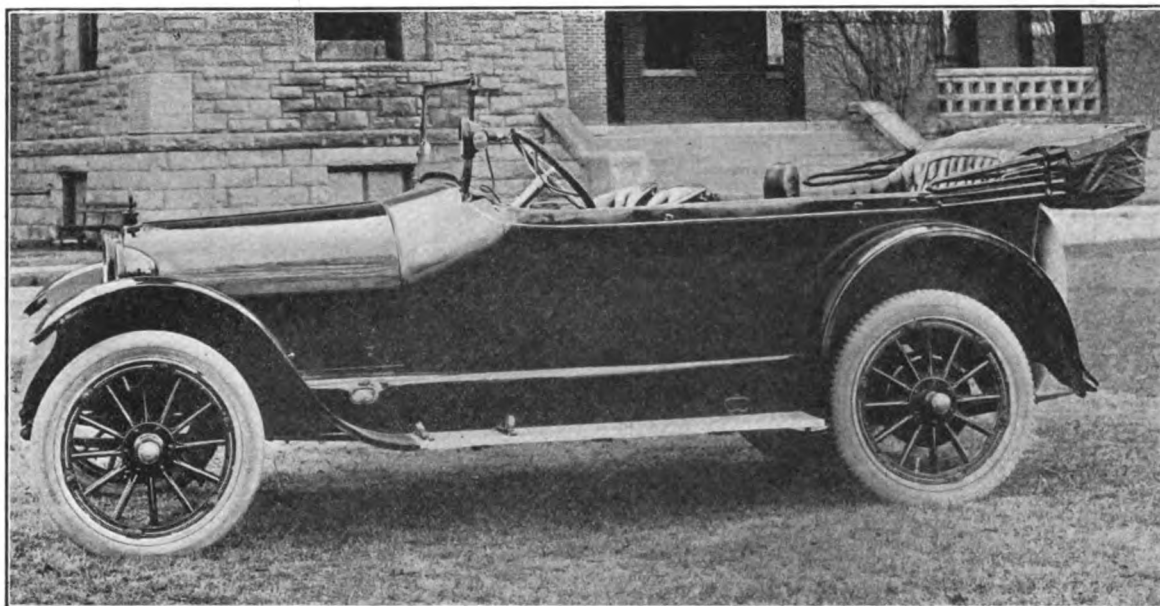

ANDERSON SIX-40-SIX TOURING CAR
Built by Anderson Motor Co., Rock Hill, S. C.
See description on opposite page

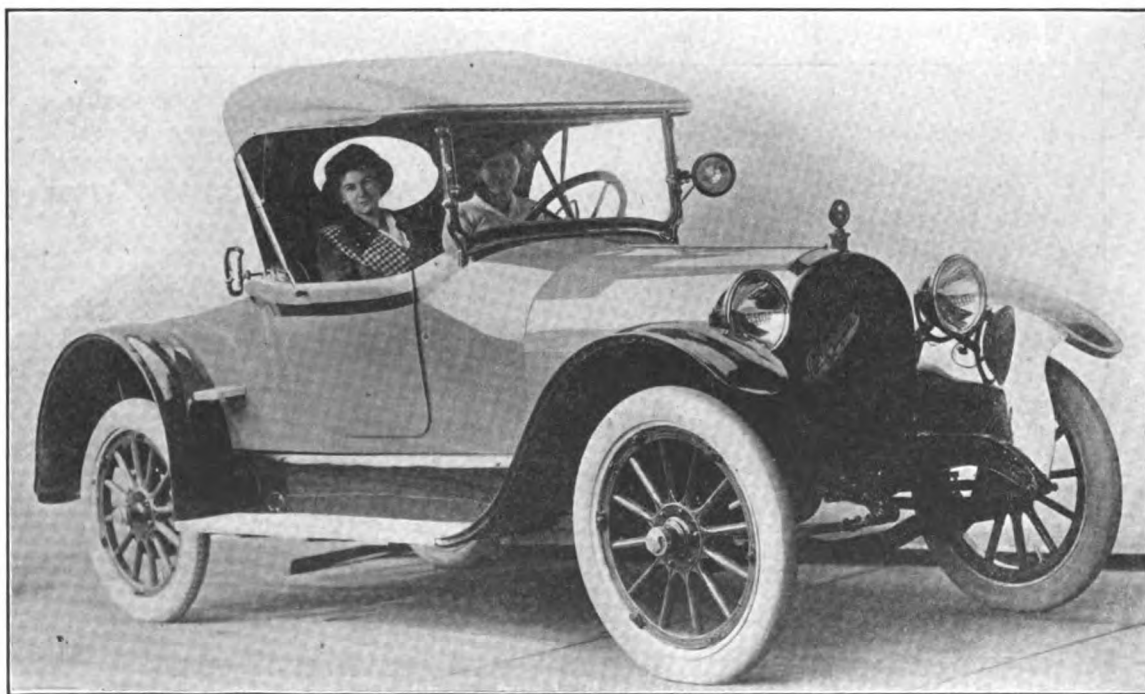

ANDERSON SIX-40-FOUR ROADSTER
Built by Anderson Motor Co., Rock Hill, S. C.
See description on opposite page

A Southern Made Car

The announcement of the Anderson six-40-six touring car, and Anderson six-40-four roadster by the Anderson Motor Co., of Rock Hill, S. C., was received with a great deal of rejoicing by motor car dealers and consumers in the south.

The Anderson Motor Co. is owned and controlled by the stockholders of the Rock Hill Buggy Co., which company is known throughout the south as builders of the famous Rock Hill buggies and wagons.

For 18 months or two years the Anderson Motor Co. had been working and preparing to build automobiles, and so the announcement did not come as a total surprise.

The engineering department was instructed by President J. G. Anderson to produce a light six car to be without comparison as to quality of material, workmanship, finish, trimming, upholstery, equipment, etc., etc. The result is the Anderson six-40-six which is listed at \$1,250 f. o. b. Rock Hill, S. C.

The Anderson car, which is the only one built in the south, and we mean when we say built in the south that

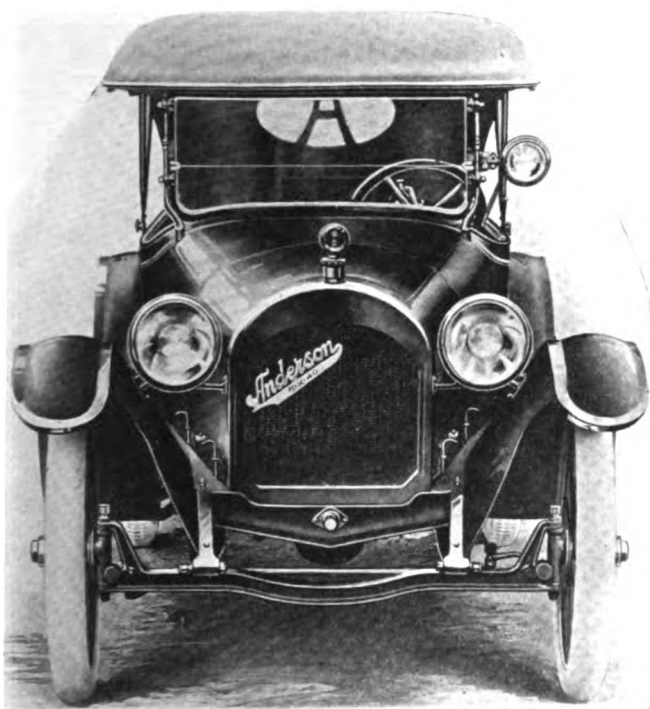

Front View of Anderson Car

the Anderson Motor Co. builds more of this car than 90 per cent of the automobile manufacturers. The company builds its own bodies, wood work and steel work; does all upholstery and finishing, builds its tops and fenders, and does all trimming. In other words, the company has utilized the large and complete plant of the Rock Hill Buggy Co. for the building of this southern automobile. These facts, along with low cost of labor and material, low freight rates to the ready markets of the south, has enabled the company to produce a car at such a low price that already the entire output of the factory has been sold, and plans are under way to increase the capacity for the present year.

The unusual complete equipment of this car includes a power tire pump, searchlight and trouble light, cigar lighter, motor meter, heater in tonneau. The complete

mud guards are very noticeable and serviceable on the car. The front seats are divided. All upholstery is done in genuine leather of the best grade.

The car is equipped with a Continental high speed six-cylinder 40 h.p. motor. The transmission is of the selective type, three speeds forward and one reverse. The wheel base is 120 inches. The frame is V shape, which eliminates several cross members and reduces the weight of the car, and also allows a small radius for turning.

The photograph with building in background gives a good side view of the car with top down, showing sixth seat which folds and can be removed by lifting out. This view also shows the distinctive lines of the car.

The color of the standard touring car is dark Brewster green; body, fenders, etc., black, with a red pen stripe around body.

The Anderson six-40-four roadster has created quite a sensation in the south because of its unusual, yet dignified appearance. The color of the roadster is: body Khaki gray and fenders dark brown. This makes a mighty beautiful car. This roadster has the same equipment as the touring car and the price is the same. There is a folding seat in the rear of the roadster with a capacity of two or three persons without lack of room.

The Domestic Dyestuff Industry

An idea of American progress in the manufacture of dyestuffs may be had from a recent report by Dr. Norton and issued by the Bureau of Foreign and Domestic Commerce. According to this report American dye works are now turning out coal-tar colors at the rate of 15,000 tons annually, and a report on the present dyestuff situation just issued by the Bureau of Foreign and Domestic commerce calls attention to the importance of the fact that these colors are being manufactured wholly from American raw material. Before the war started we manufactured only 3,300 tons of coal-tar colors, made mostly from imported intermediates. The report points out, however, that the total imports of artificial colors before the war was something like 25,000 tons, so that the coloring industries even now are not getting their normal supplies. The necessity for continued efforts on the part of all concerned in the establishment of an American dyestuff industry is apparent.

The manufacture of coal-tar crudes in this country has assumed large proportions, states Dr. Norton, the author of the report, but owing to the great demand for such products in the manufacture of explosives the dye works have not had the supplies they needed. Nevertheless there are now 17 firms engaged in manufacturing intermediates and 12 firms are turning out the finished dyes. One of the features of the Bureau's report is an up-to-date list of the firms engaged in these lines.

It is Dr. Norton's opinion that the United States is to have a permanent dyestuff industry. The textiles and allied industries, he says, are united in the determination that the country shall not again be exposed to such a famine as it has recently experienced. The large organizations of dyestuff users have expressed a willingness to bear the burden of higher prices than prevailed before the war, if necessary. Most of the companies engaged in manufacturing coal-tar compounds are planning to continue their production along the lines already taken up and to enlarge such production or enter upon the manufacture of additional intermediates or finished dyes as circumstances warrant.

AN IMPORTANT MEETING

Meeting in Cleveland, April 25, to Standardize Lengths in Axles, Hubs and Flanges

The National Malleable Castings Co., of Cleveland, O., has inaugurated a movement looking toward the standardization of axles, hubs and flanges for buggies and wagons. Two circular letters have brought responses from over sixty interested parties who have signified their approval of the idea, and a meeting has been called for Tuesday, April 25, at 10 a. m., at the Hollenden Hotel, Cleveland, O., at which time it is hoped to settle the entire question.

Many of the manufacturers submitted lists showing what should be adopted as standard lengths. The idea promises economies in operation, carrying of stock, etc., for the whole vehicle trade, and the National Malleable Castings Co. will be pleased to have suggestions from those who have not already responded, so that they may be tabulated with the others for presentation at the meeting.

The first circular, which contained details of the proposition, is as follows:

"A movement toward standardization in the lengths of axles, hubs and flanges has developed in various quarters, and some of the wheel manufacturers have suggested that you and the other manufacturers who are addressed in this letter, be asked to contribute suggestions as to the proper or most popular length for each diameter of axle.

"In the case of a 1¼ in. axle, spindles are made 6 in., 6½ in., 7 in., 7½ in. and 8 in. long. This must require numerous expensive operations for the axle manufacturers and compels the malleable iron shops to carry innumerable expensive patterns. All parties, including the wheel builders and even the jobbers, are obliged to carry larger stocks and invest more money than will be needed if a single length can be established for each diameter.

"The wheel makers who are members of the Hickory Products Association, and many others, have agreed that if this can be done, they will confine their efforts to a single corresponding length of hub, and it seems probable that the flange manufacturers might agree to do the same for the flanges. It would then be possible for these three classes of manufacturers to refuse to produce all odd sizes, especially during such busy times as the present. In fact, present business conditions make this a propitious time to suggest such action and some of the manufacturers to whom this letter is sent have already submitted ideas as to what should be established as standards.

"While a meeting has been suggested for this purpose, it does not seem to be indispensable, and if you feel in sympathy with the movement we shall be much pleased to have your suggestions which will be tabulated along with others. If there seem to be any serious differences of opinion, the tabulated recommendations can be submitted for a further final expression of opinion either by letter or in a meeting, as desired.

"Whether or not this idea appeals to you, we believe the whole trade will appreciate any suggestions you care to offer, and if you have not already done so, we hope you will give this matter careful consideration, advising what lengths you would recommend. Very truly yours,

"The National Malleable Castings Company,
"J. H. Redhead."

Consigned Goods Are Debtor's Assets

According to a recent ruling made by Judge Maurice T. Dooling, of the United States District Court, where goods are sold to a debtor on a memorandum basis, or consignment, with the privilege of a re-sale, by such debtor, a creditor cannot reclaim the goods in the event of insolvency or bankruptcy of the debtor. In other words, that a memorandum or consignment sale actually passes the title of the goods to the debtor, where such sale is made for a re-sale purpose by debtor.

This decision is of special interest to the trunk and leather goods trade, says Trunks, Leather Goods and Umbrellas. The practice of consigning merchandise has been growing during recent years and its evil effects have been strikingly exemplified by some recent failures where considerable quantities of goods were claimed by manufacturers, to the detriment of the interests of creditors.

The primary purpose of sending goods on memorandum is to escape losses in case of insolvency, and as soon as this condition is disclosed the consignor either removes the merchandise or enters a claim for it. The unfair part of such transactions lies in the deception as to the true character of a dealer's business. If he has a good sized and attractive store with seemingly ample stock the inference is natural that he is sufficiently responsible to secure merchandise from the makers. Even if references are investigated the consignor will not always disclose the true condition. In selling to such a dealer trade connections, experiences and reputation are frequently considered as of equal, if not greater, importance than capital. With an apparently prosperous business and an absence of knowledge as to the real conditions, the maker will usually extend a reasonable line of credit. When the crash comes and there is little left in the way of assets, the creditors learn that a good portion of the stock was consigned and reclaimed, leaving only small assets for distribution. Moreover, without this deceptive condition, wholesalers would not be inclined to give credit so freely nor would it be so easy for some people to get into business at all. Now that consignors must take their chances with others in the event of bankruptcy, there will probably be less of this memorandum business done. We believe the ruling will have a deterrent influence and this will work for the advantage of the better class of trade who regard the practice as one of the most serious evils in this line.

Our Horses as Viewed Abroad

The United States is a rich field to draw upon for horses, as our army buyers have demonstrated, says the London Live Stock Journal; and the official figures show that the number of horses in that country at the beginning of last year was 21,194,000, this being a slight increase as compared with the total of the previous twelve months. There were also 4,479,000 mules. It is curious to note that the mules are worth more than the horses, the value of the former being set down roughly at a little over £23, and the latter at £22. In the state of Michigan there are on farms about 625,000 horses, and it is anticipated that this number will increase, as the breeders are progressive men. In former years horses have hardly figured in the exports of this state, but since the war there has been a run on them, and many thousands have been sent out of the country. Prices have gone up appreciably, and breeders have made a lot of money.

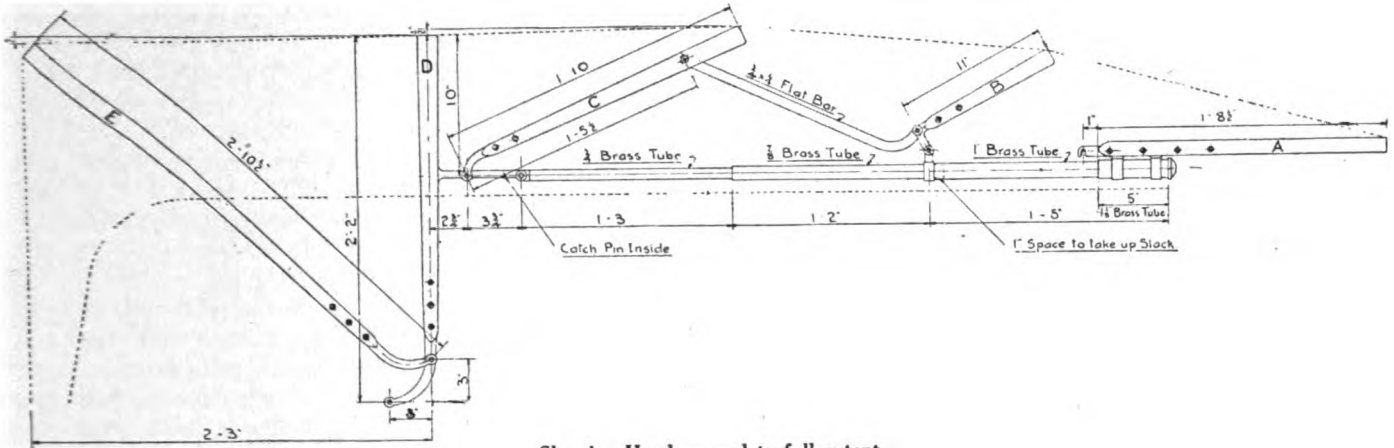

Showing Hood opened to full extent.

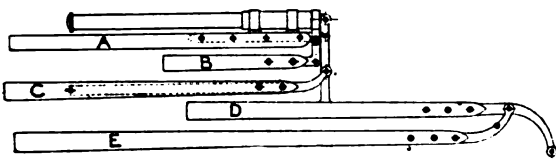

Hood folded. Outside view.

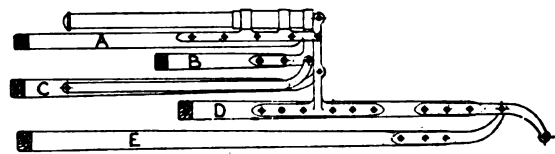

Hood folded. Inside view.

A New One Man Hood

The accompanying drawings show three views of a recently patented one-man hood, the invention of Mr. W. Egan, of 502 Spencer street, West Melbourne, Australia.

The main feature is the adoption of the telescopic principle for the framework supporting the hood in place of hinged joints. The use of tubes working one within the other enables the hood to be folded more compactly. It also prevents side motion, with its consequent chafing of the hood canvas; while the hood may be shaped to suit the taste of the builder or the style of any body. It is also simple and quick in operation, and is not expensive to build.

This hood may be raised or lowered while the car is running. To raise it the passenger in the rear seat, without moving from his position, simply hinges the peak bow over his head, then the person in the front seat draws it on to the lock on screen, which has provision made for taking up any sag in the canvas. The first named operation, raising the peak, provides a low shelter for the rear seat, if allowed to remain in that position.

The small amount of overhang at the rear of car when the hood is closed is clearly shown in the drawing, which is to scale. The extension hood hangs entirely on the canvas, thus eliminating sagging, and another good point in the tubular arrangement is that back panel and wind screen are not subject to the jarring which is a bad fault with most extension hoods. The same idea has been worked out to apply to a single hood in which one short tube or rod is used.

Mr. Egan is a motor body builder with experience in leading Melbourne shops, and he has received very encouraging reports regarding the utility of his invention.

George Fitch on "Trains"

Trains are used to transport freight and passengers, mentioned in the order of their importance, from hither to yon. At this particular minute let us consider passenger trains.

A passenger train consists of an engine, a baggage car,

a conductor, a peanut salesman, a brakeman with throat trouble and several passenger coaches. It is operated on what is known as a schedule, which is America's most popular work of fiction. The schedule shows the time at which the prospective passenger should arrive at the station in order to get a good seat near the stove in the waiting room.

Passenger trains are divided into three classes: limited, local and accommodation trains. Limited trains are very fast and only stop for crossings, semaphores, side tracks, cows on the track, hot boxes, orders and coal. They are very luxurious and are supposed to get you to your destination on time for which you pay from five thousand to ten thousands dollars extra. This explains the "limited" part. You have to ante before you get on, and there is a ten-dollar limit.

Local trains stop at all stations and elsewhere and are very careless, losing ten minutes here and thirty minutes there with the utmost unconcern, like the messenger boy. They are patronized by the plain people and are afflicted with prehistoric coaches and newsboys who prey on the passengers and sell them peanuts, figs and Elinor Glynn's latest works in a hoarse whisper at the end of the car. Local trains run from "Aoughwow to Sstreech," according to the brakeman and the next station is "Arglouuuu." If a man is stubborn about it, he can reach almost any town in the country on a local train. A man once traveled from New York to San Francisco on a local train, but it took so much time that he had to walk back.

Accommodation trains are composed of freight cars and a caboose, in which passengers ride on the floor and the ceiling alternately. Accommodation trains are so named because they frequently wait on the side track while a farmer's hogs get fat enough for him to ship with profit. Waiting for an accommodation train and waiting for Halley's comet are two operations requiring more misguided patience than anything else on record.

There is enough unoccupied land in the city of New York to give each family a plot 50 feet wide and 100 feet deep to build a home upon.

"Ghost Trains," Old and New

Do you ever see automobiles shipped in coal cars? No, we believe you never have. Neither did we until this year. In fact we never expected to, but in these days of freight car congestion, a condition which reaches throughout all the land, some manufacturers of automobiles, realizing the importance of getting their goods delivered, have had special cars constructed for automobile transportation. Other manufacturers have been compelled to use coal cars, fitted up temporarily for the purpose, to transport their product.

At present there are about 70,000 regular cars suitable for automobile shipment in the United States. But 70,000 automobile cars have proved entirely inadequate. At this time shipments are badly complicated through the fact that over 150,000 freight cars are lying along the Atlantic seaboard and inland as far as Buffalo, Pittsburgh, Chattanooga, Atlanta and Mobile because of lack of ships to take their cargoes to foreign ports.

Other little things, like snow storms in the West and floods in the South, have meant more unavailable cars. These conditions have given the traffic managers of automobile companies a serious problem to solve.

Automobiles on Flat Cars.

Because of inability to secure enough automobile freight cars, an automobile company of Toledo, Ohio, has hit upon the expedient of shipping a part of its product in flat cars and gondolas in order that the daily output be kept moving as fast as manufactured. Of course, all the automobiles shipped on these open cars are tightly covered with tarpaulins.

The sight of a number of automobiles on flat cars, securely lashed to the car flooring and covered with tarpaulins, is daily becoming more common in railroad yards and is good evidence of the endeavor of at least one company to fill with all possible dispatch the orders that have been coming in for these popular cars.

Amesbury "Ghost Trains"

However, there is "nothing new under the sun" and there is nothing brand new or modern in the idea of shipping vehicles on flat cars under the protection of white tarpaulins. Years and years ago, or, in other words, between a quarter and a half century ago, it was the usual custom to ship carriages in this manner. An old newspaper gives us an account of the origin and growth of the carriage industry in Amesbury, Mass. This paper shows one of the "ghost trains," as they were termed, which were made up of flat cars of carriages, each carriage being encased in a tarpaulin for protection against the weather. These white shrouds gave the vehicles a weird appearance and led to the appellation "ghost trains." For many years this was the mode of distributing finished carriages to the trade throughout the country.

Start of the Buggy Industry.

Carriages were first built in Amesbury, Mass., as early as the year 1800. The work was very likely largely on the lines of the "one-horse shay," which was the most popular vehicle at that time. About 1840, at least one firm in Amesbury was doing carriage work. In 1853, J. R. Huntington, then a young man of 21 years, went to Amesbury and there shaped his ideas into wood, iron, leather and the various articles that went into the vehicles he built. He knew that the vehicles then in use were sold at a

price above the purchasing power of the masses, so he built his work with the view of making it the equal of any in finish and could be sold at about one-half the average prices of the time.

He had struck the key-note and his success was phenomenal. Modern carriage building on the factory principle dates from Mr. Huntington's start in Amesbury. It was in Amesbury that the high standard of carriage construction, which united cheapness and beauty, were worked out during the early years of the last half of the nineteenth century. It was in Amesbury that the "ghost train" had its origin. If the bright idea of shipping automobiles under tarpaulin covers has returned, we must look for the original shipments of this kind in the "ghost trains" which used to pass through the countrysides of Massachusetts every night like fast-flying processions of spirits from another world.

National Shoe and Leather Market Fair

The National Shoe and Leather Market Fair to be held in Mechanics Building, Boston, Mass., July 12 to 19, 1916, will be an exposition of finished products, materials, machinery, and supplies representing that branch of American industry. Reports received from Commercial Agent W. A. Graham Clark, in charge of the Boston district office of the Bureau of Foreign and Domestic Commerce, show that special efforts have been made to interest foreign buyers and shoe manufacturers, and others identified with allied branches of the shoe and leather trades abroad.

Meetings of shoe and leather buyers are to be held at the fair building, and the New England Shoe and Leather Association will have proceedings and will entertain visitors. Co-operation has been extended by the National Shoe Retailers' Association, the National Association of Shoe Factory Superintendents and Foremen, and various other trade organizations. Western manufacturers will show their products. An interesting exhibit will be a full equipment of shoemaking machinery in operation.

Special entertainments and excursions to various points are to be provided. The effort to draw a large attendance of foreign buyers is a feature of the preliminary arrangements.

Why the Horse's Collar Was Worn

Mr. Freeman was a wheelwright, who staked his reputation upon, above all else, his tire setting. Yet he did not always please. One day an angry customer complained that tires recently set kept slipping off the wheels. He had frequently to stop to drive them on. Freeman would not admit that his tiring was at fault. He said: "Your axle is either badly set or is not square across the body. Let me see your horse's collar." The mystified customer thought he was daft, but led the way to the horse and cart. "There," said Freeman, pointing to a place on the "pipe" of the collar, through which the straw stuffing could be seen, "that's it. That's caused by the shaft wearing against the collar through the tendency of the cart to deviate from the direction taken by the horse."

An examination of the cart showed he was right. The wheels were not parallel to the side of the body. When the fault was rectified there was neither trouble with the tires or undue wear on the horse's collar.—Australasian Coach Builder and Wheelwright.

Shall the Differential be Abandoned?

The necessity for a differential to allow a corner to be turned without slipping either of the driving wheels has only recently been questioned with respect to automobiles, although street cars and locomotives have always been made with plain, solid driving axles. Today it seems possible that we have for years been laboring under a delusion, in so far that experiments are showing vehicles without differentials to possess certain distinct advantages.

In 1913 automobile engineers were much interested by the elimination of the differential from the Sunbeam racing cars, and in the races of that year in Europe these machines showed a good tire economy, while the drivers commented upon the remarkably steady steering at high speeds. In 1914 the Sunbeam company abandoned the scheme, giving as the reason the fact that a blowout at high speed on a rear wheel made the steering hard, was actually dangerous in fact.

Meanwhile several small cars appeared on the European market without differentials, notably the Mathis designed partly by E. Bugatti, and the baby Charron. These little cars proved just about the same from the viewpoint of tire wear as though they had the differential, they exhibited slightly less tendency to skid when driving, and much less when braking, while they were exceptionally easy to steer at speeds of 50 m.p.h. Moreover, a blowout did not seem to disturb the steering within the speed range of which the little cars were capable. The most prominent disadvantages were that cars had to be taken to use identical tires on both rear wheels, since if one were a trifle larger than the other the tread soon became rough and chafed on the larger casing; and that the cars were difficult to push by hand except in a straight direction. With little cars usually kept in cramped quarters this was a real disadvantage to many owners.

At the outbreak of war this no-differential experiment in the light car world was being watched with great interest, but, of course, nothing has been done since August, 1914.

Truck Tests Made in America

During the past year in America experiments have been made beginning at the other end of the scale, on a series of large motor trucks instead of on light cars. Also there are on the market several substitutes for the differential gear designed to limit the extreme freedom of action which is the differential's worst fault. The most instructive of the tests are those now being made by the Fifth Avenue Coach Co. on several of the busses which are running on routes in New York City, these tests having been commenced at the instigation of A. M. Laycock, chief engineer of the Sheldon Axle & Spring Co.

Last fall the differential gear was taken out of one of the busses, the two halves of the casing being locked together, and care was taken to preserve this as a strict secret, none of the drivers being informed.

Concerning the performance of the bus the chief engineer of the company, G. A. Green, reports two things

of special importance. The first is that the bus was not troubled in any way by the winter snows, though these caused considerable delay and difficulty with many others, and the second is that the wear on the tires appears to be less than normal. Since the differential was removed the distance run is well over 31,000 miles and the original rear tires lasted 15,495 and 16,000 miles respectively. At the time of their removal they were still a little over half an inch larger in diameter than the limit, there being $1\frac{1}{4}$ in. of rubber left instead of $\frac{7}{8}$ in. This mileage compares well with the average for the busses, as that is about 11,000 miles, but Mr. Green points out that the results are inconclusive because such large variations are noticed in tire durability. He considers it will be necessary to wear out six or seven sets of tires before the tire wear can be estimated properly. It is, however, some small confirmation of the durability shown in the first set, to learn that the second pair of tires are still in operation and are approaching the mileage given by the first pair.

As regards liability to skid this seems to be about the

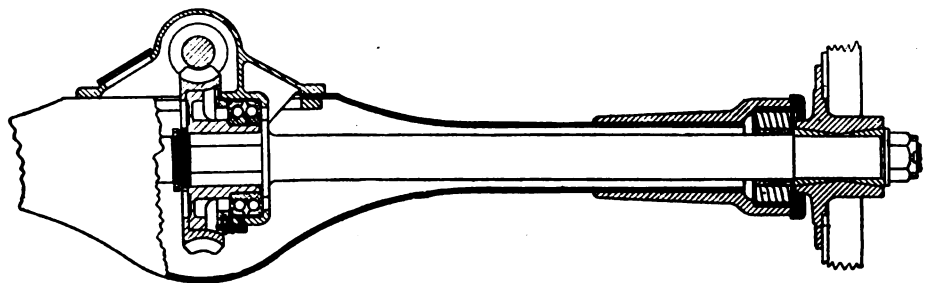

Sheldon worm driven axle with single solid drive shaft replacing the original differential

same, except when braking, when it is less, and the only comment the driver had to make of an adverse nature was that the bus seems sluggish on making sharp turns, requiring more throttle opening than usual. Several other busses are now being converted and will be run throughout the present year, Mr. Green hoping to decide the matter completely by next winter.

The most attractive feature of a differentialless axle from the engineer's viewpoint is the opportunity it affords for saving weight. In the experiments made thus far, ordinary axles have been used with the differentials filled with lead, or with the drive shafts taken out and a single shaft, solid from end to end, inserted in their place. If designing an axle to operate without a differential, however, it would be possible to use a shaft strong enough to carry the weight as well as taking the drive, which would mean that the casing for the worm gear would only need to be strong enough to support the driving stresses and would have no weight-carrying function.

In addition to the bus experiments, the Sheldon company has sent out a number of axles without differentials to different parts of the country, and is getting most encouraging reports from the Middle West and parts where trucks are used largely on sand roads. In loose gravel the absence of the differential may easily make all the difference between ability to proceed and complete stalling. The results of these experiments are also being watched with care, so that much valuable data should be available in a few months.

At first thought the idea of removing the differential

sounds absurd, and the first anticipation is that the chafing action on the tires would be very bad, but when the matter is examined in detail the question of tire wear is easily explained.

Slip on Sharpest Turn

For example: The sharpest turn made by an automobile in service is of about 20 ft. radius, and very few turns are made as sharp as this, the majority of deviations from the straight line being of 100 ft. or more in radius. Taking the extreme case, imagine a vehicle with 34-in. tires making a turn at 20 ft. radius. Turning through a right angle the inner wheel will be 20 ft. from the center of turning and the outer wheel 24 ft. 8 in., so the distance traveled by the inner wheel in making the turn will be 15.7 ft. and that covered by the outer wheel 19.3 ft. Now the 34-in. wheel covering these distances will, if rolling freely, make 1.76 and 2.16 revolutions, the difference being 0.4 revolution. It is still a moot point as to which wheel does most of the slipping, under these circumstances, but it is safe to assume that it will be mainly the inner wheel. This slipping, of course, causes some wear.

Action When Braking

Turning to the other case, where a differential is fitted, it is not possible to calculate the slip, but every time a rear wheel passes over a bump and so leaves the road for an instant it is slightly accelerated and is slowed down again by friction when it returns to the road. The amount of acceleration is very small, but what makes the big difference is that the slipping caused in this way is going on during the whole time the vehicle is running, whether straight or on turns, whereas the solid axle causes slipping on turns only and prevents the acceleration effect. If one wheel is off the ground, the other being in contact with it maintains the speed of revolution of both wheels constant.

The reason that the solid axle reduces the tendency to skid when braking is that either rear wheel must continue revolving if the other is turning. If one wheel rests on a wet patch and the other is on dry road, that on the wet can be made to lock by a light application of the brake. Directly a wheel ceases to revolve and begins to slide it is useless for controlling the direction of the vehicle, it merely takes the path along the road which offers the least resistance, and variations in the condition of the surface cause the locked wheel to try to follow a tortuous path. If the other wheel is locked also the rear end of the vehicle will have no sense of direction, whether the axle has a differential or whether it has not. When one wheel is locked and the other, being on dry road, is not locked, then the latter is liable to be pulled out of its path by the gyrations of the former, but when both turn together, at the same speed, as they must do with the solid axle, then both keep their sense of direction and maintain the straight course. It is easy to see why the solid axle enables snow or sand to be taken without trouble, and the braking question is merely a reversal of the same argument.

The ideal, of course, all other things being equal, is to have a differential for making sharp turns and not to have one for 99 per cent of normal running. Thus there is a great deal to be said for a modified mechanism which will strike a mean between the two extremes. Whether the solid axle, or a modified differential comes to be accepted practice, or whether the old differential will emerge from

the time of trial in unaltered form is a matter for speculation, but it appears that 1916 will stand out in automobile engineering as the year when the differential question was settled.—A. Ludlow Clayton, in *Automobile*.

A Cement for Leather

To prepare a cement suitable for leather belts or for fastening paper covering to pulleys, get the best cabinet maker's glue, in a quantity suitable to your requirements. A large quantity can be prepared if desired, for it will keep for some time after being mixed, if not permitted to dry out. Break the glue into pieces and put in a dish, with water just sufficient to cover it, and let stand 12 to 14 hours, or until all of the water has been soaked up. Then melt the glue in a water or steam bath and add strong vinegar to thin it. It should then be evaporated until it will appear quite stringy from the stick or spoon used to stir it while hot.

A leather belt should be roughed or furred with sandpaper or a coarse file, which will make the joint stronger than if the leather were left smooth. If the leather is warmed before applying the glue, a better joint can be made. The laps should be scraped down to a thin edge and their length should be equal to the width of the belt. In making the joint lay the belt on a board so that the parts come even, then fasten with a couple of nails through the leather a foot or more from the joint on each side, so that when one piece is raised from the other to apply the glue, it will fall back into proper position. Apply the glue warm and pound the joint all over with a hammer and a block laid on the leather. A few tacks driven through the joint will assist in holding it together properly until the cement has set.

The same preparation can be used for fastening paper, cloth or split leather to a pulley to increase the driving power of the belt. If of iron, the pulley should be well cleaned by scraping and then washed with strong vinegar or a weak solution of sulphuric acid in water. Wipe dry, and apply the paper, which has previously been covered with the hot glue. Two or three thicknesses of heavy straw paper will be found sufficient, and each layer should be firmly glued on. As soon as the first layer is applied and before the glue has had a chance to cool, roll or hammer the paper to bring it in contact with the pulley. Each layer should be treated in the same way. A belt should remain undisturbed for about five hours after the joint is made, before an attempt is made to use it. Three or four hours will be sufficient for the paper covering on the pulley.—Power.

Dock Charges on Imported Cars

Under the directions of the Port and Transit Executive Committee, the Port of London authority have given notice that the following charges, in addition to the ordinary tariff rates, on motor cars now placed, or to be hereafter placed, on the quays at any of their docks, of which delivery is not taken within twenty-four hours of being ready, will be imposed as from March 1st: For each day or part of a day 2s. per 40 cu. ft. with a minimum of £1 per car per day for the first seven days, double that amount for the next 14 days, and 6s. per 40 cu. ft. with a minimum of £3 per car per day after 21 days. These charges will not be leviable until after 72 hours from the time of the report of the vessel.

"Happiness Supreme"

The favorable impression created in the harness and vehicle trades by the appearance of Poster No. 1 in the C. B. N. A. series will be strengthened by an inspection of the second poster design, which is now ready. Poster No. 2 is reproduced in miniature on this page, but as it is represented in black and white it does not, of course, do justice to the four bright colors of the poster itself.

The first design issued by the vehicle trade press committee of the Carriage Builders' National Association was entitled "The Pleasure of the Road." The phrase was exemplified by the artist's drawing of a young man and his best girl enjoying the delights of a buggy ride through a country lane.

The second poster, now ready, brings the "pleasure of the road" to the entire family, and shows an up-to-date canopy top surrey, drawn by two fine horses. Father,

son, and daughter occupy the comfortable, roomy seats, with "dad" at the reins. The surrey is, of course, equipped with rubber tires, and the harness is "spick and span."

As the happy family rolls smoothly away from the homestead the inseparable dog runs alongside, barking his good-bye. Perhaps he will follow his good friends as far as his legs can carry him, but after a mile or two he will give up the unequal chase, and, standing in the middle of the road, will watch the vehicle until it disappears around the next bend. His tail will wag, and how genuine will be his welcome when, some hours later, he meets the returning "joy riders" at the end of the long lane! And so it goes. The automobile will have its advocates, the movies will gather in the nickels, and the bright lights will shine along Broadway, but somewhere out on the road somebody will be gliding along in a cozy buggy or a roomy surrey. Somewhere, two somebodies will be exchanging confidences while the reins hang over the dash and the good horse finds his own way home. Somewhere, congenial friends and kinsfolk will be finding in the surrey what all the world seeks but does not always find: "Happiness supreme."

Poster No. 2 is 15 x 29 inches in size, and is designed to give favorable publicity to the horse and all his accessories, such as pleasure vehicles, harness, horse goods, and other equipment. Space is left at the bottom for the insertion of the dealer's or the manufacturer's name and address.

It is desired that every one interested in the sale of carriages and horse equipment shall have the opportunity to inspect this new poster. They will be furnished to manufacturers and dealers at low prices, as the C. B. N. A. is bearing the expense of the original paintings and plates from which the posters are printed. Manufacturers can furnish them to their dealers or dealers may buy them and have their own names printed on the posters. A few hundreds put up in public places in the dealer's territory will turn the attention of passersby to the sterling worth of the horse-drawn vehicle.

A sample, with the special low prices quoted, will be sent to manufacturers and dealers who make the request

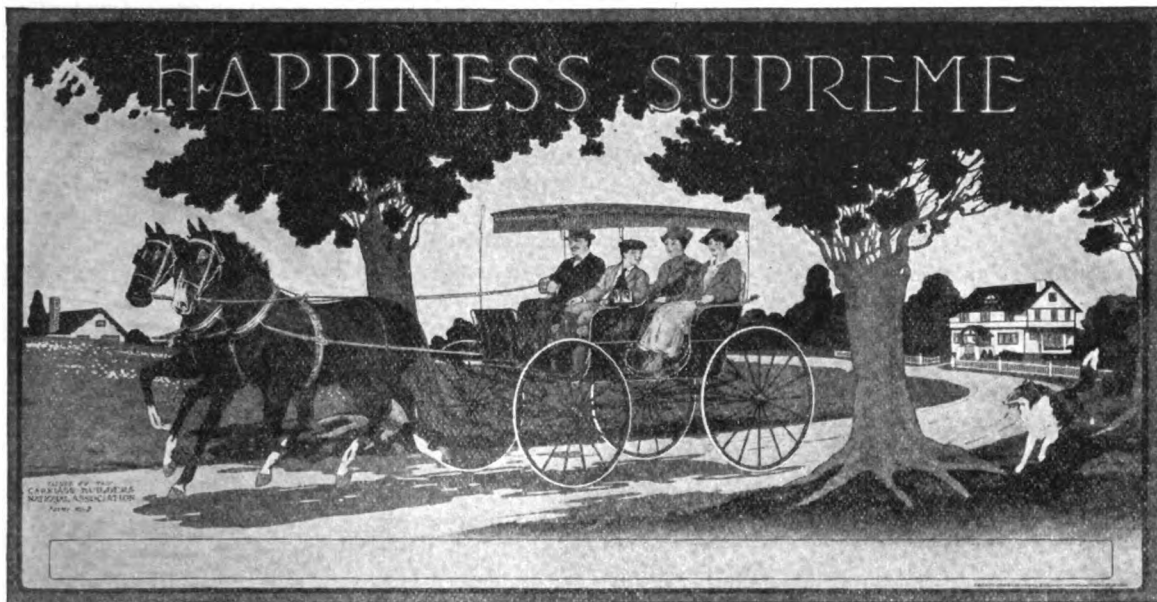

on their business stationery, addressed to the Vehicle Trade Press Committee, A. M. Ware, chairman, 1010 Arch street, Philadelphia.

To Push Sales in Russia

A company is being formed in Detroit, Mich., whose purpose is to embark upon a moderate capital of trade intercourse with Russia. The organization will be known as the International Manufacturing Sales Co., with offices in Chicago. It will represent a capital of \$250,000,000 and will distribute in Russia gas engines, farm tractors, automobiles, motor trucks, motorcycles, etc. The company will have its head sales office in Moscow and will maintain a big selling organization.

Troy Trailers for U. S. Army

The United States government bought eleven 2½-ton Troy, N. Y., trailers for use in the punitive expedition against Villa in Mexico on March 21. These trailers were shipped by a special train which made passenger train time on the trip to El Paso, Tex. There was not time enough to give the finishing touches in the factory and a squad of painters was sent along to give the trailers the second coat and striping on the run.

The Cash Value of Friends

Once we talked with a young, capable, ambitious man who prided himself on his independence. He had what might be termed aggressive independence—the sort that adopts the motto: "So live that you can look any man in the face and tell him to go to," etc.

This motto is a trifle stagey and listens just like moving pictures of ten, twenty, thirty melodramas. It is out of joint with these times when efficiency comes through co-operation and mutual helpfulness.

We asked him: "Which would you prefer, a thousand dollars and no friends, or a thousand friends and no dollars?" "Of course," he admitted, "I would prefer the thousand friends, as through them I could soon get the dollars also."

We then pointed out that independence is entirely consistent with a conciliatory attitude. Disregarding the ethical, altruistical kind of friendship and considering only friendship based on mutuality, every man with whom we come in contact commercially represents a possible asset—a source of help in achieving success. Why should not a poor but ambitious young man build up a fortune in helpful friends? Why sidestep this man because of his religion; that one because of politics, and another because he wears his hair long or his trousers short? Such action is utterly foolish in a business sense and in every other way.

The merchant must welcome every prospective customer to his store, and try to gain his confidence and, in an impersonal way, his friendship. It is just as necessary for a traveling man or an office or mill employe to follow the same method in merchandising himself.

Then, too, the concern he works for wants friends, and he is part of the concern. It is up to him to be cordial and sincere and helpful in order to get back cordiality and sincerity and helpfulness from those with whom he comes in contact.

Making friends is the most pleasant and profitable occupation in the world. Nothing lubricates the wheels of life like friendliness. The art of making friends is easy to acquire; just be one yourself.

An ancient saw ran: "If you can't conquer your enemy, make him your friend." A better motto would be: "I will make every man my friend by being a friend to him."

Most men who play games like to play for a stake, be it money, trophies or chips. They say it makes the game more interesting. All right, let's value friends at \$10 each per year. Let's also assume that to get the \$10 value we have to be a \$10 per year friend to him or some one else. Thus if in a year we gain 100 friends our personal assets have increased \$1,000. But this also implies that we have passed out \$1,000 worth of friendship during the year.

In this beautiful game everybody wins because all the wealth is created. Make no mistake in thinking that wealth is fictitious; it is the liveliest, surest asset in the world. Sooner or later it can be translated into actual cash or commercial credit through promotion, opportunities and practical help in achieving success.

The conversation first mentioned took place late last fall. The day after New Year's the young man said: "My New Year resolve was to make one friend a day if possible." We credited our friendship account with \$10. We hope he did the same. Surely our advice was worth \$10 to him.—Du Pont Magazine.

After the War

Commercial Attache A. H. Baldwin, London, England, in Commerce Reports says manufacturers in Europe already look forward to the immediate and urgent need for a large amount of reconstruction work that will arise at the close of the present conflict in those regions where war's ruthlessness has laid low towns and industrial plants and destroyed bridges, railroads, and equipment of every kind. It is certain that the desire will be to rehabilitate devastated areas as soon as possible, and many British, French, and Belgian firms are already making careful plans for the future, organizing their forces and gathering information about probable needs, in order that no time may be lost in taking advantage of the trade opportunities that are sure to exist then.

The extent of these opportunities will be so great that European manufacturers will be unable to take care of them all. It is therefore important that American firms should begin their preparations early and take the necessary measures to handle the trade that will be offered to the United States. Many competent observers in Europe believe that the war will end, when it does end, with great abruptness. The result will be that, practically without warning, the vast amount of industrial activity now directed to the preparation of war supplies will suddenly stop and a very embarrassing period of readjustment follow. Difficulty will almost surely be encountered in the reorganization of labor and in the change to new forms of manufacture. Hundreds of plants will be affected, and time will be required in these industries for rearrangements before the necessary work of replacing losses by war destruction can begin.

Fine Horses Attract Attention

In the driveways of our largest cities the automobile attracts no attention whatever, and those who occupy the seats often have an appearance of martyrs to their environment. The fact that they are begoggled and beswathed with unattractive attire excites more of a feeling of pity than of envy.

Those who love comfort rather than speed and the opportunity to get some idea of the outlying districts rather than to catch a dim glimpse of them as they flash past still cling to the horse.

There was a time, not so long ago, when the automobile attracted more attention than the horse. Many retail business firms used automobiles for the delivery of goods more because of the advertising value of the outfit than for any other reason. Now no more attention is paid to an automobile than to a street car.

On the other hand, a fine pair of horses or a single horse, well harnessed, well groomed and seemingly conscious of beauty and strength, attracts decided attention in the large cities.

N. A. A. J. to Meet in Hot Springs

The National Association of Automobile Accessory Jobbers will hold its spring meeting at The Homestead Hotel, Hot Springs, Va., on May 9 to 12. A large attendance of members is expected as well as visitors from various parts of the country. The first two days will be devoted to meeting of the directors and various committees and the last two to general sessions. A great many subjects of general interest to the trade will be discussed.

A Century in Business

The F. H. Lawson Co., of Cincinnati, O., has just rounded out a full century in business, and to commemorate the event has issued a booklet entitled "A Century of Service." This company has grown into a position where it is now manufacturing possibly more buggy seats and automobile sheet metal parts than any other sheet metal manufacturer in the country. The history of the company, as briefly told in the booklet, makes interesting reading, and is as follows:

A Century of Service

On a spring morning in the year 1816 an Ohio River flat boat, manned by a lusty crew of daring rivermen, came to a landing at the foot of Broadway, in the pioneer town of Cincinnati, then a thriving trading community of ten thousand inhabitants.

A considerable assemblage of citizens gathered at the water's edge to witness the scenes of bustling activity that always attended the arrival of a barge from Pittsburgh, and to get the first glimpse of such new arrivals as might constitute the cabin passengers of the primitive craft.

The first passenger to disembark was a young Englishman bearing a little child in his arms. Behind him came his wife holding two other little ones by the hands.

The young Englishman lost no time in establishing his family in a comfortable house in what was then the most desirable residence section of the town and in opening a store and shop on Main Street, near the corner of Fifth Street, where the Dennison Hotel now stands. His freshly painted sign bore this inscription:

THOMAS LAWSON
Iron Monger, Brazier and Metal Worker

Thomas Lawson was a sturdy Yorkshireman who had already acquired a very comfortable independence in the old country before coming to America. Indeed it was because of his unalterable opposition to certain tax laws that bore heavily upon the thrifty trade classes of England at that time and which he held to be harsh and unjust, that he packed up his family and converted his property into negotiable form and sought the larger liberty of the New World.

Cincinnati at that time was not only an important trading town with a fast growing population, but then, as now, it was the "Gateway to the South." The young smith was therefore a welcome addition to the industrial community and his business soon assumed proportions which at that period were regarded as colossal.

The Ohio River was the great artery of trade with the Southern States and Thomas Lawson was the first western manufacturer and wholesaler in the metal trade to develop a large business with the sugar refineries in the valleys of the Ohio and Mississippi Rivers.

Fourteen years later, in 1830, Mr. Lawson took his three sons, Fenton, Robert and Thomas, Jr., into partnership and the firm became known as Thomas Lawson & Sons.

During the ensuing decade the business grew in volume and importance and it embraced, in addition to the manufacture of staple sheet metal goods, a jobbing department handling copper and tin ware, plumbing goods, tin plate and metals.

At the death of Thomas Lawson, Sr., in 1841, the sons continued the business as Fenton Lawson & Brothers, until the demise of Robert Lawson and the retirement of Thomas Lawson, Jr., when the older brother took complete control and operated under his own name, Fenton Lawson.

Fenton Lawson, the first of the name, following the example of his father, brought up his three sons with the idea of succeeding to the control of the business and at his death in 1853, George Park Lawson and Franklin Hey Lawson, grandsons of the founder, assumed control of the business where their father had laid it down. The new firm was designated as F. Lawson's Sons.

On the retirement of George P. Lawson, two years later, William G. Coffin became a partner, continuing for almost thirty years in active service until his death in 1884. During this period the firm was known as F. H. Lawson & Company.

Franklin Hey Lawson, consistent to the traditions of the family, educated his sons with the idea of continuing the business in an unbroken line of descent. In 1880 Fenton Lawson, the second of the name, was admitted to membership in the firm. His brother, William C., became a partner in 1886.

In 1894, the Company was incorporated under the laws of Ohio, as The F. H. Lawson Company and F. Rogers Lawson, a younger son, became an active member of the organization. M. F. H. Lawson remained with the corporation until his death which occurred in 1910, he having then been the head of the business for 57 consecutive years.

Fenton Lawson, great grandson of the founder, was elected to succeed his father, as President. F. Rogers Lawson became Vice-President and J. M. Eversfield assumed the duties of Secretary and Treasurer.

Comparatively few business enterprises in the United States have successfully weathered the storms of one hundred years. Still fewer are those that have remained in control of one family, from father to sons, for four generations, growing steadily in strength, in financial stability, in credit, in honored reputation and in the scope and range of their activities.

It is for this reason that we feel gratitude and pride in attaining to our centennial.

A century is a long time, measured in the years of human life. By this measure ours is an old concern. We are old in history and tradition of honorable and successful commercial activity,—old in experience,—old in friendships and associations.

But we are perennially young in energy, in progressive ideals, in the faculty of adapting ourselves to changing conditions and making the heritage of the century that lies behind us serve as the foundation of a bigger, better business which we hope will still reflect credit on the memory of Thomas Lawson after another hundred years have passed away.

We should be ungrateful indeed were we to permit this occasion to pass without giving expression to our gratitude for the loyalty of those whose patronage alone has made our career possible.

We are truly thankful and it shall be our earnest effort to maintain the quality of our goods and the integrity of our business standards on a basis that shall merit the continuance of present patronage and strengthen the bonds of mutual benefit in the future.

Photographic Good Roads Contest

A nation-wide photographic contest in the interest of the "Good Roads Everywhere" movement, with cash prizes of \$2,600 open to everybody, was announced at the National Highways Association headquarters, April 9th, Washington, D. C.

The photographs selected in the competition will be used to establish in Washington a national exhibit on the good roads problem designed primarily to promote a nationally conceived scheme of highways.

In connection with the pending legislation in Congress to have the federal government shoulder a part of the task of "good roads" construction, the National Highways Association, it is explained, desires to have adopted a plan for a system of national highways, surveyed and located by expert engineers, so that federal funds will not be spent in a hit or miss "pork barrel" fashion, but in accordance with a scientific plan as any railroad is built or as the government itself did in the case of the Panama Canal.

By means of the photographic contest it is proposed to gather a complete picture of the good and bad roads problem as it exists in every section of the country, and this the association will use in its effort to obtain scientific "non-pork" legislation from Congress.

The cash prizes of \$2,600 were subscribed by General Coleman du Pont, chairman of the Board of National Councillors, and Charles Henry Davis, president of the National Highways Association. The competition will be known as the du Pont-Davis Road Photograph Prize Contest.

The first prize, to be given for the most striking (good or bad) road photograph, will be a \$500 cash award. In all there will be 166 cash prizes awarded.

There will be 5 second prizes of \$100 each, 20 third prizes of \$25 each, 40 fourth prizes of \$15 each, and 100 fifth prizes of \$5 each, making 166 chances in all for each person entering the contest.

The competition will be kept open for eight months, closing at noon, Tuesday, November 7th. All photographs should be addressed to "Good Roads Everywhere" Photograph Contest, National Highways Association, Washington, D. C.

Draught Horse Industry Looks Promising

From time to time we hear of the approaching "horseless age." Gaynor O'Brien, secretary of the Iowa Draught Horse Breeders' Association, says there never was a time when the draught horse industry looked more promising than at present. He says there is a steady demand for horses, and that the European war has bettered conditions in America, owing to the checking of importations. After the war Europe may have to come to Iowa for horses.

Ivan Whitted, of the Iowa Department of Agriculture, says:

"The individual who discussed through the columns of certain newspapers, the passing of the draught horse knows about as much about the horse breeding industry of this country as I know about Wall Street affairs, which is exactly nothing. We have been getting periodical wails of a similar sort for a good many years, beginning about the time electricity superseded Dobbin as motive power for street cars. No person living today

will ever see a horseless age or even anything approaching it.

"Recent sales of draught bred animals indicate a mighty healthy demand if we are at liberty to judge from the prices realized, while figures paid for high class animals at private sales are even stiffer.

"At the combination sale held recently at the state fair ground the average price realized was more than double the figures of last year. Good chunks brought from \$200 to \$225 in the open market at Chicago last week, while the bigger ones, those with weight enough to put them in the real draught class, meaning from 1,700 upward, sold up to \$250. Men at the head of the numerous establishments in this part of the country that were interested in the importing business before the war in Europe without exception report a lively demand for breeding stock at the present time."

Pioneers in Technical Training

One of the most modern developments in the educational field is the effort to establish, in all our institutions of learning, courses of instruction which will tend toward "making a living," rather than simply to educate with a strictly "cultural" end in view.

As a result of the agitation carried on by individual educators and by various industrial organizations, there have been established in almost every large city courses of technical studies, usually chosen with reference to the predominant industries of the city or state in which the school happens to be located.

One of the trade organizations earliest to see the advantages of special technical training, as a means for advancing their industry, was the Carriage Builders' National Association, which established a large school for vehicle draftsmen in New York City in 1880. A committee of prominent carriage builders collected \$5,490 in that year for the purpose of starting this school, which has now been in continuous operation for thirty-five years.

During the last few years the necessity for similar schools in other cities has made itself felt, and now, in addition to the parent institution, which furnishes instruction to hundreds of resident and corresponding students, there are flourishing schools for carriage builders in Boston, Philadelphia, Detroit, Cincinnati, St. Louis and other prominent vehicle manufacturing centers.

The carriage builders can thus be shown to have been pioneers in the present movement for industrial education, just as they were pioneers in the agitation for good roads, a subject in which the entire country has now become interested.

A Bedstead Van

A van especially constructed for carrying bedsteads is of the platform type, having a boarded roof supported on iron stanchions. There is a stanchion at each corner, one in the middle in front, and one in the centre, while the middle support at the rear is a wooden pillar, which is widened at the foot in order to increase the rigidity of the whole. The bedstead ends are stood upright and the vehicle is sideloaded like a coal trolley. In addition there are curtains all round, which roll up when not required. The equipment includes a good deep tailboard at the rear and a dickey in front.—Auto and Carriage Builders' Journal.

Year's Work in Forest Service Industrial Investigations

The annual report of the office of Industrial Investigation of the Forest Service shows developments in its work of direct interest to the wood-using industries and consumers of forest products generally.

One new phase of this work is the formation of a wood waste exchange and the collection of detailed information regarding the supply of wood waste and the demand for it. This information is made available in the form of specific quotations from bona fide buyers and sellers of waste who cooperate by supplying complete information regarding the exact form, species, sizes and amounts of waste available or desired. Schedules requesting this information, were sent to a number of wood-using establishments and a list was gradually built up. It now contains the names of several hundred manufacturers. Lists of opportunities to buy or sell waste are published every three months and sent to the various cooperators. Manufacturers have cooperated heartily and reports of sales are being received regularly.

A large amount of specific information has been made available to the public regarding the location of manufacturers, buyers, sellers, importers and exporters of forest products. Detailed information has also been collected regarding the forms of raw material needed or available at various establishments and the value of various products f. o. b. mill and at the principal markets. Records of lumber prices secured in cooperation with various lumber associations from mills throughout the United States were issued quarterly. Besides the records that have been issued in former years for the important woods in the principal producing regions, quarterly records were added for spruce and hemlock in West Virginia, New York, and New England, and for cedar poles in Minnesota and chestnut poles in the East. Information as to conditions involved were obtained whenever possible. A directory of American sawmills was compiled in cooperation with the Department of Commerce, showing the kind of lumber cut by each mill, the forms and dimensions of its products, and the railroads over which the material is shipped.

In cooperation with the Bureau of Crop Estimates, statistics on the lumber production of the United States were collected and a report published covering the year 1913, which showed the production of nearly as much lumber in that year as in 1912. Steps were taken, in cooperation with the American Wood Preservers' Association, to secure for the coming year statistics on the number of poles and ties and the amount of various other kinds of forest products purchased by the principal railroad, telephone, and telegraph companies; and a report on the amount of wood preservatives used and the amount of timber treated in the United States in 1914 was published. Approximately 100 plants cooperated in supplying information regarding the amount of wood preservatives used, including practically all the establishments of importance engaged in the industry.

Data were also compiled on the veneer, box, and cooperative industries. A preliminary report on the box industry was published in cooperation with the National Association of Box Manufacturers. This report furnished information of use to the industry, and to the Interstate Commerce Commission in their investigations of shipping containers. It was also made use of by the American

Society for Testing Materials in working out standards for shipping containers.

The office has also enlarged its activities in cooperation with various other branches of the federal government. The work has been chiefly the inspection of lumber, the revision of specifications, the furnishing of information regarding prices and the suitability of various woods for particular uses, the suggestion of better methods of handling and storing lumber, and the preparation of lists of bidders on various products. At the request of the Navy Department, a study was made of the methods of handling and piling lumber at various navy yards, and a report was prepared in which recommendations were made regarding the best means of preventing deterioration. A large amount of lumber was inspected for the Navy Department at various points east of the Mississippi. Generally the object of the inspection was to determine whether the shipment was up to the grade called for in the specification; but occasionally the Forest Service was called upon for the identification of species. Specifications for grading hickory handles were prepared and were adopted by the Navy Department, the War Department, and the Panama Canal. The Panama Canal used these specifications in the purchase of a large number of handles during the year. The specifications are coming more and more into commercial use, and 11 large railway systems have adopted them in one or more of their divisions.

A field study of southern pines in the Carolinas, Georgia, Florida, Alabama, Mississippi, Louisiana, Arkansas, and Missouri was conducted to determine the quality of wood grown in the various parts of the Southeast and the quality of lumber in the typical markets in the East and Middle West. The work resulted in the collection of data of immediate practical use in connection with the preparation of more satisfactory rules for grading structural timbers.

The reports on the wood-using industries of the various states were continued, and three new reports were published—Pennsylvania, New Jersey, and Georgia. This makes a total of 33 state wood-using industry reports issued so far. Reports for Indiana and West Virginia were completed and placed in the hands of the publishers. Data on the wood-using industries of the remaining states have been collected. A final report on the wood-using industries of the United States is in preparation, in which combined data collected in the various studies will appear by species and by industries.

Many requests were received from the public for information regarding the most profitable uses of certain woods, the markets for them, the most satisfactory woods for certain uses, where they may be obtained, etc. Inquiries come from small sawmill owners, timber owners, and manufacturers of finished and semi-finished forest products. Through the wood-using industry studies the office is well equipped to give such information. A large amount of utilization data is compiled monthly, including lists of wood-using establishments and specifications for raw material, and will be used for the benefit of lumbermen, woodlot owners, and the Forest Service cooperators throughout the United States.

In connection with the general lumber industry study now being carried on by the Forest Service, the office of Industrial Investigations has studied the adaptation of grading and manufacturing to consumers' needs, particular attention being given to yellow pine and oak. Data

were compiled also on the relative values of oak logs in lumber, veneer, cooperage, and ties.

The New FitzGibbon & Crisp Plant

FitzGibbon & Crisp, Inc., in their new plant, 700 x 90 ft., situated at Calhoun, Dunham and Marion streets, on the Philadelphia & Reading Railroad, Trenton, N. J., are better equipped than ever as builders of pleasure and commercial automobile bodies.

For the purpose of a progressing system of operation, the new plant is a one-story building. A job will be started at one end of the plant and will go through the various departments to the other end, where it will be completed and ready for shipment. To promote this system, an electric crane, which runs the entire length of the main building, has been installed. By the aid of the crane a body of any size can be transported from one department to another. Another feature is the varnish dryer and ovens.

In the sheet metal and welding shops electric power hammers have been installed. In the former department the hammers are used to shape the metal bodies, while in the welding shop a high-powered sledge will be used for heavy work.

The very latest machines, each with a direct electric motor connection, have been installed in the wood shop, and an exhaust system, which carries all shavings and sawdust from the room to the boiler room has been added. These shavings are carried out via an underground route and are deposited into the fire boxes automatically. The working power at the new plant is electric, the boilers being used exclusively for the heating system.

In the blacksmith shop each forge is equipped with an electric down draught, while a ventilating fan carries out the hot air.

The main building was built absolutely fireproof. The lumber sheds, 210 feet in length, are constructed of steel. The main building is built of concrete, steel and brick. A 900-foot siding furnishes direct railroad connection.

Besides being one of the largest factories of its kind in the east, the new plant is modern and is unapproachable so far as lighting and ventilating systems are concerned. In the painting shop the air is "washed" before a body of any kind is painted, thus assuring absolute cleanliness.

The FitzGibbon & Crisp Co. started years ago in the building of carriages and wagons, with its plant on Bank street. Progressing with time, the automobile slowly pushed into the horse vehicle field, and the building of auto bodies was turned to, with the result that the new plant was made necessary by the remarkable growth of the business.

No order of high grade work will be too large for the new plant and no order will be too small, for the old factory on Bank street will be operated as usual and will take care of local and other small jobs. The same grade of work will be turned out at each plant.

Making Use of the Doors

An unusual feature in the design and construction of an ambulance which has been supplied by a Philadelphia carriage builder to the Italian army is the use of the hind doors as loading platforms for the stretchers. The back framing consists of two corner pillars and two standing pillars each side of the gangway. The doors occupy the space on each side between the corner pillar and standing pillar, which is also the space taken up by the stretchers. The central portion or gangway is closed when required by means of a revolving shutter. The doors in question are hinged at the bottom and are supported by means of knuckle joints and slides. The upper stretcher base is hinged at the front end and can be slid down at the back end so that it forms a continuous incline with the open door. The stretcher bases can be folded up against the side of the body so that sitting patients can be accommodated. There is a deep canopy over the driving seat which is utilized as locker space.

Will Make Auto Trailer

Trailers will be the new product which Victor D. Shumard will make in the plant of the Milford Mfg. Co., Milford, O., which he purchased recently. The trailer will be of light construction, having two wheels and provided with an express body with storm top. The capacity will be about 500 pounds burden and will be supplied with either solid or pneumatic tires. Mr. Shumard will also continue the manufacture of sweepers as the Milford Mfg. Co. has done.

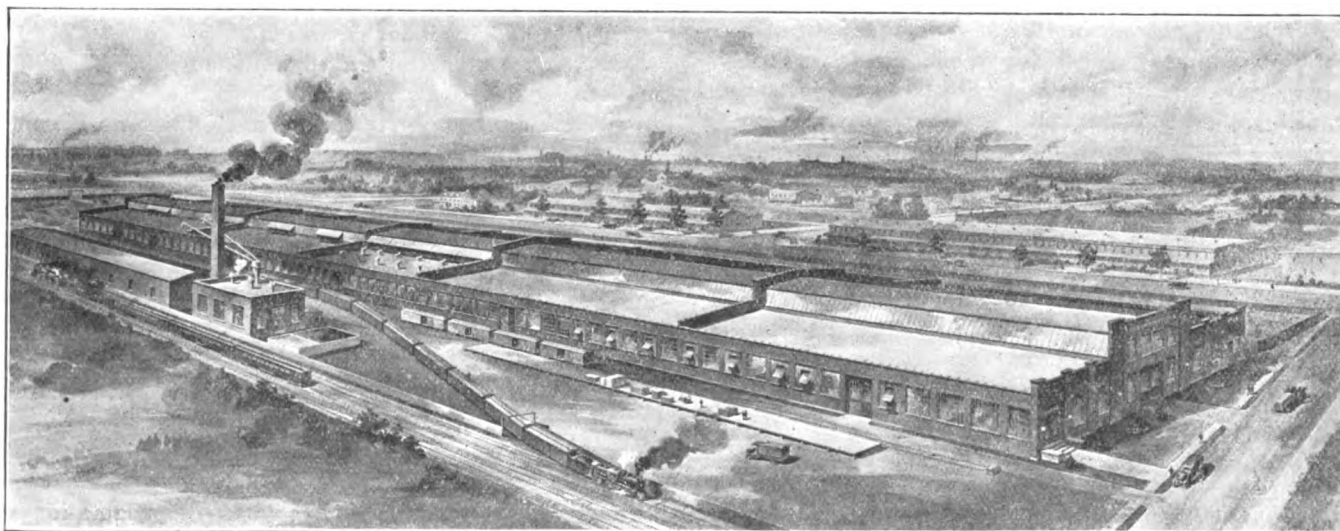

New plant of FitzGibbon & Crisp, Inc., Trenton, N. J.

Gathered Wheels

Nearly all wheels are gathered and many mechanics do not know, says Blacksmith and Wheelwright, why they should be. This rule has been known by carriage and wagon builders for 50 years that we know of, and we are certain that it was known long before that. In all cases when wooden axles laid out by our forefathers, certain rules were correctly obeyed. The first rule was plumb spoke, the second was that the under surface of wood axle was always straight across, and the third was the gather. Our forefathers knew that a wheel, no matter how much dish was given, would carry most weight when the spokes pointing to the ground were plumb.

The undersurface of axle had to be always straight across for several reasons; first, if made straight across, the wheel was equalized, and not to bear either against the shoulder or collar, or against the pin or nut. Another reason was that all wagons were greased at that time with a soft substance which melted easily and generally known as axle grease. The axle arms were loosely fitted, were open front and back, and if this undersurface would have been out of level, either way, the grease would have run out either front or back of the hub. The grease would even disappear when made perfectly horizontal, but if the wagon maker would have disregarded this rule it would have been worse.

All axles were gathered, because the wagon makers found that all axles that had run for years were all worn alike; that is, on the front surface near the pin or nut, and on the back surface, near the shoulder or collar.

There is a certain friction which acts alike on all wheels; our forefathers knew it, and most all wagon and carriage builders know it now, but many do not know the origin of that friction. The wood axles of our forefathers do not fit as do Collinge, Concords and Dalzell's; the plates, top and bottom, were fitted with heat, and, to do it evenly, the plates were heated and the wheel forced on; sometimes it burned too much, and consequently there was more play room than was needed. The more play room, the more the wheels would swag and the sooner the axle, arms and boxes would wear away, but mostly on the places above indicated. This was also the case when the wheels were out of plumb if there was too much under-set; the axle arm would wear away on the bottom of shoulder or collar, and on top of the arm near the pin or nut. If the wheels would stand the other way, the wear on the axle arm would be the opposite, that is, on bottom of arm on pin or nut and on top on shoulder or collar.

On account of the imperfect work our forefathers found on repair work the rules which should be adopted to keep the axles from unnecessary wear. They noticed also that when a wagon is loaded and is running forward or backward, the wheels will spread toward the back. This spreading is caused by friction between the tire and the ground, the weight of the vehicle and its load. The wider the tires and the greater the load, the greater the friction, and the more the spreading is increased.

Here we see that it is positively necessary that all axles should be more or less gathered. Take, for instance, a buggy carrying two persons; let the buggy stand on a floor where it can be run at least 12 feet in length. Measure the wheels both back and front across the rims at the height of the hub; if the buggy is built correctly, it will have 3/16 in. gather for rear wheels, and a little

less for front wheels, if the diameter of wheels is 34 x 46 in. Now load it with two persons who weigh about 300 lbs.; now push the buggy about 12 feet in length, so that the back wheels turn completely around their circumference; the result is that the gather is lost, the wheels measuring alike at the four points is proof that all wheels should be more or less gathered.

All axles which are connected with reaches must be gathered, and the lighter and higher the wheel the more gather they must receive, 3/16 in. each for light wheels which have from 7/8 to 1 1/2 in. spokes, its diameter being 44 x 48 in., is considered correct. The heavier wheels do not need as much gather. Wheels for coupes, coaches, landaus and omnibuses are gathered, but the axles are not gathered in setting, and it is done as follows: The springs on all such carriages are 1 1/2 in. higher front than back, the springs are fitted on top of bottom surface of axle level. The front end is turned up, and by so doing, the underset is thrown toward the front and consequently gathers the wheels just enough for what is wanted on that kind of work. The same is done with wagon platform springs in well regulated wagon shops; the springs are fitted square to the spring block, that is, the spring block has the same height front and back; then the front spring head is lifted, which throws the axle forward, gathers the wheels, and at the same time throws the wheels further toward the longer end of the springs, and by so doing equalizes better the motion of the springs.

Caney Retires from Batavia Rubber Co.

The following special dispatch sent out from Batavia, N. Y., under date of February 26, is of special interest because of Mr. Caney's long and favorable connection with the vehicle trade:

Ashton W. Caney, president and active manager of the Batavia Rubber Co., and one of its original incorporators, has sold the greater portion of his stock and will retire from an active position with the company on March 1, although he will continue his connection with the corporation as one of its directors. It is expected that his successor will be named at a meeting of the directors on March 1. Mr. Caney has been for 17 years actively engaged in the rubber business, first with an Akron, O., concern, for which he traveled during the year of 1899. In 1900 he became interested in the Batavia Rubber Tire Co. and represented that concern in introducing the Sweet patent solid rubber carriage tire. The business was successful and in connection with the Batavia Carriage Wheel Co. it was sold to the Standard Anti-Friction Co. of New York, Mr. Caney remaining with the latter company until August 1, 1902, when the rubber tire business had assumed such proportions that he resigned as manager of the rubber department of the Standard company, and, with other Batavians, organized the Sweet Tire and Rubber Co. of Batavia.

Sohlinger Sales Manager Flint Varnish

Walter J. Sohlinger, well known throughout the vehicle and automobile industry, recently became associated with the Flint (Mich.) Varnish and Color Works, in the capacity of sales manager. Mr. Sohlinger was formerly identified with Sherwin-Williams Co., Cleveland, O., and the Lowe Bros. Co., Dayton, O., resigning from the last named concern to accept the present position.

Rittman Process Only Hope in Gasoline Situation

The only hope for the speedy reduction in the high prices for gasoline, according to Van H. Manning, the director of the United States Bureau of Mines, Department of the Interior, lies in the immediate development of the so-called Rittman cracking process and similar processes. He declares that the prevailing prices may not only continue for some time but will undoubtedly reach higher levels before there is any permanent relief. He points to the fact that the oil companies, in competition to supply the United States government for the next fiscal year, have offered gasoline at 31½ cents a gallon for the whole year, and argues from this that, if the United States, using vast quantities of gasoline, is compelled to pay this much the private consumer will have to pay much more. Furthermore, Mr. Manning says that with a rate of production the same as in 1915 the crude oil supply of the United States, from which we are getting our present supply of gasoline, will be exhausted in 27 years.

"The situation is even worse," said Mr. Manning, "for the production is not going to remain stationary. The demand for gasoline has increased more than 200 per cent in the last five years and is now increasing at an even faster rate. On January 1 of this year there were 2,225,000 automobiles in use, and automobile manufacturers estimate that this will be increased to 3,000,000 by January 1, 1917. As the average automobile will use more than 10 barrels of gasoline a year, this means an increased consumption of more than 6,000,000 barrels of gasoline.

"And what is still more important to the situation, present indications forecast a decreased production of gasoline from crude oil for 1916 rather than an increased production. The daily production of crude oil for February in the Mid-Continent field, which produces 75 per cent of our refinable crude oil, was 40,000 barrels less than the average daily production for 1915, and 20,000 barrels less per day than the average daily production in 1914, and this is in the face of the strong incentive to find new fields given by the rising market of the past six months, which has culminated in record high prices for that field of \$1.55 per barrel for the crude, with, in some cases, a premium exceeding 40 cents a barrel.

"The demand for gasoline has outstripped the demand for all other petroleum products with the result that these other products, amounting to about 75 per cent of the production, are being sold for less than the cost of production. In other words, 25 per cent of the production consisting chiefly of gasoline, must pay all costs in addition to the amount that is lost in marketing the remaining 75 per cent.

"We are exporting at the present time 20 per cent of our entire production of crude petroleum, including 16 per cent of our gasoline production. We are burning 25 per cent of our petroleum under boilers, which is a shameful and criminal waste of precious natural resources and we are using another 20 per cent of our crude petroleum inefficiently in competition with coal as in the manufacture of artificial gas. Three-fourths of the entire amount of artificial gas in this country is made from petroleum. This gas could be made from coal, except that the gas manufacturers are able to make it at less cost from

petroleum, owing to the lower cost of oil as against coal. It is needless to say that petroleum should not be used for this purpose.

"The solution of the problem is conservation—our petroleum resources being put to their proper uses. Let us stop this wasteful foolishness of burning petroleum under boilers and the use of crude oil in the making of artificial gas. If by means of cracking processes, such as the Rittman process, our kerosene and fuel oils, which we have been using in competition with coal and selling for less than the cost of production, can be converted into gasoline, the present production of crude petroleum would be more than ample to supply our present demands for gasoline. Not only that, but the general adoption of these processes would result in extending the life of our petroleum deposits, based on the present demands, from 27 years to more than 100 years, at the same time reducing and stabilizing the cost of gasoline to the consumer and preventing rapid fluctuations in price. Ten different refineries are now installing the Rittman process and more companies are considering doing so. This is but a drop in the bucket, but the situation is hopeful.

"The importance of petroleum cannot be measured by dollars and cents. Figures cannot convey an idea of the dependence of many industries upon petroleum products of one kind or another. Lubricating oils, all of which come from petroleum, are absolutely necessary to our very existence. It has been computed that the machinery of the nation requires approximately one gallon of lubricating oil to each 300 horsepower per day, roughly speaking. Every automobile built but adds to the demand for lubricating oil; every ship launched; every car; every locomotive, must be supplied with lubricants, and petroleum is the only known source of supply. Today we are burning this precious lubricating oil under boilers as fuel oil, without adequate financial reward and with utter disregard to the nation's future requirements. One student of the oil situation says that through the wasteful use of the petroleum resources the United States is now confronted with a national crisis of the first magnitude, and he may not be far wrong."

Barcelona Conditions Favor Electric Vehicles

Although there is in Barcelona, Spain, a supply of electricity available for charging electric trucks and passenger automobiles, such vehicles are not seen there, writes Consul General Carl Bailey Hurst.

In this district the nature and condition of the highways outside the cities are not conducive to the use of motor vehicles for either pleasure or commercial purposes. The local demand, then, is essentially for a car to be used almost entirely in town and suburbs, where the streets are of asphalt, blocks or macadam.

The country is hilly, and even the city has appreciable grades, which complicate the operation of cars and require efficient brakes. Women rarely operate automobiles here, but many of the owners of the somewhat more than 2,100 machines now registered in this city at times drive their cars. There is no apparent reason why, with the price of gasoline approximately 60 cents a gallon, electric passenger vehicles should not find a market here in view of their usually good appearance, a characteristic very generally demanded by local purchasers. It would seem, too, that electric trucks might be introduced for the important carrying trade of this city.

Adjustable Springs

I have on more than one occasion suggested the desirability of some better system of springing cars than we have at present, pointing out that, to obtain perfect springing, the springs should be exactly proportionate to the load, and that, as the load varies, the spring system on any particular car can only be just right for one specific load, so that, when either more heavily or more lightly loaded than the exact weight for which the springs are designed, the springing will be inaccurate and the riding consequently less smooth and satisfactory than it should be.

Some designers, in working out the proportions of their springs, aim at hitting a happy medium as a rule; but others spring the chassis for the heaviest load the car is constructed to carry, so that, for example, if a car is fitted with a five-seated body, the chassis will be sprung on the assumption that it will be loaded when in use with the particular body for which the springing is designed, plus five people of average weight, so that, when less than the full seating capacity of the car is occupied, the riding will be more or less harsh. This, of course, will be accentuated where the possible range of load is greater, as, for example, in a seven-seated car, or in an ambulance arranged to carry six, but which, on the other hand, in this latter connection it is of the highest importance that the

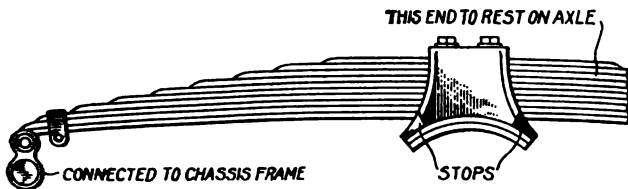

Fig. 1. Spring and Quadrant

springing should be as easy as possible for however many or few cases there may be on board.

Where commercial vehicles are concerned, the need for adjustable or adaptable springing becomes greater still, as the difference between the load upon the springs in, say, a three-ton chassis when fully loaded and when traveling empty is very great. But we need not trouble ourselves at the moment with commercial vehicles. The highest efficiency of springing is desired for the comfort of the passengers, and not only the load, but the nature of road and average traveling speed, will also be points which will more or less affect the result attained by our springing, so that all these factors have to be considered before we can hope to get perfection.

It will be seen, therefore, that perfection cannot be obtained from any non-adaptable system, and that the best we can do with such is to arrive at a compromise. Hence it was with a considerable amount of interest that I heard some little time ago of a new idea in the direction of an adjusting spring system, and I am pleased to be able to give details of this device, which is now being applied with considerable success in practice.

The system is really extremely simple. The efficiency of a spring depends very largely upon its length between unsupported points, and the method of securing adjustability is to vary the length between the supports, thus giving a greater or less length for free play as the occasion may require. For this purpose, the inventor adopts the cantilever form of springing, which consists of a long

but slightly arched spring resting on the axle at one end and supported on the frame both at its center and at the forward end, which, being shackled, can accommodate itself to the variations in length caused by spring flexion under load. While, therefore, the center and forward end of the spring are both attached to the chassis, the tail extremity rests only upon the axle, and this end partakes of the fullest movement under the undulatory action of

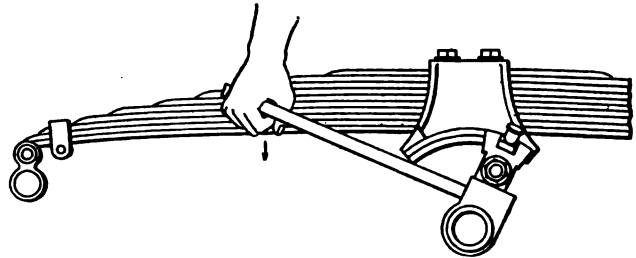

Fig. 2. Spring set stiff and the operating bar in position

the wheels in travel. The new plan varies the length of this free rear end, or, rather, he varies the position of the point of central support, as will be seen by the annexed illustrations. As shown, the central attachment of the spring to the frame consists of a box containing the center of the spring plates, which, instead of being bolted direct to the side of the chassis frame as usual, rests upon a support carried free of the frame, but resting upon a bearing rotatably mounted upon the end of a tube running across the chassis below the frame and supported by brackets depending from it. The under portion of the spring box is arched to correspond with the arc described by the supporting bracket around its center of movement on the supporting tube end, the base being so shaped as to engage with suitably shaped guides in the side blocks, which serve to connect it with the rotatable bracket in such a way that the movement of these sides is limited by stops and so prevented from leaving the spring box altogether.

Now it will be seen that if this movable bracket, which may be set at any point between its limits of movements, is set in a central or vertical position, the effect upon the spring will be the same as with an ordinary cantilever spring supported to the frame sides at its central point, and, so set, the springing may be termed normal. For

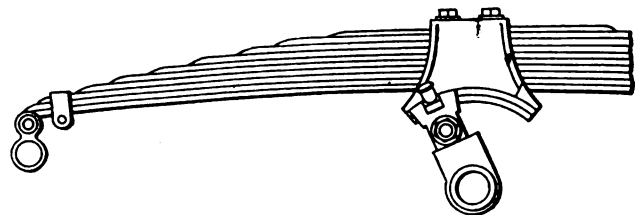

Fig. 3. -Showing the spring set weak

heavier or lighter loads, the rotatable supporting bracket is moved around its support either toward the front or rear end of the spring box as may be required, this movement being effected, after the loosening of a nut, by a lever inserted in a socket in the bracket, as shown in the illustration. With the leverage for this purpose, this is not a difficult matter, and the adjusting lever is arranged to be carried by spring clips on the inside of the chassis frame, so that it is always handy. It will thus be seen that, when the bracket is moved to a rearward

position, the length of the free end of the spring is shortened, which results in making the spring stiffer; while, when moved in the other direction, the center of support being further forward, the free length of the spring end is increased, giving greater play and more flexibility. Mr. North, in his spring, dispenses with the usual shackle at the front end of the spring, and anchors this end firmly there, if it is intended to take the driving and braking stresses through the springs; but where a separate torque system is provided, a shackle is used for the attachment of the spring to the rear axle.

As the springs are designed, the ratios of maximum to minimum stiffness is 1.55 to 1, so that, roughly speaking, with the point of support shifted to its rearmost position, the spring is half as stiff again as when the foremost point of support is employed. This certainly appears, as I have already said, to carry out the idea of adjustability in an extremely simple as well as a most efficient manner, and it will be interesting to note how this new advantage provided for the user for the increase of his comfort is accepted by trade and public. To me, the idea appears to be an excellent one and worth the careful consideration of designers generally.—Henry Sturmey, in *Motor* [London].

Real Horse Power

Here, you high school students, is a fine mathematical problem based on a feat performed in San Francisco one day in February. The feat which we describe was performed on a Sunday, so as to avoid the congested wagon and motor truck traffic of the week-days.

Thousands of churchgoers and Sabbath morning pedestrians watched two 40-horse teams pulling two giant cable-reels mounted on huge trucks from the American Steel & Wire Company, Sixteenth and Folsom streets, to the plant of the California Street Railway Company, Hyde and California streets.

The largest of cables, including the great reel carriage, weighed 26 tons. Horsepower, as is generally known, is a standard theoretical unit of the rate of work, equal to 33,000 pounds lifted one foot high in one minute.

The 40 horses moved the giant cable of 26 tons, or 52,000 pounds, a mile and a half, or 7,920 feet, in 60 minutes.

The problem is how much horsepower was actually expended during the moving of the cable.

The largest cable is 18,000 feet long. It will be used in California street, between Presidio avenue and Hyde street. The smaller cable weighs nineteen tons and is 14,000 feet long. It will be used to pull cars between Drumm and Hyde streets. The two cables cost \$10,000, and their life-time covers about fifteen months.

A Forty-Horse Team

The forty dray horses, presenting a superb array of animal strength, commanded the admiration of the thousands of onlookers. At corners the crews of each truck, consisting of three drivers and two brakemen, displayed their traffic generalship.

It was necessary to swing the trucks around corners by sending the horses over the curve ten abreast. Even leverage was thus brought to bear on the mast-like truck tongues. Ten men assisted alongside each truck. No accident occurred in spite of five grades encountered along the mile-and-a-half journey.

Several Sunday-school meetings were disturbed through the children being attracted to the windows by the rumbling of the passing loads, but on the whole the long pull was accomplished with the absence of much squeaking and groaning.

Traffic on the main highways was not interfered with, the horses digging in with their iron-shod hoofs snorting cones of vapor from their nostrils giving them the appearance of dashing chariot steeds.

The Farm Horse and the Auto

About the only difference that the automobile makes to the farm horse is that when the automobile is used, one or two horses get a rest instead of a stiff work-out on the roads. This is about the only difference. It puts the horses in better condition when they are required.

It is true that where hard roads have been extended farmers can, at any time, get out from home to the town or among their neighbors, but it is only the few who live directly upon the improved highway that have this privilege. A mile of mud, or even a small area of quagmire on the road is an effective barrier to automobile travel—as effective a hindrance as miles of mud—and so all who live off the hard road must fall back on the horse to get away from home, at least to get as far as where the hard roads begin.

It may be a generation or two before any large proportion of the farming population of America can travel by automobile without regard to the condition of the roads. They will find the horse an indispensable traveling assistant during the winter and spring, and also very frequently at other seasons of the year.

There will always be a demand for horse-drawn vehicles despite all other modes of transportation, and vehicle dealers who keep a live and well assorted stock, clean, bright and well displayed, are finding ample justification for their loyalty to the buggy business.

Anybody living in a country town can tell just what condition the roads are in without asking any questions. If many automobiles come into town, the roads are good. If the hitching racks are thickly lined with teams, the mud is deep. One day automobiles are numerous on the dirt roads and buggies are few, while motor trucks with heavy loads skim along the highways at from ten to fifteen miles an hour. The next day a rain comes and the power vehicles are relegated to a temporary discard. These facts being taken into consideration, the horse is indispensable. Evidently the automobiles on farms are not displacing many of the horses. Automobiles are used to assist the horse in his work, to cooperate with him, but not necessarily to displace him.

Flint Varnish and Color Works of Canada

Officials of the Flint (Mich.) Varnish and Color Works announce the formation of the Flint Varnish and Color Works, Ltd., of Canada, capitalized at \$250,000. The Canadian plant will be located in Toronto, in the factory buildings formerly occupied by the Dominion Carriage Co., and which consist of a three-story building, 250 x 82 ft., and a one-story building, 250 x 60 ft. A one-story structure, 120 x 120 ft., will be erected for melting, thinning and treating gums used in the manufacture of varnish.

Kerosene as Fuel

The present high price of gasoline has naturally led many motorists to seek alternative fuels which will give approximately the same results but at a lower cost.

In England, where the matter of fuel economy has been seriously considered for some time on account of conditions brought about by the war, much thought has been given to the subject. The following article and illustration is taken from a London publication along with a criticism by a correspondent in a subsequent issue of the same publication.

Kerosene is unsuitable for use in an ordinary internal combustion engine designed to run on gasoline. For a kerosene engine to give the best results it must have a comparatively high compression, and special arrangements have to be made, so that every atom of liquid fuel is vaporized. The presence of unvaporized molecules of kerosene will cause incomplete combustion to take place, and will result in a sooty deposit, which in time will cause preignition and also give an offensive exhaust. It is therefore, out of the question to use kerosene by itself as a fuel on an ordinary motor car engine unless some special form of carbureter is obtained.

The only possible solution of the fuel problem is to use a mixture of kerosene and gasoline and on the proportions of the mixture depends the success or failure of the experiment. The ordinary type of car carbureter, in conjunction

with the normal type of motor engine, will give quite satisfactory results on a kerosene mixture in which a large proportion of gasoline is present, until such time as the engine is called upon to give its maximum power. With an appreciable quantity of kerosene in the mixture, unsatisfactory results are then obtained.

It will therefore be seen that to obtain the most satisfactory results both on the level and uphill, it is necessary that the driver should be able to control the proportions of the mixture. It is therefore essential that two separate tanks should be employed in order to obtain the best results—one to contain kerosene and the other gasoline. Separate screw-down taps should be provided on each fuel line, so that the amount of kerosene in the mixture can be adjusted.

With the controlling devices for the taps mounted near the driver's hand it will be possible to run on the level and down hill on a mixture which is very rich in kerosene, but when hill climbing is undertaken the kerosene can be cut down until, in order to obtain the maximum power, gasoline alone is employed.

In order to obtain the best results from a gasoline and kerosene mixture, it is essential that the carbureter or the induction pipe should be properly heated. Too little attention is usually paid to this when gasoline alone is used, but it is absolutely essential if proper combustion

of kerosene is to be obtained that the exhaust gases shall be made to circulate round the induction pipe, or, alternatively, the cooling water shall be made use of.

Certain chemically-minded owners may not be prepared to go to the expense of a separate tank, to carry the kerosene and the piping and taps necessary, and in that case a kerosene mixture of constant strength may be employed. Engines vary so much in their performances that it is impossible to give any hard and fast rule as to the proportions which will be most suitable. This would naturally be the subject for experiment, but as a beginning a proportion of two gallons of gasoline to one of good grade kerosene may be tried. The proportion of kerosene may be increased from time to time until a satisfactory compromise is effected between economy and power.

It should be remembered that the greater the amount of kerosene in the mixture the more difficult it will be to start from cold, and in this connection compression taps

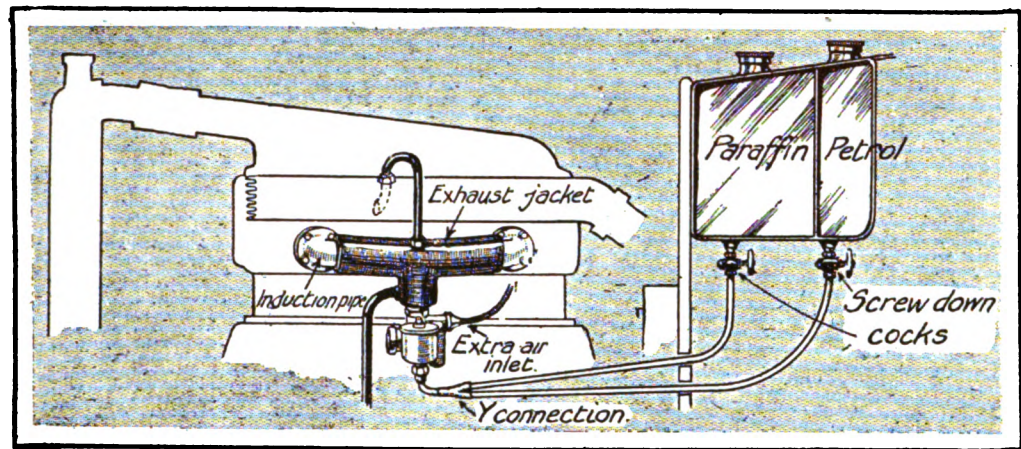

How motor car engine can be modified to run on a gasoline-kerosene mixture. Two independent tanks are provided, with the flow of each fuel controlled by screw-down cocks. The inlet pipe is well heated, while an air inlet allows mixture corrections to be made when running.

through which an injection of gasoline may be made will be found of great use.

It is generally found that when kerosene is used, a greater mileage per gallon is obtained, and thus the private owner who is using the kerosene mixture will obtain his fuel at a cheaper rate and will travel a greater number of miles on each gallon thereof. It will be seen that experiments in this direction may result in marked economy.

ANOTHER VIEW

A correspondent, in commenting on the foregoing article, wrote:

I think a great deal of caution should be exercised before kerosene is used in any motor engine that is not fitted with a thoroughly efficient vaporizer. Your correspondent says that the compression should be higher when using kerosene. This is absolutely incorrect. One of the great drawbacks in using kerosene for pleasure-car engines is that compression is too high; moreover, the use of kerosene is exceedingly bad for many engines. There have been scores of engines seriously damaged by its use. What happens is this, you mix kerosene and gasoline together. Kerosene is drawn up and does not vaporize and runs in the cylinder liquid, it then runs down past the rings and gets into the oil in the crank-

case, and it is only a matter of time before the white metal bearings get melted out. As I have been through every phase of the subject I feel that I can speak with some authority. Of course, no doubt numbers of your readers will say at once this is nonsense as they have used kerosene and are using it. I do not say it is impossible to use kerosene in motor engines, but I say that its use in 99 cases out of 100 is either unsatisfactory or dangerous.

Treated Wood Block Flooring

Creosoted wood blocks, already extensively used as paving material for city streets, have been coming into use as flooring for the last four or five years, according to the Forest Service. Its durability, noiselessness under heavy traffic, and sanitary properties are its chief advantages for paving and also give it special value for making floors, especially for use where heavy trucking, the moving of heavy machinery, or other severe use makes the maintenance of floors a serious problem. Its rather high cost is its chief disadvantage.

Wood block is now widely used for flooring in factories, warehouses, machine shops, foundries, various types of platforms, wharves, and docks, and for such miscellaneous purposes as hotel kitchens, hospitals, laundries, and slaughter houses. Possibly one of the oddest of these uses is for the floors of animal cages and runways. Notwithstanding the recent increase in the use of wood block for these purposes, it is believed that the growth of this industry will be even more rapid in the future. These floors are well liked by the workmen because they are easy on the feet.

Most of the blocks for these floors are now made of southern yellow pine. Hemlock, larch, Douglas fir, black gum, beech and maple are also used. The blocks are sawed from long sticks of timber and are treated in huge steel cylinders from 6 to 7 feet in diameter and 100 feet or more in length. Creosote oil is run into the cylinders and pressure is then applied to force it into the wood. The oil is a product obtained in the manufacture of coke from coal and its purpose is to prevent decay of the wood, and also to prevent shrinking and swelling of the floor after it is laid.

The blocks are laid with the grain vertical, so that the most wear-resistant surface is exposed, and usually on a concrete foundation. The joints or cracks between the blocks are then filled with hot paving pitch or asphalt which binds the many separate pieces into one continuous surface. According to the experts, the cost of creosoted wood-block floors averages about \$1.50 per square yard for the blocks alone and about \$2.40 per square yard for the completed floor.

For best results these floors should be laid under competent supervision, for unless certain fundamental rules are followed trouble is very liable to ensue. Most of the trouble is caused by the swelling or the shrinking of the wood, due to changes in content of moisture, difficulties which may be guaranteed against, however, by carefully following the most approved methods.

Higher Demurrage Rates

An increase in demurrage charges upon cars held more than three days after the expiration of the free time allowed for loading and unloading has been made effective under special permission of the Interstate Commerce

Commission. The new rules, published on April 1 or as soon thereafter as carriers could issue their tariffs, provide for a charge of \$2 per car per day for the fourth and all succeeding days during which a car is under car service charges. The old rate of \$1 per car per day will still apply for the first three days after the expiration of free time.

Tariffs carrying this advanced charge were filed under special permission granted by the Interstate Commerce Commission a few days ago. This permission was necessary in order to permit the higher rate to become effective upon less than the statutory notice of 30 days. In some cases it was also necessary to obtain permission for this short notice filing from various state commissions.

The new rate is put in in an attempt to relieve the serious congestion of equipment at eastern terminals and to increase the available car supply for loading on western lines. Its imposition has the endorsement of the National Industrial Traffic League. By agreement, the tariffs carrying the higher charge will expire on June 15. No change is made in the average agreement plan or practice except that the credits earned thereunder can not be used to offset any part of the charges in excess of \$1 per day.

Philadelphia Vehicle Builders Elect Officers

The Carriage and Wagon Builders' Association of Philadelphia celebrated its twenty-first annual meeting at the Hotel Hanover, Twelfth and Arch streets, on Friday evening, March 17, 1916. The annual payments for dues were made at this meeting and subjects of interest to the local vehicle trade were discussed, and the following were elected to serve during the coming year:

President, Thomas Quirk; vice-presidents, Emil Insigner, B. R. Richards, William Freidrich; secretary, Henry F. Keachline; treasurer, Frank Schanz; executive committee, William E. Marbaker, August Geissel, Jr., John Dengleden, Max Moehrle, Charles Wachter, Albert Kohler, H. Kerstein.

After the business session the members adjourned to the dining room of the Hanover, where the usual monthly dinner was served. It being St. Patrick's Day, the table decorations were in keeping with the occasion.

The twenty-first annual banquet of the association was held on Thursday evening, March 30, at the Hotel Hanover. Hon. Edward J. Cattell, city statistician of Philadelphia, was the guest of honor and the principal speaker. Other speeches were made by Messrs. Preisendanz, Keachline, Schanz, Geissel and Marbaker. President Thomas Quirk was toastmaster.

The banquet began promptly at 8:30 and lasted until shortly after 11 o'clock. From 11:30 until 1 o'clock dancing was indulged in to the accompaniment of excellent music furnished by the hotel orchestra.

Wagons at Bottom of Ocean

One hundred and eight Troy wagons, made by the Troy Wagon Works, at Troy, O., and valued at \$55,000, are at the bottom of the sea, some place between New York and Archangel, Russia. The loss is presumably the work of German submarines, as the shipment was signed to the Russian government. The shipment was paid for before it left Troy.

Paint Shop

Comparative Merits of Varnish and Enamels

Motor car owners who desire to shirk the trouble of cleaning their cars sometimes complain of the ease with which varnish surfaces become soiled and lose their gloss. They inquire if there is not something harder than varnish which will more efficiently resist the wear and tear. The answer given sometimes is that enamels offer advantages over varnishes. The majority of people unfamiliar with painting and enameling connect the latter with some of the processes employed for finishing iron or wood articles for use or ornament. Upon this question, however, it is interesting to note the experience of practical men who expressed opinions on the subject at a recent annual convention of Master Car and Locomotive Painters' Association of the United States of America and Canada. The question for discussion was, "Will Equipment Finished in Enamel or Varnish Color Wear and Clean Up in Service as Easily and Economically as the Varnish Finish?" In a paper read by E. B. Stair, the latter made the following statement:

"On thinking over this proposition, it seems to me there is only one answer to it, especially when considering an exterior finish, and that answer is 'No.' During some years' experience as a master painter it has been my good fortune to work for people, who, as a whole, exact a better quality of finish on the exterior than can be obtained from the use of enamel or varnish color. I have yet to see an enamel or varnish color that after being applied has the luster one gets from the clear varnish of good quality.

"During the past year I have tried on engines at our shops in Montgomery a black enamel that was recommended for fine gloss and to be more durable than engine-finishing varnish. We applied this enamel to several jobs, cabs and tanks, with the result that we had no such luster as has been our custom to get from the engine-finishing varnish.

"After these jobs had been in service some months, I noticed there was a loss of luster we do not have in so short a time from the use of engine-finishing varnish, and I also observed these jobs did not clean up as easily and with as satisfactory results as we get from engine-finish varnish jobs.

"Several years ago, on trying a body enamel Pullman color as a finishing coat on the exterior of several coaches, we found the working qualities of the product anything but a pleasure to apply. The appearance of the job when coated, was not as satisfactory, to my mind, as that obtained from varnish finish, and I had occasion to notice later that the enamel did not wear as well, nor clean up as easily nor as cheaply as do the varnish finish jobs.

"Among its equipment the Atlanta and West Point has a number of steel postal cars that had been finished on interior with white enamel, and I have reason to know that it is quite a bit more expensive to clean up one of these interiors than it is to clean an interior that has had a coat of rubbing, copal or inside finish varnish over the

enamel or finish color. The smoke, dirt or matter that accumulates on the interior of a postal car finished in white enamel or varnish color, on attempting to clean same with soap and water after being in service several months, I have found that quite a portion of this dirt had penetrated into the enamel or varnish color, and to get a good job of terminal cleaning under such conditions is almost what Sherman said war was.

"From these experiences, and others in connection with enamels and varnish colors, I am of opinion that equipment finished with enamel or varnish color will not wear as well nor clean up in service as easily and economically as varnish finish."

In a second paper upon the same subject, the writer says:

"Will it be necessary to shop for revarnishing or painting more frequently? To answer this we would say that depends entirely upon the quality of the material used. To put this in another way: Suppose we should bring up two jobs to the finishing point; finish one with an enamel or varnish color made with a high grade of varnish and strong color, the other finished with a low grade varnish. The two jobs receiving the same treatment in service, we would decidedly prefer to take a chance on the enamel or varnish color. On the other hand using the strongest color obtainable in making the enamel or varnish color, and use the same grade of varnish in finishing a similar job, we will unquestionably have the most satisfactory job in every respect in the varnish finish."

At the conclusion of the discussion which followed, the following resolution was made by the convention:

"That it is the sense of this association that a varnish finish on exterior work is superior in durability and economy to an enamel finish."

Spacing Letters

When a lad learns signwriting from books or in a technical college he concentrates his attention on the shape of the letters. He is not satisfied until he has freed his letters from conspicuous faults. That is to say, the letters are (1) of correct general shape, (2) balance well, (3) are of correct relative width, and (4) horizontal and upright bars are of proper thickness. But there is more than this in making a good sign. The letters have to be properly put together. This entails the exercise of judgment and, though the problem presented here is much less difficult than that of correctly drawing letters, it is still one of the most important features in sign work. As a matter of fact, in a good sign the letters may be faulty in shape as long as the spacing is good, but a faulty spaced sign never looks well, however correct the shape of the individual letters may be.

The term spacing applies to (1) the space between individual letters of a word, (2) the space between one letter and another, (3) between one word and another, (4) after initial letters, and (5) the general arrangement of the words and lines of letters on the surface of the sign.

One of the chief faults of a beginner is to crowd letters. He soon learns that boldness is a valuable feature in a sign. This encourages him to make letters too heavy and too close together. It is the fault of a generous nature, which wants to give the customer more for his money than the limits of the sign will permit. There are types of poster letters which are the better for being of heavy proportions and close together, but they are exceptions. The fault, of course, may be in the other direction and the letters appear starved and mean.

But the man who escapes most of the possible errors of spacing is found sometimes committing that of placing, not letters, but words too close together, or putting the initials before a proper name so close that they sometimes seem part of the name. From a suburban train the writer frequently passes a nicely lettered gold sign. The sign writer's name at the bottom of the sign, which is not unlike "E. Vernon," appears from a distance as "Evernon." This is the outcome of bad spacing. It is important to accentuate the space and the stop between an initial letter and a name. With some writers it is the practice, in spacing out a line of letters, to consider the space between initials and between words as equal to the width of a letter. This gives ample working room, and lessens crowding.

Sign writers, says Australasian Coachbuilder and Wheelwright, are peculiarly apt to minimize the importance of the first letter of a word. In the first place in the bulk of their work they use exclusively the capital letter, and do not usually make the first letter of a word larger. It would be advantageous not to rely so much upon the capitals but, on the other hand, to make a more liberal use of lower case, and when the capitals are used throughout, to make the commencing letter of each word larger. Be the increase ever so slight, it accentuates the importance of the first letter of the name or word. When increasing the size of letters at the beginning it is well to keep them slender. They should not be thickened in the proportion that their height is increased. Accentuate the size not the weight.

Lighter Colors are Most Efficient for Cars

In writing of the drawbacks and disadvantages of the blacks and blues and greens, the two latter of the deepest shade, as colors for use upon automobiles, M. C. Hillick, in *Automobile*, says: These pigments, it must be conceded, are, at the outset of their career on the surface of the car, and when given the full radiance of a fine fabric of varnish, exceedingly beautiful to behold, and if they could be made to wear on with the same magnificent effects, and at the minimum outlay of cleaning processes be maintained at a high rate of efficiency under the stress of everyday service, their value and usefulness would pass unquestioned. Unfortunately this is not the case, and wherever these colors are found doing service on the average American highway, there you may expect to find difficulty in keeping them clean and neat, and showing a reasonable amount of luster. Moreover, they are colors ground in Japan, and therefore afflicted with a brittleness which under severe road and garage treatment is certain to suffer. They will, of course, give a better account of themselves if kept well protected under an ample supply of varnish, but in the face of all that may be done for them—speaking now of the colors upon the cars exposed to the conditions of the average

country and village highway—the tendency is to show a dingy, unkempt, and generally unsatisfactory appearance.

The exception to this rule is the color used upon the car employed for service upon city pavements, where the conditions of service are of a modified order, as compared to those encountered in the rural districts. These black, deep blue and green colors require a dressing-up with some of the ornamental embroidery of relief colors to take them from under the funereal aspects which such field colors always invite. In other words, they require an artificial stimulation to keep them in presentable condition for even a temporary show.

In respect to the employment of lighter colors, such, for example, as maroon, some of the browns, the grays, creams, wine, and the lakes. These colors, some of them also ground in Japan, have the important advantage of being comparatively easy to clean up and to be kept clean. Also, they retain their brilliancy of effect to the maximum limit. They show dirt less than darker colors, and respond to the cleaning operations quicker. They render service in proportion to the attention bestowed upon them but at the same time they flourish under neglect and display color effects that would make the darker pigments look like a vain show. The grays, and the creams, and lighter yellows, all are permanent pigments by virtue of the ingredients composing them, white lead being an important one, and a basic feature of the greatest value as a surfacing medium. Such a pigment, naturally supple and elastic, imparts to the color a surfacing property, a density of fiber and film, and an elasticity quite unsurpassed, and explains the tenacity and the durability which characterize these pigments with a pronounced lead base. Give these colors a proper fabric of varnish, and a decent measure of care taken, including proper washing processes, and the service they will render cannot fail to equal that of the very best pigments.

Practically all these colors stand washing and cleaning operations excellently, which may be accepted as evidence of their durability and strength of film. Likewise, they show road dirt and the accumulations of the highway less than the darker colors. They require less of the ornamental effects to bring them into notice, the field color being capable of making an impression without the aid of any ornamental lines, although, of course, these lines serve to lighten the effect and bring into greater relief the true and distinctive character of the field color.

All colors having a portion of white lead in their composition may be accepted as pigments of an elastic nature, and capable, under reasonable conditions, of giving a masterful measure of durability, at the least possible outlay on cleaning and renovating. The black and the darker colors referred to fail in the capacity to stand the renovating processes without detriment, especially when the protection of varnish has become of no effect, whereas the lighter colors bear these erosives with fewer indications of injury to their luster and general appearance. In making choice of color for the car, its class of service may well govern the selection.

Polishing the Automobile

The automobile repairman, if he is to offer complete service to the automobile owner, will need to know something about how to brighten and renew the polish on the body of the automobile. Simply because the body appears dull and lusterless is no reason to suppose that it

will require a coat of paint or varnish in order to restore its brilliancy. If the body has not gone too long and has not been exposed to nature's elements to an unreasonable degree, an application of some suitable body polish will usually brighten it considerably.

Dust, rain, sun and mud are all enemies of the high gloss finish on the automobile. Washing an automobile is usually considered such a disagreeable job that the automobile owner will let it go just about as long as he can. Procrastination in this case allows nature's elements to get in their very damaging work on the fine finish of the car and after this process is repeated several times, the auto owner wonders where the high gloss finish has gone which he purchased with the car.

It is here, says L. M. Havlin, in *American Blacksmith*, that the progressive auto repairman can come to the auto owner's aid and in doing so, incidentally gather a few shekels into his own pocket. To proceed with the rejuvenation of a motor car body, it is, of course, absolutely necessary that all dust, dirt, grease and mud be removed from its surface and that the part to be polished be carefully dried. A number of polishes can be used and there are practically no end of furniture polishes on the market. Polishing wax is also used to some extent and seems to be very satisfactory. There is no reason why the automobile owner cannot make his own polish as the ingredients of these polishes are very inexpensive, and if he has any considerable amount of work to do he will not be paying out any great amount for polish.

A very good polish that can be used on practically all kinds of varnished surfaces is made as follows: To 2 quarts of turpentine, add $\frac{1}{2}$ pint of paraffine oil, $1\frac{3}{4}$ ounces of citronella and $\frac{3}{4}$ of an ounce of oil of cedar. This mixture is well shaken while using and is applied in the usual way, using a soft flannel cloth for polishing. In using this or any other polish, do not be afraid to mix with it plenty of "elbow grease." Used in this way even an old, lusterless car body can be restored to a certain degree of brightness and freshness.

Cleaning Paint Cans

The simplest way to strip paint kettles is to boil them in strong caustic soda, which will very soon remove all the paint. They should be washed in a second tank of clear water, to which a little vinegar is added, in order to kill the caustic, and then have a further washing in pure water.—The Decorator.

Clairvoyant Bank Manager

In the later half of last year—so runs a London legend—an officer called on his bank manager with regard to certain dispositions of his balance preparatory to his departure for the front.

"You won't be away long," said the manager.

"How do you know?" was the reply.

"You will be back in quite short time, wounded in the hand."

When the officer actually returned, with a wounded hand, and in a short time, he was puzzled. However, his wound healed, and he was off again. He went to bid "Good-by" at the bank.

"Any more prophecies?" said he, jocularly.

"You will be away longer this time," replied the mana-

ger, "and then you will be rather badly wounded in the leg."

When the officer was wounded in the leg and came home, he sought the first chance to interview his far-seeing friend at the bank.

"As you can foretell my wounds, can't you give me the date of the end of the war?" he asked.

"The war will end," said the manager, "on June 17 next. But I shan't live to witness it. I shall just about see New Year's Day, and that's all."

He died on January 2. The officer is now looking forward with extraordinary interest to June 17.—London Financial News.

Removing Dints in Sheet Metal

Deep dints in thin sheet metal articles, such as horns, tanks and panels, which cannot be straightened out by expert hammering, can often be made passable by the following method. A rough wire handle must be made as sketched, and the center of the hollow in the dint must be cleaned of any paint or grease and then tinned with soft solder. While the metal is still hot, the wire handle is placed to stand vertically in the hollow, and molten solder is poured round it.

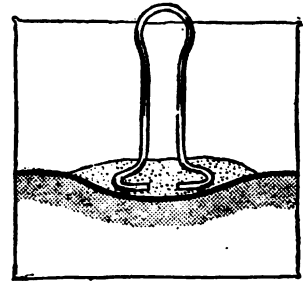

When cold, the handle will be found to be embedded in a solid mass of solder. By pulling slowly and steadily at the handle the dented portion can now be raised uniformly and restored to its original shape. It helps matters considerably if the article allows a certain amount of pressure to be applied to the back of the depression. All traces of the solder should be afterwards removed by the application of the heat.—Auto-Car.

By-Products of the American Lumber Industry

Prof. H. K. Benson has completed a careful study of the progress being made in this country in utilizing the billions of feet of wood that have hitherto been wasted. The Bureau of Foreign and Domestic Commerce has published the results of this investigation in the form of a bulletin which it is anxious to place in the hands of every person and concern directly connected or indirectly interested in this subject.

The report includes chapters on wood distillation, the manufacture of tannin extract, the production of wood pulp, the manufacture of ethyl alcohol from sawdust, the manufacture of producer gas, and the progress that has been made in manufacturing a number of minor wood products. Prof. Benson has described the processes in use, but he has also paid particular attention to the commercial obstacles that have stood in the way of a more rapid development of some lines. When the war is over a study will be made of these industries in the European countries where they have been highly developed.

The bulletin is entitled "By-products of the Lumber Industry," Special Agents Series No. 110, and is sold for the nominal price of 10 cents by the District Offices of the Bureau of Foreign and Domestic Commerce and by the Superintendent of Documents, Washington.

Cincinnati C. M. C. Election

The annual election of the Carriage Makers' Club was held at the Business Men's Club on March 9, with 44 members present, two guests of the club and two guests of members.

Mr. Luth reported that W. H. Young has decided to withdraw his resignation. This was pleasing news, as Mr. Young is one of the hardest workers of the club.

A letter was read from the Implement, Vehicle and Hardware Association of St. Louis, thanking the club for the royal entertainment and hospitality shown their members, Messrs. P. E. Ebrenz, W. H. Roninger, Norman Champ, and Thomas Price, while visiting Cincinnati.

Ed. Sendelbach expressed his views on the present outlook of prosperity throughout the country.

The speaker of the evening was Hon. Frank R. Gusweiler, who gave an interesting talk on the proposed rapid transit loop in Cincinnati. On motion of Mr. Hunter the club endorsed the rapid transit movement and a rising vote of thanks was given the speaker.

The election committee reported the following candidates as being elected: Theo. Luth, Howard Cox, H. H. Nelson and W. S. Rulison.

Speeches were made by Messrs. Nelson, Luth and Rulison, promising to give their best efforts to furthering the interests of the club. W. H. Young spoke for Howard Cox, who was absent.

On Tuesday, March 21, the directors of the Carriage Makers' Club, at a special meeting held at the Business Men's Club, elected the following officers for the ensuing year: President, Charles Fisher, Eagle Carriage Co.; First Vice-president, W. S. Cox, Kelly-Springfield Tire Co.; Second Vice-president, G. W. Huston, The Spokesman Publishing Co.; Secretary, C. J. Rennekamp, Monarch Carriage Goods Co.; Treasurer, Emil Hess, Sayers & Scovill.

The new board of governors consists of the following: H. H. Nelson, American Carriage Co.; Theo. Luth, Luth Carriage Co.; W. S. Rulison, W. F. Robertson, Steel and Iron Co.; Howard Cox, Kelly-Springfield Tire Co.; Chas. Fisher, Eagle Carriage Co.; Emil Hess, Sayers & Scovill Co.; George W. Huston, Spokesman Publishing Co.; C. J. Rennekamp, Monarch Carriage Goods Co.

C. B. N. A. Appoints Dealer Committee

H. C. McLear, secretary of the Carriage Builders' National Association, announces that the executive committee of that organization has authorized the appointment of a committee on dealers' associations, instructing President Ebrenz to choose the members of same. This will be the first time that this association has had a committee of that character.

President Ebrenz has appointed the following as members of the committee: P. P. Hunter, American Carriage Co., Cincinnati, O.; W. H. Roninger, Banner Buggy Co., St. Louis, Mo.; H. A. Crawford, Lull Carriage Co., Kalamazoo, Mich.; A. M. Parry, Parry Mfg. Co., Indianapolis, Ind., and C. S. Walker, Kratzer Carriage Co., Des Moines, Iowa.

Concerning the functions of the committee, Secretary McLear says: "It is intended, if possible, for this committee to act as an arbitration committee, dealing with any matters arising between our members and the dealers, or, I hope, between any carriage builder and any dealer

in vehicles. By this plan it is hoped that all differences between them can be settled to the satisfaction of all. I think we are now on a plane that will result in good feeling all around."

Farm Animals Statistics

The statistics will show an increase in mules, and good team harness will be in demand.

The Crop Reporting Board of the Bureau of Crop Estimates of the United States Department of Agriculture makes the following estimates from reports of its correspondents and agents:

	Per cent of Preceding Year	Numbers	Values	
		Total Number	Per head	Aggregate
HORSES				
Jan. 1, 1916..	99.9	21,166,000	\$101.60	\$2,150,468,000
Jan. 1, 1915..	101.1	21,195,000	103.33	2,190,102,000
Jan. 1, 1914..	101.9	20,962,000	109.32	2,291,638,000
Jan. 1, 1913..	100.3	20,567,000	110.77	2,278,222,000
Jan. 1, 1912..	101.1	20,509,000	105.94	2,172,694,000
Jan. 1, 1911..	102.2	20,277,000	111.46	2,259,981,000
Jan. 1, 1910..	*19,833,000	108.03	2,142,524,000
MULES				
Jan. 1, 1916..	101.9	4,565,000	\$113.87	\$519,824,000
Jan. 1, 1915..	100.7	4,479,000	112.36	503,271,000
Jan. 1, 1914..	101.4	4,449,000	123.85	551,017,000
Jan. 1, 1913..	100.6	4,386,000	124.31	545,245,000
Jan. 1, 1912..	100.9	4,362,000	120.51	525,657,000
Jan. 1, 1911..	102.7	4,323,000	125.92	544,359,000
Jan. 1, 1910..	*4,210,000	120.20	506,049,000

*Census report of numbers, April 15, 1910.

In numbers, horses have decreased 29,000; mules increased 86,000. Net increase of both. 57,000.

Possibilities of Alcohol

Howard F. Weiss, director of the United States Forest Products Laboratory, Madison, Wis., has made a report to the federal government stating that the Madison laboratory produced about 35 gallons of grain alcohol from one ton of sawdust at a cost of between 13 and 15 cents per gallon. He stated that a motor car would not go as far on a gallon of alcohol as it would on a gallon of gasoline with the present type of engine, but with alterations and improvements so that the engine would stand a higher explosive compression, the thermal energy of alcohol would equal that of gasoline.

He stated that the lumber cut in this country amounts to 40,000,000,000 feet annually, and using only waste of the saw mills, he estimates that 500,000,000 gallons of alcohol could be manufactured each year.

Wants Truck Tire Sizes Regulated

Edwin Duffy, highway commissioner of New York state, addressing the students in the Columbia University highway engineering course, said that regulations must be passed limiting the weight of trucks with relation to the number of square inches of tire surface in contact with the ground and with relation to the speed at which they travel. If this were not done, he said, it would be impossible to bear the expense of maintaining the roads that have already been built. The truck, he said, was here to stay and provision must be made to use it in the most economical way. All users of the highway, including horse-drawn vehicles, should be regulated, he maintained.

Electric Vehicle Convention

The thirty-ninth annual convention and electrical exhibition of the National Electric Light Association, which will be held in Chicago, May 22 to 26, in the Congress and Auditorium Hotels and Auditorium Theatre, and which will be attended by many thousands of representatives of electricity supply companies throughout the civilized world, will be featured by the three sessions devoted to electric vehicle topics, also the special electric vehicle exhibits which will be a conspicuous part of the electrical exhibition to be held in the Auditorium Theatre.

An electric vehicle program of particular interest to the central stations and the electrical industry in general, has been carefully prepared and from the manuscripts in hand, assurance is given of a highly successful convention.

The first session devoted to electric vehicle interests will take place Wednesday afternoon, May 24, and will include the following program:

Chairman's address by Walter H. Johnson, secretary's report by A. Jackson Marshall, treasurer's report by H. M. Edwards, reports of section activities, and the committee reports as follows:

Report of membership committee, Joseph D. Isreal, chairman.

Report of standardization committee, E. R. Whitney, chairman.

Report of motion picture film committee, Carl H. Reed, chairman.

Report of traffic and good roads committee, A. H. Manwaring, chairman.

Report of insurance committee, Day Baker, chairman.
Appointment of nominating committee.

The Thursday morning session will be devoted to the following program:

Report of garage and rates committee, George B. Foster, chairman.

Report of legislation committee, P. D. Wagoner, chairman.

Report of federal and municipal transportation committee, J. H. McGraw, chairman.

"Industrial Truck Applications," by C. W. Squires, Jr., sales manager General Vehicle Co., Long Island City, N. Y.

"Electric Truck Troubles and How to Eliminate Them," by F. E. Whitney, general manager, Commercial Truck Co. of America, 27th and Brown streets, Philadelphia, Pa.

"The Relation of Tires to Electric Vehicle Efficiency," by S. V. Norton, manager truck tire sales department B. F. Goodrich Co., Akron, O.

"Greater Garage Service," by Harry Salvat, proprietor Fashion Auto Garage, 51st street and Cottage Grove avenue, Chicago, Ill.

The program for the last session, Thursday afternoon, is as follows:

Report of operating records committee. W. P. Kennedy, chairman.

Report of central station cooperation committee, E. S. Mansfield, chairman.

"Exchange Battery Systems," by P. D. Wagoner, president General Vehicle Co., Long Island City, N. Y.

"Passenger Vehicle Problems and Activities," by E. P. Chalfant, eastern representative Anderson Electric Car Co., 2 Columbus Circle, New York City.

"Central Station Assistance in Promoting Electric Ve-

hicle Use," by W. P. Kennedy, consulting transportation engineer, 1790 Broadway, New York City.

Report of nominating committee.

Coincident with the convention there will be an extremely interesting electrical exhibition in the Auditorium Theatre at which will be displayed electric vehicles of all types, both passenger and commercial, and accessories, batteries, charging apparatus, etc. The National Electric Light Association with whom the Electric Vehicle Association of America affiliated recently, will lend their valuable cooperation in every way possible toward the exploitation of electric vehicles.

It is anticipated that several thousand central stations (electricity supply companies) representatives, including executive, will attend the convention, and it is believed that the exhibit will afford the manufacturers of electric vehicles an unprecedented opportunity to acquaint influential central station interests with the merits of the electric vehicle.

The floor plan, giving all details in connection with the exhibits, shows some 53 booths of unusual proportions, with an aggregate floor area of 10,550 sq. ft. of space for exhibit purposes. Manufacturers will begin installing their exhibits May 22 at 8 o'clock a. m., all work and details of the display being entirely completed by 8 a. m. the following day. Other details and floor plans may be obtained from the Electric Vehicle Section of the National Electric Light Association.

Night Work Lowers Efficiency

That workmen in factories on night shifts are 40 per cent less efficient than those working on day shifts is the conclusion of George D. Babcock, production manager of the H. H. Franklin Mfg. Co., Syracuse, N. Y. Mr. Babcock, after studying the efficiency of night factory forces, concludes that even with greatly increased supervision per man and with special incentives for night work, such as 10 cents extra per hour to the night men, it is impossible to get from the night forces more than 75 per cent of the efficiency obtained from the day shift. Mr. Babcock has further discovered that while the output efficiency of night work is much lower, the regularity of workmen is reduced and the amount of rejected work is much greater at night than in the day. This situation is not entirely due to artificial lighting or to less satisfactory shop conditions, but principally to the lack of willingness of first class workmen to work nights, and to an increased fatigue on account of carelessness in the hours of rest and sleep. The daily hours of sleep are not so regular with a person on night work as with one on day work. Mr. Babcock believes that sleeping during the day develops nervousness which tends toward restlessness.

That the efficiency of a workman is not so great at night has been demonstrated at other factories. In one Cleveland factory the test made some years ago showed that the output of a day force dropped off materially when the electric lights were switched on at four o'clock on the winter afternoons. The electric current for the machinery and also for the lights was drawn from the same switch board and it was found that the consumption of current after the lights were turned on was actually a little less than before. This can only be explained by the fact that the men were not working at the same capacity and the different machines were considerably below their average output.

Light on Rim Situation

There is a general feeling of relief throughout the automobile manufacturing field, writes F. E. Spooner, in the Detroit Free Press, of August 16, due to adjustments which are being made in the field of rims, the rim situation having been one of the most trying through which the automobile manufacturers have had to pass in many years.

The rim manufacturers, immediately after the outbreak of the Perlman patents matter, took steps to find rims which would take the place of those using the wedge and upon which Mr. Perlman's patents were based. The Standard Welding Co., which provides about 70 per cent of the rims of the industry, found ways in which to provide the manufacturers with a rim which would not infringe. Two other companies, the Jackson Rim Co., of Jackson, Mich., and the Mott Wheel Works, of Utica, N. Y., formed an alliance with the Perlman Rim Corporation, and the Kelsey Wheel Co., of Detroit, found that it had in its possession rim patents enabling it to assure all of its customers satisfactory rims to replace the wedge rims.

One large manufacturer succeeded in saving itself by closing an arrangement with the Perlman Rim Corporation by which it pays a royalty and at the same time pays to the Standard Welding Co. the contract price for rims.

With the arrangement with the Standard Welding Co., it is stated, no agreement was reached between the Perlman Rim Corporation and the Standard Welding Co. with regard to back royalties. It seems not improbable that several other companies will make a like arrangement through which they will be able to secure the manufacture of rims by the Standard company with which to clear their product for the year.

In the meantime the Perlman Rim Corporation is assuring all of the manufacturers that with its present and other facilities which will be added immediately it will be able to take care of all demands.

The report that the Perlman corporation had secured two factories in Detroit does not seem to be borne out by facts and in refutation of this the statement is made by a well known Detroit manufacturer that the rim company has no factory under contract in the city of Detroit.

Japan Making Its Own Motor Cars

Increased manufacture of motor cars in Japan is indicated by the import figures for 1915 compared with those of 1914, as reported by the Japan Daily Mail. The total from foreign sources in 1915 was 26 cars valued at \$30,595, while in the preceding year the imports were 79 cars valued at \$106,420. The newspaper says the native cars are now well made and are produced at low prices, thus affecting the imports of higher priced foreign cars.

The sources of the cars imported in 1915 were: Great Britain, 4 machines, valued at \$8,721; United States, 10, valued at \$15,798; other countries, 12, valued at \$6,076. For 1914 the figures were: Great Britain, 17 cars, valued at \$30,356; United States, 33, at \$28,787; other countries, 29, at \$47,277.

A firm owning a taxicab service in Tokyo is now operating 42 cars from 9 stands, averages 700 passengers daily, and all of the cars are of American make and were furnished by an American firm in Japan. The company started August 15, 1912, with 6 machines. It now employs 65 persons and its chauffeurs work in three shifts,

affording all-night service for patrons. Each car covers an average of 60 miles a day. The firm has also undertaken the extension of a motor-bus service in Chosen, and the prospects there are reported to be promising.

New Patent Order Made by Canada

An Order in Council of the Canadian Government, dated February 14, 1916, has been issued based on the War Measures Act, 1914, and modifying the orders and regulations of October 2, 1914. The changes are important in that they provide for the grant of a second or subsequent extension for doing any act or filing any document required under the Canadian statute, and in a new and important section provision is made (on proper application to the Commission) for relieving patentees from the obligation to work their inventions in Canada during the period of the war, and also for permitting extensions for importing into Canada the subject matter of the patent, without prejudicing the same. The new section of the orders and regulations reads as follows:

"10. In any case in which through circumstances arising from the present state of war, the Commissioner may deem it expedient, he may order that during the continuance of the war and for six months thereafter, neither the failure to construct or manufacture in Canada any patented invention nor the importation of such invention into Canada shall in any way affect the validity of the patent granted in respect of such invention, notwithstanding anything in the Patent Act or in such patent.

Increased Demand for Motor Vehicles and Accessories

There was a marked increase in the sales of motor cars and motor trucks of American manufacture writes Consul Fleming from Edinburg, Sctoland. The British customs duty of 33 1/3 per cent imposed in September on pleasure cars had little effect on the trade. Compared with English prices the American cars were still good value. The demand for motor trucks was strong throughout the year, but business was affected by the abnormal shipping and labor conditions which caused delay in getting the goods transported. American manufacturers, however, again demonstrated the fact that in moderate-priced cars they are far ahead of any of their competitors and that they can retain the good market that has been created.

The accessories trade was exceptionally active, the principal feature being a great demand for tires. Sales of American tires, car and motorcycle lamps, horns, generators, magnetos, bolts and nuts, copper and asbestos washers, etc., were large and at greatly increased prices.

Half Million War Horses Shipped

Records of exports show that more than 500,000 horses, valued at \$125,000,000, have been shipped from the United States to Europe since the beginning of the war. A compilation made by the foreign trade department of the National City Bank states that in the last five months of 1914, 50,000 were shipped, and in 1915 approximately 440,000.

Prices have tended to decline. Against an average price of \$240 per head in 1914, they were selling at \$207 last November, the last month in which reports from all parts of the country were received.

How to Rim a Heavy Wheel

To rim or "ring-up" a heavy cart wheel, presuming the spokes are already tanged, first prepare a felloe pattern of $\frac{1}{2}$ -in. board, giving it a little less compass than the true arc of the wheel, as determined by the following rule: For every foot the wheel is in height add $\frac{1}{4}$ in. to the diameter of the circle for the pattern up to 3 ft., and from that height to 5 ft. 6 in. add $\frac{3}{8}$ in. per foot. Procure the felloes ready sawn out to as near the required size and sweep as possible, face them on one side, correcting any winding there may be, and gauge and dress to thickness. Then mark out to pattern and dress the belly to the line, leaving the sole a little full. The length of the felloe is generally obtained by placing it over three spokes close up to the shoulders, and marking it at the center of the two outer spokes; or the length can be obtained by multiplying the diameter of the wheel by 3.1416, and dividing by the number of felloes, setting off the length obtained with the tape on the sole of the felloe. To mark the ends of the felloes, set a bevel so that when the stock is held to the belly or inside with the blade across the face, and then reversed, the blade coincides with the former position as shown by Fig. 1. Mark

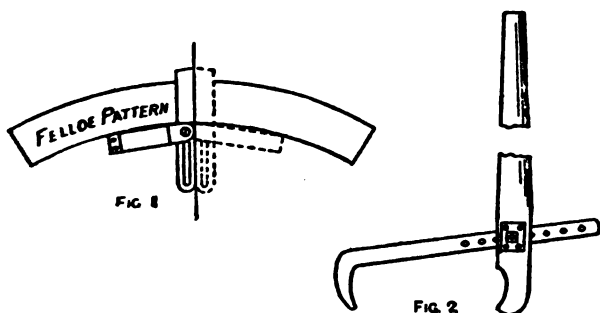

and saw off the ends of the first felloe to the bevel obtained, and square across the other way. Lay the wheel face downward on the wheel stool, place the felloe on the tangs of two spokes close to the shoulders, the ends projecting equally between the adjacent spokes, and mark the center of the spokes on the belly, also both sides of the tangs on the face. Mark the felloe and spokes so that its place can be found again after being taken off. Square lines across the belly through the marks indicating the center of the tangs, and gauge across these lines from the face for the center of the holes. Bore the tang holes with a twist auger, using the lines on the face of the felloe as a guide to get them radial. Spring the spokes together and knock the felloe on close up to the shoulders. Fig. 2 illustrates a useful lever for springing spokes. Take the next felloe, cut it to length, dressing the ends to the bevel, place it on the ends of the spokes with the left end close to the first felloe, and mark the position of the tangs as before.

Having fitted the second felloe, drive out the right end a little until the joint between the two is parallel, then "cut in" the joint by running a saw through. Knock the felloe up close to the shoulders of the spokes again, and proceed with the others in the same way, working from left to right, and numbering them in succession so that they can be put on in their respective places again after being taken off. When cutting in the last felloe joint, leave it $\frac{1}{8}$ in. open on the sole. Knock the felloes off, and with the adze take a shaving out of the ends to ensure

them coming up close all round the edge. Bore the dowel holes in the ends of the felloes, $\frac{3}{16}$ in. from the center toward the sole and $2\frac{3}{4}$ in. deep for a 5-in. dowel, using a twist bit. With the same bit, bore a hole through a piece of 1-in. hardwood, and drive the dowels tightly through it to ensure a good fit. Arrange all the felloes the same way up close together on the bench, and drive a dowel in one end of each. Replace the felloes on the ends of the spokes with the dowels entering the holes bored for them, and knock them up all round a little at a time until snug at the shoulders. Then pare a little off the ends of the tangs, split them crosswise of the rim with a chisel, and wedge them up. Cut off the ends of the wedges and trim the face of the wheel up, using a straight-edge for the purpose. Dress the sole of the rim square all round, and gauge the width of the tire $\frac{1}{8}$ in. from the face. Dress to the lines with the draw-knife and spokeshave, and round-in with the file and the liberal use of glass-paper.—R. H. Lomas, in Work.

German Tanners Hard Pressed for Materials

According to Der Ledermarkt the German tanners are anxiously looking forward for the maximum prices for tanning materials, to be fixed by the government. Some of the tanners claim that the situation has become almost unbearable; not only that prices of tanning materials are so high at present, but sometimes it is hardly possible to secure sufficient quantities of barks or extracts to keep the tanneries going. It is impossible to buy any oak bark under 20 marks per cwt. today. Before the war this price would have been considered as simply ridiculous, but today it is gladly paid. Leather manufacturers trust that by fixing the maximum prices an end will be made to the speculation in barks. There are many speculators, who have taken large quantities of this valuable tanning material off the market, keeping them back, expecting to realize considerable higher prices shortly. Up to the present this speculation has worked splendidly.

The demand for chestnut is very strong. There is only one district in Germany, Alsace-Lorraine, where chestnut is produced. The production is insufficient to cover the extensive wants of the German tanneries on chestnut, however; hence the very high prices paid for chestnut extract. Extract factories are compelled to run day and night to cover all the orders received.

Metric System Bill Provides \$500 Fine or Jail

A bill for the compulsory use of the metric system has been introduced in Congress. According to the bill, after July 1, 1924, all Americans may have the choice of breaking the law or of using the metric system; any person, corporation, company, society, or association who shall use, or offer and attempt to use, in any industrial or commercial transaction in the sale or purchase of any commodity any other weights and measures than those of the metric system shall be guilty of a misdemeanor, and upon conviction thereof in any court shall be punished by a fine of not more than \$500 or by imprisonment for not more than three months, or by both such fine and imprisonment. Frederick A. Halsey, who led the fight against the metric system a decade ago, is again leading the opposition to the measure, which is known as the Dillon bill.

C. B. N. A. Membership Campaign

The membership committee of the Carriage Builders' National Association is making a special effort to obtain an application for membership from every eligible manufacturer who is not already on the roll. To this end the following letter has been sent to all such manufacturers:

Dear Sir—Your standing as a carriage builder prompts us to ask for your cooperation. We want the help of your advice and suggestions to make the buggy business larger, and therefore solicit your membership in our association.

Do you know what the Carriage Builders' National Association is doing for the horse-drawn vehicle business? The executive committee, selected from 141 of your fellow craftsmen and 266 of the accessory trades, has inaugurated a publicity campaign to boost the buggy business and keep the horse-drawn vehicle before the people.

Eighteen hundred dollars has been appropriated from the association funds and more than \$1,000 additional is guaranteed by several of the larger buggy manufacturers, all of which is being used to propagate the buggy business.

You are getting the benefit derived from articles published in hundreds of country newspapers concerning the buggy and horse.

The buggy business is all right if we make it so. Mix with us at convention time. Rub elbows with the boosters and get new ideas and enthusiasm. It will pay you.

Become a booster now. Sign the enclosed membership blank and mail today.

Hurry Call for Army Trucks

When the United States troops were ordered to Mexico bids were asked by telegraph on 54 1½-ton trucks to be sent with them as supply and baggage carriers. Orders were placed in two days with the White Company, of Cleveland, O., and the Thomas B. Jeffery Co., of Kenosha, Wis., for train loads of trucks, which were put under way almost instantly for the border in special trains which had the right of way over other traffic.

In addition to the 54 carrying trucks, two traveling repair shops were required, fitted with small lathes, drill presses, forges, bench vises and supplies of repair parts. In addition to this 15 motorcycles were ordered for use of corporals and messengers.

Civilian mechanics who were hired to go with the fleet were one truck master at \$150 a month, three assistant truck masters at \$125 a month; one mechanic at \$125, one assistant mechanic at \$100, and 27 drivers at \$100 each for each company. The regulation United States army truck body was used.

The Los Angeles Motor Reserve Corps of the California National Guard, which rapidly increased its membership as soon as the difficulty on the Mexican border broke out, was ordered to active duty March 15 for any service that might be necessary.

Condition of Buggy Trade

The publicity bureau of the Carriage Builders' National Association sends the following story relating to the buggy trade outlook:

Reports from manufacturers and dealers respecting the present demand for buggies and the prospects for future business vary quite a little according to the localities from

which we receive them. This statement came from an official of the Carriage Builders' National Association. In some central and western states reports are of a very cheering character, not only as regards the amount of business already transacted, but also in reference to the immediate outlook.

A great many dealers state that their business has far exceeded their expectations, and that numbers of second orders have been necessitated by the clearing up of their first lots. In other cases dealers tell us that their trade so far this year has been about normal—no variation being noticeable, one way or the other.

As a matter of fact, there are undoubted signs of a considerable improvement in the horse-drawn vehicle business, and the preponderance of favorable reports over those of the opposite character is easily five to one.

"The demand for shafts and poles for horse-drawn vehicles has not been materially affected in the past five years," says an Ohio member of the association, who has exceptional opportunities for gathering information on the subject.

Great Additions to Steel Capacity

Tremendous expansion is under way in the steel industry which will increase the capacity of the country to produce steel by millions of tons by the end of another year. Open hearth steel mills with a rated capacity of 4,300,000 tons are under way and construction is being rushed day and night upon them. The United States Steel Corporation has 18 open hearth plants with a rated capacity of 1,500,000 tons already under construction. The independent steel companies have 73 open hearth plants planned or under construction, which will produce 2,700,000 tons of steel annually when completed. These plants will enable the independents to produce fully as much steel as the United States Steel Corporation.

It is probable that the first of these plants to be put in operation will be completed late in the summer or early in the fall, and it will be 1917 before the country can get the benefit of all of them. As it is now delivery cannot be guaranteed by any of the mills inside of from six to nine months. From inquiries that are made, some of which are not followed by orders because of the conditions in the trade, it is evident that vast quantities of additional steel could be sold for both home and export consumption if it could be made. At present, for the first time in its history, the United States is producing more steel than all the rest of the world put together.

Personal

Harry E. Bruce has resigned his position as traffic manager of the Troy (O.) Wagon Works, after being connected with that company 13 years, and accepted a position in the Cincinnati branch of the Blevins Auto Sales Co. of Toledo. He will act as cashier and local financial officer.

Large Force at Work

The Abingdon (Ill.) Wagon Co. are enjoying a very prosperous business. They have a large force at work, filling the orders coming in daily. The company has serious trouble in getting steel and iron on account of the war in Europe.

Trade News From Near and Far

Business Changes

It is reported that G. W. Eckert, Nevada, O., will close out his line of vehicles.

Clarence Twito succeeds N. E. Jordan in the vehicle and harness business at Northwood, Ia.

Keller & Farmer succeed Carlson & Keller in the implement and vehicle business at Humeston, Ia.

N. T. Crawford & Sons have disposed of their implement, vehicle and harness business at Morrisville, Mo., to A. R. Harmona.

George M. McClain, of Okolona, Ky., has sold his vehicle and general business to L. R. Helm and J. S. Long. Mr. McClain has opened a new store at Lyndon, Ky., in which he will handle similar lines.

Creamer Bros., late of Academy, S. D., have purchased the implement and vehicle business of W. A. Thwing & Son, of Bijou Hills. The sale also included a hardware line. The new owners have added a full line of automobiles and supplies.

The vehicle house of Thorn & Gwin, of New Albany, Ind., has been reorganized as L. Thorn & Sons; W. D. Gwin having sold his interest in the concern to Lewis Thorn some time ago. Herbert Thorn is in the business with his father, and one of the other two boys may enter shortly.

New Firms and Incorporations

Henry Gilsinger has engaged in the vehicle business at Buffalo, Ind.

W. E. Birmingham has engaged in the implement and vehicle business at Kenton, Tenn.

Hawk & Stansberry will engage in business at Iantha, Mo., handling a line of implements and vehicles.

Neil & Harrison will erect a new building at Kingsport, Tenn., and put in a line of implements, hardware and vehicles.

Dimmick Bros. have rented a building at Williamsfield, Ill., and are putting in a stock of implements, vehicles and automobiles.

Wm. and J. L. Hoepfner are erecting a building at Wadena, Minn., preparatory to engaging in the vehicle and implement business.

Landess & Howse have engaged in business at Whiteville, Tenn., for the purpose of handling a line of implements, vehicles, hardware, etc.

The Columbia Cooperative Co. has been incorporated at Columbia, S. C., with a capital stock of \$5,000. The company will handle implements and vehicles.

The Futhy Lumber & Hardware Co. has been organized at Shadyside, O., with a capital stock of \$35,000, for the purpose of handling vehicles, implements, lumber, etc.

The Eufaula Hardware Co. has been organized and incorporated at Eufaula, Ala., for the purpose of conduct-

ing a wholesale and retail business in vehicles, implements, hardware, etc.

Harley Baker and John Daum have engaged in the implement and vehicle business at Marysville, O. Both are well known in the community, and Mr. Daum has been engaged in the business for many years.

The Central Wagon & Auto Co., of Cleveland, O., has been incorporated with a capital of \$75,000, to manufacture and sell wagons and automobiles. The incorporators are H. D. Squires, G. E. Bradbury, C. E. Mellon, H. A. Beckett and L. C. Spieth.

Doings of Motor Truck Builders

E. Van Winkle, of Chattanooga, Tenn., is planning to establish a plant at Chattanooga, for the manufacture of parts and assembling motor trucks.

The Covert Gear Co. has been incorporated with a capital of \$1,000,000, to manufacture trucks, tractors and other vehicles, at Lockport, N. Y. The incorporators are W. W. Armstrong, P. A. Clum, B. V. Covert.

During the first half of March the sales of the United Motor Truck Co., Grand Rapids, Mich., were 50 per cent in excess of the sales of the month of February, which was itself 119 per cent better than January.

The Gerlinger Motor Co., Portland, Ore., capitalized at \$100,000, will construct a factory in Tacoma, Wash., to manufacture the Ger-Six motor truck, designed by George Peters, chief engineer of the company.

Orders for trucks to the value of \$1,000,529.75 are on the books of the Packard Motor Car Co., the results of its domestic truck business for March. More than 99 per cent of the amount was for truck chassis; a majority of the buyers ordered bodies built by outside concerns.

The Republic Motor Truck Co. will erect an addition, 60 x 500 ft., to its plant, at Alma, Mich., thus increasing the total floor space by 30,000 sq. ft. The working force, which is now about 700 men, will be greatly increased, as will production, which is now at the rate of 30 trucks a day.

At a meeting of the board of directors of the Chase Motor Truck Co., of Syracuse, N. Y., held on April 7, a report was submitted by General Sales Manager H. T. Boulden, showing that up to April 1 the Chase company had on its books, and unfilled, orders amounting to \$301,414.04, represented by business for domestic shipment.

The Thomas Auto Truck Co. has been formed to build trucks in New York City at 639-641 West 51st street. The line will consist of a $\frac{3}{4}$, 1, 1½ and 2-ton chassis, and complete bodies and also a line of taxicabs. C. K. Thomas, president and founder, was for three years previous vice-president and general manager of the Federal Motor Truck Co., of New York.

The Lewis-Hall Iron Works, Detroit, Mich., is now producing four models of commercial vehicles as follows:

Two-ton, worm drive chassis, \$2,000; 3½ ton, double side chain chassis, \$2,800; 3½-ton, worm drive chassis, \$2,800; 5-ton double side chain chassis, \$3,400. The company has appointed Kuehn & Metz, 1926 Broadway, its New York representative, and plans to locate distributing agencies on the Pacific coast.

The Cyde Motor Truck Co., which was incorporated in Delaware with a capital of \$750,000, has acquired a plant in the automobile district of Long Island City, near Woodside. It is expected that deliveries on its one-ton truck, selling at \$1,000, will begin in July. The purpose of the company is to assemble this truck exclusively. It is equipped with a Buda engine. M. C. Swartz, a real estate operator, is president of the company; W. F. Melhuish, formerly of the White Motor Co., is vice-president; J. F. Mason is secretary, and E. E. Vreeland, an advertising man, is treasurer.

The Vim Motor Truck Co., Philadelphia, Pa., has added a mail delivery car to its line of seven standard units. The new vehicle is called the model M and sells for \$800. Some time ago the Vim company received an order from the United States government for a mail carrier to be built according to strict specifications, and the demand which sprang up for these cars resulted in the adoption of model M as a regular model. The body has full screens all around, with doors at front and rear. There is a passenger step at the back for the use of the mail carrier and other equipment is up to government specifications. The body, which is mounted on the standard Vim four-cylinder chassis, is designed especially to meet the requirements of post offices, mail contractors, rural free delivery routes, etc.

The Day-Elder Motors Co., Newark, N. J., has been formed to manufacture motor trucks. The plant is located at 161-167 Ogden street. A 1-ton and a ½-ton model will be manufactured, the tonner selling around \$1,400 and the other model at \$850. These prices are at present only tentative. The 1-ton truck will be equipped with a Continental four-cylinder motor developing 19½ h.p. Other features are Bush radiator, Detroit Gear & Machine Co. transmission, and Sheldon front axle and springs. The ½-tonner will use a Le Roi motor, developing 16 h.p. Other features are a Grant-Lees transmission, Sheldon worm-drive rear axle, and Sheldon front axle and springs. This model will also be equipped with a starter. Chas. F. Day is president of the company, and G. A. Gemmer, the inventor of the Gemmer steering gear and who assisted in the organization of the Gemmer Mfg. Co., Detroit, is vice-president.

Among the Tire Makers

The Marion (O.) Tire & Rubber Co. is planning to build a plant. The estimated cost is \$20,000.

The Goodyear Tire & Rubber Co., Akron, O., will erect a five-story 68 x 142 ft. addition to its general office. The structure will cost about \$48,000.

The Victor Rubber Co., Springfield, O., maker of pneumatic tires, has had plans prepared for additions to its plant that will nearly double its capacity.

The Toledo-Findlay Tire & Rubber Co., Findlay, O., capital \$300,000, has been placed in the hands of a receiver upon the application of A. O. Hamilton, Charles Reick, V. T. Spittler and Henry Ward, directors.

The Acme Tire & Rubber Co., Ltd., Toronto, has been incorporated with a capital stock of \$400,000, by Joseph M. Bullen, Francis H. Hurley, Harold L. Steele, and others, of Toronto, to manufacture tires, rubber goods, etc.

The K. & S. Canadian Tire Co., Ltd., which introduced the Kelly-Springfield tire into Canada, is now manufacturing at its Guelph, Ont., factory K. & S. tires, which are guaranteed for 7,000 miles on Ford cars and 6,000 miles on other cars.

The Union Tire & Rubber Co., recently incorporated in Delaware with a capital of \$500,000 to manufacture automobile tires, has acquired the former plant of the Banner Rubber Co., at Kenrick and Bittner streets, St. Louis. The plant has a frontage of 252 feet on Kenrick street.

The newly elected board of directors of the United States Rubber Co. met in New York City, March 23, and elected the following officers: President, S. P. Colt; vice-presidents, J. B. Ford and Lester Leland; vice-president in charge of development work, R. B. Price; vice-president in charge of mechanical department, E. S. Williams; assistant to president, J. N. Gunn; secretary, Samuel Norris; assistant secretary, J. D. Carberry; treasurer, W. G. Parsons; assistant treasurer, E. J. Hathorne.

The J. & D. Tire & Rubber Co. has been organized at Charlotte, N. C., for the manufacture of pneumatic tires for automobiles. The president of the organization is Harold O. Smith, who started in the rubber business in 1893 as one of the founders of the Indianapolis Rubber Co., which concern later became the G. & J. Tire Co. of Indianapolis, of which Mr. Smith was president. Mr. Smith was in the tire business approximately 13 years until 1906, when he formed the Premier Motor Car Co. of Indianapolis, of which he was president until a year ago.

Body Building Briefs

The Ideal Auto Body and Seat Co., Inc., has been organized in Buffalo, N. Y.

A. D. Moore and Mr. Shaw, Palmer, Mass., have leased the vacant belt factory in Belchertown, Mass., and will make automobile truck bodies.

The Miller Automobile Body Co. has been organized at Wichita, Kas., by G. A. Miller and Geo. A. Holtzman, the latter an expert limousine and automobile body designer and maker.

The Badger Auto Body Co., Milwaukee, has been incorporated with a capital stock of \$10,000 by H. J. Trost, T. F. Hayden and B. Beebe, to manufacture metal and wood automobile bodies.

The Dayton (O.) Body Co. has been formed with \$100,000 capital to manufacture automobile bodies. A factory will be constructed, 64 x 384 ft., four stories, of brick. J. D. Art is general manager.

Ionia, Mich., will have a new automobile body plant in the spring. Work has been started on the two large buildings which will be located north of the Hayes-Ionia plant. H. B. Webber is president and George W. Webber secretary of the new company. Harry Bill, Hal Smith and H. J. Hayes are stockholders. The plant will make wood parts for autos.

The Fleetwood (Pa.) Metal Body Co. is preparing to occupy its new building along the P. & R. Railroad. The building is an addition to the present three-story plant and contains 80,000 sq. ft. of floor space. Its dimensions are 40 x 350 ft., with connecting wings 40 x 80 ft. and 110 x 50 ft. It is equipped with modern machinery and methods for the manufacture of automobile bodies.

Emil Haberer and several associates are about to start a factory for the manufacture of commercial bodies in Cincinnati. It is reported that the new corporation, likely to be known as the Specialty Mfg. Co., has practically closed a deal for a long lease of the major portion of the former plant of the Union Distilling Co., 1153 and 1169 Gest street, the holding containing more than an acre of buildings of two, three and four stories.

The Keystone Vehicle Co. has leased a building at Fourth and Goodale streets, Columbus, O. This company was incorporated in 1914 for \$15,000. The company will increase its capitalization now to \$25,000. Hearse, ambulance and limousine bodies form the basis of their product, and the company has been turning away business for the past six months. The officers are C. H. Myers, president; E. L. Hoffman, vice-president; Howard E. Sullivan, secretary-treasurer and general manager.

J. W. Henney, Jr., Freeport, Ill., has leased the Bloom Building, Hancock avenue, East Freeport, and commenced the manufacture of hearse bodies for automobiles. He has for his associates several Chicago men who are well versed in body making for motors. Mr. Henney recently resigned his position with the Staver Mfg. Co., Chicago, to take charge of the Freeport plant. He was for many years superintendent of the Henney branch of the Moline Plow Co. The new plant opened for business April 1.

The Stover Steel Tank Co., Freeport, Ill., has embarked upon a new side line, building all-steel bodies for commercial motor vehicles, no wood whatsoever being used in the construction. The Ford commercial all-steel body is made entirely from one piece of steel, with the exception of the hinged end-gate, and, under this form of construction, the makers entirely eliminate metallic sounds from riveted joints. In addition, the company is making all-steel express and stake bodies, ranging from the smallest to the five-ton trucks.

Contract to build an extension, 100 feet long, on the east side of the factory, has been awarded by the Wright Carriage Body Co., Moline, Ill. Approximate cost of the improvement will be \$10,000. The addition is to be three stories, to conform with the present structure. Work will be started at once. "Enlarging of the plant is made necessary by the increased production, declared E. H. Wilson, secretary. "We are doing a great deal more automobile work, and this, in addition to our carriage business, makes it necessary to add more floor space. Dimensions of the Wright building, with the addition, will be 70 x 350 feet."

General News of the Vehicle Trade

C. T. Myers has been appointed manager of the Timken-David Brown Co., manufacturer of worm gearing, Detroit, Mich.

J. L. Milner, Grenada, Miss., will equip a wood-working

plant at Batesville, Ark., to manufacture wagon accessories, automobile rims, etc.

The Briscoe Motor Corporation has leased the plant of the Fuller Buggy Co., at Jackson, Mich., and will probably use it as its final assembly plant.

It is reported that the Maxwell Motor Car Co., Dayton, O., is having plans prepared for an addition to its plant. It recently installed a large lot of equipment.

The Studebaker Corporation, New York City, will install about \$50,000 worth of machinery in the building it will erect at Dallas for an automobile assembling plant.

A. J. Colt, general manager of the Turnbull Wagon Co., Defiance, O., for the past two years, has been elected president as well as general manager. The business of the company has been greatly increased under his direction.

The Hupp Motor Car Corporation has been granted permission to carry on a manufacturing business in Ontario with a capital stock of \$100,000, to manufacture automobiles, etc., and has appointed Edmund A. Cleary, Windsor, Ont., its attorney.

"We have no kick coming about business," said E. J. Knapp, of the Hickory Carriage Co., Cincinnati, O., when asked how the coming season's buggy business looked to him. "We have all we can do, and are expecting one of the biggest years for our company."

The House Wheel Co., Buffalo, capitalized at \$2,000,000 by Henry A. House, Jr., Mitchel H. Mark and Eugene L. Falk, will at once establish and equip a factory in leased premises to manufacture wire wheels for automobiles. Later it will acquire a site in Buffalo and erect a plant.

Exports of Harness, Saddlery, etc.

The swift pace in exports in December, 1914, was not kept up in December, 1915; but for twelve months ending December, 1915, exports of harness and saddlery were \$18,237,507, compared with \$3,478,248 in 1914, and \$751,426 in 1913.

Exports of "all other" embrace a variety of leather in different forms, and it is significant that shipments abroad for 12 months ending December, 1915, were \$18,254,761; \$2,378,218 in 1914, and \$1,993,486 in 1913.

Bimel Spoke and Wheel Factory Enlarges

The Bimel Spoke and Wheel Co., Portland, Ind., is extending its plant by the addition of six large kilns for the final seasoning of spokes and felloes. This will provide sufficient capacity for a daily production of 400 sets of pleasure car wheels and 50 to 100 sets of truck wheels.

Exports to South America

The United States sold merchandise worth \$97,396,826 to South America during the last seven months of 1915, as compared with sales amounting to \$53,033,940 during the corresponding months of 1910.

Output of U. S. Factories

The output of manufactured articles in the United States has more than doubled since 1900.

To Prevent Confusion in Testing of Tires

Because of confusion in interpreting the results of tests of automobile tire fabrics in the mills the United States Bureau of Standards has made a study of the various methods employed and has assisted the fabric and tire makers in developing those best suited to produce accurate and reliable results. The conclusions reached have been published in Technologic Paper No. 68 of that bureau.

This work was undertaken with the view to standardizing the more important methods of tests made upon 17¼ ounce cotton tire fabric. The chief causes of variation in test results were found to be differences in testing machines, size of test specimen, moisture in fabric at time of test, method of selecting samples, and in the fabric.

Interested persons may obtain copies of the publication, which is entitled "Standardization of Automobile Tire Fabric Testing," without charge, upon request to the Bureau of Standards, Washington, D. C.

Invents New Type of Automobile

Arthur Beijer, of Stevens Point, Wis., is the inventor and is now engaged in building a new type of automobile, which it is expected will be completed within 60 days. It is known as the Beijer hydraulic automobile, and works differently from anything now on the market.

The new automobile will be a 50 horsepower touring car and will be distinguished by a new form of transmission which operates on the same principle as the hydraulic jack. A three-cylinder rotating pump is placed on the flywheel of the engine and pumps columns of oil through pipes to motors, one of which is located on each wheel of the car, front as well as rear. Thus a form of rear wheel drive is attained. This new device replaces clutch, transmission, universal joints, differentials, brakes and all gears now in general use.

Car Tax in England Trebled

A treble tax has been placed on all British automobiles, ranging from \$21 to \$630, according to horsepower. This, it is thought, will not only kill pleasure riding, but will go a long way toward crippling the industry.

The new scale doubles the tax on automobiles of 16 h.p. or less and trebles that on cars of more than 16 h.p. The new tax will hit the American cheap automobiles more than British cars, as virtually all of the American-made cars come within the category of more than 16 h.p. The tax will probably mean a big drop in the price of second-hand automobiles.

The taxes on automobiles in Great Britain last year were as follows: 6½ h.p., \$10.80; 12 h.p., \$15.75; 16 h.p., \$21; 26 h.p., \$31.50; 33 h.p., \$42; 40 h.p., \$52.50; 60 h.p., \$105, and exceeding 60 h.p., \$210.

Output of 75,000 Trucks This Year

An output of 75,000 trucks for the coming year is predicted by authorities who are capable of judging accurately the probable production of the truck factories. There are now more than 100,000 trucks in use in the country. At the beginning of 1912 there were about 20,000 trucks in service. American makers are all working overtime—some of them night and day—and are

entirely unable to fill their orders. It is probable that if all war orders were withdrawn at once they would be able to work at full capacity on domestic business.

Location of Officials of Tanners' Association

President H. Frederick Lesh, of the National Association of Tanners, announces that their eastern office is now established at 146 Summer street, Boston, and is in charge of Cudworth Beye, executive secretary.

The Chicago office (212 West Washington street) is in charge of A. G. Reid, assistant secretary. He will conduct the group activities and meetings of the middle west and co-operate with the eastern office of the association.

General Secretary Harry I. Thayer has his headquarters in Boston, same as President Lesh.

Auto Company Files Schedule

Following the order for the adjudication of the affairs of the Great Western Automobile Co., of Peru, Ind., by Judge Anderson, in federal court, a schedule of assets and liabilities was filed April 10. The liabilities are placed at \$71,815 and the assets at \$68,123. Several creditors of the company filed a petition in which it was asked that a receiver be appointed for the plant on the contention that it already had committed an act of bankruptcy and that it was insolvent. This petition was followed by the court's order for adjudication.

Will Issue Bonds

Stockholders of the Kentucky Wagon Mfg. Co. have voted favorably on the proposal to issue \$500,000 of bonds with which to take up all the obligations outstanding of the company and retire a previous issue of some years ago, which was never sold. This will put the company in excellent shape and supply the funds necessary for some important extensions of the plant, which are proposed and needed. Sales of the Old Hickory motor truck continue to be satisfactory, as do sales of the other lines.

Will Represent Turnbull Wagon Co.

W. A. Newhauser, formerly with the Staver Carriage Co. and Harber Bros., has been engaged to represent the Turnbull Wagon Co. in eastern and central Illinois. He will make his headquarters at Normal, Ill. Mr. Newhauser is one of the best men on the road and has a large number of loyal friends with the trade. A square salesman with a standard line such as every knows the Turnbull to be, is sure to succeed.

Albany Hame Buys Rim and Shaft Plant

The plant of the Kentucky Rim and Shaft Co., Louisville, Ky., has been sold at auction and the equipment purchased by the National Hame and Chain Co., of New Albany, Ind., George D. Todd, president. Mr. Todd states that the equipment will be removed to New Albany and consolidated with the plant there.

Now Lead in Manufactured Exports

In exports of manufactured articles, the United States now leads all the world. The total for the year 1915 was \$1,784,000,000, while Great Britain exported only \$1,500,000,000.

O B I T U A R Y

John Hopewell, of the firm of L. C. Chase & Co., 89 Franklin street, Boston, died in Washington, D. C., March 28. Mr. Hopewell, accompanied by his wife and married daughter, were staying in a Washington hotel on their way north from Georgia. Several days prior Mr.

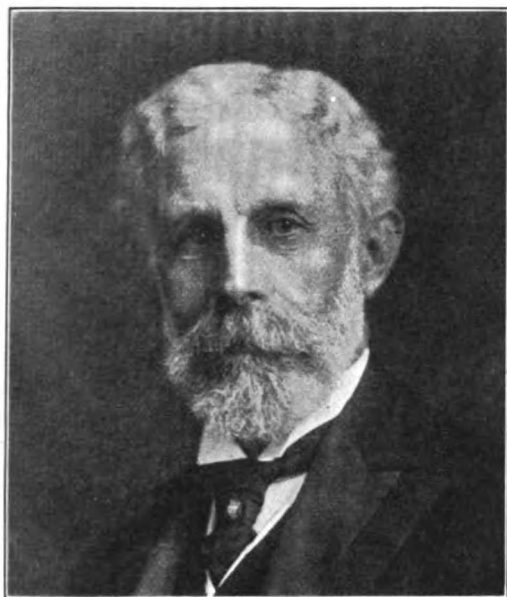

Hopewell had a shock, and the family hoped to be able to bring him home before he grew worse. Mr. Hopewell was born in Greenfield, February 2, 1845. The family moved early to Shelburne Falls, where the son's boyhood days were spent. At the age of 21 Mr. Hopewell went to Springfield and a few years later he located in Boston and associated himself with L. C. Chase & Co. and in five years became a member of the firm. He had been identified with this house ever since. Mr. Hopewell was a director in the First National Bank and several other companies and belonged to a number of social clubs. He resided at Cambridge for 25 years but during the past eight years has been a resident of Newton. In 1890 he was a member of the House of Representatives and six years later he was a delegate to the Republican national convention at St. Louis. He also was a delegate to the National Board of Trade conventions at Washington for four successive years.

Gilbert H. Lounsbery, 86, died March 23 of heart disease. He was the founder of the firm of G. H. Lounsbery & Sons, Cincinnati, importers and jobbers of carriage and automobile upholstery, which business he established 35 years ago, and from which he retired 10 years ago. He was born in the state of New York, but moved to Loveland almost half a century ago. Prior to the founding of his business in Cincinnati, he was a furniture dealer. He is survived by two sons and a daughter.

George Nichols, 86, for many years in the carriage and wagon business near Lancaster, O., died April 12 at the home of his daughter. Three children survive him.

Chas. M. Pearce, 61, lifelong resident of Columbus, O., and for 25 years superintendent of the Columbus Buggy Co., died in that city April 17 after an illness of two years.

He served in the office of sheriff for two years and held several other political positions. He is survived by his wife.

Walter Lee Taylor, 39, president of the Keystone Spring Works, Thirteenth and Buttonwood streets, Philadelphia, died at his residence, 3630 North Eighteenth street, on March 19, after three weeks illness. Mr. Taylor was born in Georgetown, Del., and went to Philadelphia at an early age. At 14 he went with the Keystone Spring Works as an office boy. At the time of its reorganization in 1904, when the style of the business was changed from a partnership to a corporation he was made president. Mr. Taylor was an authority on iron and steel, and especially on springs for horse-drawn vehicles and automobiles. He was a member of the Carriage Builders' National Association; the Carriage and Wagon Builders' Association of Philadelphia; and several secret and social organizations. The funeral was attended by delegations from the above-mentioned organizations. He is survived by his widow and one son. The Keystone Spring Works will choose a new president from the present directorate, at a special meeting of the board of directors this month.



Benjamin Rushmer, 78, a retired carriage manufacturer, died at his home in Columbus, O., April 8, from heart disease. He had been a Columbus resident 48 years and retired ten years ago. He had been ill for a year. He was a native of Norfolk, England, and went to Columbus in 1868. He is survived by his widow, two sons and two daughters.

Owen T. Sanderson, 38, of the Cleveland (O.) Hardware Co., died March 6, after an illness of a year. He was born in Cleveland in 1878, starting with the Cleveland Hardware Co. in 1895; in 1900 he represented the company in the central states; two years later he was transferred to the south, making Maryland, Virginia, West Virginia, North and South Carolina, Georgia and Alabama. In 1911 he was appointed manager of the top hardware department. He is survived by his widow and two daughters.

George L. Summers, 78, founder of the Summers Buggy Co., Barnesville, Ga., died February 20. He had been in declining health for several months. Mr. Summers was one of the leading buggy manufacturers of the south and had resided in Barnesville for more than 50 years. Three sons and one daughter survive him.

George F. Schantz, 85, pioneer wagon builder of Louisville, Ky., died recently of senility. He is survived by his widow and four children.

Truck Makers Break Delivery Records

Practically all of the truck makers that are sending trucks to Mexico have broken all speed records for prompt shipment.

Less than 22 hours after receiving instructions from the war department, a motor transport of 27 Packard trucks and 33 expert mechanics and chauffeurs left for the Mexican front to join General Funston's expedition into the southern republic.

A Cemented Tire Causes Loss of Battle

That a poorly cemented "solid" rubber tire could have a deciding influence on a battle would be incredible were it not for the letter a driver in the Supply and Munition Column, of British Army Service Corps in France, to a friend in England, describing how a fight near Ypres was lost by the British some months ago. The tire was on the front wheel of a big motor truck, leading an ammunition column at high speed toward the scene of the heavy fighting. Suddenly the entire outside of the tire came off, leaving a layer of rubber around the wheel about half the thickness of the original tire. The truck swerved violently, finally going half into the ditch, and blocking the road for nearly half an hour. In the meantime a section of the British front had to fall back because of lack of ammunition. Examination of this tire showed that it had evidently been made up of two layers with smooth edges, the two halves being cemented together. Under the heat and friction of the drive the two halves came apart and the expensive accident resulted. Truck tires of this type usually are molded from one solid piece, and an investigation is said to have been started, with the idea of discovering whether other tires from the same factory were made in a similar manner.

Separating the Chips

In factories such as the Timken-David Brown Co., manufacturers of worm gearing for commercial cars, the separating of two dissimilar metals such as bronze and steel has been quite a problem. In this plant the chips thrown off by the cutters which cut the teeth in the bronze worm wheel are saved and remelted. To get the highest market price for these bronze chips they must be clean and free from any other metal. As it is practically impossible to collect these bronze chips from the machines without getting a certain amount of steel chips at the same time, some method of classifying and separating these two dissimilar metals had to be devised.

This also occurs in factories which do considerable aluminum work. By a very clever system of electromagnets, scrap, which would ordinarily lose in value considerably by the mixture of foreign material, is now gone over carefully and the foreign matter, such as iron and steel, is automatically lifted out.

Celebrates Fiftieth Anniversary

The fiftieth anniversary of the Merchant & Evans Co., Philadelphia, has just been celebrated, and the company has completed the removal of its general offices and warehouses to the new building erected adjoining its works on Washington avenue, between 20th and 21st streets. It has plants in Philadelphia, Wheeling and Chicago, and offices and warehouses in Philadelphia, New York, Baltimore, Cleveland, Chicago and Kansas City. Added to the extensive line of metal products the company also handles automobile clutches, alignment joints, rear axles, jack shafts, transmissions, grease cups, metal tire cases and completely erected gasoline motor trucks and tractors.

A New System of Repairing Tires

The procedure of the average repair man when mending an injured tire has heretofore been decidedly crude, for he did not remove the damaged parts, but simply laid

on one, or a series of patches that destroyed the resiliency of the tire in their neighborhood, and which, on account of their unsuitable or unyielding character, were sure to work their own destruction in time. One of the prominent tire companies has given out instructions for making correct repairs, which include the complete removal of all defective portions, and the insertion of proper materials to effect a perfect renewal of the injured portion of the tire. The instructions are very simple and clear, and no new tools are required to carry out the improved methods; moreover, the cost and time are not increased. The improved methods will be appreciated by all automobilists in view of the increasing cost of tires.

WANTS

Help and situation wanted advertisements, 1 cent a word; all other advertisements in this department, 5 cents a word; initials and figures count as words. Minimum price, 30 cents for each advertisement.

PATENTS

Patents—H. W. T. Jenner, patent attorney and mechanical expert, 606 F St., Washington, D. C. Established 1883. I make a free examination and report if a patent can be had and exactly what it will cost. Send for circular.

Index To Advertisers

Cargill Co., The.....	3d cover
Carter, Geo. R., The, Co.....	40
Columbus Bolt Works.....	4th cover
Correspondence School of Carriage and Motor Carriage Drafting	40
Dowler, Chas. L.....	40
Du Pont Fabrikoid Co.....	1
Eccles, Richard, Co.....	40
Fairfield Rubber Co.....	40
FitzGibbon & Crisp.....	4th cover
Hotel Martinique	39
International Rubber Co.....	40
Lawson Co., F. H., The.....	1
Landers Bros. Co.....	40
Mulholand Co., The.....	40
O'Bannon Corporation	1
Payne Co., E. Scott.....	40
Porter, H. K.....	40
Sheldon Axle and Spring Co.....	2d cover
Sherwin-Williams Co., The.....	1
Standard Wheel Co.....	4th cover
Standard Oil Cloth Co., Inc., The.....	2
Stewart-Mowry Co.	39
Technical School for Carriage Draftsmen and Mechanics	3d cover
Wilcox, D., Mfg. Co., The.....	2d cover
Willey Co., C. A.....	1
West Tire Setter Co.....	2d cover
White-Quehl Mfg. Co.....	40

Make Your Dollar Produce More in a New York City Hotel

TWO SPECIALTIES:

\$2.50 perday

A pleasant room with private bath, facing large open court. (Not one room, but one hundred of them.)

Also Attractive Rooms Without Bath, \$1.50 Per Day

The restaurant prices are most moderate.

600 ROOMS



\$3.00 perday

An excellent room with private bath, facing street, southern exposure. (Not one room, but eighty-seven of them.)

The most central location in **NEW YORK**, equally convenient for amusements, shopping or business.

400 BATHS

HOTEL MARTINIQUE

On Broadway, 32d to 33d St., NEW YORK

All Baggage Transferred Free to and from Pennsylvania Station

The House of Taylor

Chas. Leigh Taylor, Pres. W. S. Gilson, Vice-Pres. W. Chandler, Jr., Manager

THIS TRADE MARK MEANS MUCH TO VARNISH USERS

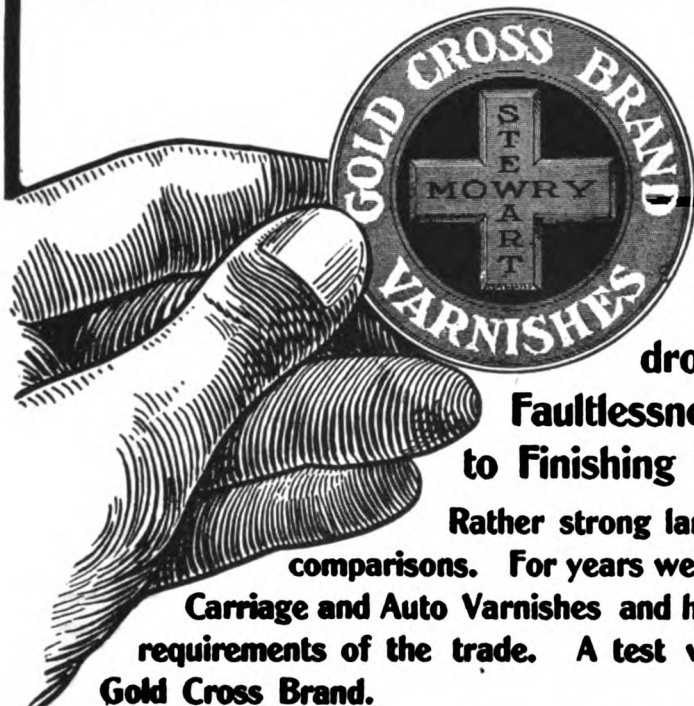

It signifies Quality. It is placed only on the best line of Varnishes we make---our Gold Cross Line. We stake our reputation on every drop that bears this brand. It implies

Faultlessness, and has no superior from Japan to Finishing Varnish.

Rather strong language—but we can prove it; and we court comparisons. For years we have been making the most complete line of Carriage and Auto Varnishes and have put some very intensive study into the requirements of the trade. A test will convince you of the superiority of the **Gold Cross Brand.**

STEWART-MOWRY CO., CHICAGO, ILL.

BUSY BUYERS BRIEFS

CHARLES L. DOWLER
 CARRIAGE AND WAGON HARDWARE
 108 North Third St., Philadelphia, Pa.
CUSHION MANUFACTURER
 Pure Stearic Acid Candles. Wheel Stock. Snow
 Flake Axle Grease.

Buckram, Webbing,
 Mohair, Bow Lining and Strain Straps,
COLORS TO MATCH
 Burlap, Transparent Celluloid, Sheetings
 and Cushion Canvas.
 We Guarantee prompt shipments, best goods, lowest prices.
Landers Bros. Co., Toledo, Ohio

**MULHOLLAND
 BUGGY SPRING**
 Reduces weight of springs one-half.
 Made in one size only but will fit bodies
 of all widths.
 Write for further particulars and prices.
THE MULHOLLAND CO. DUNKIRK, N. Y.



LINED



UNLINED

White's Brazing Sleeves

For applying Rubber Tires
 Send for Samples.

WHITE-QUEHL MFG. CO.

431 E. Pearl St.
 CINCINNATI, OHIO

E. SCOTT PAYNE CO.
 Carriage and Automobile
HARDWARE
 Horse - Shoers' Supplies
 362-364 North Gay St., Baltimore, Md.

Automobile and Carriage Leathers,
Leather Weits and Gimps
 All Kinds of Leather Specialties
 WRITE US FOR PRICES
THE GEO. R. CARTER CO.
 CONNERSVILLE, IND.

Results Always Follow
 Advertising in
THE HUB

It Pays
 Others
 It Should
 Pay You

PORTER'S BOLT CLIPPERS
 "Easy" "New Easy" Allen-Randall



To Cut 5-16, 3-8, 1-2, 5-8, 3-4 Inch.

H. K. PORTER, EVERETT, MASS.

CARRIAGE—WAGON—AUTOMOBILE
 AND SPECIAL
DROP FORGINGS
 QUALITY—THE
 BEST
Richard Eccles Co., Auburn, N. Y.
 PROMPT
 SERVICE.
 WRITE FOR CATALOG.
 SEND BLUE-PRINTS OR MODELS
 FOR OUR QUOTATIONS—IT WILL PAY YOU

THE FAIRFIELD RUBBER COMPANY

Manufacturers of

Carriage Cloth, Imitation Leather,
Automobile Cloths, etc.

FAIRFIELD, CONNECTICUT

Established 1886

**Correspondence School of Carriage and Motor
 Carriage Drafting**

A thorough, practical tuition is given through this correspondence school. The theory and practice of construction, bookkeeping, perspective. Many men now hold good positions through taking the courses of instruction.

Principal, **THOS. MATTISON,**

Hillside Avenue, Bitterne Park,

Southampton, England

Author of "The Coach Body Makers' Guide," \$3.00; a practical treatise on "The Suspension of Carriages," "Bookkeeping," and other carriage building works.

"INTERNATIONAL" RUBBER CARRIAGE CLOTH

The Rubber Carriage Cloth of **SERVICE** and **QUALITY**

INTERNATIONAL RUBBER CO.

Write for Samples and Prices

225 Fifth Avenue, New York

Carriage Mechanics

Desiring to improve their present
Condition should attend the

TECHNICAL SCHOOL

FOR

Carriage Draftsmen and Mechanics

SUPPORTED BY THE

Carriage Builders' National Ass'n

The object of the School is to teach men to design vehicles and make working drawings, and to otherwise facilitate their work in the shop. Only those men employed in carriage or automobile building or their accessory trades are admitted to its privileges.

The classes are conducted in three divisions, viz.: Corresponding, Day, and Evening. The former is open during the entire year, while the day and evening classes are in session only from October 1 to April 1.

The tuition is moderate.

For prospectus and full particulars, write to the instructor,

ANDREW F. JOHNSON,
20 West Forty-fourth St.,
NEW YORK CITY

Cargill Service

has brought to the Cargill Company more Vehicle Catalogues than are made by any other printing house in America.

Cargill Quality is bringing The Best Automobile Catalogues to our plant for Complete production—watch for our imprint in the Season's best books.

THE CARGILL COMPANY

DESIGNERS
ENGRAVERS



PRINTERS
& BINDERS

Grand Rapids, Michigan

WHAT IT IS

The American Harness and Saddlery Directory

The 1915 Edition

An extra painstaking revision of the names (and other information as below) constituting the Retail Harness Trade, has been completed for this year's issue of the Directory, and we think the work is so important and worthy that the

1915 Price Is \$5 Per Copy

and it is very moderate for what is offered in a work that is

Indispensable for Reference

for copying of addresses, and for all purposes usual in a directory.

Just a Sketch of Its Contents

The list of the **WHOLESALE** and **JOBGING TRADE** is so arranged as to make it convenient to separate the association members from those not so recognized.

The **RETAIL HARNESS MAKERS** of the United States and Canada comprise the principal part of the Directory, arranged by State, Town and County, and in the large cities, the street and number is given. Those rating (approximately) over \$1,000 are marked.

A list of **HARNESS DEALERS** as distinguished from retail harness manufacturers, is also given. The value of this list to those who solicit the vehicle, implement, hardware and department stores will be readily appreciated.

A list is also published of **Export Commission Merchants**, giving the class of merchandise they handle.

PUBLISHED BY

THE TRADE NEWS PUBLISHING COMPANY

PUBLISHERS OF "HARNESS"

EDISON BLDG., COR. ELM AND DUANE STS., NEW YORK

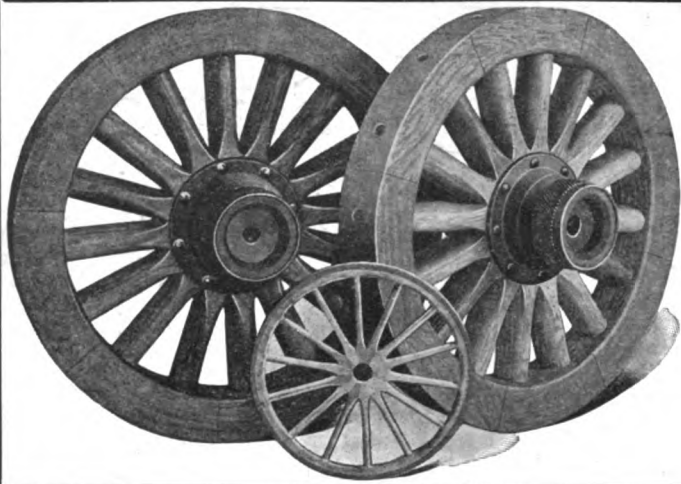

Standard Wheel Co.

Terre Haute, Ind.

Manufacture all kinds and
all sizes of Wheels for
Carriages, Wagons and Motor Vehicles

Quality First

AUTOMOBILE BODIES

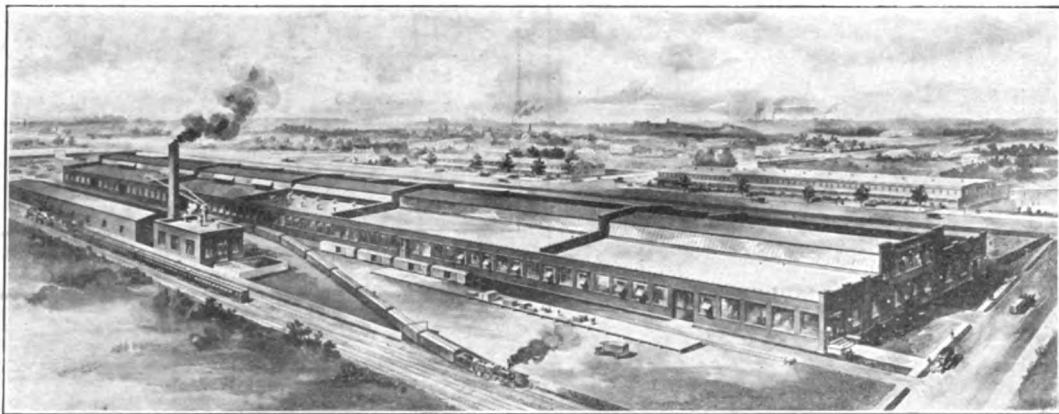

A large corps of skilled workmen and a factory with special
equipment and facilities to produce high grade work at
reasonable prices

Exclusive designs sent upon request

FITZGIBBON & CRISP, Inc.

Trenton

New Jersey

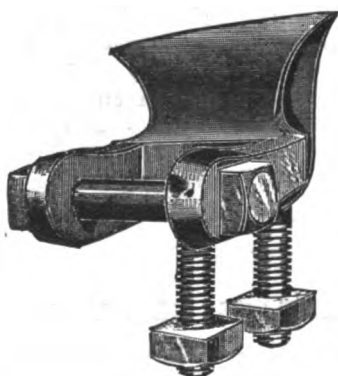

Skewed Shaft Couplings

**Regular or Oval Patterns
For High Arched Axles**

Furnished in rights and lefts for any height of arch. Oval Axle
Clips $\frac{5}{8}$ or $\frac{3}{4}$ width to match Oval Couplings. Bolts, Clips,
Couplings, Carriage Hardware and Special Forgings

Catalogue "H" and Prices on Application

COLUMBUS BOLT WORKS COMPANY
COLUMBUS, OHIO

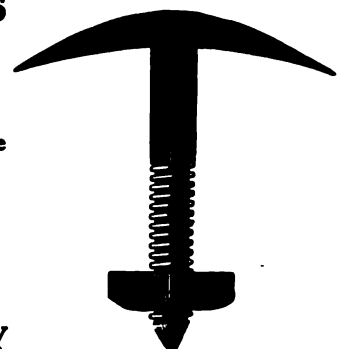

The Hub

CARRIAGES - AUTOMOBILES - WAGONS - TRUCKS



TRADE NEWS PUBLISHING CO.
EDISON BUILDING, ELM & DUANE STS.,
NEW YORK

SHELDON AXLES AND SPRINGS

**For Horse-Drawn and Power-Propelled
Vehicles of All Kinds**

JUST ENOUGH BETTER THAN OTHERS TO BE NOTICEABLE

When you specify "Sheldon" you are not experimenting with experiments, but are getting Axles and Springs with years of manufacturing experience back of them—Axles and Springs that are selected for important work where conditions make reliability supremely important

SHELDON AXLE AND SPRING COMPANY, WILKES-BARRE, PA.

LARGEST AXLE AND SPRING FACTORY IN THE WORLD

WILCOX

FINE
FINISHED
FORGED

**CARRIAGE HARDWARE
AND GEAR IRONS**

Write for Prices and Catalog

The D. Wilcox Mfg. Co.
MECHANICSBURG, PA.

The WEST Hydraulic Tire Setter WILL CUT DOWN EXPENSE

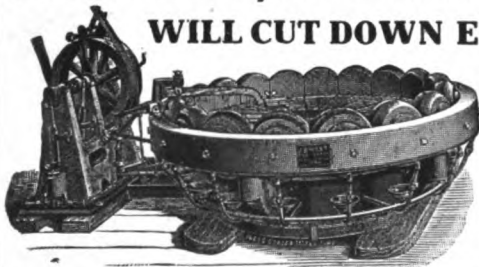

Tires set cold in one minute. This machine saves time—does the work better and quicker, does a way with burned streaks. Only necessary to measure one wheel in a lot. Does not char the rim, and

thus make the tire loosen prematurely. Saves resandpapering of wheels. This machine is now increasing the profits of many manufacturers. Send for catalog and read about it.

WEST TIRE SETTER CO., ROCHESTER, NEW YORK



"Self-Propelled Vehicles"

Fifth Edition, Revised.

A practical treatise on the theory, construction, operation, care and management of all kinds of Automobiles.

By

JAMES E. HOMANS, A.M.

Contains 608 pages and upwards of 500 illustrations and diagrams, giving the essential details of construction and many important points on the successful operation of the various types of motor carriages driven by steam, gasoline and electricity.

This work is now the accepted standard, explaining the principles of construction and operation in a clear and helpful way. This book will be sent postpaid to any address in the United States, Mexico or Canada upon receipt of \$2.00.

Address

Trade News Publishing Co.

Edison Bldg., Cor. Elm and Duane Sts., New York

Convince Yourself

IN YOUR OWN FACTORY THAT



"Motor Quality IS Superior to Coated Splints." That it is stronger, more uniform in quality throughout and works and wears better, and is more economical.

Fabrikoid has been adopted by the majority of the largest vehicle makers in the country as the standard upholstery material, and is giving perfect satisfaction.

Get in line and save time, money and worry by using Fabrikoid in every case where real grain leather is prohibitive.

State your line and send for samples today

DU PONT FABRIKOID CO.

Wilmington, Delaware

Works at Newburgh, N. Y.

Canadian Factory and Sales Office: TORONTO

WILLEY'S COLORS

The **RECOGNIZED STANDARD**



C. A. WILLEY CO.

COLOR GRINDERS

and Manufacturers of Specialties in

CARRIAGE, AUTOMOBILE AND CAR

PAINTS

COLORS, VARNISHES, ETC.

HUNTER'S POINT, NEW YORK CITY

THE F. H. LAWSON CO.

CINCINNATI, O.

Manufacturers of

Metal Buggy Seats

FLEUR DE LIS PATTERN



NEW STYLES—ALL SIZES

STRONGEST—NEATEST—BEST

No Solder Used

YOUR VEHICLE SELLS WHEN EQUIPPED WITH

LAWSON'S METAL SEATS

Write for Prices

O'BANNON ARTIFICIAL LEATHER

Reg. U. S. Pat. Off.

Moleskin Quality

The Best Leather Substitute

All the

Standard Leather Grains, Colors and Finishes

GUARANTEED

Against Cracking, Peeling or Wearing Down
to the Cloth Backing

WRITE FOR SAMPLES

O'BANNON CORPORATION

200 Fifth Avenue, New York City

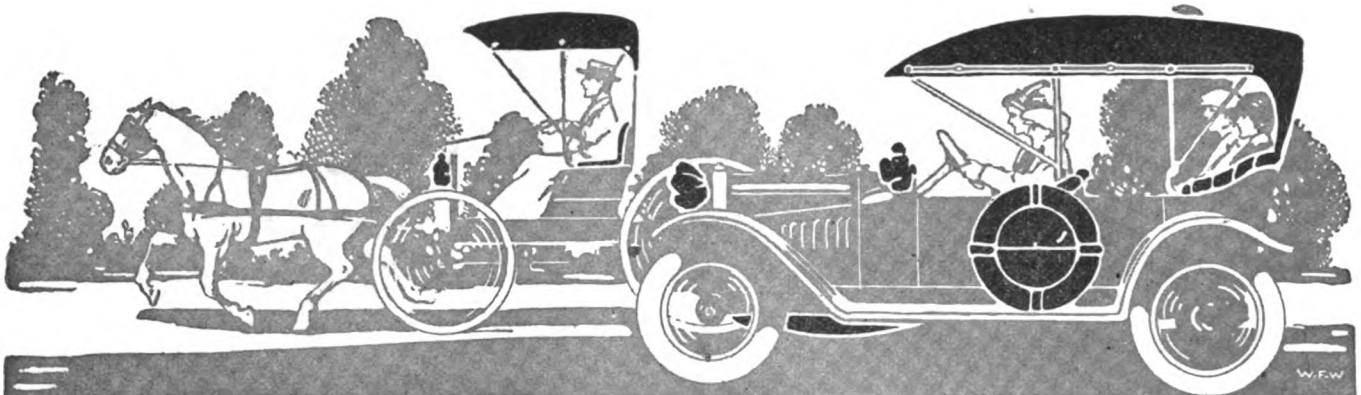

The Leading Leather Substitute For Carriage and Auto Trade

When you need a leather substitute, join the other progressive carriage and automobile manufacturers and select the leading leather substitute—

MERITAS

LEATHER CLOTH

A leather substitute is but a substitute after all—but Meritas leather cloth is made and finished to withstand the hardest wear and handling.

Meritas Leather Cloth is durable, of non-cracking finish and guaranteed perfect by our trademark stamped on the back of every yard. You will like the selection of colors and the lasting finish of this serviceable leather substitute.

Meritas Leather Cloth is made in muslin, duck and drill; dull or glazed; smooth or grained; in black and colors.

Learn more about this leading leather substitute by writing for sample book—sent on request.

Write
for
sample
book of
MERITAS
LEATHER CLOTH
NOW

The Standard Oil Cloth Co., Inc.

320 Broadway, New York

The Hub

Vol. LVIII

MAY, 1916

No. 2

Published Monthly by

THE TRADE NEWS PUBLISHING CO. OF N. Y.

J. H. WRIGHT, *President* G. A. TANNER, *Secretary and Treasurer*

EDISON BUILDING, COR. ELM AND DUANE STS., NEW YORK

Other Publications of Trade News Publishing Co.:

HARNESS (monthly).....per year, \$1.00

AMERICAN HARNESS AND SADDLERY DIRECTORY
(annually), per copy, \$5.00

THE HUB is published monthly in the interest of employers and workmen connected with the manufacture of Carriages, Wagons, Sleighs, Automobiles and the Accessory trades, and also in the interest of Dealers.

Subscription price for the United States, Mexico, Cuba, Porto Rico, Guam, the Philippines, and the Hawaiian Islands, \$2.00; Canada, \$2.50; payable strictly in advance. Single copies, 25 cents. Remittances at risk of subscriber, unless by registered letter, or by draft, check, express or post-office order, payable to the order of THE TRADE NEWS PUBLISHING CO.

For advertising rates, apply to the Publishers. Advertisements must be acceptable in every respect. Copy for new advertisements must be received by the 25th of the preceding month, and requests to alter or discontinue advertisements must be received before the 12th day of the preceding month to insure attention in the following number. All communications must be accompanied by the full name and address of writer.

FOREIGN REPRESENTATIVES:

FRANCE—L. Dupont, publisher of *Le Guide des Carrossiers*, 78 Rue Boissiere, Paris. Subscription price, 15 francs, postpaid.

GERMANY—Gustave Miesen, Bohn a Rh. Subscription price, 12 marks, postpaid.

ENGLAND—Thomas Mattison, "Floriana," Hillside avenue, Bitterne Park, Southampton. Subscription price, 12 shillings, postpaid.

Entered in the New York Post Office as Second-class Matter

Combinations to Capture Foreign Trade

After a thorough examination, the Federal Trade Commission has recommended the authorization of industrial combinations in this country for the purpose of meeting the competition of similar industrial combinations authorized and aided by other nations.

Agreement is general among business men that combination in restraint of trade are an unmixed evil to the development of home trade and industry. In foreign trade, however, the situation is entirely different. Not only do other nations permit combinations for the exploitation of foreign markets, but they encourage them. The plans which have been adopted abroad for extension of foreign trade constitute a mobilization of industrial resources for the conquest of foreign markets.

In this warfare the United States is at a great disadvantage because its prohibition of industrial combinations extends to all such combinations, irrespective of whether they are formed to control the home market or to gain a foothold in foreign markets. One of the purposes for which the Federal Trade Commission was created was to conduct an inquiry into foreign trade conditions and to make a recommendation as to what action, if any,

should be taken to enable American industries to compete for foreign trade under the most favorable conditions. Congress should give heed to the report made by the Commission and pass appropriate legislation at this session. The United States will never have a more favorable opportunity for entering foreign markets than is now presented, and it would be folly to throw it away.

Electrical Vehicle Problems

A great deal of space is occupied in this issue of The Hub by a paper on "Electrical Vehicle Problems and Activities," by E. P. Chalfant, read before the Electric Vehicle Division of the National Electric Light Association at its convention held in Chicago, May 22-26. Mr. Chalfant handles the subject in an able and masterly manner, and his paper is well worth reading.

The lamentable showing of production compared with the gasoline car calls for serious consideration on the part of the builders of electric vehicles and central stations, the chief cause of which is in the matter of publicity.

The principal benefactors of an increased output are the central stations and they have been slow in giving the electric vehicle the support it so badly needs.

There is much to be said in favor of the electric vehicle and Mr. Chalfant didn't overlook any points in his excellent paper.

Philippine Trade Expansion

The trade expansion which has taken place in the Philippines since the islands have been under the control of the United States, has been remarkable. The total exports from the islands in 1899 were \$14,847,000. In 1914 they were \$48,690,000.

The total imports in 1899 were \$19,193,000 and in 1914 they were \$48,589,000.

The total foreign trade of the islands was \$34,000,000 in 1899, and the average since the beginning of the European war has been about \$100,000,000.

Metal Wheels Gain in Europe

The war has been responsible for the almost complete elimination of the wood artillery wheel. For truck service the cast-steel wheel is generally employed by the French and Italian armies. The British, while large users of cast-steel wheels, also employ a percentage of disc wheels. For automobile ambulance service and light trucks, particularly those with twin pneumatics at the rear, the steel disc wheel is in a decided majority. American trucks brought into Europe for army service are all fitted with wood artillery wheels. These are allowed to remain, but

Need of a Settled Tariff Policy

The necessity for a settled American tariff policy was emphasized by Dr. Frank R. Rutter, assistant chief of the Bureau of Foreign and Domestic Commerce, Department of Commerce, in an address before the National Gas Engine Association at Chicago. If the country is to hold its own in the bitter competition for trade that will follow the war, the government must be given the opportunity to make favorable commercial treaties with foreign countries. "It should be borne in mind," said Dr. Rutter, "that concessions can not be obtained in the tariffs of other countries if we are not willing to make concessions ourselves."

"A fixed commercial policy is particularly necessary at the present time," said the speaker. "With rumors of trade agreements that will give preferential rates of duty between the Allies, and with rumors of a customs union to cover Germany and Austria-Hungary, we must be in a position to know definitely the effect on our industries of any proposed foreign action. Can we not, if we know the situation well enough to make proper representations, obtain rates of duty that will at least put our products on an equality with those of other countries (a privilege which we do not now enjoy in France) and possibly in a position of even greater advantage?"

The proposed tariff commission was referred to as a step in the right direction, as it would serve the excellent purpose of taking the tariff out of politics. The commission is also authorized to study commercial conditions and to advise regarding commercial policies and commercial treaties, and in this way will be of the greatest possible assistance in establishing a settled tariff policy.

C. B. N. A. Membership Letter No. 3

Clen Perrine, chairman of the membership committee of the Carriage Builders' National Association, and P. E. Ebrez, president of the organization, have mailed Letter No. 3, soliciting membership. It is as follows:

Dear Sir—Our several letters in regard to membership in the Carriage Builders' National Association have so far had no favorable reply from you.

"In union there is strength," and the carriage builders need all of the strength of their united effort, in order to defeat the threatened freight increases. We therefore need your support.

You will receive far more benefit than the face value of \$10 per year (which is the annual membership dues) in the prestige it will give you among the dealers whose associations are co-operating with the C. B. N. A.

This committee will supply free to all members poster stamps, as per sample attached, showing that through this association said member supports this co-operation with the dealers' association. The stamps alone are worth more to you, and cost more than a year's membership in the C. B. N. A. Can you afford to be an outsider in this movement?

Reports from all over the country agree that there has been a decided improvement in the horse-drawn vehicle business during the last few months. There is a revival of interest therefore on the part of the dealer, and it is up to you to join hands in this co-operative movement for the benefit of the trade, and therefore help to present a united front on every occasion where our interests are assailed, or advantage may be gained by united effort.

Send in your application for membership and tell us how many of these membership stamps you can use; they cost you nothing, if you are a member, and will help to establish your position with the dealers as a legitimate manufacturer in the carriage business.

Kindly address your reply to 1630 Gest street.

Discounting Farmers' Notes

Since the uniform note blanks were prepared for members of the Western Association the Federal Reserve Bank has ruled that farmers' notes given for agricultural implements or other farm operating equipment, may be discounted within six months of maturity.

In order to be sure that the form was all right it was submitted to Charles M. Sawyer, chairman board of directors Federal Reserve Bank of Kansas City, and he says that if name of article for which note is given is filled in it will be all the evidence needed to show that the note is agricultural paper. It is made very clear, however, that the obligation must mature at one time. That is, the note must not be drawn payable in specified amounts at different intervals. Hence, if a sale is made payable in instalments and the dealer anticipates discounting it with the Federal Reserve Bank a separate note must be taken for each instalment.

The forms as printed provide for three partial payments. This was for the purpose of saving expense in filing same to hold possession of property.—Implement Dealers' Bulletin.

A Long and Honorable Record

The best wishes of a great host of friends in the vehicle trade will follow E. W. Harral in his retirement from the Fairfield (Conn.) Rubber Co., after holding the reins in that concern since 1880. Mr. Harral says it is hard to leave old and tried assistants, some of whom have been with him for 28 to 32 years. E. W. Harral and his brother, the Major, were conspicuous figures at C. B. N. A. gatherings for many years, where they always occupied large and prominent space for their company. The Major went into retirement several years ago. Under the management of E. W. Harral the company attained a reputation for honest dealing that ought to be a great source of satisfaction to him in the years to come in addition to the pride that every man feels in turning over his property to such excellent hands.

To Tax Motor Vehicles on Road Wear

Because of the wear and tear of the vehicles on the highways, all owners of automobiles and motor trucks will have to pay additional fees to the state of New York within a year. Governor Whitman has signed the Hewitt bill providing for the levy of the fees by February 1, next year.

The bill directs the commissioner of highways, superintendent of public works and the state engineer to adopt a schedule of fees for the registration of omnibuses that carry passengers and trucks for the transportation of freight. They are to classify the vehicles upon the basis of time and extent of use upon the highways relative to the wear and tear of the roads. The schedule is to be turned over to the secretary of state by the first of next year.

C. B. N. A. Convention Announcement

Secretary H. C. McLearn, of the Carriage Builders' National Association, from his headquarters at Mt. Vernon, N. Y., has sent out his announcement in relation to the coming annual convention and exhibition, which is substantially as follows:

The forty-fourth annual meeting of this association will be held in Cincinnati, O., during the week commencing September 24, 1916.

At the same time and place the annual exhibition of parts of vehicles, automobiles, models, new inventions, harness, horse equipment and materials pertaining to the carriage, wagon, automobile and accessory industries, will be held.

The committee in Cincinnati having this in charge have arranged with the Hotel Gibson to have all the different parts of the convention held in their hotel: the convention the business meetings, the reception, the banquet, and the exhibition, so by this everything will be conducted under one roof, in rooms suitable for these purposes.

The following rules and regulations have been adopted to govern the exhibit:

Exhibitors must be either active or associate members of the association.

The exhibits must be confined to models, parts of vehicles or automobiles, and to materials used in the construction of the same, or to coachmen's outfits, harness and horse furnishings. No finished vehicle will be admitted.

For various reasons, so as to get the best results and furnish the proper accommodations to the exhibitors, the committee have arranged and laid off the exhibition hall in sections somewhat different from the usual manner.

The space will be sold according to the following scale of prices:

Nos. 2, 3, 4; 24 x 25, 600 ft., each.....	\$240
Nos. 5, 6, 7, 8, 9, 11, 12, 13, 14, 15, 16, 17, 18, 19, 20, 21; 8 x 12, 96 feet, each.....	40
No. 10; 12 x 16, 192 feet.....	70
Nos. 23, 24, 25, 26; 256 feet, each.....	103
No. 27; 123 x 2 feet.....	49
No. 28; 9.8 x 11.6, 103 feet.....	41
No. 30; 17.8 x 17.11, 296 feet.....	118
No. 31; 15 x 17, 265 feet.....	106
No. 34; 15 x 17.5, 261 feet.....	105
Nos. 36, 37, 38, 39; 8.6 x 13, 110 feet, each.....	45
Nos. 42, 43, 44, 45, 46; 11 x 13, 143 feet, each.....	57
No. 48; 14 x 27, 378 feet.....	151
Nos. 49, 50; 13.6 x 14, 189 feet, each.....	75
No. 51; 14 x 27, 378 feet.....	151
Nos. 52, 53; 7 x 27, 189 feet, each.....	75

Application for any of these spaces can be made at once and they will be assigned in order of application.

The committee will arrange to have the exhibition space policed by day and watched by night, but does not assume the responsibility for loss or damage.

Exhibits can be placed in position on Friday, September 22, and must not be removed until 6 p. m., Thursday, September 28.

The exhibitors will close their exhibits from 10:30 a. m. until 12 noon on Tuesday and Wednesday, so that the attendants and visitors can attend the business meetings.

With these exceptions the hall will be open from 8 a. m. until 6 p. m. from Monday to Thursday, and on Friday until 5.

Floor space only will be sold. This may be furnished by the exhibitor to suit his needs. But the committee or its employes cannot undertake to furnish any of these articles. Exhibitors must not sublet to anyone not members of the association.

No signs in the body of the hall shall be so displaced as to interfere with proper observance of community interest.

The president of the association will appoint a special committee on exhibition to examine the exhibits and make a report to the convention of such articles as show improvement in their special lines, or show a high order of inventive ability.

By resolution passed at the annual meeting held in New Haven, Conn., October 17, 1883, it is required that any firm or company wishing to exhibit goods at the convention should have at least one of its partners or officers a member of the association; and the fact that a representative or employe is a member will not alone be sufficient.

The admission to the exhibition hall shall be by ticket, to be produced at the entrance door on registration. This ticket will be provided free to all members of the association, both active and associate. And also to all carriage, wagon, sleigh, automobile and motor car builders who are not members of the association, but not to any manufacturer or dealer in the accessory goods who is not a member of the association.

The exhibitors will be provided with badges for themselves and their attendants, and these will be delivered to them on the first day the exhibition is open.

Farm Credits Bill Passed

The U. S. Senate has passed what is known as the Hollis rural credits bill. Briefly it creates a farm loan board composed of the Secretary of the Treasury and four other members appointed by the President and confirmed by the Senate. It provides for 12 or more federal land banks, which will be under the control of the farm loan board, each to have a capital stock of not less than \$500,000, contributed in part by the government. Then there is a scheme for joint stock land banks and farm loan associations to borrow from the nearest federal bank 50 per cent of the value of their farms on long termed mortgages at an interest rate which will be fixed by the farm loan board of not more than 6 per cent. There is also a provision under which the individual farmer may apply to the joint land bank. The government may issue bonds against these farm mortgages and these bonds are made lawful investments for public and trust funds. There seems to be a question whether the government assumes responsibility for these bonds.

Pittsburgh Horse Vehicles to Carry Light

The ordinance requiring horse-drawn vehicles to carry a light was passed finally by City Council of Pittsburgh, Pa. The light is to be in a "conspicuous place and visible for a distance of at least 200 feet in front and rear of the vehicle." All horse-drawn vehicles, except those carrying "hay or straw in bulk," are included in the ordinance adopted.

A resolution insisting that the director of public safety enforce the ordinance requiring lights on automobile trucks was approved.

**Drawings by Graduates of the 1916 Class:
of the Carriage Technical School**

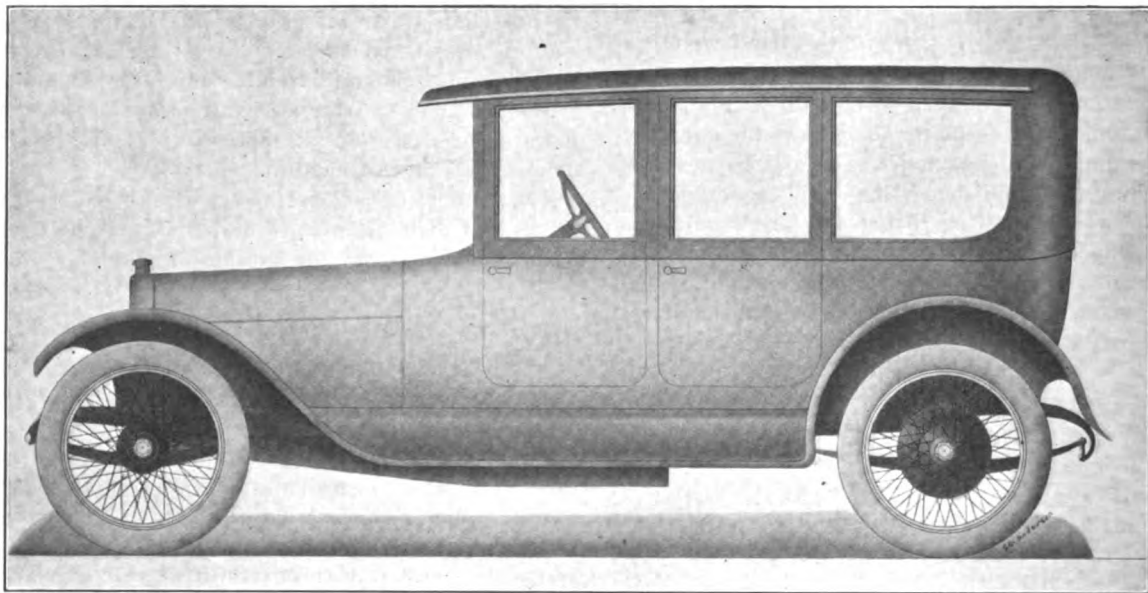

INSIDE DRIVE TOWN CAR—BY S. R. ANDERSON

**Drawings by Graduates of the 1916 Class
of the Carriage Technical School**

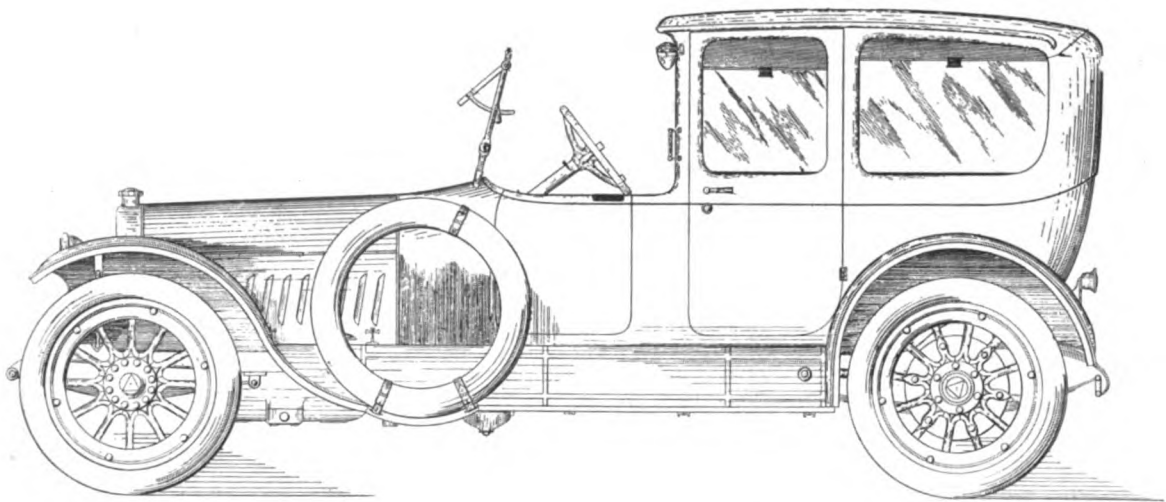

CABRIOLET—BY E. LUNBERG

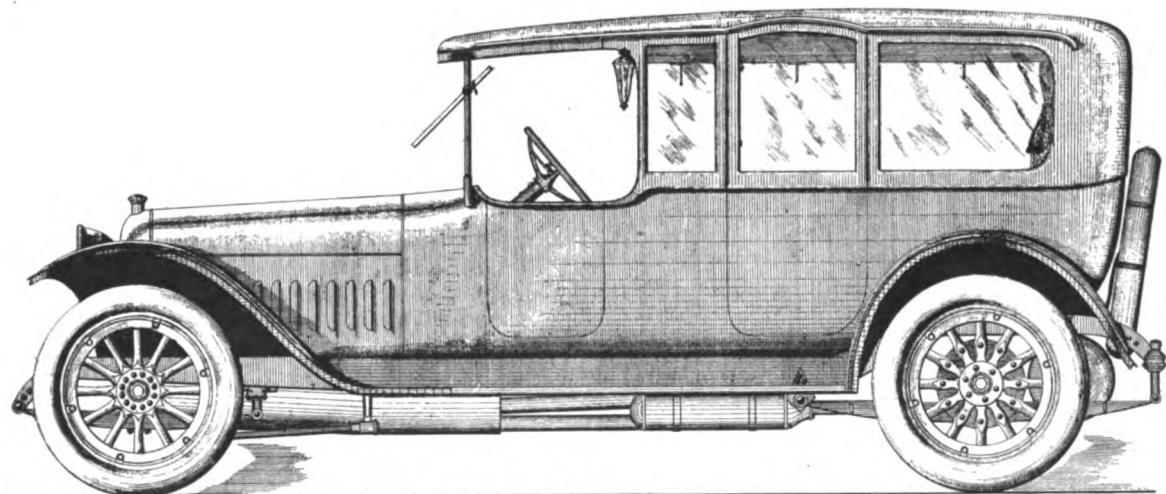

LIMOUSINE—BY WM. PREHN

English View "After the War"

Some time ago a statement was made by a man well known in American financial circles that following closely upon the declaration of peace in Europe there would be a great tide of immigration to the United States. This gentleman saw in the future vast armies of men and capital coming to this country, and urged manufacturers to make hay while the sun is shining. His was a gloomy view. He believed there would be sharper competition between the newcomers and the present manufacturers than ever came from the manufacturers of Europe, operating from their native heaths.

The financier view with great apprehension the vastly increased immigration to the United States, but all men do not see the picture just as he saw it. Hon. Champ Clark, in a recent letter, expressed the belief that the immigration into this country during the next generation will be negligible. He cites the fact that so many have been killed on both sides of the great war that every able-bodied man will be needed and used at home in the restoration of normal conditions.

This view is borne out by the editor of *Arms and Explosives*, of London, who in a recent number said, "manufacturing facilities will be less to the extent that many workers will have dropped out of the ranks, by death or disablement, the last named as well as the dependents of the first named becoming a charge upon the community."

It has been believed by many that a majority of the immigrants into the United States come here because they want to reside in a republic, but undoubtedly this is not true. The stream of Irishmen into this country ceased as soon as working conditions became better in Ireland. Then we had the German immigrant, and finally he ceased to come. His condition in Germany was practically as good as in America.

The real anxiety should be and is felt for and by the warring nations. Looking into the future the editor of *Arms and Explosives* says:

"Anxiety very naturally prevails in gunmaking circles with regard to future prospects. All luxury businesses, and many which supply what only rank as necessities to those with well filled purses, are influenced in ordinary times by the prevailing standard of prosperity. According to accepted financial tests the war is eating up wealth at a rate which will leave the world poorer to the extent of cutting away margins over and above the income necessary for ordinary living expenses. In addition to actual wealth consumed the great migration of money to America will have the effect of placing many countries in the position of paying tribute to that quarter. The other side of the picture is that the consuming power of humanity and the productive capacity of the earth will remain much at their old level. Manufacturing facilities, on the other hand, will be less to the extent that many workers will have dropped out of the ranks by death or disablement, the last named, as well as the dependents of the first named, becoming a charge upon the community.

"Diminished commercial activity in countries adversely affected by the war will react on those other countries which have been able to maintain their manufacturing facilities in working order. Germany, as a great competitor in the world's markets, is certain, whatever the result of the war, to emerge with weakened financial credit and with a mountain of prejudice and suspicion operating against her which may require generations to remove.

Austria will suffer from the same kind of disability as that which is bound to prejudice her neighbor's efforts to resume peaceful industry. Unhappy Belgium, even with the assistance which her allies will feel honored to provide, must take years to restore the well-ordered activity of her hard-working population. The ravaged industrial area of France will likewise take some time to re-establish all its former thriving condition. Russia, which by her mineral development was fast becoming one of the important industrial nations, will suffer from the interruption of her activity.

"The total position is that a partially crippled world must, as soon as may be, set to work to repair the disasters caused by the war and to resume those relations toward the distant pastoral countries whose development has for the moment been arrested. The uplifting of the war cloud, which has hovered for the past half century over the nations of the old world, can hardly have any other effect than to stimulate activity in all producing centers. Arrears of supply must, as a matter of duty, be overtaken with all speed. The work of reconstructing that which has been destroyed will equally press for attention. Notwithstanding the burden of the recently enacted taxation manufacturers will endeavor to provide themselves with the funds necessary for coping with the demand which will assail them from all sides. They will also be concerned to find peaceful uses for the extra plant laid down to supply the necessities of war. Though the time has not arrived for discussing these matters in detail the end of the present world's war will certainly witness many inducements for resisting the lethargy which usually follows a life and death struggle between nations."

Button to Stop Car From Rear Seat

A New York inventor recently brought out a device whereby, in cases of emergency, the occupants in the rear seat of an automobile can bring the car to a stop by push buttons which shut off the engine and apply the brakes. It is especially in instances when the chauffeur fails in his duties or is suddenly incapacitated that the invention is most valuable.

The device serves to apply the brakes and control the power of the car on which it is installed by means of a spring held under compression, which is electrically released. It weighs but 15 pounds and can be mounted in any car without interfering with the existing equipment. One novel feature of the system is that while the occupants of the rear seat can apply the brakes and bring the car to a halt in time of emergency, provision is made to prevent them from interfering with the control of the vehicle at all times when the chauffeur is properly driving the car. Furthermore, in an emergency the chauffeur can apply the brakes by means of the device by depressing a push button conveniently located on the steering wheel.

Ed. Maxwell Has Paralytic Stroke

W. E. Maxwell, purchasing agent of the Parry Mfg. Co., Indianapolis, Ind., suffered a stroke of paralysis at his home on May 26. His condition at one time was very critical. He and his wife were at the table taking dinner with a friend when he was suddenly stricken, his left side being affected. From latest information, however, he was recovering rapidly and it was hoped that he would soon be back at his office ready for business.

Definitions of Bodies and Axles

The report of the nomenclature division of the Society of Automobile Engineers submitted to the standard committee at its meeting on June 12 included a definition of different types of bodies. "It is thought," says the report, "that some authority should take action to make possible the use of names which will be understood generally, rather than those which are meaningless except to persons conversant with the terminology peculiar to individual manufacturers. It is surprising how many distinctly different types of body are being sold under the name 'brougham,' for instance."

The definitions are as follows:

- Roadster**—An open car seating two or three. It may have additional seats on running boards or in rear deck.
- Coupelet**—Seats two or three. It has a folding top and full-height doors with disappearing panels of glass.
- Coupe**—An inside operated, enclosed car seating two or three. A fourth seat facing backward is sometimes added.
- Convertible Coupe**—A roadster provided with a detachable coupe top.
- Clover Leaf**—An open car seating three or four. The rear seat is close to the divided front seat and entrance is only through doors in front of the front seat.
- Touring Car**—An open car seating four or more with direct entrance to tonneau.
- Salon Touring Car**—A touring car with passage between front seats, with or without separate entrance to front seats.
- Convertible Touring Car**—A touring car with folding top and disappearing or removable glass sides.
- Sedan**—A closed car seating four or more all in one compartment.
- Convertible Sedan**—A salon touring car provided with a detachable sedan top.
- Open Sedan**—A sedan so constructed that the sides can be removed or stowed so as to leave the space entirely clear from the glass front to the back.
- Limousine**—A closed car seating three to five inside, with driver's seat outside, covered with a roof.
- Open Limousine**—A touring car with permanent standing top and disappearing or removable glass sides.
- Berline**—A limousine having the driver's seat entirely inclosed.
- Brougham**—A limousine with no roof over the driver's seat.
- Landulet**—A closed car with folding top, seats for three or more inside, and driver's seat outside.

The definitions of the general type of rear axles are as follows:

- Dead Axle**—An axle carrying road wheels with no provision in the axle itself for driving them.
- Live Axle**—General name for type of axle with concentric driving shaft.
- Plain Live Axle**—Has shafts supported directly in bearings at center and at ends, carrying differential and road wheels. (The plain live axle is practically extinct).
- Semi-Floating Axle**—Has differential carried on separate bearings, the inner ends of the shafts being carried by the differential side gears, and the outer ends supported in bearings. The semi-floating axle shaft carries torsion, bending moment, and shear. It also carries ten-

sion and compression if the wheel bearings do not take thrust, and compression if they take thrust in only one direction.

Three-Quarter Floating Axle—Inner ends of shafts carried as in semi-floating axle. Outer ends supported by wheels, which depend on shafts for alignment. Only one bearing is used in each wheel hub. The three-quarter floating axle shaft carries torsion and the bending moment imposed by the wheel on corners and uneven road surfaces. It also carries tension and compression if the wheel bearings are not arranged to take thrust.

Full-Floating Axle—Same as three-quarter floating axle except that each wheel has two bearings and does not depend on shaft for alignment. The wheel may be driven by a flange or a jaw clutch. The full-floating axle shaft is relieved from all strains except torsion, and in one possible construction, tension and compression.

The different types of live axle can be driven by bevel gear, spiral bevel gear, worm, double-reduction gear or single chain.

In other constructions, the rear wheels are driven by double chains, internal gears, or jointed cross-shaft.

Semi-Annual Meeting of National Association of Tanners

The National Association of Tanners held its semi-annual meeting on Thursday, June 1, at Hotel Astor, New York City. President H. Fred Lesh, in his address, mentioned the establishment of the Boston office and stated that the members, on being canvassed, were practically unanimously in favor of dues being raised to \$50. All members, except three or four, paid the new rate. Ample funds are necessary for the important and expanding activities of the National Association of Tanners, and it is far better to spend money and do things rather than economize unwisely. He also paid special attention to the problems confronting American tanners, on account of the European war. The question of anthrax and disinfection of hides was discussed in a clear and emphatic manner.

George H. Raymond, of Hans Rees' Sons, discussed the Tanning School at Pratt Institute, and stated that 62 members of the National Association of Tanners have offered to subscribe toward the \$15,000 a year subscription fund for establishing a research laboratory. Eighteen of these subscriptions are based on \$300 a year for five years, and out of the 18, 14 are willing to aid in underwriting the fund.

How the Japanese Advertise

An exchange calls attention to an amusing statement, in an issue of the Biblical World, which appeared in an article entitled, "The Japanese Bible." The item states that the Japanese merchants have secularized the sacred tunes to such an extent that it is a common sight to see a band of Japanese marching through the streets advertising tea, rice and dried fish to the tune of "Onward, Christian Soldiers," or "Nearer, My God, to Thee."

To make a still more ludicrous contrast, the advertisers dress in grotesque costumes and perform acrobatic tricks to the tune of the hymn.

Meeting of Southern Vehicle League

The regular annual meeting of the Vehicle League held in Greensboro, N. C., on May 16 was attended by a representative gathering of the buggy and wagon manufacturers covering the entire southeastern territory. Many vital subjects of especial interest to the vehicle manufacturing trade at this particular time, were up for discussion and disposal.

President Hackney's annual address, as usual, was both timely and instructive, regarding not only what had been accomplished in the past, but predicted that the future was still bright before the vehicle manufacturers.

The board of governors has had the affairs of the league in charge during the past year and have given them necessary attention. There is a present membership of 27. Three new members were recommended for reception. The conduct of the credit bureau has been most satisfactory during the year and the finances of the league are in good condition.

The report of the commissioner showed a great volume of work accomplished during the year, and the accumulation of credit information that is invaluable to our members. The moral effect of the three year existence of the league has been most wholesome in bringing about a better business standing of the vehicle industry throughout the southeastern section.

As the credit bureau had proved so successful in protecting the members from loss, it was decided to enlarge the scope of the organization and admit all vehicles and allied industries interested in ledger experience exchange.

One of the cardinal principles of the league is to foster the development of sound and sane business practices in the vehicle industry so that it may take its proper place among other industries that command the respect of the best business and banking interests of the country. To this end the hitherto unrestrained guarantee on vehicles has been discouraged and the adoption of reasonable terms to fit the economic conditions of the south has been most earnestly advocated.

More than special interest was taken during the open discussion on the tremendous advance in the cost of raw material, and it developed that the advance in the cost of steel, iron, cloth, carpets, and even woodwork would completely wipe out all margin of profit if the manufacturer did not watch his cost and raise his selling price accordingly.

The old officers and governing board and commissioner were reelected for another year and the same schedule of fees adopted that has prevailed the past 12 months.

The meeting was one of interest and enthusiasm from start to finish and the prevailing feeling among all present was one of optimism. H. A. WHITE, Secretary.

Returning to Horses

A prominent dealer told the London (Eng.) Daily Graphic that since the budget and the announcement of the new tax he had received more inquiries for horses for private use than during the whole of the previous twelve months. "For some months now," he said, "many wealthy people have been thinking of returning to horses. It has not been entirely a matter of expense, but so many chauffeurs have gone, gasoline has been difficult to obtain, and finally, in view of the government's pronouncement against pleasure motoring, they have not cared to

use their cars. The matter of looking after horses is not so difficult as with motor cars. There are old men on every estate brought up from boyhood with horses who can be used. So old carriages, dog carts, governess cars, and all sorts of vehicles which have long been rusting in the stables are being brought out again. Others want to go back to horses for purely economical reasons; they cannot afford to run their cars with the increased and increasing price of gasoline and the new tax. But while many people want horses, they are by no means easy to obtain, and there is a scarcity of the light types not wanted by the military, because there has been no great demand for them and consequently breeding has fallen off."

Why the Increase in Prices of Paper?

Merchants who are compelled to pay what seems to be exorbitant prices for all kinds of paper stock and who find the increased price in every sheet of printed matter are wont to ask why. The only answer is, "War." That may satisfy some, but is the war responsible? We are told that the increase is due to the curtailment of the imports of pulp wood. But statistics fail to show such a shortage as one might expect. Then we are told that the cost of pulp wood has advanced, but it has not advanced in harmony with the advance in the cost of paper. For the eight months ending with February, 1914, there were imported into the United States 704,591 cords of pulp wood, having a value of \$4,847,598; during the same period of 1915 the pulp wood imports totaled 662,905 cords, having a value of \$4,547,588, and in 1916, 632,070 cords, having a value of \$4,143,941.

These figures fail to show cause for the price of paper of various kinds advancing in price from 20 to more than 100 per cent. To the man unfamiliar with all the details of paper manufacture it looks very much as though there is a gentleman of color in the proverbial wood pile. He may be in the pulp. We are told that there is a tremendous scarcity of paper, but the average consumer of paper has been able to buy all the paper he wants, provided he has been able to reach the unprecedented price. During the past few weeks there has been a slight decline in the price of some grades of paper, but the decline has been so small as to be next to invisible.

This increased cost of doing business has been quite an item with the dealers who do extensive mail advertising. The government has urged everybody to save waste paper, and this is all well and good, but if the government will start a search for the aforesaid gentleman of color in the pulp pile, earlier relief may be had.

Automatic Door Opener

A large packing concern in California has installed an automatic means for opening the doors of its horse stable which allows the horses to escape at any time of the day or night if there is danger of fire. The device is operated in much the same manner as an automatic sprinkler.

When the temperature in the stables rises to a certain point a weight is released which falls on a lever that in turn releases all the doors simultaneously. At the same instant certain noises are made mechanically which will frighten the horses from their places. The releasing lever is occasionally operated by hand to give the horses a fire drill. Each horse soon learns to trot from its stall when the door opens and the alarm sounds.

Greater Garage Service for Electric Cars

By Harry Salvat*

We all know that the electric car is more nearly fool-proof than the gasoline car and is unquestionably the vehicle for city use. Plenty of proof can be offered to substantiate this claim. The fact being conceded—why is it that we do not have more electric cars, both passenger and commercial, on our streets? It is the judgment of the writer that one of the principal reasons is that manufacturers are making no effort to cultivate and hold the best business “boosters” they can hope to have, namely, the public garages.

It might surprise you to learn that there are not more than three garages in the city of Chicago taking care of electric cars that are friendly toward them. Why? Simply because the manufacturers' representative knocks them every opportunity he gets with the very natural result that the garage man only takes care of an electric car until such time as he can replace it with a gasoline car.

Very recently I called at a garage where about 30 electric cars and 40 gasoline cars are garaged. While I was there the owner of an electric car came in and a conversation with the garage owner ran as follows:

Customer: “Hello, Ed. A nice day.”

Garage Owner: “Yes. Splendid for a trip in the country. Why don't you sell your ‘juice-box’ and buy a nice touring car?”

I was greatly surprised. The electric car owner left the garage feeling as if he probably were foolish for not procuring a gas car in which he could enjoy long country runs. After he departed, I asked the garageman why he had spoken to his customer in that manner and he replied: “Harry if I could trade all my electric boarders for gasoline cars, I would give three to one.” I asked what the trouble was and he stated that he made money on his gasoline cars on the sale of gasoline, oil, supplies, etc. Also, that if he had a gasoline car prospect and phoned some dealer in regard to it, or just gave the dealer the name of a prospective buyer and the dealer was fortunate enough to sell the party, he could always expect a check for being a good fellow and recommending that particular car. With the electrics it was an entirely different problem. With every electric car boarder he had, he stated he received a ticket to h— with it. I questioned him with reference to this and he then took me into his office and brought out a bunch of reports sent him by the electric car manufacturers which would stagger an elephant. Most of them were letters he had received after a car had been down to the manufacturer's for inspection and they read as follows: “Batteries sulphated; should have long over-charge.” “Not sufficiently charged.” “Grease cups not turned.” The fact is that although the car goes to the manufacturer once a month for inspection, for which the car owner pays \$3 a month, the grease cups would rust if they were not turned and filled by the garage man. Another report which is continually received and which is absolutely absurd reads as follows: “Tires not sufficiently inflated—right rear 80 pounds; left rear 70 pounds; right front 68 pounds and left front 72 pounds.”

As a matter of fact the tire companies only recommend 70 pounds all around and the garageman watches this pretty closely. However, imagine a lady receiving these reports monthly. She begins to believe that her car is

being ruined by the garageman when really these reports are so trivial that they are of no importance whatsoever. They merely irritate the car owner. Eventually, from various conversations with friends the lady finds out that those owning gasoline cars never receive any of these reports and she comes to the conclusion that these cars are receiving splendid care at their garage. The result is that she feels that her electric is too delicate and requires too much attention.

Further, the gasoline car manufacturers are boosting the garage men every chance they get as to the sale of supplies, etc. They even go so far as to advise their patrons to buy their gasoline from the garage owner and not to patronize the filling stations and tire brokers along the road.

However, with the electrics it is just the opposite. In my opinion the electric car manufacturers and dealers simply keep up this inspection system so as to be able to keep in continual touch with the cars they have sold; trying to keep the owner supplied with batteries, tires, etc., perpetually. In some instances where car owners are keeping their cars in a garage where all kinds of repairing, painting and supply work is being taken care of and the manufacturer has no chance to do business with him in that regard, the manufacturer when he gets a chance recommends some other garage to the car owner where no repairing is done or supplies are sold, feeling that by so doing the work will again come back to his (the manufacturer's) shop. Whether the owner's car is receiving the best of service and attention does not seem to interest him in the least.

If the garage owner should be fortunate enough to be able to sell one of his patrons a set of batteries or some tires, he never hears the end of the story because each and every time the car is sent down to be inspected by the manufacturer a report is made that the car rattles, the paint is cracking or the car runs slow; it runs either to the right or left, or, in fact, any way but what it should. These reports are kept up until the garage owner either loses the customer or the car owner trades in his old car.

You can readily see that when a car owner continually receives these reports and has to take them up with the garage owner, who, knowing where the trouble really lies, contradicts the reports of the manufacturer and argues with the customer trying to show where the reports are wrong; that the customer becomes quite discouraged with his car and the first thing you know he trades his electric for a gasoline car.

Now, then, what is the solution? First make every garage owner a friend of yours, cooperate with him every chance you get. Do not touch a battery or tire sale on a car that he is taking care of, as this is his business, not yours. If he makes good, you will do better. Remember, that if the electric garage man does not do well and is not successful, the manufacturer will go broke. The electric garage is the stomach for the food that you assimilate. If the stomach is in bad condition and not doing its work properly, you will look pale and not feel very strong. To improve it, you will have to find out where the trouble lies and see what your stomach can best digest. In other words, it is up to you, manufacturers, to wake up. Become friendly with the electric garage men and cooperate with them, then you will see that better conditions will prevail in the electric field. It is no more than natural to believe that as long as the electric garage man is not

*Extract of paper read before the National Electric Light Association convention in Chicago, May 22-26, 1916.

being treated properly by the manufacturers, he is not going to plug and work to help the electric vehicle business.

Every time an electric garage is put out of business or changes to a gasoline garage, it is one spoke broken in the wheel upon which the electric vehicle business rides. I know and you all know that there have been a great many spokes broken and I feel it is now up to us to get together and repair these broken spokes and get some new wheels for our good prosperous business.

The following will give you some idea of the work outlined for an electric garage man in taking care of an electric as compared with the work of a gasoline garage man:

The electric garage man receives a flat rate of either \$35 or \$40 per month for his cars; the late model cars are built with large batteries consuming a large amount of current; they have wire wheels; some of them carry an extra wheel which must be taken care of; the cars have three mats—a rubber mat, a fur mat and a mat to harmonize with the beautiful upholstery of the car. These mats must be taken out and cleaned every day and the way they are made up it is not the simplest matter in the world to replace them. If you happen to have a new man on the job, it is almost necessary to have a blue-print made up for him with directions showing how they are to be put in the cars until he becomes familiar with the work. The mat must be placed around two drives in the car; two revolving seats; two foot brakes; meter buttons and exhilarator buttons. Then he must see that the wheels on the car are tight and in good order; that the tires are pumped up to 85 pounds and then make sure of it. This must be done for two reasons: if he has 20 or 30 cars with tire pressure low, it means that the cars will pull two or three more amperes of current and if he runs along that way from month to month he will find that his profits are going to the power company.

Then we must deliver the cars anywhere from $\frac{1}{2}$ mile to $3\frac{1}{2}$ miles and get there as quickly as possible after being notified. No damage must be done; no mud splashes put on the fenders and then if you are lucky enough to reach the house about 8:30 or so you can take the children to school if you please, or take Mr. Jones or Mr. Smith to the elevated train. It will take only about ten minutes or so. The hiker has nothing to do anyway but wait for calls, so Mr. Jones may just as well make use of him as not while he has a chance.

On about 25 per cent of our deliveries we give the hikers car fare for the return trip. Otherwise, you will find them examining all the store fronts along the street as they return. That takes care of the morning delivery. In the evening after the car has undoubtedly been used most of the day and done some good hard running, it is most likely that the owner would like to take a small run either to the theatre or probably to play a little game of pinochle, say, about five miles or so from home; the car will make this run easily, but the owner wants to feel safe. The garage man, therefore, gets a nice telephone call asking him to please send for the car, give it a little boost and return it to the house in about an hour or so. It is necessary that we again call for the car, paying another car fare, taking chances of damaging the car. After the car comes in it must be put on charge (and it is usually during the peak hours and, believe me, it hurts to have to pay \$15 a kilowatt for current consumed be-

tween 4:30 and 8:30) and then we must redeliver the car.

Then another thing. The ladies take their cars down town and leave them in front of stores in the shopping district where it is necessary that they be moved every half hour. They instruct the doormen at the stores to watch the cars for them and move them when necessary. Very often in so doing the cars are bumped, bending fenders, breaking head and tail light glasses, etc. Of course, the owner does not inspect the car upon her return and does not know whether or not any damage has been done. Consequently, when the garage notifies the owner that repairs are necessary she knows nothing about it and complains that the damage must have been done in the garage or by our man delivering or calling for the car. No argument can convince her that we are not to blame and the consequences are that we must make the repairs without being able to charge for it.

Ninety per cent of the electric garages which have gone out of the electric business were forced out simply because they could get no support from the manufacturers. These men who are switching from electric to gasoline are not going to do the electric business any good as you can readily see, for, naturally, they are going to talk and push gasoline cars as long as they are going to handle them.

It is entirely up to the manufacturers to regulate these conditions. Their contracts with their agents should stipulate that tires, batteries, etc., should not be handled or sold by them to car owners who keep their cars in public garages. Also that if the garages do not happen to handle supplies of any kind, a tire or battery sold should be billed through said garage so that in that way the garage man could make his share of the profit just the same.

I feel sure that if you manufacturers will get together and do this you will release the brakes on progress and will find that the electric car will get its share of the business.

I think you will also find that this will eliminate a great deal of trouble for the car owner on adjustments of tires and batteries. He can deal simply with one party and not have to go from the dealer to the garage man and the garage man to the dealer.

The battery guarantees the dealers are giving are unreasonable and naturally invite trouble. They actually remind me of the faker selling on the corner, "Now you see and now you don't see." The idea of giving a car owner a guarantee on a battery which you know cannot be fulfilled and simply have the idea in mind of beating someone else is outrageous.

Now, gentlemen, this is not an article on engineering or improving of electric cars, simply an appeal to you for the future of the electric vehicle business by which means I and a great many of you are earning a living.

We have the goods to sell and the people want them, only we don't seem to know how to feed the "goose that lays the golden egg" and, believe me, the garage is the goose that lays the golden egg for the manufacturers.

It is a lucky thing for the electric garage men in Chicago that the manufacturers and dealers are not politicians. If they were they would surely revoke our licenses to sell parts or accessories of any kind.

One manufacturer went so far as to say that all the garage men should do to the electric car was to wash the mud off its wheels. If this only were done by the garage

men. as per this suggestion, I would like to see where the electric business in Chicago would be at the end of six or eight months.

As stated previously, compare the service given an electric car to that given a gasoline car:

Electric	Gasoline
Storage	Wash car
Charge	Polish
Wash	Store
Polish	Clean
Clean	
Call for and deliver	
Flush battery	
Oil	
Keep wheels in line	
Turn grease cups (at least every 3 days)	
Look after brushes and controller contacts	
Inflate tires	
Furnish drivers when desired	
Keep record on battery so it will not get shorted	
Carry liability insurance while cars are being delivered and called for	
Carry property damage insurance	
Keep skid-chains repaired	
Keep charcoal heaters going	
Pay car fares on deliveries of cars	
Then last, but not least, the electric garage man must have a special claim agent to adjust difficulties which arise between the garage man, manufacturer and car owner	

The gasoline garage man gets \$35 per month for his largest limousine. Thirty dollars on a seven-passenger touring car, without windows—simply a wind-shield to be washed. Twenty-five dollars a month for small touring cars without hardly any cleaning or polishing.

The electric garage man gets either \$35 or \$40 on his cars. However, the electric garage man must furnish the power while the gasoline garage man does not, and makes a profit of from two to three cents a gallon on his gasoline and about 30 cents a gallon on the sale of oil.

The gasoline man gets paid for every little thing done on the car, such as turning grease cups, changing tires, etc. Also, if the gas car owner needs a tire, spark plug, fender or some similar part he gets it through the garage man. It is not so with the electric car with a long guarantee tied to it.

Why it is that the Ford, Overland and similar large automobile companies have been so successful? Simply because they have given all the garage men an opportunity to make a profit on the sale of their cars, so that they all become boosters for their particular cars. This, however, is not done in the electric car game.

Now, gentlemen, I do not want any of you to feel that this is meant for any one manufacturer in particular. It is simply a layout of the true conditions in Chicago and I feel it ought to be looked into.

Meeting of Sterling Lace Creditors

The first meeting of creditors of Sterling Lace Leather Co., Inc., of Buffalo, N. Y., was held at the Bankruptcy Court Room, No. 410 Federal Building, Buffalo, June 19, at 11 o'clock a. m., to prove their claims, appoint a trustee, and examine the bankrupt. The Sterling Lace Leather Co. was adjudicated bankrupt May 22 last.

Movement to Restore Driveways to Horse-Drawn Vehicles

In the statewide movement for "good roads" that are good for horses as well as motor vehicles, horse owners and automobilists in New York City are joining hands to provide a place for driving horses in Central Park.

It is purposed to construct a new drive exclusively for automobiles as near as possible to the outside walls of the park, avoiding all grade crossings, and then restore the east and west driveways, together with some of the transverse roads, to their original use for horse-drawn pleasure vehicles and riding horses.

The movement originated with the Mayor's Central Committee on Street Traffic and Safety. This committee recently passed a resolution approving the project just outlined, and at the last meeting of the Citizens' Street Traffic Committee, held at the Automobile Club of America, this solution of the park problem received the further indorsement of that general committee, the secretary of which is Elmer Thompson, also secretary of the Automobile Club. The resolutions were incorporated in a letter to Arthur Woods, Commissioner of Police, who has turned the matter of the resolution over to the Commissioner of Parks, Cabot Ward, who is said to be heartily in favor of the project, though in doubt about the possibility of carrying it out. Mr. Ward, it is understood, recognizes the fact that the advent of motor vehicles has not only made it next to impossible to drive horses with safety in the park, but has greatly increased the perils of pedestrians, and particularly women and children, in crossing the present automobile driveways to reach the recreation grounds.

With Mr. Thompson, secretary of the Automobile Club, and Mr. Taylor, who as editor of the Rider and Driver, represents the horse interests, working hand in hand with the city officials to restore some of the park drives to the carriages, there is believed to be more than a fair chance of success. The drives were one of the sights of New York every afternoon during the driving season before the harness and saddle horses were forced off the roads. No horse show in the world presented such an array of sumptuous equipages, many of them drawn by splendid pairs that were champions of the show ring. Thousands of pedestrians used to throng the sidewalks along the fashionable east drive to see this daily promenade on wheels. Notable men and beautiful women of society in the carriages added to the splendor of the pageant, which was celebrated all over the world.

Goodrich vs. Firestone Trade-Mark Suit

The B. F. Goodrich Co. has won the first round in the controversy over black tread tires by a decision just handed down in the U. S. Patent Office. An application by the Firestone Tire & Rubber Co., for registration of a black tread band and red sides as a trade-mark was opposed by the Goodrich Co., which claims to possess trade-mark rights in a black tread band used with sides of any contrasting color, especially light gray and white, and also claims to have used the specific combination of black and red on pneumatic tires prior to the earliest date of adoption by the Firestone Co. The Examiner of Interference denied a motion by the latter concern to dismiss the Goodrich opposition.

Senate Aroused to Need of Horses

Senator Key Pittman, of Nevada, who is sponsor for the bill recently introduced in the Senate calling for an appropriation of \$200,000 for the purchase and maintenance of stallions to be used in the production of horses for agricultural and military purposes, had the following to say in discussing the measure which has been referred to the Committee on Agriculture and Forestry, of which Senator Gore, of Oklahoma, is chairman.

"I was actuated in the introduction of the bill by a knowledge of conditions in my own state, where we once had an abundance of horses of an enduring type. Within the past 18 months buyers, both local and foreign, have taken many thousands of head of the very sort of animal we require for such campaigns as we are now prosecuting in Mexico, and where with only a small force of cavalry in operation the remount situation is acute. Realizing that the geographical position of my state and the high freight rates would make it one of the last to receive the attention of the representatives of foreign governments I thought it was imperative that something be done to repair a damage which must be nation-wide.

"This belief was strengthened upon investigation," continued Senator Pittman. "General Aleshire, the Quartermaster-General of the United States, testified before the Committee on Military Affairs recently that not more than 250,000 horses of the cavalry remount and light artillery types are available for the uses of our government at the present time, and that of this number 30,000 are in that condition where they could be pressed into immediate service. These figures were obtained by a special census taken in districts where the government remount stations are situated and they furnish every American a grave subject of consideration. With purchasing campaigns still being prosecuted the supply must be lower today. Statistics at hand indicate that we have lost since the commencement of the Continental war approximately 1,500,000 horses and mules, and it is high time that we set about replenishing these.

"There is no element of preparedness of more vital necessity than the army horse, and especially along our southern border, where he is absolutely essential. In the east, where good roads exist, he does not dominate the situation to the same extent as in the south and south-west, but it is a generally recognized fact the world over that the army of no country is stronger than its cavalry and light artillery horse equipment. We have failed hitherto to give this animal the important position accorded him by the Old World nations, but it is all the more reason for a prompt and satisfying adjustment of this problem which carries a powerful economic appeal to the country at large."

A Lamp Glass Dimmer

When unexpectedly coming into an area of restricted lighting, lamp glasses can be quite effectively dimmed by the following method. Carry on the car a little tin of metal polishing paste; a small quantity of this paste should be smeared on a damp cloth and rubbed over the inside of the glass. It will dry in a few seconds and produces quite a good opalescent effect. When no longer required, it can be removed, just as easily, with a dry cloth.

Automobilists Do Not Want the New York Speedway

The Horse World publishes a communication from R. O. Currie, of New York, as follows:

It may be of interest to the public to know that the effort now being made at Albany to turn the New York speedway over to the automobilists does not come from the organizations representing that interest. The governors of the Automobile Club of America, the largest and most representative organization of its kind in this country, at a meeting on April 14 passed a resolution to the effect that it has never made any effort to use that little strip of ground, does not want it, and, on the other hand, considers it entirely reasonable and fair that it should be preserved for the horse.

The public has often been told that a few people are using the speedway and that it is drawing less and less every year, which are entirely the reverse of true. As a matter of fact, there were more horses on the speedway during 1915, and more people there to see them than during any other year since the drive was opened.

Commencing May 9 and ending November 21, there were 22 matinees, with an average of 10 brushes each day, and on some days 14, with from two to eight horses contesting in each brush.

As secretary of the Road Drivers' Association of New York City, I am sending you these facts in order that we may get a square deal. The speedway is the only spot in Manhattan where a man who loves a horse can drive him with safety. There are many hundreds of such horses in New York City. There has been too much published about the speedway which is not true. The automobile has every street and park in the city. May we not retain this little spot?

Bock Bearing Company Reorganized

The plant of the Bock Bearing Co. on Phillips avenue Toledo, O., has been taken over by a new corporation having a capital of \$1,650,000. The new company was incorporated recently under the name of the Bock Taper Roller Bearing Co. Of the stock issued by the new corporation, \$1,200,000 will be common and \$450,000 will be 7 per cent cumulative preferred. Holders of old stock will exchange share for share of new stock, and old preferred will receive two shares of new common for one of preferred. The capacity of the plant will be tripled, giving an output of 3,000 bearings daily.

The following officers have been elected: President, W. E. Bock; vice-president, Eugent Rheinfrank; secretary and treasurer, C. H. Clement. The officers, with M. H. Murch, of Cleveland, and J. E. Duniplace, of Toledo, comprise the directorate.

Horse and Mule Exports

Our exports of horses and mules in 1914 amounted to \$4,000,000 in value, while in 1915 the total amounted to \$77,000,000. While this was a great gain in foreign sales, the total number exported (355,000) for 1915 represents about 1½ per cent of the supply in the United States, and was not sufficient to prevent a decline of about 4.6 per cent in the average price. The low price is partly due to inferior quality. Good horses will continue to bring good prices.

Wheels and the Cinematograph

Why Wheels Appear to Rotate Backward or Remain Stationary on the Screen

Most everyone at some time or another has seen the hero of a cinematograph film driving furiously in pursuit of the villain, while the wheels of both cars solemnly remain stationary or rotate backward, so destroying the illusion of speed.

This is noticeable not only in pictures of cars but in those of guns or any other wheeled vehicle moving at a certain speed, and to understand the phenomenon one must have some idea of the camera mechanism used to take these pictures. Broadly speaking, and without at-

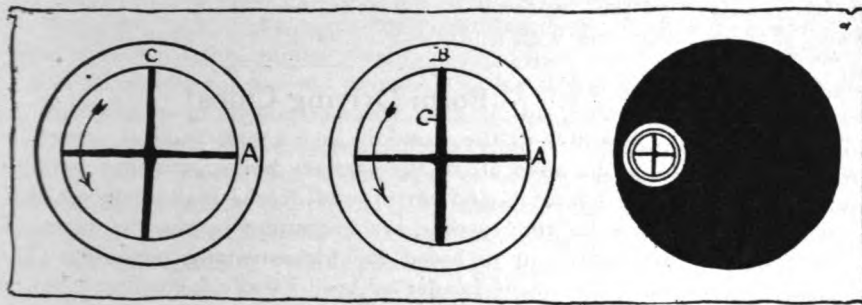

Fig. 1—A diagram of a wheel and cinematograph shutter showing how the wheel may appear stationary

tempting to go into details, says Light Car, the cinematograph camera can be regarded as a machine which takes a series of separate photographs, and is parallel with an ordinary camera, in which there is a constant succession of plates exposed one after the other by a man who removes and replaces a cap over the lens very rapidly. Thus the pictures are not taken as a continuous stream but in a series of jerks, each picture being exposed exactly as though it were a single plate. To do this, imagine a disc rotating in front of the lens, and having a series of holes drilled in it, very like the chambers of a revolver. As each hole comes opposite to the lens the film is exposed, then the interval between that hole and the next cuts off the lens's view while another piece of film moves up to be exposed by the following hole. Thus we have a succession of pictures which, thrown on a screen by a similar mechanism, would give a series of pictures of an object moving in jerks, for the lantern has a similar disc to cut off the lens while the next picture moves into position. Actually, this cut off is a bare flicker on the screen.

Taking the Photograph

The mechanism of the camera being actuated by hand, its speed can vary, and it is easy to imagine that, should the operator desire, a photograph might be taken of a car at 40 miles per hour, then the lens cut off, and several seconds later the next exposure made. As the car would have moved some distance between the exposures a very jerky film would be recorded.

Now, in taking a picture of a car the camera handle may be rotated at a steady speed, but as the car picks up the spokes of the wheel go faster. Therefore, the space over which these spokes travel in the interval between picture and picture varies all the time.

Imagine now a four-spoke wheel similar to that shown in Fig. 1 on the left-hand side, and suppose that between you and it there is a large disc with one hole in it as shown on the extreme right. Now the eye is the lens, and is fitted with a screen, so should some one rotate the wheel while the disc revolves slowly you will get a glimpse of the wheel every time the hole in the disc comes opposite your eye.

Spoke Movement

Now suppose that the speed of the wheel relative to the disc is such that the spoke A in the center picture has moved from A to B—that is to say, occupies now the place previously occupied by spoke C, and that in this time the disc has gone round once. The first glimpse will show a wheel in the position shown in the left-hand view; the next glimpse, however, will show it exactly the same even though spoke A now is where spoke C was. Therefore, the wheel would not appear to have moved at all because one has no means of distinguishing one spoke from another. Were they lettered all you would see would be that the wheel was the same, but the letter for some reason had moved one spoke around. Now, it does not matter how many spokes there are, or how many

holes in the disc, for if one spoke moves from its original position a distance equal to the distance between spoke and spoke in the interval between the glimpses of that wheel then to the beholder the wheel is stationary. This is why wheels often appear stationary, yet the car, obviously, is going fast.

Now, for purposes of explanation, take a single spoked wheel, as in Fig. 2 on the left hand again. If this spoke has moved one complete circle between glimpses, then the wheel appears stationary; but suppose that one gets one's first glimpse of the spoke at A, and then rotates the disc in front of the eye rather faster, obviously the spoke will not have completed a revolution when the disc aperture again comes opposite the eye. Therefore, the spoke

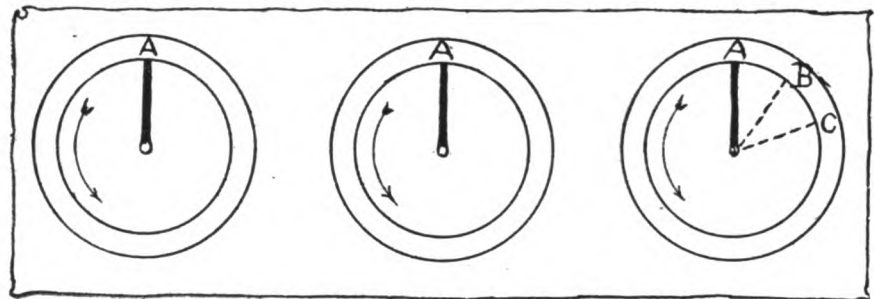

Fig. 2—A diagram to explain how the wheel appears to travel backwards on the screen

will be in the position shown in dotted lines B.

The Backward Motion

Now a funny thing has happened, for, although the wheel is rotating in the direction of the arrow, the spoke is seen at A first of all, and afterward at the dotted line B; in other words, further back than it was before. Continuing to rotate the disc at this speed, one will see that one's third glimpse of the spoke will be at the dotted line C, or further back still. Then, as far as the eye can tell,

the wheel is traveling backwards, since the spoke is seen further back each time.

Again, it does not matter how many spokes there are, or how many apertures in the disc, if the speed of the disc is the greater in relation to the speed of the wheel, then that wheel appears to revolve backward. Naturally, if the disc revolves faster than the wheel, then the spokes appear to revolve forward. Obviously, the wheel could produce either effect if it is traveling at a varying speed relative to the steady revolutions of the camera.

Predicts Big Attendance at C. B. N. A. Convention

R. E. Logsdon, publicity agent of the Cincinnati Chamber of Commerce, says:

"Manufacturing conditions in the vehicle industry at Cincinnati, according to confidential reports received by the Cincinnati Chamber of Commerce, are above normal. Compared with the same period last year the increase is remarkable. The supply of skilled labor in connection with this industry is considered short. There are many circumstances which go to make up these conditions, but it is reasonable to believe that there has been a marked improvement in the vehicle industry, and the market tone is firm with a prospect of continued good business for an indefinite period. This is cheering news to members of the Carriage Builders' National Association, Enamel Leather Manufacturers' Association, and the Harness and Accessory Traveling Salesmen. It is usual to refer to such a marked increase in business as a "revival," but many Cincinnati people are inclined to believe that progress in the industry as evidenced by reports similar to the above indicates a steady advance rather than a revival. For this reason it is predicted that the convention of carriage builders at Cincinnati, September 25-30, will be larger than for many years, and that the discussions at this meeting will result in a rejuvenation of old markets and the discovery of new ones by the carriage people."

High Class Auto Plant for Philadelphia

A new auto manufacturing company to build a high class automobile has been incorporated for half a million dollars in Philadelphia. The capital is all paid in. The company will be known as the S. S. E. Co. and is composed of New York and Chicago capitalists. Ground has been purchased in the vicinity of the Hess-Bright plant in Kensington on which a large plant will be built.

The officials of the company are: Victor Lee Emerson, designer of the Emerson engine, formerly president of the Emerson Marine Engine Co., and holder of a number of patents covering gasoline engines; E. E. Smathers, a New York capitalist of prominence, and C. B. Shaeffer, of Chicago, and head of the Shaeffer-Smathers Oil Co. Mr. Emerson is general manager. Mr. Smathers president, and Mr. Shaeffer vice-president. Temporary offices have been opened at Twenty-third and Chestnut streets.

The buildings and equipment will cost close to \$1,000,000 in addition to \$250,000 already spent in getting the enterprise under way. The company owns and controls its own patents and will make everything going into the finished car except the tire and electrical equipment. Mr. Emerson estimates the value of the first year's output at \$5,000,000.

The plant will be located on a piece of ground having

a frontage of 2,000 feet on the main line of the Pennsylvania Railroad. It will cover approximately 20 acres. The buildings will be of concrete and steel and one story high under a saw-tooth roof. The equipment will be along most modern lines and will be electrically operated throughout.

It is claimed that the car will be the highest priced of any made either in this country or in Europe. The chassis alone will cost in excess of \$5,000. The body will be made in a number of styles and will be both open and closed.

None but the highest grade of workmanship and material will be used and the main idea will be to turn out a highly scientific and flawless car regardless of price. Two of the principal features will be nimbleness and lightness. So pronounced is the latter feature that it will move while standing with a pressure of hardly more than 3 lbs.

Form Driving Clubs!

A writer in the London Live Stock Journal, which is a strong advocate of the hackney horse, says that judging from editorials and correspondence he really believes that some hackney people are beginning to see the futility of trying to run a breed for high-stepping purposes. He adds that in the Leader of April 7 is the following: "Fancy work is not going to keep the breed alive." Another writer, he quotes, says: "We ought to judge on easy and graceful action." Certainly, he continues, that is just where the trotter excels, or he could not trot so fast. The hackney was intended to be a driving horse. Then why not drive him? Why not have the driving clubs and prove that there is still an interest in driving? Making excuses about motors and the roads by people who only own hackneys for show will not keep the breed alive. There are more motors in North America than any other part of the globe, but still that does not prevent the existence of several hundred driving clubs. In some small towns in the States there are from 100 to 300 members of these clubs. Now is the time for all horse lovers to show that they are sincere, and to use their horses on the road. This will give encouragement to others. Everybody who loves a horse cannot find time or money to keep race horses or go hunting, therefore he must get his bit of sport on the road; but so long as we keep harness horses only for "fancy work," then we can expect no consideration from the Road Board. Rider and Driver suggests that members of the American Hackney Horse Society, each in his own town or neighborhood, organize a driving club, and believes the sport of driving not only light harness roadsters but gigs, pair-horse phaetons, tandems and coaches would rapidly increase. The so-called dangers of the motor car and the hard and slippery roads are much exaggerated and could be overcome and regulated.

England Buys Plant Site

The England Mfg. Co., Detroit, Mich., making a specialty of pressed steel door panels for automobiles, and at present located in a factory at Jefferson and Campbell streets, has acquired a three-acre factory site adjoining the plants of the Federal Motor Truck Co., and contemplates building a plant comprising 54,000 sq. ft. of floor space to enlarge its business in its specialty. The plant is to be ready for occupancy in 60 days.

Evolution of the Vehicle

When one consults authorities in an effort to learn something of the history of vehicles used by man, he is led far into the past.

"Probably," states one authority—and one regarded as authentic—"the first instrument used for drawing burdens was the sledge."

This, of course, has no reference to burdens on the backs of beasts—a method that was employed, perhaps, by Adam and his immediate descendants. One finds sledges pictured upon the monuments of ancient Egypt. A little later, when the Egyptians began employing huge blocks of stone in their monuments and pyramid-building operations, rollers of wood were used.

The next natural step was the substitution of wheels, cut in solid pieces from large logs, for rollers. And in a little while, no doubt, came the substitution of wheels with spokes for the clumsy, solid wheels.

Use of vehicles drawn by animals was introduced, it is thought, soon after the domestication of the horse and ox. From that period improvements were made from time to time. During the middle ages vehicles were slung on wooden strips to lessen the jar. Steel springs were not introduced until about 1700, and the elliptical spring was invented in 1804. While hackney coaches, so called, first plied for hire in London as early as 1605, their use did not become general for a long time. And long after they made their appearance upon the streets of cities, the older and generally employed horse litter continued to convey passengers from point to point in the country and from city to city.

For centuries the horse litter had been used as a hired carriage by those unable to maintain separate conveyances for themselves. As late as 1680 it was to be seen upon the streets of English cities and upon English highways. One of the last references to the horse litter was made in 1680, when an accident to General Shippen was recounted: "He came in a horse litter wounded to London; when he paused by the brewhouse, in St. John street, a mastiff attacked the horses, and he was tossed like a dog in a blanket."

Many a fair maid and bustling matron of those long-gone days made journeys of considerable length in the horse litter, either their own or hired for the trip. It was not a very comfortable sort of conveyance, one surmises, but it was better—at least, more dignified—than walking, and was in great favor with women who, for any reason, did not care to ride horseback and with gouty old gentlemen, who found themselves less tortured by it than by the rougher exercise of the horse and the saddle.

It is generally understood that the sedan chair was born in Sedan, France; hence its name. Just when this introduction of a new method of conveyance was made is not stated, but the sedan chair was popular throughout Europe for many generations; it was especially the polite mode of conveyance in England long after the hackney coach had made its appearance. Great numbers of these chairs were always available for immediate use, and numerous old engravings and pictures show every phase of their service. They were very popular with ladies—in fact, were considered almost indispensable in fashionable circles—and they were used extensively by men as well.

One of Hogarth's famous prints in *The Rake's Progress* shows the young dandy just alighting from a sedan chair and being arrested for debt. Nothing perhaps, fitted bet-

ter into the romantic demands of the novelist engaged in depicting the social life of past generations than did the sedan chair. There was a romance in itself about this richly upholstered and man-borne conveyance of the ladies and dandies of ages agone. One can imagine the fine women of the period, in their silks and brocades, being conveyed to fashionable events by liveried chair-bearers—who became coachmen and footmen in later years, when wheeled vehicles supplanted the chair.

In 1634 Sir Francis Duncomb obtained letters patent allowing him to let "covered chairs"—sedan chairs—for hire for fourteen years. It is not known whether he made a success of this early attempt at monopoly, for, even at that time, hackney coaches had become numerous. At first these had not been allowed to stand in the street, but had to remain in the owners' yards until called for. Their owners and drivers must have manifested some latter-day propensity for getting around such regulations, however.

By 1653 these coaches had increased to such numbers that King Charles I. issued a proclamation, stating that the "general and promiscuous use of hackney coaches in great numbers cause disturbance to the king and queen personally, to the nobility and others of place and degree; they pester the streets, break up the pavement and cause increase in the price of forage."

In the annals of old London one finds that carriages were first "driven at a rapid pace" in 1654, and also, that in 1662 hackney coaches were forbidden to ply for hire on Sundays. Statistics show that there were 2,490 hackney coaches in London in 1662, but the number of horse litters and sedan chairs is not stated. About that time the horse litter was approaching the end of its career, and the sedan chair was coming into favor.

With the increasing popularity of the wheeled vehicle the carriage makers' art advanced. The eighteenth century post chaise was often very elegant in its appointments, and, perhaps as a rule, not so slender in its important parts as indicated by many drawings that pictured it. Very elegant, too, were many of the substantially-built road coaches constructed for the country gentlemen of America. While the saddle horse was the favorite mode of conveyance of the men, they used the coaches frequently for long journeys, and there were often special coaches for the women of the family.

Indeed, the historical romances that began cropping out in such numbers some years ago would have missed some of their most picturesque features had it not been for the family coach, with the grinning negro driver on the seat, and the fair passengers, decked in furbelows and laces, on their way from plantation to plantation to attend some fashionable function of the day.

Most of us, perhaps, are under the impression that the automobile is entirely the product of latter-day genius; that the swiftly gliding vehicle is among the latest of modern inventions. And yet there is on record in the United States patent office, under date of October 17, 1789, a patent granted for a steam automobile, only it was called a "self-propelled carriage."

Earliest patents for self-propelled carriages or wagons covered devices that relied upon springs as the motive power, something upon the principle of a watch. In due time, however, and in order, came the steam-propelled vehicle, the gas carriage, the air carriage and the electric wagon.

Wonderment was evoked by the first successful auto-

mobiles, and yet they are now as firmly fixed in the order of our daily life as are the skyscrapers of the city. One reason for their popularity is because they have appealed especially to the heart of woman—and woman's favor rules the inanimate, as well as the animate world.

So it does not seem such a far cry, in view of recent developments, to the airship as a popular and general means of travel. Many a young miss now devoting her days to the polishing processes of the boarding school, may own her airship in the days to come, just as her mother now calls for her automobile when she wishes to go shopping or pay a round of social calls.

Starting a Balky Horse

Of all vices that equine flesh is heir to, the most annoying to the average horse owner and driver is balking, or near balking, which consists in rearing or plunging when first asked to start, particularly after a few days' rest, or what is still worse, trying to start with a jump when only half hitched. The main reason that I think it is so aggravating, writes Alfred H. Pope, in *Dumb Animals*, is that so few know how to combat it. A balky horse has the most sense, the confirmed runaway the least, of any horse.

I have bought more balky horses than those with any other vice for that reason. Once they are broken of balking, they make the best of horses, not afraid of the objects that usually scare those of other temperaments.

The little simple trick I am going to describe and that has proved so satisfactory in so many cases is not intended to break the horse of balking, which in most cases involves a lot of time, patience, and more or less thorough knowledge of horse nature, but rather to help those who have been caught, perhaps with a new horse that started away from home all right but has now balked, because the conditions under which he has balked before have again presented themselves.

The average driver, when caught in this way, starts in by petting and coaxing the horse and winds up by losing his temper and beating it until stopped by passersby or some policeman.

A horse has only one idea in his head at a time, and in this case he has decided not to go any further with that particular load, and the coaxing and petting are not sufficient to cause him to think of anything else. The whipping only makes him more stubborn and determined not to move. Now we have got to find something that will give him something else to think about.

All horses, and mules more so than horses, hate to have their ears hampered. In fact no horse ever decides upon a different course of action without first moving his ears from the normal position, and here is the key to the whole idea. As soon as it balks get down from the seat and deliberately take one ear and push it under the crown piece of the bridle so that it is fast and leave the horse to its own devices for a few minutes. He will commence shaking his head and doing everything he can think of to get that ear loose, until he has forgotten all about balking and his whole thoughts are centered upon freeing that ear. Now let the driver get back on the wagon, call on the horse to start, and off he goes. I have proved this trick to be successful with cow-horses that thought it necessary to buck and pitch when first mounted in the morning, and with rearers in the saddle and horses hard to hitch. Leave the ear where it is for about 20 minutes, then stop and free it. Let the horse have time to shake

his head and be satisfied that everything is all right again, and off he will go as pleasantly as possible.

As I said before, this trick will not break a horse from balking, but it will invariably start one that has balked on the road, provided he hasn't already been whipped and abused to a point where nothing matters.

Put Humor in Your Advertising

When the dealer prepares to write an advertisement designed for publication during the summer months, he should carefully consider a few important essentials. The most important consideration is good nature on his part. He should remember that he cannot compel customers to come to his store; he must win them. As every dealer knows, more flies are caught with molasses than with vinegar. It is equally true that more customers are won through a good natured advertisement than through a message which "hurls" stern facts at their heads. A little consideration will convince anyone that it isn't uncommon for the dealer to become serious and morbid during a hot spell of weather. Now, if a person writes an advertisement when he feels this way, and allows his feelings to direct the message, the result will be an arrogant, domineering message which will do more harm than good. All the advertiser's art should be directed to making his advertising messages so pleasant that the majority of the citizens who read them will be attracted and won over to his line of reasoning. It is fortunate that humor can be cultivated. Humor is one of the most important things in the whole art of advertising, and we do not exaggerate when we say a good humorous advertisement is worth its weight in gold!

We have no space to devote to a discussion of what humor really is; we must confine our remarks to a summary of the results which may be expected through the introduction of humor in the dealer's advertising campaign. Before the dealer can write a really humorous advertisement, he must understand the facts he desires to present in a thoroughly delicate way. Humor offers the advertiser greater assistance, because its introduction prevents him from straying from what is natural and normal. Humor appeals to the reader on his weakest side. There are not five men in one hundred who have cultivated a resistance against humor. The humorous advertiser immediately gets on good terms with the public, and each individual will listen to him while he states his reasons why it will pay all citizens to trade at his store.

A little thought will convince the dealer that humor has a beneficial effect upon his own nature, as well as that of his customers. When the dealer shows occasionally symptoms of humor his customers are certain that he is good-natured, is determined to be agreeable, and is honest. The dealer with this kind of a reputation is pretty apt to be successful.

Will Not Take Used Cars as Part Payment

The dealers of Fort Wayne, Ind., all of whom are members of the Auto Trade Association, have decided not to accept used cars as part payment for new machines. Heretofore they have allowed owners of old cars varying sums to apply on the purchase price of a new car, but hereafter the terms for a new car will be cash. The old car may be left with the dealer, however, and he will try to dispose of it.

Pivotal Point of Labor Union

An Influence for Good When Properly Directed—Danger of Unlimited Power

Every great and excellent thing in the world has had to fight for its right to live. The building up of any and every beneficent institution, commercial, artistic, educational, has been a struggle against misunderstanding, inertia, and stupidity. Men often fight against a thing because they are not ripe for its acceptance. As a close observer of men and an employer of labor for over 35 years, I feel that I am particularly apt to treat the subject in hand with absolute impartiality, especially at this time, when ill health has relegated me to the retired list and I have no axes to grind either way.

I remember reading some 25 years ago, that an engineer on a fast passenger train became violently insane. The time on his run had been cut down to 50 miles an hour. It was very rapid running at that time and it told severely on the man's nerves. Suddenly while at the throttle reason gave way and the engineer started to make a record run. He imagined there was another fast train just behind; his life was at stake and safety for himself and his train demanded that he should make 100 miles an hour. He had nearly attained his pace and was flying past a station where he should have stopped for orders, when the fireman, realizing the situation, laid the mad engineer low with a link-pin and the train was slowed down just in time to escape wreck.

There is a natural law well recognized and defined by men who think, called Law of Diminishing Returns, sometimes referred to as the Law of Pivotal Points. A man starts in to take systematic exercises, and he finds that his strength increases. He takes more exercise and keeps on until he gets "stale"—that is, he becomes sore and lame. He has passed the Pivotal Point and is getting a diminishing return. In running a railroad engine a certain amount of coal is required to pull a train of given weight a mile, say, at the rate of 50 miles an hour. You double the amount of your coal, and simple folks might say you double your speed but railroad men know better. The double amount of coal will give you only about 60 miles instead of 50 with a heavy train. Increase your coal and from this on you get a Diminishing Return. If you insist on 80 miles an hour you get your speed at a terrific cost and a terrible risk.

Another case: Your body requires a certain amount of food—the body is an engine; food is fuel; life is combustion. Better the quality and quantity of your food and up to a certain point you increase your strength. Go on increasing it, and you reach a point where you get diminishing returns. Go on increasing your food and you get death.

Loan money at five per cent, and your investment is reasonably secure and safe. Loan money at ten per cent and you do not double the returns; on the contrary, you have taken on so much risk! Loan money at 20 per cent and you probably lose it; for the man who borrows at 20 per cent does not intend to pay if he can help it.

The Law of Diminishing Returns was what Oliver Wendell Holmes had in mind when he said: "Because I like a pinch of salt in my soup is no reason that I wish to be immersed in brine."

Labor unions well illustrate the Law of Diminishing Returns. Labor unions have increased wages, shortened

hours, introduced government factory inspection, have partially done away with child labor, and accomplished other useful, excellent and beautiful things. But when labor unions go beyond the Pivotal Point and attempt to dictate the amount of the output—prohibiting any men to earn more than so much; decide on the proportion of apprentices to workmen, that is, who shall advance and who not; declare what work shall be done in schools, in prisons and what not; tear out work that has been done by non-union men and require that it shall be done over by union men; insist that you must join a union, or else be deprived of the right to work; then the union has passed the Pivotal Point, and has ceased to give an equitable return.

When your children do not go to school for fear of the cry "scab"; when your wife dare not hang out the washing in the back yard for fear of the cry "scab"; when you hesitate to go to your work knowing you may be carried home on a shutter; when brickbats take the place of reason, and the walking delegate says: "Carry a union card or take out an accident policy," then things have gone so far that in self-protection the union must be temporarily laid low with a link-pin.

The people of America cannot afford to let any combination of men become an engine for the destruction of liberty. There are a million and a half men in America paying dues in labor unions. There are 8,000 paid walking delegates or business agents, who look to the laborers for support. A million dollars a year is paid to organizers, the money being paid by the laborers. Here we get an institution that supports a large number of men who do not work; who call a strike or declare it off; who can prey on both employe or employer at will.

Local unions meet weekly or daily. The men are called together to receive orders. Conference and consultation are out of the question—unions are run by the men who get paid for running them. And the talking men in any union are, almost without exception, men who hope to rise, by loyalty to the union and not by helping along their employer. Did you ever hear of a union where the men were called together to discuss methods and means to better the business that supplied them work? Not exactly!

Members of a union hope to rise by helping along the union. They want more pay, shorter hours, and give their time to stating grievances that grow by telling. They wish to become walking delegates, organizers or officers in the union. Men who are loyal to the firm, who have ambitions about furthering the business; who expect to become superintendents, foremen, partners and officers in the company, keep out of unions, because they are not wanted there.

Labor union organizers constantly fan the fallacy that employers are the enemies of the men to whom they supply work; that capital is at war with labor, and that success lies in secretly combining against capital. The organizers and helpers are really paid attorneys and their business is to distort the truth for their own interests.

Labor union meetings are all *ex parte*—only one side is represented. The employer, his superintendents and foremen are carefully excluded.

With the "open shop" the labor union is a good thing. It brings men together, and that which cements friendships and makes for brotherhood as well.

But the "closed shop" creates a sharp line of demarca-

tion between labor and capital, and between union and non-union men. It says, "Once a laborer always a laborer." It stops the law of evolution; throttles ambition; stifles endeavor; and tends to make tramps of steady and honest workingmen. Workingmen who own homes cannot afford to join unions, and men who are in unions cannot afford to invest in homes. Because to strike is not a matter of choice; they have to throw up their jobs at the crook of the finger of a man who, perhaps, has no home, no wife, no children, no aged parents. Men over 40 who go on strike do not get back. Strikes are ordered by young men who have no property interests, no family ties and nothing to lose. For old men who cannot earn the scale there is no work. Men with children to feed and clothe had better not forfeit the friendship of their employer by disregarding or opposing his interests.

When the unions have power to dictate a closed shop, they have reached a point where they say, "You must join our union or starve." When unionism reaches a point where it dictates to the employer whom he shall hire, and decides who shall have the right to labor and who not, then unionism has become un-American—a menace too great to overlook.

Unlimited power is always dangerous when centered in the hands of a few men. They undertake to manipulate and regulate the lives of those who toil, and take toll for their service. The result is, that being human, they are drunk-power-crazed by success, and are attempting to run an engine fitted for 50 miles an hour at a speed of 100. It is the working out of the Law of Diminishing Returns. From being a benefit, the labor union has become a burden. The few men who control the labor unions have created a phantom in their minds called "Capital," which they think is after them and is going to shunt them into the ditch. They have frightened the laborers so long with ghost stories that they have come to believe their lies. What shall be done about this insane clutch for power? Must we forever endure the rule of the demagogue?

Who is right in this question of "Labor versus Capital"? I'll tell you both sides are right and both sides are wrong. The capitalists of this country, for the most part were once workingmen, and many are workingmen now. And any laborer who owns a home and has a savings-bank account is a capitalist.

The open shop means liberty. The closed shop means slavery. Moreover, it means faction, feud, strife, violence. The open shop will make employers considerate, and labor unions cautious.

Employers are not base and grasping, any more than men who work for wages are truthful, trusting and intent on giving honest service. Men are men, and safety lies in the balance of power.—Chas. Scheuer, in *Trunks, Leather Goods and Umbrellas*.

Hayes to Make Wire Wheels

To meet the demand for wire wheels as well as the wood type, the Hayes Wheel Co., Jackson, Mich., has decided to manufacture the wire type along with its wood wheel production. General selling agent for the Hayes wire wheel will be the Castle & Kyte Co., 872 Woodward avenue, Detroit. The latter is a new organization, composed of F. E. Castle, well known in the trade as the head of the F. E. Castle Co., and H. W. Kyte, former assistant general manager of the Houk Mfg. Co., Buffalo.

Against Deferred Payments for Motor Vehicles

In view of certain advertisements which have appeared relative to buying motor cars on the deferred payment plan and the use of the names of certain cars without authorization from the manufacturers, the National Automobile Chamber of Commerce at its directors' meeting on May 3, voted to institute a broad and vigorous campaign of education, not alone among publishers, but among members of the N. A. C. C., calling attention to the fact that widespread advertising of credit plans is detrimental to the industry; that members be encouraged to avoid adopting policies which may undermine the business and that they be encouraged to pursue those policies which can alone maintain and continue permanent success. The resolution is as follows:

"Whereas certain influences are working and certain efforts are being made for the organization of plans which will have a disastrous undermining effect on the stability of the automobile industry, and

"Whereas it is the opinion of this committee that injurious results will follow the adoption of these methods by any considerable number of automobile manufacturers, and

"Whereas the methods of deferred payments under consideration are very objectionable from the factory standpoint, and are objectionable to a large degree from the dealers' standpoint, and have a disastrous effect on the purchasing public, which will unavoidably react injuriously, now, therefore, be it

"Resolved, That a broad and vigorous campaign of education be conducted by the National Chamber of Commerce, instructing and enlightening its membership along these lines and calling their attention to the fact that methods which on superficial consideration seem to have merit are in reality potent forces for destroying the foundation on which our industry has been builded, and that every effort be made to encourage the membership to avoid adopting policies which will undermine the stability of the industry and to encourage them to pursue and develop those policies which can alone maintain and continue permanent success."

It Is to Laugh

An exchange publishes a few instances of publicity errors which are decidedly amusing. For instance:

Sign in bakery window: "Home-made pize."

Card in restaurant: "Small steak, 20 cents. Extra small steak, 25 cents."

Advertisement in poultry journal: "Plymouth Rock hens ready to lay \$1.25 each."

From a prepared-roofing ad: "It's bright-red color is permanent and will remain permanent."

In report of a wedding: "The ceremony was performed by two Jewish rabbits."

A Milwaukee paper informs us that "John Huckbody of Wausau lost thirty chickens by freezing to death."

On a coupon: "The holder of this coupon when properly punched is entitled to one of our beautiful photographs."

An English report on education says: "The female teachers were instructed in plain cooking; they had, in fact, to go through the process of cooking themselves in turn."

Paint Shop

Points on Baking

By W. G. Scott

In many of the automobile factories, stamping works, toy shops, and other industries, where time is of vital importance and an extremely hard finish is desired, it is customary to bake the goods.

Two kinds of heat, dry and steam, are generally used in the japanning ovens. Dry heat, usually from a gas-fired oven, is more intense in its effect than steam heat by at least 20 to 30 deg. F., or, in other words, a varnish baked at 140 deg. F. for two hours by dry heat will have approximately the same hardness as one baked at 160 deg. F. by steam heat for the same length of time.

Furthermore, less discoloration takes place under the influence of steam than with dry heat, due to the condition of the hot air in the oven.

All japanning ovens should be provided with dampers and escape flues for getting rid of the fumes, smoke, etc., otherwise the drying will be greatly retarded.

The work intended to be japanned or baked, no matter whether it is brushed, dipped, or sprayed, should be allowed to stand until the paint or varnish has "set" before it is put in the oven, and it should never be placed in the oven when the temperature is at its maximum, as the work will show streaks, spots and variations in lustre, and more "fullness" at the bottom than at the top of the article.

It is best to start with a minimum or low heat and gradually raise the temperature until the desired point is reached, then hold it there for the given length of time.

The various temperatures connected with the baking of paints, enamels, varnish, etc., will be governed by the composition of the article to be baked, for instance, wood or metal; the color and kind of paint and varnish; the number of coats; and the length of time the work is to be baked.

Woodwork, as a rule, no matter what kind of paint, enamel, or varnish used, cannot be baked at a higher temperature than that required to drive off the moisture or water in the wood.

With one-coat work on ordinary work the baking heat should not exceed 200 deg. F., and even this will be too high if the baking is prolonged.

To insure satisfactory results and permit of as high a bake as possible, the wood should receive a priming coat of "thin oil," made by thinning three parts of boiled linseed oil with one part of benzine.

This priming coat is to be baked at 220 or 240 deg. F. for two hours, then allowed to cool. It will be found that the oil has blistered in spots, due to the escape of moisture, therefore smooth the surface with sandpaper, give the article another coat of "thin oil" and bake at 200 deg. F. for three hours, then allow to cool until the next day. By this procedure the first coat will have had a five-hours' baking at an average temperature of about 210 deg. F. and be perfectly dry, while the second coat will be soft enough to take the subsequent coats of paint.

If the article is to be finished in white or any other delicate pale color, thin the paste paint to brush consistency with a mixture consisting of five parts of pale baking varnish, two parts of turpentine and one part of kerosene.

Bake this primer at 180 deg. F. for two hours. This heat will cause the priming coat to turn slightly yellow, but it is essential that the primer be decidedly hard. The second coat may consist of a paste paint thinned as above, or the proportion of thinners may be varied to secure any desired result. Turpentine exerts a flattening effect and is driven off quickly by heat, consequently its only function is to thin the paint and reduce the lustre.

Kerosene is driven off very slowly by the baking heat and, unlike turpentine, does not exert a flattening effect. It acts as a thinner, improves the flowing and levelling properties, and imparts toughness, also permits of a higher baking heat without showing discoloration. It, however, retards the drying and gives rise to numerous bubbles when the paint is applied with a brush.

The second coat of paint should either be baked at a lower heat for the same length of time as the primer, or at the same temperature for a shorter time; usually it is baked at 160 deg. F. for two hours.

The final varnish coat, in compliance with the above treatments, should be baked at 140 or 150 deg. F. for about two hours.

As a rule, each succeeding coat is baked at a lower temperature, usually 20 degrees, than the preceding one.

Wooden articles are most difficult to bake, as the wood is warped by the heat and the moisture in escaping causes the paint to blister.

Very little difficulty is experienced with iron, brass, tinware and other metals in baking, providing certain precautions are taken.

For instance, iron work must be free from grease, oil and dirt before applying a coat of paint or baking varnish, and it is best to slightly roughen the surface with fine sandpaper or by means of a sandblast.

Brass castings should have the sand and scale removed by pickling before applying the baking material.

Tinware must not be subjected to a higher heat than 350 deg. F., otherwise the solder will melt.

Planished zinc and copper should receive a wash of copper acetate solution, made by dissolving one pound of neutral acetate of copper in two gallons of warm water. Allow to dry on the surface, wipe off the dry powdery oxide with a dry cloth, then apply the paint or varnish.

Aluminum is the most difficult of all metals to paint, or rather, to make the paint adhere to it.

The nearest approach to success consists in first going over the surface with a strong solution of caustic potash, made by dissolving two pounds of concentrated lye in one gallon of hot water, then rinsing with clean hot water, allowing to dry, and finally applying a coat of the neutral copper acetate solution.

With the surface of any of these metals in proper shape

they are then ready for painting and may be finished flat or glossy, in any desired color.

Priming Coats

The primer or undercoat should be non-absorbent, but must possess sufficient "tooth" to take the second coat.

Lithopone, zinc oxide, whiting, asbestine, barytes and silica are the pigments generally used for the primer.

White lead may be used if the work is to be baked by steam, but in a gas-fired oven the lead is liable to be discolored by the sulphuretted hydrogen.

The proper baking temperature for a white primer is 180 to 220 deg. F, but a trial must be made first to see if it will stand the higher heat without discoloring.

A trial test for time must also be made; for instance, the white primer must stand a bake of two hours at 180 deg. F. and only one hour at 220 deg. F. without discoloring.

In such case, the choice of heats will depend upon the subsequent coats and the number of bakings.

If the work is to receive a second coat of flat white and a finishing coat of pale varnish, then the lower temperature with a two-hour bake should be used.

Now, if the second coat of flat white is baked at 160 deg. F. for two hours, and the final coat of varnish at 140 deg. F. for two hours, then the primer will have been subjected to a baking time of six hours in all, at an average temperature of 160 deg. F.; the second coat has been subjected to four hours' heat treatment of 150 deg. F.; and, finally, the varnish has been subjected to a two-hours' bake at 140 deg. F.

Similar results could have been obtained by baking all of the different coats at 150 deg. F. for different lengths of time, namely—the primer for six hours, the second coat for four hours, and the varnish for two hours.

There are a great many different ways of baking; that is, in regard to temperature and time.

Some japanners prefer a long bake at a low temperature, while others claim that better results are obtained by baking for a short time at a high heat.

Hardened damar varnish may be baked at 220 deg. F. for two hours, or at 300 deg. F. for half an hour without being discolored, but none of the oil varnish will stand baking at 300 deg. F. without turning yellow or brown.

As a rule, a good baking varnish will stand the following heats, viz., one hour to 160 deg. F., or two hours at 150 deg. F., or three hours at 140 deg. F.

Some of the hard gum varnishes, such as Congo, Kauri, and North Coast, will stand baking at 180 deg. F., but the rosin varnishes will not stand this heat, due to the fact that rosin itself begins to soften at a temperature of 154 deg. F. However, by treating the rosin with glycerine of calcium, it may be made to stand a much higher temperature without softening.

The amount of oil in a baking varnish has much to do with its baking properties; if too long in oil the varnish will wrinkle, "craze," and lose part of its lustre in the baking; if too short in oil the film will be hard and brittle.

Experience has shown that the best results have been obtained with baking varnishes containing from 16 to 32 gallons of oil per 100 pounds of gum.

Polishing and rubbing varnishes with 4 to 12 gallons of oil may be baked, but becomes harder and more brittle than when allowed to air dry.

Black baking japans with Gilsonite, asphaltum, or man-

jack for a gum base, usually contain from 4 to 24 gallons of oil, and in some cases 32 gallons.

These blacks when made for high baking heats, 300 to 5,000 deg. F., invariably contain a large amount of kerosene oil as a thinner. Kerosene oil is essential in black baking japans, in baking paints, and in baking varnish.

It promotes flow, is not volatilized by heat as rapidly as turpentine and benzine, and adds greatly to the toughness of the material.

Canadian Shortage of Paint Materials

It is reported that paint manufacturers in Canada are meeting with difficulties in securing materials for their product. There is a demand in other lines for the pig lead obtained formerly in British Columbia, while the supply of zinc from Belgium and France is now cut off, but is being obtained to some extent in the United States. Canadian manufacturers are also deprived of coloring materials like the siennas from Italy and color-making chemicals from Germany.

A few months ago a retail merchant forwarded to the Dominion government for analysis a brand of paint offered direct to consumers at 33 cents per quart. The merchant was advised that the pigment had very little covering power, consisting mostly of barium sulphate and silicates, while the vehicle or liquid portion of the paint was stated to contain no linseed oil.

Mixed paints are retailed by the imperial gallon. The paint referred to above was therefore offered at \$1.32 per imperial gallon, while the price of the better quality of mixed paints even before the war was \$2.25, later increasing to \$2.50, and since April 1. the local price has been \$2.75. There is no paint made in New Brunswick, most of it being imported from Ontario, though some purchases are made in Halifax, Nova Scotia.

Survey of Ford Profit Sharing

Henry Ford announced the plan whereby his employes should share in the profits of the company early in January, 1914, and put the plan into effect on the 14th of that month of a minimum wage of \$5 for every employe. Statistics gathered in two surveys, one in 1914 after the plan had been in operation for five months, and the other which has just been completed, show:

The average bank deposit of the 29,314 men now employed, is \$204, as against \$62.12, the average of the 12,960 men employed in 1914.

The bank accounts of the present employes total \$5,968,936, an increase of nearly \$5,000,000 over two years ago.

The number of bank depositors has increased from 5,872 to 17,116.

The men are now buying homes worth \$21,787,493, an increase of \$18,500,000.

In 1914, 2,572 carried life insurance totalling \$2,471,663; in 1916, 17,116 men are carrying \$14,822,916, an increase of over \$500,000 a month.

Two year ago only 364 of the men owned their homes; today 1,136 are home owners.

The total wealth of employes, as represented by bank accounts, real estate and real estate equities, is \$8,096,460, an average of \$617.33 for each man.

Nearly 12,000 more men are now renting homes than in 1914, which has caused the number of men paying board bills to decrease 50 per cent.

Large Single vs. Dual Solid Tires for Rear Truck Wheels

By W. A. Allen*

Abstract

This paper is mainly an argument in favor of the use of large, single rear wheel truck tires instead of smaller dual tires. Although the practice of using large singles is comparatively new, the author gives the results of experience and research to show the advantages of the newer method of rear tire equipment.

In developing his arguments in favor of single tires, the author goes into the history of dual tire application to show why it was necessary to use two tires in the earlier days of truck operation. As the necessity for increased carrying capacity grew, tire manufacturers found the then existing single tire equipment inadequate, and they set about to develop suitable equipment to meet the new condition, the result being dual practice. According to Mr. Allen, dual tires were supposed to have a carrying capacity $2\frac{1}{2}$ to 3 times that of a single tire of the size of which the combination was composed. The method of attaching the earlier dual tires is shown to have been poor, inasmuch as the cross bars tended to draw the rubber together in such a way that it was impossible to secure the same degree of friction over the entire base, owing to the outward spring which took place in the center of the crossbar, thus relieving compression under these bars. This reduced the stability of attachment, which resulted in circumferential creeping of the whole tire to a much greater extent as the width of the dual equipment increased. Inability to correct this weakness resulted in conclusion to the effect that tires of such method of attachment were not suitable when widths in excess of 4 or 5 in. were employed. The metal base type of tire was developed to overcome the difficulty.

Mr. Allen holds that dual tires are overrated, and believes that the practice of saying that dual equipment is capable of carrying loads double that of the single of which it is composed, is open for discussion.

Some reasons for advocating large singles in place of small dual equipment are:

1. The contact area of single tires exceeds that of the duals which they are proposed to replace.

2. The load per sq. in. distributed over the contact area is in every case reduced correspondingly with the increase in contact area.

3. Small dual equipment does not give satisfactory performance for the reason that neither single tire is sturdy enough to resist momentary imposition of the total wheel load, such as occurs, for example, when traveling over rough road surfaces, excessively crowned or furrowed roads. It is pointed out that in such cases one of the small tires carries during a large part of the time the entire wheel load, which is shifted back and forth from one small tire to the other; with large, single units the load is concentrated on a tire sufficiently sturdy to absorb reasonable load inequalities.

4. Saving in tire cost, ranging from 8 to 15 per cent.

5. Saving in wheel cost, because of narrower felloe and wheel rim.

6. Saving in cost of handling and applying one tire in place of two.

7. Saving in wheel, tire and rim weight.
8. Fitting of non-skid chains easier.
9. Better trackage with front wheels.
10. Greater height of rubber tread, providing better cushioning properties and increasing tire life.
11. Less strain on axle and wheel bearings.

The large single tire has, however, its limitations and pending the results of further investigation, it seems advisable to consider 7 in. tires as the limit of practical single equipment.

Research and practice, covering a somewhat extended period, have brought to the author the conviction that the use of large single tires, rather than a pair of small units on rear truck wheels, while still comparatively new, has nevertheless proved a progressive development. In order to discuss the subject thoroughly a brief historical review of the solid tire industry will be enlightening.

The use of dual or twin truck tire equipment was inaugurated during the early development of an infant industry. It was offered as the then most practicable way of meeting conditions, the exact severity of which were not thoroughly known. An accurate forecast of the vari-

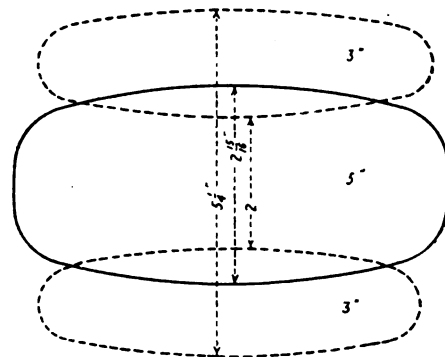

Fig. 1—Relative bearing contact (2,500 lbs. load) for 3 in. dual and 5 in. single tires

able operating conditions that followed the extension of the industry into all phases of commercial transportation was not then possible. Due to such extension, the service has become more severe along lines of greater loads, higher speed and increased zone of activity to the point of overbalancing such bettered conditions as improved roadways, more skillful operators and improved suspension and design.

Original Reasons for Dual Tires

Early in the development of a solid tire that would satisfactorily meet the demands of commercial truck service, three requisites were encountered. Listed in order of importance, these are: (1) Large carrying capacity; (2) permanency of attachment; and (3) freedom from tendency to skid.

The necessity for increased carrying capacity soon appeared, and shortly tire manufacturers found no existing single tire equipment adequate to meet practicably and serviceably the new conditions. They at once started to develop suitable tire equipment, the result being that dual tires were recommended for all necessities above the range of single tire equipment. Later the practice was extended to rear wheels generally, because tires applied in dual form were in some manner calculated to equal in carrying capacity from $2\frac{1}{2}$ to 3 times that of one of the units of which they were composed. Just why this was so con-

*Manager of truck tire department, B. F. Goodrich Co.
Paper presented at semi-annual meeting, June 12-16, 1916, of Society of Automobile Engineers.

sidered has never been satisfactorily explained. It must therefore be assumed that the original capacities, which are in effect today with no material change, were reasonably accurate. Practice and observation have confirmed the fairly general reliability of these schedules. Intelligible service or performance data are scarce, however, and so we find existing capacity schedules considerably deviated from in a number of instances. All these practices should be harmonized and a new and correct schedule should be established and followed.

Early Methods of Attachment

Permanency or stability of attachment will now be considered, with reference particularly to its influence on dual

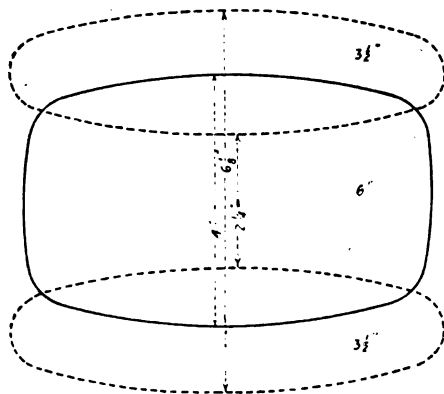

Fig. 2—Relative bearing contact (3,500 lbs. load) for 3½ in. dual and 6 in. single tires

tires. The early type of tire was attached by circumferential wires or other clamping means to provide substantially a compression of the rubber tire, in turn bringing its base into direct and firm contact with the wheel rim. The friction between the wheel rim and tire base thus obtained was designed to exceed the driving torque. Most prominent of these types was that in which solid metal cross wires were embedded in the tire base at frequent intervals and extended laterally across the tire in such a manner that the ends were exposed. Circumferential wires were fitted over these ends under sufficient tension to draw the cross wires radially inward, thereby compressing the rubber underneath so as to secure and maintain a frictional contact between the tire and rim.

Then, as at present, the application was one depending upon frictional fit to perform properly its intended function. As this type of tire was increased in width it was found impossible to secure the same degree of friction over its entire base, owing to the upward spring that took place in the center of the longer cross bars, thus relieving the compression of the rubber under these bars. As a consequence the stability of attachment was reduced, resulting in circumferential creeping of the whole tire to a much greater extent than was true of those of narrower design. This movement resulted in rapid damage to the base and the tire was rendered useless prematurely, while its tread showed almost no wear in many cases. Inability to correct this weakness resulted in the conclusion that the design was not suitable for tires of greater than 4 or 5 in. width.

It was at this point that dual tires made their entry. Even triple applications were made in some cases. While results were somewhat more satisfactory, much room was still left for improvement. No similarly fastened tire has ever been free from the weaknesses explained, particularly

when used as equipment for driving wheels and when subject to varying and indifferent methods of application.

The third condition, namely that of tendency to skid, may be passed over with little discussion since this was wrongly considered as being wholly attributable to the design or character of tire. It is now generally recognized as being directly traceable to conditions of driving and braking.

New Type of Attachment

Early in 1909 a new tire designed to correct the weaknesses of previous types was placed on the market. In general this type resembled similar tires used to some extent in continental Europe, although they were not advanced beyond the experimental stage. The American tire, commonly referred to as the "metal base" type, embodied some entirely new features of shape and construction, and stands today, with minor refinements, as representative of the most advanced and successful practice. With the development of this tire, together with efficient standardization and accuracy in wheels, we have a condition whereby correct application is practically assured in every case. The frictional fit is adequate under the most severe conditions to resist any tendency for movement of the tire in any direction, regardless of size, since adhesion of the metal base to the felloe band increases directly with the tire width. This fact accounts largely for the perfection of attachment of the rubber tread to a steel rim or metal tire base, unattainable in any other known manner. The result is uniform and successful performance, as is amply evidenced by the results obtained. Weaknesses inherent in single tires of large size were overcome in this later type, so that such tires were at once brought into the field of practicability.

Dual Tires Overrated

The practice of rating two tires when applied dually at from 25 to 50 per cent bearing more than the sum of capacities

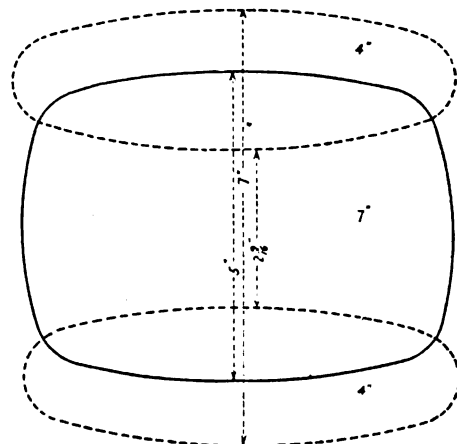

Fig. 3—Relative bearing contact (5,000 lbs. load) for 4 in. dual and 7 in. single tires

of the singles that make up the dual unit, is believed open to discussion, if not to direct criticism. No rule of theory or practice exists that will show such possibilities. It seems manifest, however, that dual tires are somewhat overrated, while singles may be somewhat underrated, according to existing schedules. This subject is under careful investigation. It is believed that a more logical schedule will be proposed in the near future. Such a schedule should in no case rate duals at more than the sum of the capacities of the single units employed. This

would correspond to foreign methods, as well as be more nearly mechanically correct.

Single Tires to Replace Duals

Since it is proposed that single tires of certain sizes replace dual tires of stated sizes, a comparison of carrying capacity according to existing capacity schedules for the given sizes will follow. This comparison will indicate that the proposed single tires are not equal in capacity to the dual tires they are expected to replace. In order to explain this point Table I and Figs. 1, 2 and 3 have been prepared. In each case the data are the composite results of several experiments made under ideal and similar conditions. Table I shows clearly that in every case with equal loading the contact area of single tires exceeds that of the dual tires they are expected to replace, and that the load per sq. in. distributed over the contact area arrived at is in every case reduced correspondingly with the increase in contact area. Obviously, this is in favor of the single equipment. Figs. 1, 2 and 3 show the area of contact, the shape of the area and the reduced width of tread. This reduction in width of tread ranges from 30 to 40 per cent and is of material importance.

Table I. Carrying Capacities of Single and Dual Tires. Distributed

Size of Tire, In.	Type.	Load* Applied, Lbs.	Contact Area, Sq. In.	Load, Lbs. per Sq. In.
36 x 3	Dual	2,500	16.5	151.5
36 x 5	Single	2,500	17.2	145.4
36 x 3½	Dual	3,500	23.6	148.3
36 x 6	Single	3,500	24.0	145.8
36 x 4	Dual	5,000	26.9	185.8
36 x 7	Single	5,000	31.5	158.7

*Corresponds to present schedule ratings for dual tires in sizes being compared.

Effects of Overload

All materials have a well defined limit of capacity for distortion in varying directions. Rubber is no exception, but its capacities are truly remarkable; in a popular sense its most natural enemy in solid-tire service can be considered as overloading.

Self-Lubricating Bearings

A radical departure in bushing construction is seen in the O. and S. Never-Oil self-lubricating bearings and bushings, made by the O. and S. Bearing Co., Detroit, Mich. Primarily these bearings are for use in places where oscillating or slow moving parts are to be taken care of, such as spring eyes, tie rods, torque arms, brakes, steering gears, etc. The bearing consists of a compressed mineral fibrous lubricant that is confined between two steel shells, rendering under all conditions of service a perfectly lubricated dust proof bearing that is free from climatic influences.

These bearings have been adopted as standard part of the construction of some of the largest automobile and parts manufacturers in the country.

The double member bearing for use in spring eyes or heavy duty oscillation is assembled by press fit in the spring eye or retainer. The bolt is slotted to match the stamped keys on the inside of the bushing, which prevents slipping of the bolt. The shackles are drawn tight against the extension of the inner member, thus preventing end squeak and assuring perfect oscillation of the entire bear-

ing surface on the pre-lubricated fibrous material between the outer and inner members.

Tests have proven that almost without exception the bearing outwears the spring or part to which it is applied.

The single member Never-Oil bearing or self-lubricating bushing is a steel shell lined with the pre-lubricated fibrous material. This bushing can replace any of the present metallic bushings, and is used in tie rods, brakes, steering gears and other oscillating or slow revolution parts of automobile construction in any dimension having not less than 3/32 in. wall. A test case was made recently by a large manufacturing concern, which reported that after subjecting the bearing to 3,500,000 oscillations, giving 165 half-turns per minute, with a carrying load of 900 lbs., the result showed no noticeable wear at all.

For Preparedness in St. Louis

The unpreparedness of the United States for war was the subject of discussion taken by several speakers at the May meeting of the members of the St. Louis Hardware, Vehicle and Implement Manufacturers' Association, held at the Planters' Hotel.

W. H. Roninger, manager of the Banner Buggy Co. among others, declared the United States should spend millions of dollars in building the most powerful navy in the world to protect itself from attacks which foreign nations, impoverished by the present war, will be tempted to make on account of our temptingly large amount of wealth, at the close of hostilities. At the close of the meeting a preparedness resolution was drawn and adopted, to be sent to Washington.

Uphold Buggy Rate

The Interstate Commerce Commission last month handed down a decision on a complaint filed by the Marshalltown, Ia., Buggy Co. against the Burlington Railroad, in which it holds that a rate of 91.5 cents per 100 pounds on buggy bodies, less than carloads, crated, from St. Louis to Marshalltown, was not unreasonable.

The complainant's principal evidence against the rate was the fact that a commodity rate on buggies, knocked down and boxed or crated, with wheels, seats and tops inside, was applicable at the time of movement. The Commission upholds the contention of the carrier that buggy bodies are more fragile than complete buggies fully boxed or crated.

Caffrey Business Sold for \$10

All the right, title and interest in the good will in the business carried on by Charles S. Caffrey in Camden, N. J., in his lifetime and in the name of Charles S. Caffrey as a trade mark, was sold recently at the Camden Court House by Mahlon W. Newton, the executor of the estate. It was purchased by the Excelsior Drum Co. for \$10. The Excelsior Drum Co. are the present occupants of the building at Tenth and Market streets, where the late Charles S. Caffrey carried on the business in the building of light carriages.

Don't sell side lines too close with the idea that they do not need to carry their share of the running expenses. A side line is as much part of the business as any portion of the main line.

N. A. C. C. Elects Officers

At a record gathering of automobile manufacturers in connection with the annual meeting of the National Automobile Chamber of Commerce, Inc., in New York, June 7 and 8, Charles Clifton, of the Pierce-Arrow Motor Car Co., was again elected president of the organization. The other officers elected are as follows:

Vice-president, Wilfred C. Leland (Cadillac); second vice-president, Hugh Chalmers (Chalmers), gasoline division; second vice-president, Windsor T. White (White), commercial vehicle division; second vice-president, H. H. Rice (Waverley), electric vehicle division; secretary, R. D. Chapin (Hudson); treasurer, George Pope; general manager, Alfred Reeves.

The commercial vehicle makers in the N. A. C. C. held a commercial vehicle convention at which many standards were adopted, furthering the plans for more efficient service to the buyers of trucks as well as of pleasure cars.

The commercial vehicle convention decided that no truck show was necessary at this time, although the pleasure car shows will be held in both New York and Chicago. They decided against any change in the standardization of frame widths at this time.

For the protection of buyers of trucks, a standard definition of motor truck chassis, both gasoline and electric, was decided upon and the convention, together with the annual meeting, approved a form of service policy which is expected to supply even better service to the car owner.

Almost all the 97 companies holding membership in the N. A. C. C. were represented at the meeting.

St. Louis Accessories Elect Officers

At the regular monthly meeting of the Motor Trade Accessory Association, held May 16, at the Marquette Hotel, St. Louis, the following officers were elected for the coming year: L. E. Allmon, manager of the Missouri Auto Specialty Co., president; Everett S. Marvin, Imperial Oil Co., vice-president; A. R. Baxter, Phoenix Auto Supply Co., treasurer; directors, F. M. Moore, manager St. Louis branch of the Firestone Tire and Rubber Co.; Leonard N. Coats, Commercial Auto Body Co.; William L. Ferrier, Fred Campbell Auto Supply Co.; Louis Moller, Jr., Rapp & Moller Carriage Co.; Allan H. Clark, Vehicle Top and Supply Co.; sergeant-at-arms, George Schatgen, Fisk Rubber Co.

Allan H. Clark, retiring president, presided at the meeting and introduced the speakers. The chairman of the legislative committee, E. S. Marvin, read the report regarding what automobile row had done to help the recent clean-up week campaign. The moving pictures taken by Albert von Hoffman of the Automobile Baseball League teams in action, was very much enjoyed by the members.

St. Louis Builders Meet

The St. Louis Carriage, Wagon and Auto Body Builders' Association held its monthly meeting at the American Annex Hotel, May 23, with 65 members present. Louis Moller, Jr., president of the association, presided.

At the April meeting the association addressed a resolution to the Congressmen representing the St. Louis districts, asking for relief from the shortage of materials necessary for the carriage and automobile trades. Replies were read from Speaker Champ Clark, Secretary of the Interior William Redfield, Senator James Reed, and Rep-

resentatives Igoe and Dyer. All shifted or disclaimed any responsibility, but promised that an effort would be made to remedy the situation.

A motion was made and carried to have a picnic at Normandy Grove, and the entertainment committee, with Frank Kranz as chairman, was instructed to complete arrangements. A cabaret and musical entertainment was provided. There will be no more social meetings of the association until September.

Parts Makers in Big Merger

A merger capitalized at \$10,000,000 has been formed by the Rands Mfg. Co., Vanguard Mfg. Co., Superior Mfg. Co., Universal Metal Co., and the Diamond Mfg. Co., to be known as the Motor Products Corporation. The new company will have its main office in New York City and its headquarters office in Detroit. W. C. Rands, president of the Rands Mfg. Co., is president; D. B. Lee, vice-president of the Diamond Mfg. Co., treasurer and general manager; C. F. Jensen, president of the Vanguard Mfg. Co., vice-president and director of purchases; H. H. Seeley, president of the Superior Mfg. Co., vice-president and sales manager; M. Louis Brown, treasurer of the Universal Metal Co., secretary, and also manager of the tube mill, and R. R. Seeley, production manager. It is purposed to build a large plant to take the place of the four Detroit ones, erect a new factory in Walkerville, and enlarge its factory in Ann Arbor.

It might appear at first thought that windshields will be the main product of the corporation, but W. C. Rands says that the company has many other fields of manufacturing in view and that, among other plans of the organization was the installation of a drop forge plant and the addition of a large screw machine department to the activities of the organization.

Eventually the windshield business of the corporation will not be over 30 per cent of the total business, said Mr. Rands.

Comet Automobile Co. Formed With \$1,000,000 Capital

The Comet Automobile Co. has been incorporated with a capital stock of \$1,000,000, to manufacture automobiles and commercial trucks, at Rockford, Ill. The auto, which will be known as the Comet, will have six cylinders and a wheelbase of 112 in., and will sell at about \$800. The trucks will sell at about \$1,000.

The company has rented offices in the Rockford Trust Building, where several floors will be utilized for workout and testing purposes. Later, factory space will be secured with 50,000 sq. ft. of floor space. It is planned to put 100 men at work, increasing this number as business warrants. Following the acquirement of a temporary location, the company will construct a building with at least 300,000 sq. ft. of floor space.

The officers of the new company are the following: President, Harry R. Sackett, Chicago; vice-president, Joseph Callahan, Chicago; treasurer and general manager, George W. Jagers. The secretary, who is at present engaged with another firm, will be named later. It is planned to place the first car upon the market September 1.

Mr. Jagers will be in active charge of construction. He is a practical engine man, also a body builder and will eventually build the bodies and motors in the Comet factory.

To What Extent Shall Car Builders Make Parts

In answer to the questions: Should a car manufacturer make his parts, or should he assemble them, and if he should manufacture them, what proportion should he make and which should he buy? H. M. Jewett, president of the Paige-Detroit Motor Car Co., told those attending the regular monthly meeting of the Detroit Section of the Society of Automobile Engineers the evening of May 18 that it is all a case of the individual conditions with each company. From the experiences and troubles each maker has had, he has his own ideas of what he should and should not buy from the parts makers. One large producer may make some part that another concern equally big has always purchased from a parts manufacturer, and there are so many qualifying conditions that no rules can be laid down.

Each manufacturer can take his particular viewpoint on the subject of manufacture versus assembly from his own personal experience in the business. Mr. Jewett divided the subject into four parts: the manufacturer producing a high priced car costing \$3,000 or over, in limited quantities; the volume producer making 10,000 machines or more; the maker that is forced into the manufacture of certain parts through business necessity; and the parts that are seldom manufactured by the automobile company.

Taking up the first of these, naturally the high priced cars are produced in limited quantities, and the result is that in order to get high price, the machine must have extreme individuality. The maker of that car must really make practically everything there is in it, for the purchaser of a high priced car has to feel that he is getting the worth of his money. The automobile maker in that class can ill afford, according to Mr. Jewett, to buy axles, engines, bodies, frames, wheels, etc., from parts manufacturers, because the latter are producing parts for cars in volume business, and it would be very difficult, from a sales standpoint, to convince the car buyer that such parts are any better than the ones made for the volume producer. This is especially true because the volume producer is advertising that on account of his quantity he can buy cheaper, so naturally, with his limited output, the high priced maker would have that argument to face.

Going to the second division—the volume producer—there is great opportunity for diversity of opinion here. It is a common supposition that a manufacturer producing over 10,000 units can make his parts cheaper, said Mr. Jewett, but he questioned if that is entirely true, mentioning some conflicting policies of big makers to show that all do not hold any unified view of the matter. He showed where Overland, for instance, buys certain parts; he cited some of the Buick company's units that are made outside its plants; he called attention to Studebaker's purchasing certain things; mentioned other plants in a very frank manner, and gave it as his opinion that conditions altered cases and that there were good reasons back of each policy.

Many of the accessory makers themselves are not making every part. They assemble too, Mr. Jewett explained. A great many of the axle companies today are buying the gears that go into their units; gearset makers do the same thing, buying gears and malleables and machining and assembling them.

But there are certain things that manufacturers very seldom make. Bearings are one. Usually these are patented processes, requiring intricate and costly machinery, and a car maker can go out and purchase a bearing from a firm making a specialty of this part and secure a better bearing and cheaper than it could be made by the car plant. This example holds good for a great many of the parts that are seldom made by the car factory. Steering gears are another thing seldom made by the car factory; frames might come under this class also.

The machinery often required for the making of certain parts would not be economical for a great many manufacturers of cars to install. Take, for instance, rear axle housings. A press to do this would be capable of such large production that unless the maker were a very large producer the press would lie idle practically three-quarters of the year, which is not economy.

Manufacturers have two ways of looking at the condition. One spends a great deal of money telling the public that he is an assembler; another that he makes everything in his cars.

As an illustration of peculiar conditions that are to be found in each individual plant, Mr. Jewett told of walking through a purely assembly plant one day and noticing that they were enameling fenders. He asked why this was done, since no other part of the car was manufactured. The reply of the superintendent was that they could not get the fenders enameled well enough outside. This suggests the thought as to why others are not enameling them for the same reason. Very possibly those others that are not enameling them are having very good success with fenders they buy already enameled. That is the only answer, because if all were having trouble in getting deliveries on properly enameled fenders, they would all have enameling plants the same as this particular case.

This leads to a consideration of the manufacturer who is forced to make his parts. Wherever a maker makes his own parts there is a substantial reason why he spends his money in machinery, tools, equipment and material instead of buying the unit. According to Mr. Jewett, you will find generally that each part that a manufacturer produces himself results from not being able to get deliveries or a fair price from the parts maker or through not being able to get this part good enough. He may not wish to buy a standard motor because that engine may be used by several different makers of cars selling at various prices.

The amount of capital needed to make cars outright is another consideration. Where the maker buys from a parts producer the latter's capital is being used in the business, and just as long as the car maker can buy those parts as good as he thinks they ought to be and at a right price, Mr. Jewett does not think any car maker is going to get into the parts making business. However, the motor is the most logical thing to produce, it being the most important part of the car.

The Paige president paid tribute to the brains of the S. A. E. that have made possible the interchange of parts of standard design through standardization.

The Discussion

Mr. White, in opening the discussion, commented that in one particular price class the reason why manufacturers make a great many of their parts is because of class individuality. Another is the refinement of workmanship. Special conditions of silence, durability and workmanship

dictate the individual manufacture of special parts. Then there is the matter of quality of material, which the individual maker can insure if he makes his own parts. In another class, in quantity production, where they have to buy parts, they have trouble due to lack of material. Sometimes there is practically only one part maker making a particular thing, and these concerns may be so full of orders that they are incapable of producing parts having special refinements. There is also the matter of prices which certain parts makers charge. In making special things, parts concerns are often confronted with the lack of floor space, and sometimes for financial reasons they simply cannot afford to lay down the special equipment necessary.

Taking up the discussion, Mr. Zimmerschied said:

I have been very much interested in Mr. Jewett's exposition of this subject, and I know that the engineers can profit greatly by it, because he has given us a business view of it; and if there is anything that most of us engineers need, it is a little glimpse of the business side once in a while. At the same time we like to draw pictures and look at diagrams and curves, and perhaps I can organize the thoughts I have in my mind if I draw such a chart.

To my mind, the automobile industry can be subdivided in two ways a sort of dual classification. First, quan-

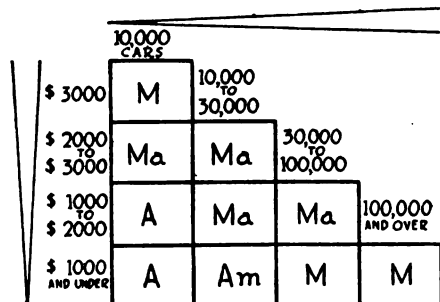

Chart drawn by K. M. Zimmerschied

tity, and second, price; something like the illustration. Quantities up to 10,000 cars, in the first class. From 10,000 to 30,000 is what you might call the medium quantity production. Thirty thousand to 100,000 plus is the super-quantity production class, you might call it. Then down the other way we will start with \$3,000 and up, \$2,000 to \$3,000, \$1,000 to \$2,000, and under \$1,000. Now, we find, if we go to cross-section all this area, that we would not be able to fill in all these spaces, because the \$3,000 class never rises above 10,000 a year; so we have a square for that class that never will get higher in production. However, the \$2,000 to \$3,000 class will run over here into the 10,000 to 30,000 per year. The \$1,000 to \$2,000 might run over into the 30,000 to 100,000, and in the \$1,000 down we run out into the 100,000 plus. So that that covers practically the field of all our automobile endeavor.

Now, if we plot the tendency toward the manufacture of his own parts, we would find, as Mr. Jewett has said, that in the \$3,000 class, that is the maximum, because the manufacturer wants the extreme of individuality; so we will draw here a wedge, running to practically zero at the bottom, the thickness of that wedge at any point indicating the tendency toward manufacturing his own parts which the manufacturer in that class follows. And in the same way we find another wedge, running out this way, which would indicate the pull on the manufacturer to make his own parts, on account of quantity.

Now, in any one of these squares, it is evident that the summation of these two tendencies, and these two bases, would be in the \$3,000 class, to manufacture all the parts. We will see here, more than in this case of maximum production, a maximum cheapness to manufacture all the parts. We might find very largely the same tendency here, and a similar tendency toward assembly; so I will introduce two small a's. Maximum tendency to manufacture, but on account of this component, a small tendency toward assembly. Why? On account of these two, it is all assembly, small quantity, small price. They have not the capital, they have not the draw to manufacture the parts.

Now, then, suppose a group of men are going to start manufacturing an automobile. They think it is a good field to go into, and they are going to market the product. Following the line of least resistance, they would start in some of these classes here to manufacture a conventional product, which has a steady market, buying most of their parts outside. In trying to sell that product, however, they find at the end of the second or third year that they are not getting along very fast, because they have not this individuality which sells. They have got a lot of parts, a lot of manufacturers, and they are very much like their neighbors' cars; so in order to gain an influential position in the industry, they have either the choice of going up in price and getting into the individualistic class there, or else going out the other way and getting a large volume, and larger profits, without necessarily sacrificing individuality. But you notice it is always a question of individuality, if you are going to establish, to attain a position in the business, an influential position.

Now, on the position of the parts manufacturer, I think that we owe a great tribute to the parts manufacturers for a great many of our big advances. The old saying that "necessity is the mother of invention" is not so true, to my mind, as that "competition is the mother of invention."

"Now for a Buggy Ride"

The third and last poster issued by the Vehicle Trade Press Committee, entitled "Now for a Buggy Ride," has been issued. It is 15 x 29 inches, printed in four colors, and, like its predecessors, exemplifies the delights and comforts of a buggy ride. Dad is seated in an up-to-date runabout, while sonny approaches with outstretched arms exclaiming, "I'm coming, daddy."

These posters can be secured at low cost by manufacturers and dealers, as the C. B. N. A. is bearing the expense of the original painting, and plates.

A sample, with the special low prices quoted, will be sent to manufacturers and dealers who make the request on their business stationery, addressed to the Vehicle Trade Press Committee, A. M. Ware, chairman, 1010 Arch street, Philadelphia.

Newly enacted legislation in New York compels the owner, when offering for use a stallion, to register full description, breeding, etc., of the animal, accompanying same with a certificate for soundness from a veterinarian. Any incurable or infectious disease with which the stallion may be afflicted disqualifies him for public use. Three dollars is the fee for such enrollment, \$1 for renewal and 50 cents for transfer of the animal.

Live Auto Show

Something new in automobile shows was inaugurated Saturday, May 20, at the Panama California International Exposition, when the motor demonstration field was opened with a big program of special automobile events. Down at San Diego the automobile is not permitted to sit idly on a Persian rug and attract attention by its beauty.

At the conclusion of the opening day program, dozens of cars were dust covered and some of them battered, but the big crowd had enjoyed a truly Roman holiday and the automobile dealers had established the merits of their cars, to say nothing of the resourcefulness of the drivers. The exposition has built two grades 35 and 50 per cent for the purpose of demonstrating hill-climbing ability.

The Metz car and the Saxon were not quite able to climb the smaller grade on the high, although many attempts were made. However, it was not the fault of power so much as traction, as the hill was badly cut up and the grade was covered with light sand. The slow race in high was won by a Paige; the quick get away race was won by a Hudson supersix, and the Australian pursuit went to Talcot P. Smith of the Saxon agency.

The Australian pursuit race is not a test on the car, but is a trying one for the driver. One lap of the track is made in the car, the second lap is made on horse back, the third lap is made on a bicycle and the final lap in the car. In addition to these contests, tire changing competitions were held and many other features of interest to motorists were offered, following the big automobile parade from down town.

The automobile reserve corps of California made a test run to the motor demonstration field and gave their maneuvers showing the superiority of motor trucks to cavalry, both on the march and in actual field tactics. United States regulars from Fort Rosecrans participated in the maneuvers.

Special programs will be given on the motor demonstration field each week and exposition bronze buttons will be given to all motorists traveling more than 500 miles coming to the exposition, and a Tiffany silver medal, given by Motor, will be presented to all trans-continental motorists.

Kentucky Wagon Gets Army Contract

The Kentucky Wagon Works, of Louisville, was awarded a contract June 14 for 600 escort wagons on bids opened the day previous by Major Theodore B. Hacker, of the United States Quartermaster's Department. The successful bid was \$102.35 each and the delivery time from 60 to 180 days, making the value of the contract \$61,410. The bid was the lowest of eight received. The American Car and Foundry Co., of Jeffersonville, tendered a bid of \$114.89. The highest bid was \$137.50, submitted by George B. Marks, Brooklyn, N. Y. The Louisville firm has made many of these wagons and recently has been working on a big contract. Studebaker's, of South Bend, Ind., were among the unsuccessful bidders, asking \$120.89.

July 1 bids for similar wagons, under identical specifications, will be asked for delivery during the first fiscal year that opens on that date. These bids will be for any quantity from 1,000 to 5,000. This method of asking bids on wagons is an entirely new one. The bidders will be required to give time of delivery.

Hayes Wheel Activities

The Hayes wheel plant, Jackson, Mich., is turning out 700 sets of Ford wheels a day, and, according to the statement of J. M. Aiken, superintendent, fully expects soon to reach a capacity of 1,000 sets of wheels a day.

Twelve carloads of wheels are being shipped from the local plant to the various Ford factories each week. The aggregate output of the large factory is 16,800 wheels a week. A night shift of 30 employes is working in the hub department and other departments are working their full quota of men to keep the capacity up to 700 sets of wheels daily. The output will be increased to 1,000 sets a day by adding more machinery and men. Mr. Aiken says that the greatest difficulty encountered is securing homes for the employes.

The company has purchased the Chaplin Wheel Co., of Chatham, Ont., and will hereafter manufacture in that city under the name of the Hayes Wheel Co.

Troy Co. Gets Big Order for Trailers

The Troy (O.) Wagon Works has received a large order for trailers from the United States government. This, in addition to a \$400,000 order from the French government June 3, assures plenty of employment for all the men that can be secured.

Work on the concrete foundation of the company's new building, which is to be erected to accommodate the growing trailer business, has been begun. It is triangular in shape, the longest side being 160 feet and the shortest 86 feet, and adjoins the building erected last year. The present structure is well adapted for economical production and the new one is to be along similar lines. Work on the building will be rushed as the company has orders in sight to test the full capacity of the trailer plant.

T. M. Sechler Married Fifty Years

Thomas M. Sechler, of Moline, Ill., announces the golden jubilee anniversary of his marriage. Thomas M. Sechler and Juliet A. McCullough were married at Ironton, O., June 7, 1866. Upon the first page of a prettily printed folder is that statement, as well as a photographic reproduction of Mr. and Mrs. Sechler's home at that time, and portraits of the happy couple as they appeared in those days, enclosed in golden medallions. Upon the third page is a half-tone of the house where Mr. and Mrs. Sechler resided, and under it the wording, "Still living at 1702 Sixth avenue, Moline, Ill., June 7, 1916." Mr. and Mrs. Sechler are very well known to the carriage trade, and are regular attendants at the annual conventions of the C. B. N. A.

Durant Becomes President of General Motors

W. C. Durant, who organized the General Motors Co., has recently been elected to the head of this company, taking the place of Charles W. Nash, resigned. Mr. Nash will continue his connection with the company in an advisory capacity until the end of the fiscal year of the company, August 1.

At the same meeting, Albert Strauss, of J. & W. Seligman Co., resigned as a director, and was succeeded by W. C. Leland, vice-president and general manager of the Cadillac Motor Car Co. He served a term on the board in 1910.

Decline in Vehicle Trade

In 1909 the census bureau told us that the average annual production of horse-drawn pleasure vehicles, that is, buggies and carriages, was 843,000 jobs. Up to that time we had not heard much complaint from vehicle interests about the automobile affecting the vehicle trade, and indeed the country trade in motor cars had not reached a large volume. The farmer who drove an automobile in those days was an exception to the rule. Since 1909, however, the sale of motor cars in the country has increased enormously and the general assumption is that the automobile business has prospered at the expense of the horse vehicle trade. This assumption is correct, but judging by the latest census of vehicle manufacturers, the decline in buggy trade has not been as large as generally estimated.

Census figures on production are notoriously inaccurate, but the comparisons made between the productions of different years may be accepted as fairly correct. As late as 1914 an investigation made by the carriage builders' association disclosed that more than 1,000,000 jobs were produced the preceding year, yet the census of 1909 placed the annual production at only 843,000 jobs. But the census probably contained the same mistakes in 1914 that it did in 1909, hence the percentage of decline in carriage production during that five-year period as reported by the census bureau, probably is correct. This reduction is said to be 33 per cent, a decline from 843,000 to 558,000 jobs. The decrease in value was only 30 per cent.

One who has heard what some implement dealers have said about the buggy trade in the last three years would conclude that the business had decreased about 75 per cent instead of 33. It has decreased to that extent so far as a great many dealers are concerned, simply because they have not been giving the trade the attention it received from them in former years. A few years ago, when farmers began to buy automobiles, many dealers practically abandoned the buggy trade. They jumped to the erroneous conclusion that the horse-drawn vehicle business was a thing of the past. The catalog houses did not jump. They are getting a larger share of the trade than they did in former days. The dealers who held on are doing well. One who called on us last week has sold 75 jobs this year.—Farm Implement News.

Can Furnish 9,000 Trucks Monthly

An inquiry has been made by the War Department as to the number of commercial cars of suitable characteristics available in this country on short notice for use by the army. Out of 200 manufacturers approached 113 responded.

It was found that by eliminating trucks that are too light or too weak and those that are too heavy or cumbersome, it would be possible to obtain something like 3,000 trucks a month of a type that will conform in all main essentials to army needs. It also will be possible to obtain 6,000 additional trucks a month of a type that nearly conforms to departmental specifications and that could be used in an emergency.

The specifications, among other things, limit the weight to 5,000 lbs., for the reason that heavier trucks are apt to cut through the crust of roads or break through country bridges and give much trouble generally over such poor roads as are likely to be used.

Gardner Gets Big Body Order

Russell E. Gardner, president of the St. Louis Chevrolet Co., announces that he has obtained the contract for 600,000 Chevrolet bodies because he was favored with barge freight rates on 10,000,000 feet of lumber that will be used in their construction. River barge freight rates figure largely in the distribution of these bodies to assembly plants.

The hardwood will be brought from southern points on river barges which average between 750,000 and 1,000,000 ft. load. The factories to receive bodies from the St. Louis plant are located at Minneapolis, Kansas City, Atlanta, and Oakland, Cal. The Kansas City plant is reached by Missouri river barges, which are in regular operation and the Minneapolis plant by the upper Mississippi barges. The Atlanta and Oakland bodies can be shipped by river to New Orleans and then transhipped by Gulf steamers and through the Panama Canal. The 600,000 bodies are to be delivered at the rate of 200,000 a year.

The St. Louis Chevrolet Co. is now completing additions to each of its two plants, at Broadway and Bulwer and Second and Rutger streets, at a cost of \$50,000 each.

Macauley Now Packard President

At a recent meeting of the stockholders of the Packard Motor Car Co., Alvan Macauley was made president of the company. Mr. Macauley has virtually been president for the past two years, Henry B. Joy having devoted most of his time to military preparedness, and as Mr. Macauley has for some time been performing the duties of the president's office, it was at the request of Mr. Joy that the title of the presidency was given to Mr. Macauley in recognition of his services.

The company also voted to increase its capital by \$5,000,000 common stock at par value, for the purpose of providing additional treasury stock. The new increase gives the company \$13,000,000 of common stock. A modification in the by-laws of the company was also effected to create the office of chairman of the board, which is filled by Henry B. Joy. This change in titles of the officials, however, does not change in any degree the manufacturing policy which has been in effect for over a year.

Du Pont Farikoid Co. Buys Fairfield Rubber Company

The Du Pont Fabrikoid Co. has purchased the Fairfield Rubber Co. with plants at Fairfield, Conn. The Fairfield company manufactures a coat of textile similar to fabrikoid, and is used extensively by automobile and carriage manufacturers.

All the present employes will be retained, the change affecting only the owners. The company will not consolidate with the purchasers, but will continue as the Fairfield Rubber Co. endeavoring to uphold, if not better the present standard of their product.

J. K. Rodgers, sales manager of the Du Pont Fabrikoid Co., will act in the same capacity for the Fairfield company.

The Gaillard Engineering Works, 147 Rogers avenue, Brooklyn, N. Y., has just received a patent on a wheel pulley which they are about to place on the market.

Paige Uses Mechanical Conveyor

The mechanical conveyor system installed in the Paige plant several months ago for the final assembly of cars has been an important factor in the speeding up of production which enables the Paige to show an increase of 300 per cent over this period of the season last year.

The mechanical conveyor is a moving platform several hundred feet long which operates like an endless chain. Cars in embryo are fastened to this platform and they move along one group of workmen to the next as vital parts of the chassis are attached. The rear axle is the first part placed on the platform; the frame, tank, steering wheel, power plant and other parts follow in their proper order and a real car, capable of running off under its own power, emerges from the other end of the conveyor in a surprisingly short time.

A Quick Delivery

Two fleets of Studebaker wagons, a total of 42 vehicles, have just been bought by the United States government. In this connection a record for quick shipments was made by the Studebaker Corporation of South Bend, Ind. Within one week after the order was received the wagons were finished to specifications and sent to their destinations.

The government order consisted of 18 more water wagons in addition to the wagons of the same type ordered recently by the government, and also 24 of the two-yard Ideal dump wagons all equipped with stub poles, horn and bumper and trail chains, making it possible to hook these behind tractors or trucks for transportation in trains across the desert places of Mexico.

Franklin Puts Up Another Addition

Ground has been broken for an extension of the plant of the H. H. Franklin Mfg. Co., in Syracuse, N. Y., which will provide 143,000 additional square feet of floor space. This is the fourth important factory addition started by the company within 12 months.

Upon completion of the building the plant will have facilities for the production of 50 Franklin cars a day.

The structure, to be devoted to general manufacturing operations and the shipping department, will represent an investment of \$500,000, including machinery. It will be three stories high and constructed of reinforced concrete. Provision is to be made for adding three more floors as requirements demand.

The latest Franklin building will span four railroad tracks, permitting all loading under cover.

Bell Company Expanding

The Bell Motor Car Co., which was organized in York, Pa., less than a year ago, for the purpose of manufacturing automobiles, has increased its capitalization to \$1,000,000. The company has just purchased a 15 acre factory site in East York at Rockburn Station, upon which it proposes to erect, between now and the first of the year, modern factory buildings. The company has been placing upon the market this season two models, a pleasure car and a light, 1,000 pound commercial car, equipped with electric lights and starter.

As soon as the new factory buildings are completed this concern expects to be able to provide employment for at least 500 to 1,000 men.

Wagon Works Petitions for Receiver

The Kessler Wagon Works, Aramingo, and Girard avenues, Philadelphia, Pa., through its president, Charles H. Hassert, admitted to Court No. 2 that the corporation is indebted to the extent of \$17,000 and that it would be for the best interests of the creditors and stockholders if a receiver would be given control of the assets.

The admission was made in the form of an answer to the petition of Willis G. Kendig, a stockholder, who asked for the receivership on the ground that the assets would be dissipated if judgment were allowed to be executed by several creditors who threatened to sue out their claims. The assets of the firm are placed at \$40,000. The liabilities of \$17,000 include a \$10,000 mortgage on the corporation's property.

Fifth Avenue Bus Adopts Moline-Knight

The Fifth Avenue Coach Co., New York City, will standardize the Moline-Knight engines for its new equipment exclusively. The company has been experimenting with various types of Knight motors, running over a period of years. All the new equipment will be Moline-Knight motored, and the company's plans are so laid out that production of this equipment will start in July. It now has a few of these machines running.

To Make Automobile Sleepers

The Bradley Mfg. Co., recently incorporated in Tacoma, Wash., will produce a folding berth or automobile sleeper that can be quickly adjusted to any model of automobile, and used for sleeping quarters.

The bed can be adjusted in from three to five minutes and weighs only 30 lbs. It folds up so it can be conveniently placed on the running board of an automobile.

A three-story building near Tacoma will house the new manufacturing plant.

Fiat Auto Factory in Hungary

A branch of the Fiat Automobile Works has been founded in Hungary by the local branch of the Anglo-Austrian Bank and the Fiat Works Limited Co., of Vienna. The capital stock is 1,000,000 crowns (\$203,000). A factory situated at Kelenfold, in the suburbs of Budapest, has been rented. This is being enlarged, and operations will begin in a short time.

Moon's Business Doubled in May

The business of the Moon Motor Car Co., St. Louis, for May was double that of May, 1915, in cars shipped and four times the same month last year in cars ordered. The additional output was handled with only an increase of 33 1/3 per cent in the factory employes. The company has been receiving materials in larger quantities so that it has been able to keep about a month ahead of the demand.

Cincinnati Conventions

Two other conventions will be held in Cincinnati the week the Carriage Builders' National Association meets there. These will be the meetings of the Carriage, Harness and Accessory Traveling Men's Association and the Enamel Leather Manufacturers' Association.

Trade News From Near and Far

Business Changes

J. Wm. Howard has succeeded to the vehicle and implement business of the King Hardware Co., at Carlisle, Ky.

Mullikin & Canno have succeeded to the vehicle, implement and hardware business of Claude Mullikin, Dewey, Okla.

Manford Webb has purchased a half interest in the implement and vehicle business of his father, Chas. T. Webb, at Wingate, Ind. Firm name will now be C. T. Webb & Son.

Lindley & McGonigal, who recently purchased the implement and vehicle business of Brock & Son, at Fairmount, Ind., have disposed of most of the stock at public auction. It is reported that the remainder will probably be moved to Greentown, Ind.

New Firms and Incorporations

Hendrick & Ellis is a new implement and vehicle firm at Martinsville, Ind.

A new carriage factory will be established by W. Griffin, at New Decatur, Ala.

The Rome Supply Co. will engage in the vehicle and implement business at Carrollton, Ga.

P. W. Fox has started up in the implement, vehicle and farm implement business at Jacksonville, Ill.

Colvin & Mosley have engaged in business at Okmulgee, Okla., with a line of vehicles, implements, hardware, etc.

The Stone Hardware Co. has started in business at Hastings, Okla., with a line of vehicles, implements, hardware, etc.

The Fort Pierce Hardware Co. has been organized at Fort Pierce, Fla., for the purpose of dealing in vehicles, implements, etc.

The Arcadia Hardware & Lumber Co. has been incorporated and organized at Arcadia, O. The company will handle heavy farm implements, vehicles, hardware, etc.

News of the Vehicle Trade

The Hickman (Ky.) Wagon Works, owned by S. L. Dodds, will move to Clarksdale, Miss.

Columbia Wagon Co. of Columbia, Pa., is being pushed to the limit to fill orders which include automobile bodies.

The Ringgenberg & Cullison Wagon and Carriage factory at Plymouth, Ind., has moved its quarters, now occupying a larger and more modern building.

The Louisville Wagon Mfg. Co. is increasing the capacity of its automobile department 25 per cent and will soon be in the market for additional machinery.

The Limousine Top Co., Kalamazoo, Mich., manufacturer of automobile tops, has acquired an additional building and will increase its output considerably.

The Maxwell Motor Co., Detroit, automobile manufacturer, is completing improvements to its plant involving

an outlay of \$250,000, which will greatly increase its production.

The Crown Fender Co., Ypsilanti, Mich., will increase its capital stock from \$60,000 to \$100,000. The new plant of this company is nearing completion and is expected to be in operation within a short time.

The Ideal Wheel Co., Massillon, O., has increased its capital stock from \$50,000 to \$150,000, to provide additional capital to erect a new factory building. It manufactures wheels with steel spokes, designed for use on solid rubber tires.

The Chevrolet Motor Co. has acquired a site just outside the city limits of Fort Worth for the new assembling plant which it will build. The building will be of brick and concrete, two stories, containing 150,000 sq. ft. of floor space.

The Safety Automobile Light Co., Knoxville, Tenn., has been organized with \$25,000 capital stock, and contemplates a plant to manufacture a special lamp for automobiles. J. G. Buchanan, A. M. Treadwell, and others, are the incorporators.

The F. S. Carr Rubber Co., of Canada, Ltd., Granby, Quebec, has been incorporated with a capital stock of \$200,000 by James E. Day, 26 Adelaide street west; John M. Ferguson, 46 St. Andrew Gardens; Joseph P. Walch and others, to manufacture rubber goods, automobile tires, etc.

The Thomas B. Jeffery Co., Kenosha, Wis., maker of automobiles and motor trucks, has awarded a contract for erecting additions to cost over \$250,000. Plans are being completed for a 40-ton gray iron foundry, one story, of steel and concrete, 120 x 650 ft., and a body building shop, 150 x 250 ft., four or five stories. Charles T. Jeffery is president and general manager.

The Timken Roller Bearing Co., Canton, O., has placed contracts for two new buildings, one 50 ft. wide, U shaped, the base 105 ft. long and the side sections 220 and 210 ft. in length, three stories. This will be partly for office and manufacturing purposes. The other will be 100 x 105 ft., one story, for factory use. These extensions are in addition to other construction work planned by the Timken interests previously announced.

Doings of Motor Truck Builders

J. B. Barsdale is planning to build a \$50,000 plant for the manufacture of commercial vehicles at Superior, Wis.

The Denneen Motor Co., Cleveland, has acquired the old car shops of the Cleveland Railway Co., Coltman road and East 123d street, which will be used as a temporary location for assembling motor trucks.

The Four Wheel Drive Mfg. Co., Minneapolis, Minn., David W. Henry, president, has purchased the factory buildings of the Nott Fire Engine Co. and expects to inaugurate operations at once in the manufacture of trucks ranging in capacity from two to four tons.

The Kissel Motor Car Co., Hartford, Wis., has completed work on a new three-story building, 84 x 320 ft., and will at once erect another three-story shop, 72 x 316 ft. Plans are also being prepared for a new administration building, four stories. Approximately \$100,000 is being expended.

The American Motor Truck Co. has been incorporated under the laws of Delaware with a capital of \$3,000,000 to manufacture, sell and deal in various kinds of motor trucks, engines and so on. The incorporators are H. H. Walker, Theodore B. Hoy and George E. Touloupoulos, of New York.

The incorporation of the Corliss Motor Truck Co., Corliss, Wis., indicates the establishment of a large commercial car factory at Corliss in the plant formerly occupied by the defunct Wisconsin Engine Co. The corporate articles are signed by members of a law firm of Milwaukee. Capital \$100,000.

Capitalists of New London, Conn., have formed a truck company to produce a truck of standard parts of 1,000 pounds load capacity to be put in the market with the name of the New London truck. One chassis was displayed at a recent show in New London. Details of the company's organization and its plans for production have not yet been made public.

The Thomas Motor Truck Co. has been formed in New York City to build trucks for New York trade and to sell them from factory direct. The parts used will be purchased chiefly in the territory adjacent to New York, and the truck will be designed to meet as fully as possible the operating conditions of that limited territory. Charles K. Thomas, former president of the Federal Motor Truck Co., of New York, is the head of the company. The series of trucks will consist of $\frac{3}{4}$, 1, 1 $\frac{1}{2}$ and 2-ton capacities.

Among the Tire Makers

The Punctureless Auto Tire Co., Akron, has acquired a site in Barberton on which it will erect a plant, 60 x 400 ft., and a power house.

The Double Service Tire & Rubber Co., Akron, is moving to Barberton. The company bought four acres of land and work has started on the new buildings.

The General Tire & Rubber Co. is building a large addition to its plant in Akron. The company was formerly the Western Tire & Rubber Co., Kansas City, Mo.

Excellent progress is being made on the construction of the plant of the Pearce Tire & Rubber Co., Ashtabula. It is expected that the building will be completed by August 1.

Contracts for three new factory buildings for manufacturing, shipping and storehouse purposes have been let by the Federal Rubber Co., Cudahy, Wis. These buildings will be fireproof.

Plans have been completed by Edward Sterns, president of the Efficiency Oil Corporation, and the inventor of the Sterns automobile inner tube, to establish in St. Louis a plant for the Sterns Tire & Tube Co.

The Goodyear Tire & Rubber Co., Akron, has filed papers with the secretary of state increasing its preferred stock from \$7,000,000 to \$25,000,000. The common stock of the company already amounts to \$25,000,000, making a total capital of \$50,000,000.

The Perfection Tire & Motor Co., Niagara Falls, Ont., with plants at Fort Madison, Ia., and Wabash, Ind., is carrying on negotiations with the city council. The company is contemplating the erection of a plant to manufacture automobiles, tires, etc., to cost upward of \$300,000.

Among the Body Manufacturers

The American Body Co., Buffalo, N. Y., will build a \$10,000 addition to its plant at Niagara street.

Schroeder Bros., Milwaukee, are contemplating the establishment of an automobile body plant in Dodgeville, Wis.

The Decatur Carriage Works, Decatur, Ind., have added a line of commercial bodies for automobiles to their products.

Acker & Lyle, Inc., Hackensack, N. J., has been incorporated to manufacture bodies, parts, cars, carriages, etc.; capital \$125,000.

The Elizabeth Auto Body Co., Elizabeth, N. J., will erect a plant, 100 x 100 ft., on South Spring street, and an engine room, 40 x 40 ft.

The Commercial Auto Body Co. has been organized in Chicago with a capital of \$10,000 by Thos. D. Huff, Horace Wright Cook and S. C. Wood.

The Emerson-Brantingham Co., of Rockford, Ill., plan to install about August 1 a department for the manufacture of automobile bodies and fenders.

The Trippensee Mfg. Co., Detroit, Mich., maker of automobile bodies, has increased its capital stock from \$100,000 to \$125,000, for the enlargement of its plant.

Plans have been prepared for the construction of a two-story 95 x 350 ft. factory in Detroit, Mich., for the Wadsworth Mfg. Co., maker of automobile bodies. The estimated cost is \$60,000.

F. C. Kramer, of Savannah, Ga., is about to erect a factory 150 x 200, of steel and reinforced concrete, for the manufacture of commercial bodies and automobile wheels. It is expected that the plant will be ready for operation April 1, 1917.

Henry Goodman, who has managed the New York office of the Springfield Metal Body Co. for two years, has incorporated the Goodman Auto Body Co. and will handle the Springfield business in eastern territory, the change taking effect June 1. He will continue the office at 1737 Broadway. Mr. Goodman, who is president of the new company, was connected with the Pope Mfg. Co. for 18 years.

The Auto Body Co., Lansing, Mich., will increase its capitalization from \$500,000 to \$1,000,000, the increase having been authorized at a meeting of stockholders. A 209 per cent stock dividend was authorized for distribution among stockholders of record July 1, with a cash dividend of 5 per cent June 30. Increase in business for 1916 has necessitated another addition, now in process of building, which will double the shop capacity, and add several hundred men to the present force.

The Leon Rubay Co. has been established in Cleveland, O., with a capital of \$300,000, to manufacture high class bodies for the trade. The plant of the G. D. Hutchcroft & Son Co., body makers, at 1318 West 78th street, has been purchased and will be enlarged. The bodies to be produced will be of the highest type it is possible to manu-

facture in quantities, and will be patterned after special custom designs. Rubay, who is one of the old-timers, was at one time wholesale sales manager for Rothschild & Co., the famous French body makers, and later was with Holbrook & Co., in New York. For the past two years he has been associated with the White Co. in Cleveland as general manager of the pleasure vehicle department.

Personal Mention

N. Walter MacIntyre, for many years associated with the William Young Carriage Co., St. Louis, Mo., has been made general manager of the plant of the Valley Steel Co., a corporation recently formed in East St. Louis.

E. A. Hatfield, for the past five years assistant secretary and sales manager of the Bain Wagon Co., Kenosha, Wis., has resigned his position to take effect July 1. He will move to St. Louis and be associated in a new organization, the Mississippi Valley Motor Car Co., distributors of Oakland cars.

F. J. Walsh, formerly with the Reifling Carriage & Wagon Co., St. Louis, Mo., has joined the M. and N. Auto Equipment Co., local distributors of the Olson Unit, as manager of city sales.

Accessory Manufacturers Merge

The United Motors Corporation, New York City, is an association of leading automobile accessory and parts makers in their respective lines. The capital stock of \$60,000,000 has been fully subscribed.

The companies comprising this merger are the Dayton Engineering Laboratories, New Departure Mfg. Co., Hyatt Roller Bearing Co., Remy Electric Co. and the Perlman Rim Co. These companies will be operated similarly to those now forming the United States Steel corporations. Each will retain its own name and its own organization. The present personnel and scope of operations of each company will be maintained as heretofore. The companies have associated for the purpose of a further constructive development of plants and products. As they stand in this new relation today the companies are backed by the strongest group of bankers in New York.

Alfred P. Sloan, Jr., vice-president and general manager of the Hyatt Roller Bearing Co., at Harrison, N. J., and Detroit, Mich., is its president, and Edward A. Deeds, president of the Dayton Engineering Laboratories Co., of Dayton, O., its vice-president. DeWitt Page, president of the New Departure Mfg. Co., of Bristol, Conn., is secretary and treasurer. These men, together with L. G. Kaufman, president of the Chatham and Phoenix National Bank, of New York City, and S. A. Fletcher, a prominent banker of Indianapolis, Ind., comprise the board of directors.

The president, Mr. Sloan, and the vice-president, Mr. Deeds, will be in entire control of the affairs of the corporation.

Sold Into War

More than \$160,000,000 worth of horses and mules have been exported from this country to Europe since the beginning of the war.

24,000 Carloads of Automobiles Shipped in May

The National Automobile Chamber of Commerce at its monthly meeting in New York City, June 7, reported a return to normal conditions in shipments. May shipments amounted to more than 24,000 carloads, as compared with 15,392 in May last year. Conditions have so improved that the use of flat cars is no longer necessary.

The truck interests also met in convention, the meeting being attended by about 40 makers with Windsor T. White, chairman. Policies of service and repair were adopted, so as to better the conditions of the truck users.

There will be no truck show this year.

The truck committee adopted at its meeting the definition of standard type chassis. Just what is included under the definition has not as yet been completed.

Maxwell to Build Homes

Maxwell Motor Co., which has a plant in Newcastle, Ind., has arranged with the town authorities for a suburban development plan under which houses are to be built and sold to workmen at cost. A company known as the Greater Newcastle Co., has been incorporated with \$100,000 capital. It will take care of dividing a tract of land of 75 acres belonging to the Maxwell Co. into small lots. The city has purchased 10 acres of this land for a park, and the other 65 acres have been cut into 250 building lots, none smaller than 50 x 132 ft. The houses will be sold on a payment of 10 per cent of the cost of construction (\$1,600 to \$1,900) and the remainder in weekly installments of \$5 or \$6.

Wagon Business Increases 25 Per Cent

The Fort Smith Wagon Co., of Fort Smith, Ark., recently reported the volume of business at least 25 per cent increased over one year ago. The company's number of employes and the operating schedule have been increased in about the same proportion as the volume of business. The firm declares that collections are getting fairly good, and in fact last year was a sort of cleaning up year in the south. Many accounts that had been carried over from the year before were paid off. The general feeling is optimistic. The crop outlook is good, and if fair crops and reasonable prices are realized, conditions will be fully normal.

General Motors Doubles Profits

An eight-month financial statement of the General Motors Co., Flint, Mich., shows that its business has nearly doubled. Estimated gross sales up to March 31 totaled \$100,000,000 on the sale of 86,568 cars and trucks. Comparing these with sales of 48,478 cars and trucks during the same period of last year and an income of \$57,362,839 shows an increase in cash of over \$42,000,000. The balance available for common stock is \$17,000,000, as compared with \$9,581,542 last year. The cash balance shows \$3,000,000 in excess of a year ago.

Thermoid Coupling on Velie and Reo

The Thermoid Rubber Co., Trenton, N. J., announces that the Velie Motor Vehicle Co. and the Reo Motor Car Co., Lansing, Mich., have adopted for standard equipment the Thermoid hard fabric flexible coupling.

OBITUARY

L. P. Bannister, 56, died in Chicago, May 25. He had been ill for about a year and had undergone two serious operations. He had been connected with the Muncie Wheel Co. for many years as traveling salesman, and was very popular with the vehicle industry. He was a brother of O. B. Bannister, president of that concern. He leaves a widow and one daughter, 17 years old.

Lowe Emerson, 79, former buggy manufacturer and capitalist, who was a colonel in the commissary department in the Army of the Potomac, died June 2, at the home of his daughter, Mrs. Herbert Aiken, Merryton place, College Hill, Cincinnati. Mr. Emerson made a fortune as one of the first manufacturers of machine-made buggies in Cincinnati, being a member of the firm of Emerson & Fischer.

Charles H. T. Gerstenberg, one of the oldest carriage manufacturers in the eastern district, died May 23, after a brief illness at his home, 96 Taylor street, Brooklyn, N. Y. Mr. Gerstenberg moved to Brooklyn from Manhattan 40 years ago and became identified with the carriage manufacturing business as a member of the firm of H. Duhamel & Co., in Clymer street. Later he branched out for himself and had a factory in Bedford avenue. A few years ago he went back to Clymer street and remained there until his death. Lately he had confined himself largely to the making of automobile bodies. He is survived by his widow and two sons.

John J. Hoover, carriage builder, Lancaster, Pa., had his back broken by the breaking of an elevator, which caused his death on May 27.

William F. Powers, veteran carriage maker of Lansing, Mich., died May 25. About two years ago he suffered a stroke of paralysis and others have followed. Mr. Powers is survived by two sons and five daughters.

Nelson J. Riley, one of the most prominent business men of South Bend, Ind., died May 30, following an illness of more than six months. Mr. Riley moved to South Bend from St. Joseph, Mo., 21 years ago and became connected with the Studebaker Corporation, of which he was later elected vice-president. About a year ago he resigned as assistant secretary of the Studebaker Corporation and was vice-president of the Studebaker Vehicle Works for several years. Mr. Riley was married to Mary Studebaker, daughter of Mr. and Mrs. P. E. Studebaker, in 1882. The widow and three sons survive.

George H. Rolf, 77, retired wagon manufacturer, died June 1 at his home, 838 Clark street, Cincinnati. He located in Cincinnati when 16 years old, coming from Germany.

David R. Snyder, 68, well known wagon and vehicle manufacturer, of Danville, Ill., died on May 26. Mr. Snyder had been in poor health for several years. In 1885 he moved his wagon works to Danville from Auburn, Ind. Eight months ago he was compelled to retire from activity in the concern of D. D. Snyder & Co. Mr. Snyder was born in Pennsylvania. In 1885 his parents removed to Auburn, Ind., where Mr. Snyder and his brother later engaged in the manufacturing of wagons. They afterwards added vehicles. The widow, one son and one daughter survive.

Horse and Vehicle Exports

Exports of commercial vehicles and horses since the beginning of the war amounted to about \$350,000,000. Of this sum \$160,000,000 was spent for horses and mules, of which \$130,000,000 was for horses and the remainder for mules. Of the \$160,000,000 represented in motor cars, about \$100,000,000 was spent for commercial vehicles and \$60,000,000 for passenger cars. France is the greatest consumer of the animals, 122,000 being estimated as the consumption of that country alone. England has taken 38,000 and Canada 77,000.

WANTS

Help and situation wanted advertisements, 1 cent a word; all other advertisements in this department, 5 cents a word; initials and figures count as words. Minimum price, 30 cents for each advertisement.

FOR SALE

For Sale—Wagons and feed trucks. Max Beigelman, 706 Pacific street, Brooklyn, N. Y.

PATENTS

Patents—H. W. T. Jenner, patent attorney and mechanical expert, 606 F St., Washington, D. C. Established 1883. I make a free examination and report if a patent can be had and exactly what it will cost. Send for circular.

Index To Advertisers

Acme Rubber Mfg. Co.....	1
Cargill Co., The.....	3d cover
Carter, Geo. R., The, Co.....	36
Columbus Bolt Works.....	4th cover
Correspondence School of Carriage and Motor Carriage Drafting	36
Dowler, Chas. L.....	36
Eccles, Richard, Co.....	36
Fairfield Rubber Co.....	36
FitzGibbon & Crisp.....	4th cover
International Rubber Co.....	36
Lawson Co., F. H., The.....	1
Landers Bros. Co.....	36
Mulholland Co., The.....	36
O'Bannon Corporation	1
Payne Co., E. Scott.....	36
Porter, H. K.....	36
Sheldon Axle and Spring Co.....	2d cover
Standard Wheel Co.....	4th cover
Standard Oil Cloth Co., Inc., The.....	2
Technical School for Carriage Draftsmen and Mechanics	3d cover
Wilcox, D., Mfg. Co., The.....	2d cover
Willey Co., C. A.....	1
West Tire Setter Co.....	2d cover
White-Quehl Mfg. Co.....	36

BUSY BUYERS BRIEFS

CHARLES L. DOWLER
 CARRIAGE AND WAGON HARDWARE
 108 North Third St., Philadelphia, Pa.
CUSHION MANUFACTURER
 Pure Stearic Acid Candles. Wheel Stock. Snow
 Flake Axle Grease.

Buckram, Webbing,
 Mohair, Bow Lining and Strain Straps,
COLORS TO MATCH
 Burlap, Transparent Celluloid, Sheetings
 and Cushion Canvas.
 We Guarantee prompt shipments, best goods, lowest prices.
Landers Bros. Co., Toledo, Ohio

**MULHOLLAND
 BUGGY SPRING**
 Reduces weight of springs one-half.
 Made in one size only but will fit bodies
 of all widths.
 Write for further particulars and prices.
THE MULHOLLAND CO. DUNKIRK, N. Y.

White's Brazing Sleeves
 For applying Rubber Tires
 Send for Samples.
WHITE-QUEHL MFG. CO.
 431 E. Pearl St.
 CINCINNATI, OHIO

E. SCOTT PAYNE CO.
 Carriage and Automobile
HARDWARE
 Horse - Shoers' Supplies
 362-364 North Gay St., Baltimore, Md.

Automobile and Carriage Leathers,
Leather Welts and Gimps
 All Kinds of Leather Specialties
 WRITE US FOR PRICES
THE GEO. R. CARTER CO.
 CONNERSVILLE, IND.

**Results Always Follow
 Advertising in
 THE HUB**

**It Pays
 Others
 It Should
 Pay You**

PORTER'S BOLT CLIPPERS
 "Easy" "New Easy" Allen-Randall



To Cut 5-16, 3-8, 1-2, 5-8, 3-4 Inch.
H. K. PORTER, EVERETT, MASS.

CARRIAGE—WAGON—AUTOMOBILE
 AND SPECIAL
DROP FORGINGS
 QUALITY—THE
 BEST
Richard Eccles Co., Auburn, N. Y.
 PROMPT SERVICE.
 WRITE FOR CATALOG.
 SEND BLUE-PRINTS OR MODELS
 FOR OUR QUOTATIONS—IT WILL PAY YOU

THE FAIRFIELD RUBBER COMPANY

Manufacturers of

**Carriage Cloth, Imitation Leather,
 Automobile Cloths, etc.**

FAIRFIELD, CONNECTICUT

Established 1886

**Correspondence School of Carriage and Motor
 Carriage Drafting**

A thorough, practical tuition is given through this correspondence school. The theory and practice of construction, bookkeeping, perspective. Many men now hold good positions through taking the courses of instruction.

Principal, **THOS. MATTISON,**
 Hillside Avenue, Bitterne Park,
 Southampton, England

Author of "The Coach Body Makers' Guide," \$3.00; a practical treatise on "The Suspension of Carriages," "Bookkeeping," and other carriage building works.

"INTERNATIONAL" RUBBER CARRIAGE CLOTH

The Rubber Carriage Cloth of **SERVICE** and **QUALITY**
INTERNATIONAL RUBBER CO.

Write for Samples and Prices
225 Fifth Avenue, New York

Carriage Mechanics

Desiring to improve their present
Condition should attend the

TECHNICAL SCHOOL

FOR

Carriage Draftsmen and Mechanics

SUPPORTED BY THE

Carriage Builders' National Ass'n

The object of the School is to teach men to design vehicles and make working drawings, and to otherwise facilitate their work in the shop. Only those men employed in carriage or automobile building or their accessory trades are admitted to its privileges.

The classes are conducted in three divisions, viz.: Corresponding, Day, and Evening. The former is open during the entire year, while the day and evening classes are in session only from October 1 to April 1.

The tuition is moderate.

For prospectus and full particulars, write to the instructor,

ANDREW F. JOHNSON,

20 West Forty-fourth St.,
NEW YORK CITY

Cargill Service

has brought to the Cargill Company more Vehicle Catalogues than are made by any other printing house in America.

Cargill Quality is bringing The Best Automobile Catalogues to our plant for Complete production—watch for our imprint in the Season's best books.

THE CARGILL COMPANY

DESIGNERS
ENGRAVERS



PRINTERS
& BINDERS

Grand Rapids, Michigan

WHAT IT IS

The American Harness and Saddlery Directory

The 1915 Edition

An extra painstaking revision of the names (and other information as below) constituting the Retail Harness Trade, has been completed for this year's issue of the Directory, and we think the work is so important and worthy that the

1915 Price is \$5 Per Copy

and it is very moderate for what is offered in a work that is

Indispensable for Reference

for copying of addresses, and for all purposes usual in a directory.

Just a Sketch of Its Contents

The list of the **WHOLESALE** and **JOBGING TRADE** is so arranged as to make it convenient to separate the association members from those not so recognized.

The **RETAIL HARNESS MAKERS** of the United States and Canada comprise the principal part of the Directory, arranged by State, Town and County, and in the large cities, the street and number is given. Those rating (approximately) over \$1,000 are marked.

A list of **HARNESS DEALERS** as distinguished from retail harness manufacturers, is also given. The value of this list to those who solicit the vehicle, implement, hardware and department stores will be readily appreciated.

A list is also published of Export Commission Merchants, giving the class of merchandise they handle.

PUBLISHED BY

THE TRADE NEWS PUBLISHING COMPANY

PUBLISHERS OF "HARNESS"

EDISON BLDG., COR. ELM AND DUANE STS., NEW YORK

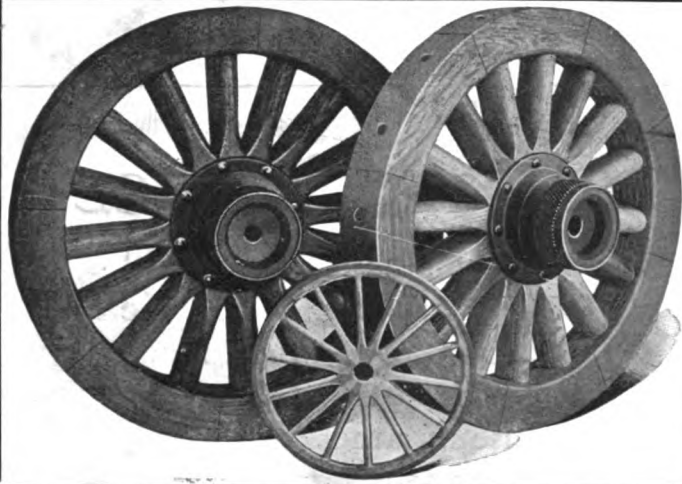

Standard Wheel Co.

Terre Haute, Ind.

Manufacture all kinds and all sizes of Wheels for Carriages, Wagons and Motor Vehicles

Quality First

DOEHLER DIE-CASTINGS IN ALUMINUM

have been developed to a high state of efficiency. They have all the qualities that characterize our well known White Metal product with the additional features of being light in weight and possessing great tensile strength. Being delivered practically ready for assembling as accurate in most details as a machined product, they are extensively used by the most prominent Automobile Manufacturers in preference to machined parts—saving thereby the enormous "overhead" entailed by maintenance of costly machining equipment.

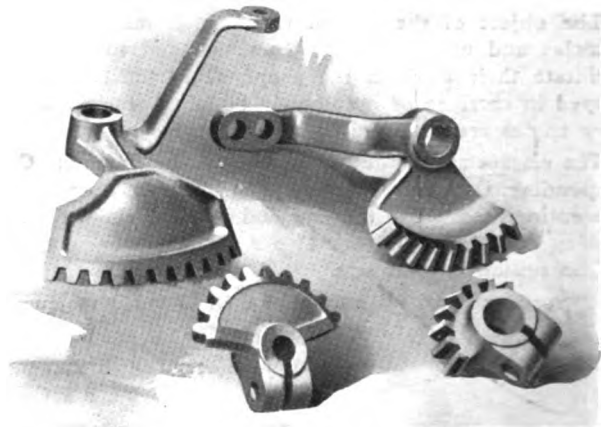

Aluminum die-cast control gears

DOEHLER DIE-CASTING CO.
BROOKLYN. N.Y.
NEWARK. N.J. TOLEDO. OHIO.

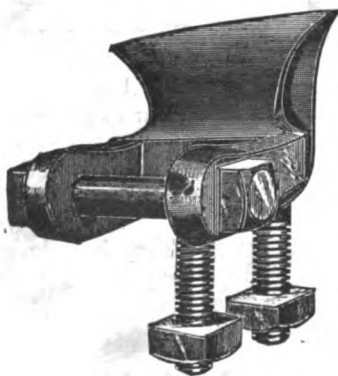

Skewed Shaft Couplings

**Regular or Oval Patterns
For High Arched Axles**

Furnished in rights and lefts for any height of arch. Oval Axle Clips $\frac{5}{8}$ or $\frac{3}{4}$ width to match Oval Couplings. Bolts, Clips, Couplings, Carriage Hardware and Special Forgings

Catalogue "H" and Prices on Application

COLUMBUS BOLT WORKS COMPANY
COLUMBUS, OHIO

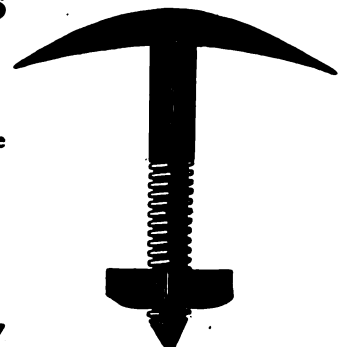

The Hub

First Journal of the Vehicle Industry

Vol. LVIII

AUGUST, 1916

No. 5

The last word in motor car equipment

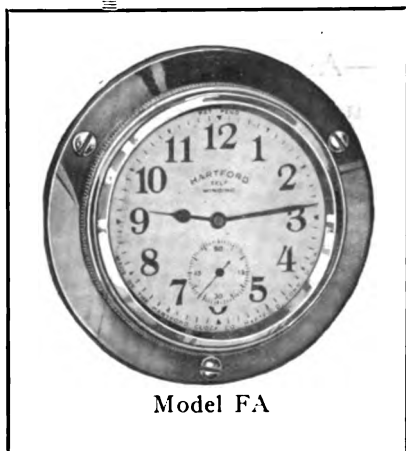

Model FA

The HARTFORD ELECTRIC

Self Winding Clock

*It is ACCURATE
It is RELIABLE*

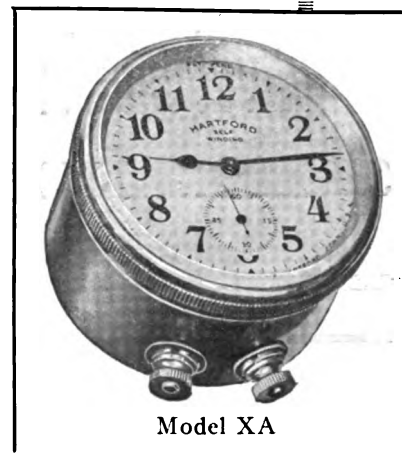

Model XA

Operates from your storage battery or on FOUR No. 6 Dry Cells.

A wonder clock that needs no attention.

Put it on your car, connect two wires to it and you will have the time, the right time and nothing other than the right time, all the time.

No keys are required—neither does it have to be taken apart to wind.

It is immune to the effects of vibration, heat, cold and is dust proof.

The HARTFORD ELECTRIC SELF WINDING CLOCK contains a *seven jewelled* watch movement of highest quality especially designed to meet the severe conditions to which an automobile timepiece is subjected.

The HARTFORD CLOCK is guaranteed for one year.

Made in two styles

Model FA Flush Inset type

Model XA Extended type

Either Model in all nickel
or all black with black or
silver dials

Price \$10.00

Manufactured by

THE HARTFORD CLOCK COMPANY, INC.

6 CHURCH STREET, NEW YORK CITY

Descriptive catalog for the asking

SHELDON AXLES AND SPRINGS

**For Horse-Drawn and Power-Propelled
Vehicles of All Kinds**

JUST ENOUGH BETTER THAN OTHERS TO BE NOTICEABLE

When you specify "*Sheldon*" you are not experimenting with experiments, but are getting Axles and Springs with years of manufacturing experience back of them—Axles and Springs that are selected for important work where conditions make reliability supremely important

SHELDON AXLE AND SPRING COMPANY, WILKES-BARRE, PA.

LARGEST AXLE AND SPRING FACTORY IN THE WORLD

AUTOMOBILE BODIES

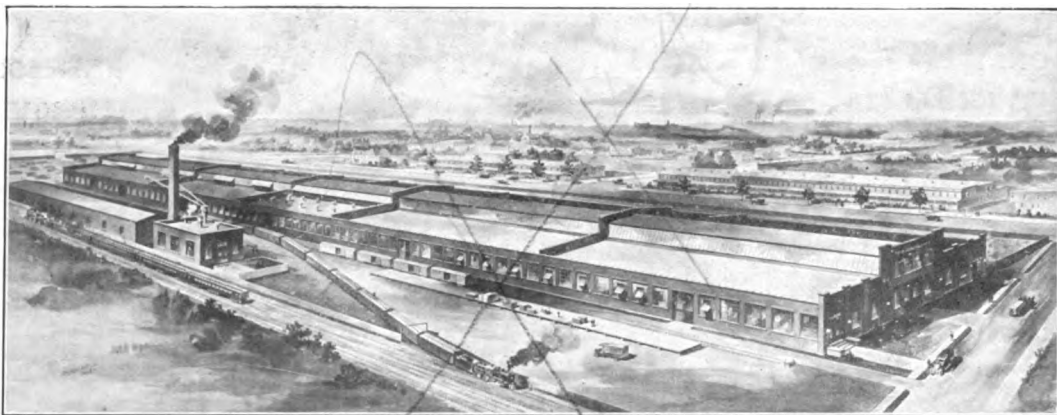

A large corps of skilled workmen and a factory with special equipment and facilities to produce high grade work at reasonable prices

Exclusive designs sent upon request

FITZGIBBON & CRISP, Inc.

Trenton

New Jersey

There is a size that will successfully meet your exact requirements

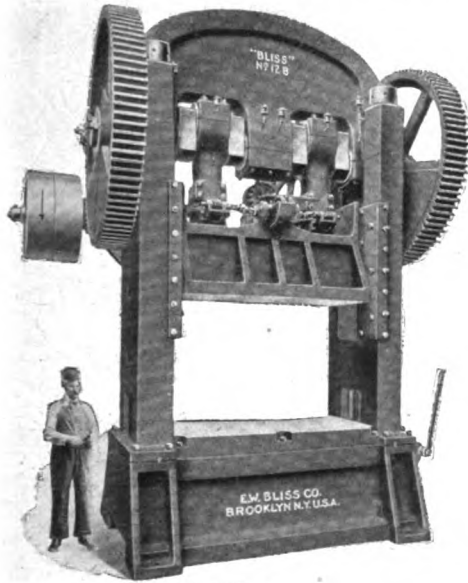

Presses with correct proportions for use in the manufacture of large sheet iron and steel goods. The large diameter shafts and well-gibbed sides allow quantity production that's profitable.

Bliss Double-Crank Presses

Adapted for the economical production of vapor stoves, wrought iron ranges, agricultural implements, automobile stampings, steel car parts, ceilings, sidings, metal doors, window frames and sashes, metal furniture and similar goods.

Built in over 150 sizes, there is one adapted to your special requirements. Write today for descriptive matter.

Talk to us about presses for any and every requirement

E. W. BLISS CO.

38 Adams St., Brooklyn, N. Y.

Chicago Office: 622 West Washington Boulevard.
Detroit Office: Dime Bank Building.

Save money. Dispense with costly machine work wherever possible. Use

Acme Die Castings

For the Vehicle and Automobile Trade

Acme Die Castings are made under pressure in carefully-cut steel molds, and are accurate to the thousandth part of an inch—all alike, ready to assemble as soon as received.

The superiority of Acme Die Castings is greatly due to our patented casting machines, which have exclusive features in the treatment of metals and in the regulation of speed, temperature and pressure. Acme Dies are guaranteed for an unlimited number of castings, and Acme Die Casting Machines are

very rapid, insuring prompt delivery of parts in any desired quantity.

Our die-casting experts are ready to aid you in securing the full economies and advantages of the die-casting process as applied to YOUR product. This is a part of ACME SERVICE—to render the same kind of co-operation as though our factory were a department of your own business, and to **deliver the parts**—when you want them and how you want them.

Compare a sample with others

Acme Die Casting Corporation
Bush Terminal Building, No. 5
35th St. and Third Ave., Brooklyn, N. Y.



SALES OFFICES

Boston.....176 Federal St.
Philadelphia.....Widener Bldg.
Detroit.....965 Woodward Ave.
Chicago.....232 S. Clark St.

W H E E L S

We Manufacture
Light—Medium—Heavy

Shortsville Quality

W H E E L S

Do not arrange for next
year's supply without
first writing us for prices

(New Corporation)

Shortsville Wheel Co.

Shortsville, N. Y.

WILLEY'S COLORS

The **RECOGNIZED STANDARD**



C. A. WILLEY CO.

COLOR GRINDERS

and Manufacturers of Specialties in

CARRIAGE, AUTOMOBILE AND CAR

PAINTS

COLORS, VARNISHES, ETC.

HUNTER'S POINT, NEW YORK CITY

SHERWIN-WILLIAMS VEHICLE FINISHES

A PRODUCT FOR EVERY PURPOSE, PRODUCING DISTINCTIVE RESULTS

S-W METAL PRIMERS S-W BODY AND GEAR UNDERCOATINGS

S-W Q. D. COLORS S-W COLOR VARNISHES

S-W FINISHING VARNISHES

EFFICIENT IN QUALITY AND UNIFORMITY

The Sherwin-Williams Co.

CLEVELAND

CHICAGO

NEWARK

MONTREAL

LONDON, ENG.



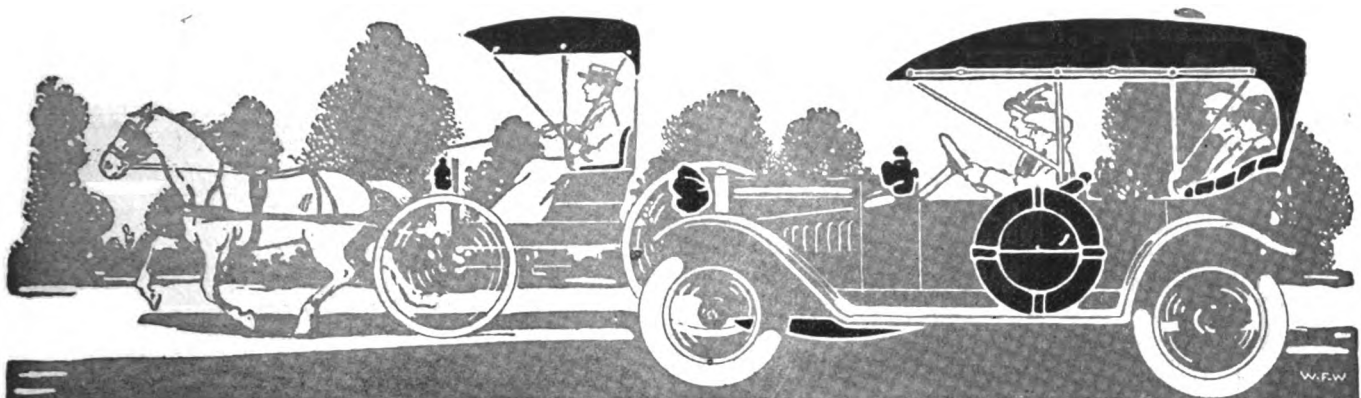

The Leading Leather Substitute For Carriage and Auto Trade

When you need a leather substitute, join the other progressive carriage and automobile manufacturers and select the leading leather substitute—

MERITAS

LEATHER CLOTH

A leather substitute is but a substitute after all—but Meritas leather cloth is made and finished to withstand the hardest wear and handling.

Meritas Leather Cloth is durable, of non-cracking finish and guaranteed perfect by our trademark stamped on the back of every yard. You will like the selection of colors and the lasting finish of this serviceable leather substitute.

Meritas Leather Cloth is made in muslin, duck and drill; dull or glazed; smooth or grained; in black and colors.

Learn more about this leading leather substitute by writing for sample book—sent on request.

Write
for
sample
book of
MERITAS
LEATHER CLOTH
NOW

The Standard Oil Cloth Co., Inc.

320 Broadway, New York

Material and Labor-Saving Devices Which Accomplish Their Purpose



prolong the life service of your solid forged tools many fold by reducing and utilizing their discarded ends in

Williams' "AGRIPPA" Tool Holders "THE HOLDERS THAT HOLD"

Instead of keeping one machine busy on part time keep all machines busy on full time with the same steel. Avoid all forging, hardening, tempering and most grinding expense.

Produce cutting edges where, when and how you need them, eliminating superfluous handling, annoying delays and costly mistakes.

HARD HEADED "AGRIPPAS," new or old, provide adequate bearing for their cutters and their fastenings, substantially housed, are practically indestructible.

Small cutter requirements minimize the burden of procuring high-speed steel.

Pamphlet
for
the
Asking

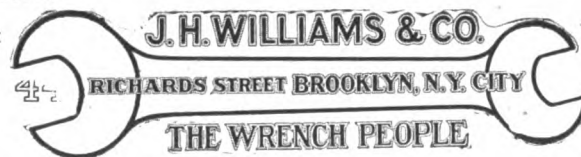

All
Tools
Guaran-
teed

The Hub

Vol. LVIII

AUGUST, 1916

No. 5

Published Monthly by

THE TRADE NEWS PUBLISHING CO. OF N. Y.

PAUL MORSE RICHARDS, *President* G. A. TANNER, *Secretary and Treasurer*
EDISON BUILDING, COR. ELM AND DUANE STS., NEW YORK

THE HUB, a monthly authoritative journal on all subjects pertaining to the vehicle industry from its engineering and construction viewpoints. It publishes information of live interest to manufacturers of motor vehicles, trailers, carriages, wagons, the accessory trades, repair shops and garages.

Subscription price for the United States, Mexico, Cuba, Porto Rico, Guam, the Philippines, and the Hawaiian Islands, \$2.00; Canada, \$2.50; payable strictly in advance. Single copies, 25 cents. Remittances at risk of subscriber, unless by registered letter, or by draft, check, express or post-office order, payable to the order of THE TRADE NEWS PUBLISHING CO.

For advertising rates apply to the publishers. Advertisements must be acceptable to publishers. Copy for new advertisements must be received by the 25th of the preceding month. All communications must be accompanied by the full name and address of writer.

Entered in the New York Post Office as Second-class Matter

A National Problem

The threatened railroad strike is the most disquieting thing that has appeared on the industrial horizon of this country in a long time. The tying up of a nation's transportation system is a national calamity. It affects every person in the country. It paralyzes business and everything has to stop, pending a settlement. It is almost as though all our public roads were blocked. A railroad strike is not like a strike in a factory that affects primarily the owners of the shop and their employes. It is a national affair and steps will have to be taken some time whereby the public will be empowered to assert its rights. It is too big a national problem to be left solely in the hands of a few people who may have grievances against each other. If the only solution should be national ownership even that step will have to be taken. Our transportation system is a part of our national existence and a vital part to every person in the country. It must not be at the mercy of either organized capital or organized labor no matter which side is right in the present controversy.

Auto Exports for First Six Months

The exports of automobiles during the fiscal year ended June 30, 1916, reached a total of 77,496 machines, valued at \$97,464,381, together with parts, not including engines and tires, to the value of \$22,536,485, according to figures compiled by the Department of Commerce. During the fiscal year the exports were classified as follows: Commercial cars, 21,265, valued at \$56,805,548; passenger cars, 56,231, valued at \$40,658,833. During the fiscal year of 1915 there were 37,876 machines exported, the value being \$60,254,635, the exports consisting of 13,996 commercial cars, valued at \$39,140,682, and 28,880 passenger cars, valued at \$21,113,953.

While the year's total mounted high the figures show

a decided falling off during June as compared with the same month of last year. During June last, 1,416 commercial cars, valued at \$3,551,148; and 4,905 passenger cars, valued at \$3,416,396, were shipped abroad, together with parts, not including engines and tires, to the value of \$1,886,746. In June a year ago the exports consisted of 2,990 commercial cars, valued at \$8,578,802, and 4,418 passenger cars, valued at \$3,785,998.

Canada was the largest customer for passenger cars, taking 1,145, with British South Africa second with 553 and France third with 408. Among the South American countries, Argentina made the best showing, taking 369, while Venezuela bought 91, Chile 70, and Brazil, 47.

What America Lacks in Fight for Trade

Secretary of Commerce Redfield, in an authorized interview, "Waste," in *The Nation's Business*, says:

"The German has applied science to business as no other nation has ever done, and he has added to the sciences of research the equally important science of organization.

"The Englishman has brought to his business a certain type of bulldog courage, backed by the largest amount of free capital the world has ever seen gathered in the hands of any one people, and he has sold all round the world to industries and customers kindred to himself as no other people has ever been able to do.

"We have lacked the science; we have lacked the organization; we have lacked the free capital."

Machine Shops Doing Car Repairing

A comparatively new business is the repairing of motor cars and motor trucks in shops specially equipped with machinery for the work and having a corps of expert workmen thoroughly familiar with the intricacies of the various makes of cars. These establishments can give service incomparably superior to the ordinary garage, as they have machine tools that enable them to make repair parts quickly when not in stock. Not all the work is of an emergency nature, and in a large shop, overhauling from the ground up can be done economically by switching the men to hurry-up jobs as required. In some places manufacturing on a small scale enables the equipment to be profitably employed in slack time.

The figures for our foreign trade in the fiscal year ended June 30 last have been given out by the Department of Commerce. They show exports of \$4,334,000,000, imports of \$2,198,000,000, and a balance on merchandise account of \$2,136,000,000. The month of June contributed \$219,000,000 to this balance, being second to the month of May, when the balance was \$245,692,298.

Practical Training of Apprentices

Many employers, it should be said to their credit, are thoroughly alive to the necessity of apprenticeship training and are doing all they can individually, by action in their own shops and by making their voices heard in employers' conventions and elsewhere, to awaken their fellow employers to this industrial need. It is nevertheless a fact that most employers are giving little heed to the subject.

The average employer, not from necessity but because of thoughtlessness or habit, still prefers to get workmen whom some one else has trained. When he employs one or more boys, he does so not for the purpose of making them skilled workers, but because there is a certain amount of "boy work" about the place which can be done cheaply by boys. There is not only a widespread indifference among employers to the proper training of young workers, but there is often a selfish objection to it. Many employers make the excuse that there is not sufficient time to teach boys the trade; consequently, they refuse to employ inexperienced young people, preferring to leave their training to others. These employers demand experienced workers and will take no others, except that they employ boys for boy jobs, and do not give even these a proper chance for advancement, so that they have to migrate to other places where such chance is given, or remain forever in the "lumper" class.

From whatever point of view one considers such an "apprenticeship," says American Industries, it must be admitted that it does not meet the requirements of the industry, the needs of youth, nor the best interests of the employer. Such system or lack of system discloses the indifference of the employer, lack of forethought on the part of the boy and his parents, and a downright betrayal of apprenticeship education which should not be permitted in any enlightened community. This condition unfortunately gives some basis for the frequent condemnation of workshop training.

When trade instruction is given in public trade schools, it must be clearly understood that this type of education must be differentiated from the trade training which can be obtained in the shop, as the public trade school can teach only part of the required technic; the remainder must be acquired through practice on actual work under trade and commercial conditions. In the case of trade instruction through apprenticeship, on the other hand, the public school can effectively supplement shop study and shop work through correlated continuation instruction, even though the shop apprenticeship system provides, as it should, for trade training through practice in actual work and for applied instruction in related sciences, in order to develop both a mastery of the trade and an industrial understanding and intelligence.

Market for Autos in Danish West Indies

The recent introduction into St. Thomas, Danish West Indies, of two low priced American automobiles, which are the first seen on the island, except at two or three brief exhibitions in years past, appears to have aroused interest in the project of extending and improving the roads there. The total length of the St. Thomas roads does not exceed 15 miles, and consequently any idea of adding to the present small number of motor cars is quite out of the question for the time being. Both of the ma-

chines mentioned are hired from time to time by local residents or by tourists, and one of them, owned by the St. Thomas Ship Brokers' Association, is employed by its owners in connection with large shipping interests.

Better Roads on St. Croix—Customs Charges

In the neighboring island of St. John there are hardly any good carriage roads. In St. Croix, however, the carriage and automobile roads are said to total about 100 miles in length, and there are 19 automobiles on that island. The first of these was imported 4½ years ago. One large motor truck in St. Croix is employed in carting sugar from a sugar factory to the wharf at Frederiksted.

The customs duty on automobiles imported into St. Thomas is 6 per cent ad valorem, while the duty levied in St. Croix on automobiles and their accessories amounts to 12½ per cent ad valorem.

The St. Croix roads are not especially good for automobiling, and the machines usually desired are those of a light make. The planters and others who might become purchasers cannot be styled wealthy, and cheapness is another important consideration. There should be an opportunity in the near future to increase the number of automobiles in St. Croix to a limited figure, provided the present high prices paid for sugar continue until the entire crop is sold.

Motor Car Hoods With Glass Panels

Automobiles with hoods in which plate glass panels have been inserted are being used by motor car salesmen, and others, as a novelty and for advertising purposes. In some instances the interior of the hood is lighted at night with hidden electric bulbs. Such a machine standing at the street curb is sure to attract the attention of passers-by. An engine, for example, which does not throw any oil shows off to very good advantage under a hood of this character, the inside of the glass remaining clean with very little attention. In certain cases car owners have used glass panels molded to fit the curves of the hood. This produces an elegance of finish that is very pleasing to the eye.

Automobiles in the Netherlands

The number of automobiles in the Netherlands, while still relatively small, has doubled in the last four years. It is now 7 000—not large for a population of 6,000,000, but the increase is noteworthy. It would have been still greater had not the war caused serious difficulties, especially in importing tires. Many people refrain from buying automobiles simply because no guaranty can be furnished that they will have a continuous supply of tires.

There is a promising market in the Netherlands for American automobiles. Several agencies in Amsterdam have done good business in them, and will doubtless do still better when the close of the war removes present obstacles.

Makes Handling Easy

Realizing the difficulty of handling heavy rolls of material, especially where saleswomen are employed, the Du Pont Fabrikoid Co. is supplying the trade with a handsomely constructed display rack for use in showing Craftsman Quality Fabrikoid. It holds up to 20 rolls or half rolls on rollers, making display and handling easy.

Welding Aluminum Automobile Bodies*

Savings in Labor and Material Effected by Oxy-Acetylene Process--A Special Flux Applied Wet With a Brush

By C. R. Sutton

In the palmy days of the horse-drawn vehicle, Amesbury, Mass., was the mecca for the carriage industry. With the advent of the automobile what was more natural than the development of an industry more in keeping with the trend of the times? The carriage industry in the Amesbury of today is to a large extent replaced by fac-

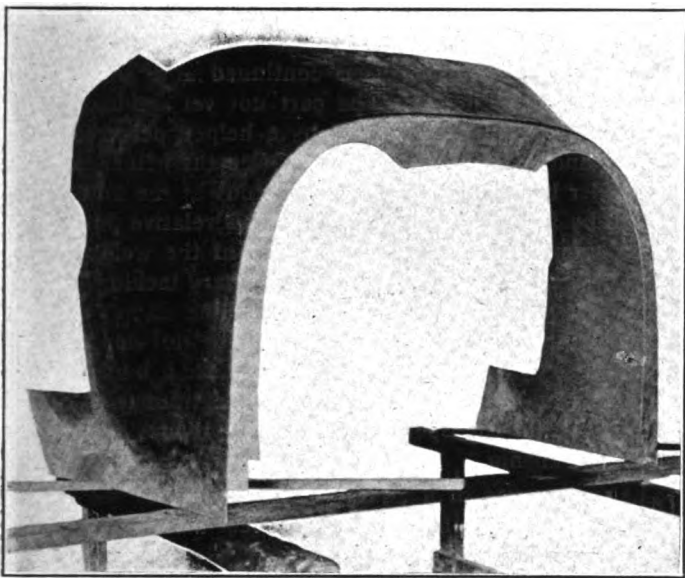

Fig. 1—The cowl, hammered to shape with very little metal formed over the front

tories devoted to the manufacture of automobile bodies, their product outrivaling in fitness of appointments and fineness of finish and design the most luxurious wooden coaches of old.

In Amesbury some rather remarkable methods of aluminum body construction have been developed which have made possible radical departures in design, savings of material through the more economical cutting of patterns and savings in actual labor costs as well. Oxy-acetylene welding plays an important part in this new type of body construction at the plant of the Walker-Wells Co., a development of the Walker Carriage Co., manufacturer of carriages for more than 25 years.

In the manufacture of the Franklin roadster body the back quarter panels, consisting of a single piece of sheet aluminum extending from the door opening on one side around both quarters and across the back could be constructed in no other way except by welding. The entire section, welded into one solid piece without a seam in four minutes, is shown in Fig. 4. The unpainted Winton Berlin body is another example of the saving effected by oxy-acetylene welding. The top of this body is constructed of aluminum, and is welded to the back panel to form one continuous piece. The top, as well as the various other

parts, may be made up from several plates welded together, which obviates the necessity of using large sheets of aluminum, thereby reducing the cost, and in some cases permitting the use of various small pieces of sheet aluminum that would otherwise become scrap, again effecting a considerable saving. The construction of a center post panel from four pieces of stock of odd sizes is shown in Fig. 5. Welding time on this type of panel construction is five minutes.

The forming of the cowl on the Franklin bodies formerly presented many difficulties, due to the large amount of metal that must be formed and swaged over the front to form the front panel. This difficulty has been overcome by the welding process, as shown in Figs. 1, 2, and 3. Fig. 1 illustrates the cowl hammered to shape with very little metal formed over the front. The remainder of the front panel is made up by welding in small side sections or wings, as shown in Fig. 2. Fig. 3 shows the completed part, the front panel sections now conforming with the characteristic lines of the Franklin hood. The total length of this weld is approximately 60 in. and the total welding time for both sides is seven minutes.

A view of the Franklin roadster rear boot, welded into one solid piece, is given in Fig. 6. The total time for these two welds is seven minutes. The same class of work on a coupe rear boot requires a much shorter time, only five minutes, for welding. Welding of this character is carried out with the separate parts clamped on a frame, as shown in Fig. 7.

Another operation which formerly presented difficulties



Fig. 2—Welding in front panels of cowl and method of holding sheets

in automobile body manufacture is the forming of door panels around the window frame openings. This was formerly handled by slowly hammering the metal over the frame and carefully working in the corners, the process

*This article and illustrations reproduced through the courtesy of The Iron Age.

occupying a total time of over $2\frac{1}{2}$ and sometimes 3 hours. Even by proceeding slowly and exercising the greatest care in the forming of the metal at the corners, it was found that cracks would appear at various places in the metal, due to the strain of working the metal cold. A considerable loss of material was the result in a great many instances. This difficulty is now overcome by using a small acetylene blow-torch, which is similar in principle to the well known Bunsen burner. The metal is simultaneously annealed and hammered by one man, as shown in Fig. 9. In this case the same cylinder of acetylene that is ordinarily used with the oxy-acetylene outfit is now

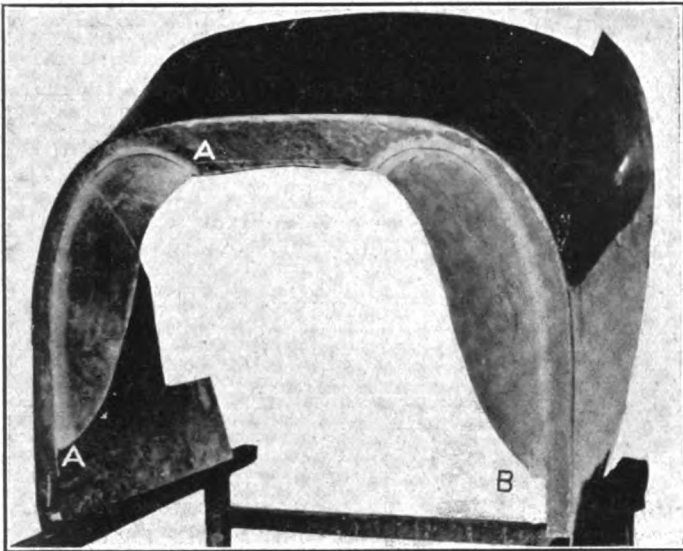

Fig. 3—The cowl with front panels welded in place at A and B in seven minutes

employed to furnish gas for the annealing and hammering operation. The total time occupied by this newer method is 30 minutes, at a time cost of less than one-fifth of what the old method of hammering cold formerly cost, and with practically no loss.

A striking example of the savings that are being made in the laying out of patterns on aluminum sheets is given in Fig. 8. The illustration is of a Sedan cowl, roughly shaped, with small pieces welded to the corners, a considerable saving in the size of the sheet necessary for this pattern. The total time consumed in welding the

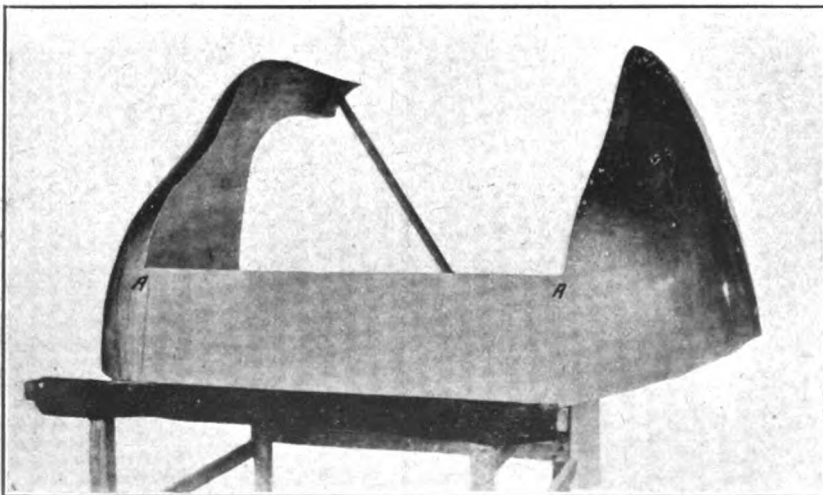

Fig. 4—Back quarter panels of a Franklin roadster extending from the door opening on one side around both quarters and across the back, which was welded into one piece at A in four minutes

two corners A and B was five minutes. Various other parts not illustrated are welded in this interesting industry, and the oxy-acetylene process also finds many other important uses on general welding work about the plant.

For the benefit of those who are not familiar with the welding process, a detailed explanation of the method of proceeding with this class of sheet aluminum welding will doubtless prove interesting and instructive. In the majority of operations the edges of the sheets to be welded are turned at right angles to a height of from one-and-one-half to twice the thickness of the metal. After applying a flux to cause the metal to flow freely, these upturned edges are brought together and held with clamp tongs, such as are being used by the operator in Fig. 2. A short section of a few inches is then welded. This welded section is allowed to cool thoroughly before removing the clamp, otherwise a crack would develop which might follow the subsequent welding, as aluminum, when subjected to intense heat, is very fragile. The tongs are then moved a few inches along the line of the weld and the metal welded to that point. This is continued until the entire section has been joined. The part not yet welded is allowed to hang free, or is held by a helper, according to the size and shape of the sheets. Often the helper assists the welder by manipulating the free ends of the unwelded portion by bringing them into their true relative positions as the clamp is moved along the line of the weld in advance of the welding operator. Preliminary tacking of the joint at regular intervals with the welding flame, except at the point where the weld is begun, is not considered good practice, as it has a tendency to cause a buckling of the sheets as the weld progresses, which interferes with the progress of the operator and nearly always results in bad workmanship.

The proper use of a fluxing agent is one of the most important points to be watched in sheet aluminum welding. Its improper application nearly always results in imperfect work. The following information will prove useful to welders engaged on sheet aluminum work. A special sheet aluminum flux, mixed with water to the consistency of cream, is applied to the line of the weld by a stiff brush similar to a painter's sash tool. After the weld has been completed the flux is washed off either with a scrubbing brush or, as is more commonly the case, with a bunch of waste soaked in cold water, the water

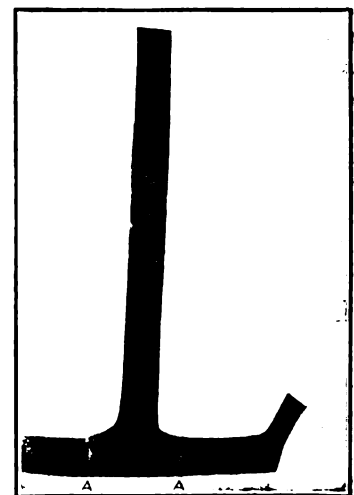

Fig. 5—A center post panel welded at A from odd stock in five minutes

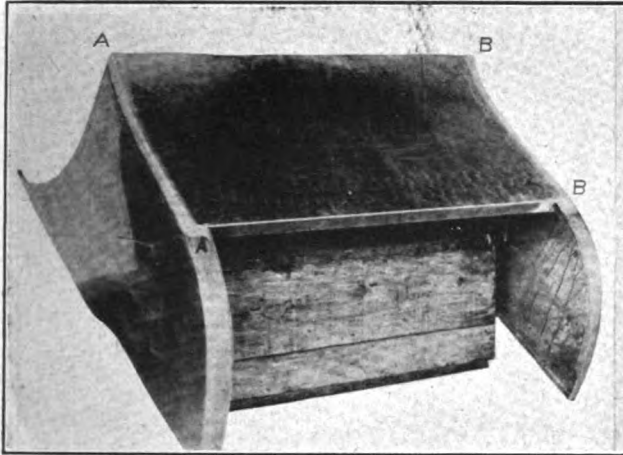

Fig. 6—Rear boot of Franklin roadster welded at A and B in seven minutes

being applied freely. It is necessary to remove all of the remaining flux from the line of the weld and the adjacent metal for the reason that practically all aluminum fluxes contain chlorides, and aluminum is very susceptible to the action of chlorine, either in the free state or in combination with other elements. This causes corrosion, which may or may not appear until after the body has been painted, when it will cause the paint to peel.

Not all fluxes can be used in a wet form, but in the event that a dry flux is used the same precautions in regard to removing all traces of the flux apply. It is customary to have a pail of water handy so that the scrubbing may be done immediately upon the completion of the weld. Care should be exercised not to "trap" the flux in the weld, in which case no amount of scrubbing would remove it. By "trapping in the weld" is meant the flowing together of the metal in the joint above and below the flux so that the flux cannot be entirely burned out.

An advantage in using flux in a moist condition is that when applying the first coat with a piece of cloth both edges of the metal must be rubbed to a distance of about $\frac{3}{8}$ in., which effectually removes any oxide from the surface of the metal and also destroys any greasy material that might form a film over the molten metal. After this

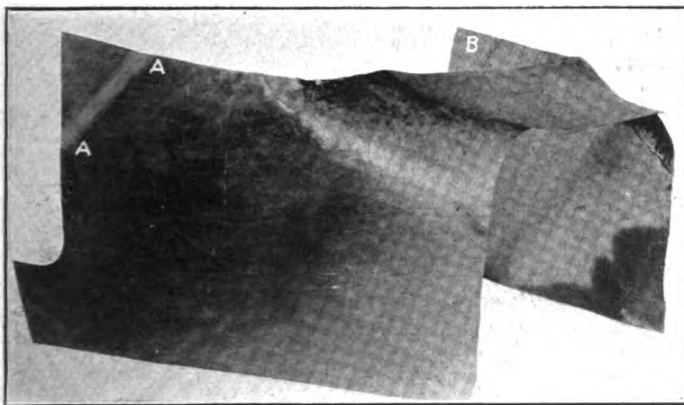

Fig. 8—Small pieces welded to corners of fowl at A and B in five minutes, and effecting considerable saving in material

is done a second coat should be applied sparingly with the stiff brush.

No filling material is used in the welding operation, except at such points as a defect may occur, either through

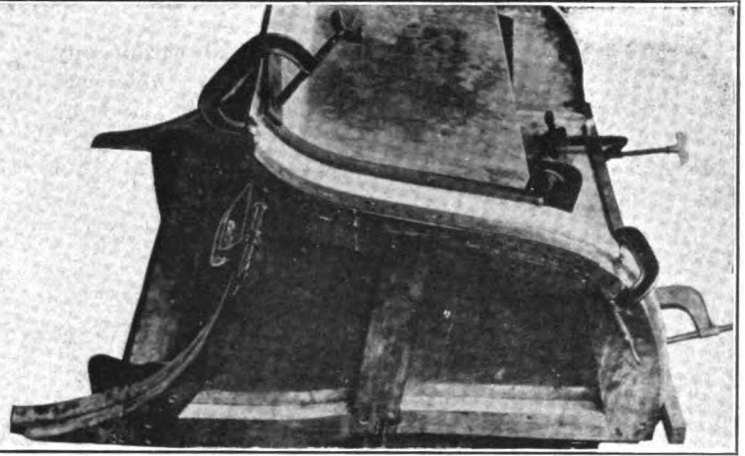

Fig. 7—Aluminum sheets of roadster rear boot clamped in position for welding

the improper handling of the welding flame or lack of a sufficient quantity of flux to allow the metal to flow together freely. In the latter case, usually a narrow strip cut from the same metal is used as a filler, and the opera-

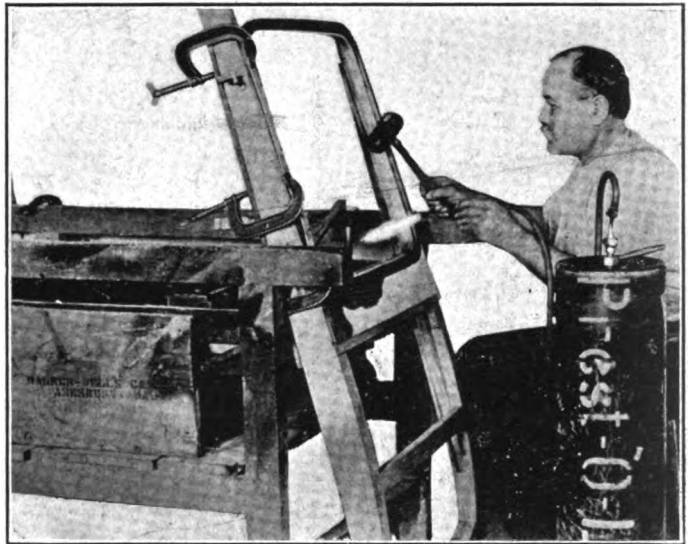

Fig. 9—Annealing aluminum window frame opening with acetylene blow torch to facilitate hammering over frame without cracking

tor re-fluxes the line of weld before starting to fill in the defective spot.

After welding, the line of weld is hammered flat under spring power hammers, similar to those used for flat hammer work in all sheet metal industries.

The Baby welding blowpipe used in this class of welding is a new product of the Prest-O-Lite Co., Inc., Indianapolis, Ind. It is peculiarly adapted to sheet aluminum welding on account of its small size and its easy manipulation. With it a workman can weld thin sheets more rapidly than with the heavier type of blowpipe such as is commonly used in large repair work.

There is only one royal road to prosperity, and that is hard, persevering work, intelligent saving and decent living. Prosperity is the product of a bountiful nature working in combination with faithful labor and a great organization of business, freed from all interference save only that needed to insure publicity and fair competition.—Exchange.

S. A. E. Truck Division Makes Recommendations

Standard controls for trucks which will permit any driver to change from truck to truck without trouble were recommended at a meeting of the S. A. E. truck standards division held at Buffalo, N. Y., August 14. It was considered best not to specify either right or left hand steering wheel location as this does not affect the operation of the truck if all other things are the same. Thus the recommendations are as follows:

Gearshift and hand brake levers always to be at driver's right. The gear lever nearest the driver and the brake lever to the right of the gear lever.

A latch or its equivalent for guarding the reverse slot should be provided for both three and four-speed transmissions.

The position of the lever to give the different gears in a three-speed transmission should be the same as that already recommended for passenger cars.

In a four-speed transmission the highest gear to be in the same position as the highest in the three-speed with the same successive motions for changing down. The low gear will then occupy the place taken by the reverse in the three-speed transmission. No particular position specified for the reverse position on a four-speed layout. The gear lever positions are as shown:

Three Speed	Four Speed
R 2	1 3
1 3	2 4

The gear positions should be clearly indicated on the gate or the base of the gearshift lever.

The hand brake lever should be pulled back to apply the brakes.

Spark and throttle levers should be so mounted that they do not turn with the steering wheel. They should be pushed forward to advance the spark or open the throttle.

The accelerator pedal should be placed to the right of the brake pedal. These recommendations will be put before the full standards committee at the meeting in October. They are based upon practice to some extent and also on what, in the opinion of the division members, is really best for easy manipulation.

Military Requirements Discussed

After the matter of controls had been discussed there was a discussion of the military requirements. It transpired that the Quartermaster's, the Ordnance, Engineering, and Auxiliary departments of the army would be truck users with somewhat different requirements and that other users would be the Signal Corps, the Aviation Corps and the Navy. The truck standards division is working in conjunction with the S. A. E. military transport committee on this matter, and is expecting a request for special work in the near future. At the Buffalo meeting it was suggested that if possible the division should commence discussion of specifications for that size and type of truck likely to be most in demand which would be the one for the Quartermaster's department.

Meetings of most of the divisions are scheduled to be held during the latter part of August and the whole of September. The next general meeting of the whole standards committee will take place on or about October 12. The research division hopes to be able to make further recommendations for testing performance, while the elec-

trical equipment division will have further lamp tests and a number of other matters to report. Important reports from the engine and transmission division and the miscellaneous division are also expected. These divisions have had several matters brewing and a report is expected,

Auto Registrations and Population

	Pop. to Jan. 1, 1916	Cars and Trucks	Pop. Per Car
Iowa	2,220,681	169,558	13
California	2,893,465	187,519	15
Nebraska	2,264,999	80,959	16
Indiana	2,807,480	116,121	17
South Dakota	689,277	37,240	18
Minnesota	2,263,182	122,000	19
Kansas	1,818,383	89,223	20
North Dakota	726,142	33,669	22
Michigan	3,035,148	132,000	23
Montana	452,774	19,580	23
Colorado	948,930	38,000	25
Ohio	5,119,491	208,705	25
Wisconsin	2,486,941	99,000	25
Arizona	251,422	9,743	26
Connecticut	1,234,031	45,731	27
Nevada	104,732	3,900	27
Illinois	6,110,888	203,757	30
New Hampshire	441,545	14,837	30
Vermont	363,075	12,272	30
Wyoming	176,853	5,900	30
Rhode Island	608,540	19,427	31
Maine	770,064	24,027	32
Oregon	822,615	26,110	32
Washington	1,502,632	44,607	34
Florida	882,148	25,000	35
Massachusetts	3,690,748	105,488	35
Delaware	212,489	5,438	39
Idaho	420,291	10,909	39
New Jersey	2,914,928	75,420	39
New York	10,179,971	259,105	39
Utah	429,191	10,729	40
Missouri	3,401,241	83,742	41
Texas	4,386,638	105,000	42
Pennsylvania	8,453,004	189,082	45
Oklahoma	2,158,194	46,000	47
Maryland	1,357,374	26,868	51
New Mexico	403,600	6,226	69
District of Columbia	361,330	5,268	69
Virginia	2,181,516	31,272	70
Tennessee	2,279,691	26,437	86
West Virginia	1,372,756	15,771	87
Georgia	2,836,177	31,259	90
South Carolina	1,116,617	18,000	90
Kentucky	2,372,412	24,725	96
North Carolina	2,386,916	24,460	98
Alabama	2,316,943	19,977	115
Mississippi	1,939,226	16,500	117
Louisiana	1,815,218	13,594	133
Arkansas	1,726,413	12,300	144
Total	101,208,315
Average for U. S.	35.00

Changing Gears

It may be a humiliating fact, but it is nevertheless true, says Scientific American, that the average automobile driver cannot change gears properly. Indeed it is safe to say that a surprising majority do not perform this constantly recurring operation in a way conducive to long life of the mechanism. This may be a reflection on the intelligence and mechanical skill of the public, but the automobile builder should share the blame as he is responsible for perpetuating a mechanism involving so much uncertainty in its operation.

Bronze Alloys for Automobile Work*

Test Bars Not Always a Guide to the Quality of the Casting—Value of the Microscope

By W. M. Corse and G. F. Comstock

Experience in the bronze castings business has demonstrated the need of data on the physical and chemical properties of alloys that are not available in handbooks or other sources of information on the subject. Tables showing such properties determined from actual practice, which may be termed experience tables, are rare; some data exist, but they are usually in the private files of individuals or companies. The Bureau of Standards at Washington reports daily requests for such information and states that there is great difficulty in obtaining data that enables them to make correct replies.

With this need in mind the committee on non-ferrous alloys of the American Society for Testing Materials discussed at a recent meeting the advisability of publishing such data as might be compiled from existing experience tables. On account of the fact that publication of data by that society is made in a formal manner, usually as specifications, it was thought best to delay so as to allow the experience tables to be checked by further work. The need was fully realized, however, and it is with that idea in mind that the table included in this paper was compiled.

Variation Between Bars and Castings

One very important point should be emphasized in connection with the use of the table. Most tests are made on standard test bars either attached to castings or cast separately. Test bars cut from castings where this procedure is possible, show conclusively that a variation exists between results on standard test bars and the metal in the castings themselves.

Castings may show higher or lower results, depending on the design and size of the casting itself. The latter is usually the case on account of the fact that the average size of castings exceeds the test bar size. It has been proved conclusively that the rate of cooling and the shape of the casting affect the results markedly.

Alloys of high shrinkage are much more liable to show internal strains due to practical inability to feed the shrinkage properly, so that the net strength is the difference between the true value for the metal and the internal strains caused by this shrinkage. Manganese bronze, for example, normally shows an average ultimate tensile strength of from 65,000 to 75,000 lbs. per sq. in. It is not uncommon to find this lowered to 30,000 or 40,000 lbs. per sq. in. in actual castings.

Copper-tin alloys, such as phosphor-bronzes, do not exhibit high shrinkage, but show the same proportional discrepancy in strength, on account of large crystal growth and the formation of a coarse network of the high tin eutectoid, which is very hard and brittle. Thurston, for instance, in his standard work on alloys, quotes from

Major Wade's report of 1856 on "Experiments on Metals for Cannon," in regard to gun bronze containing 10 per cent tin, that 83 test bars from gun heads of castings averaged about 30,000 lbs. per sq. in. tensile strength, while 32 small bars averaged about 42,000 lbs. Also, "The average of 12 gun heads was one-half (in strength) of that obtained from small sample bars cast with the guns." The area of the cross-section of the casting, as well as its design, therefore, has a very important bearing on the subject and should always be taken into account in engineering work.

Improper foundry practice affects the tests of any alloy to a very marked extent, so that two metals of the same chemical analysis may show very different results when handled by different foundries. The latter statement is almost self-evident, but many engineers do not realize the effect of small amounts of impurities, some of which are acquired during the melting process, on the final result.

We may learn two things from the above. First, to secure, if possible, the maximum amount of information on castings themselves even at the expense of a few spoiled pieces. Second, to employ the most reliable foundryman you can find, as the best practice is none too good with the appliances existing in the foundry.

Value of Microscope

To the above might be added a suggestion to examine the structure of the metal with the microscope. We all know the value of such a procedure with steel, but so little work has been done with the bronzes that its value here may easily be overlooked. The high copper-aluminum alloys, commonly known as aluminum bronzes, are very interesting from a metallographic standpoint.

In two metals of the same composition but with different structures, due to "self-annealing" or heat treatment in the mold during the casting process, tests show a difference in ultimate tensile strength of 11,000 lbs. per sq. in. and in elongation of 10 to 12 per cent. The microscope was a distinct help in explaining these differences. Our experience in the last two years indicates increasingly the value of metallography as applied to bronzes.

Many engineers believe that when figuring loads it is not safe to go above the value of the true proportional limit as shown by the extensometer readings in the tension test. An interesting point has arisen recently in connection with aluminum bronze. The fatigue test as made with several types of machines indicates clearly that the primitive yield point as shown by the tension test is not the true yield point of the material. The endurance or fatigue resistance of this alloy exceeds that of manganese bronze, or even of steel under certain conditions, although the primitive yield point of manganese bronze is above that of aluminum bronze. It would seem, therefore, that valuable information might be obtained by considering

*From a paper presented at the semi-annual meeting of the Society of Automobile Engineers, June 12 to 16, 1916. Mr. Corse is manager bronze department and Mr. Comstock is metallographist, the Titanium Alloy Mfg. Co., Niagara Falls, N. Y.

In a general way tin and zinc harden bronze and lead softens it. The use of zinc in small proportions is principally for deoxidizing purposes, but has a detrimental effect on the wearing properties. Consequently, when conditions require hard bronze bearings, the tin content must be relatively high. It sometimes goes to 15 per cent in automobile work.

Lead also may go to 30 or even 40 per cent for special work, such as in racing cars, but its effect should be considered in relation to the tin content as well as by itself. It is a good lubricant in bronze. Present practice frequently calls for a combination bearing with a relatively hard back and a soft lining of babbitt metal. The selection of babbitt should be determined by the thickness of the lining, and pure tin or solder can be used if the lining is very thin.

Summary and Conclusions

In order to aid engineers in choosing the right alloy, we must recognize several facts:

Standard test bar results do not necessarily represent

Published data is very meagre, so that any additional reliable information will be a distinct gain to the literature of the subject.

(The paper also contains a large assortment of photomicrographs.)

Body Building in Australia

Body building in Australia is an important industry and is a development of the old carriage trade. The Government has recognized this body-building industry and is protecting the local manufacturers by a heavy import duty. The present duty on a five-passenger body is \$125. Because of the local body-building industry many Australian dealers prefer to buy stripped chassis in the United States and have bodies fitted in Melbourne or Sydney, where the body-building interests are centered. A good five-passenger body costs approximately \$450 in these cities. There is not much economy in having the body built as compared with buying the chassis fitted with the

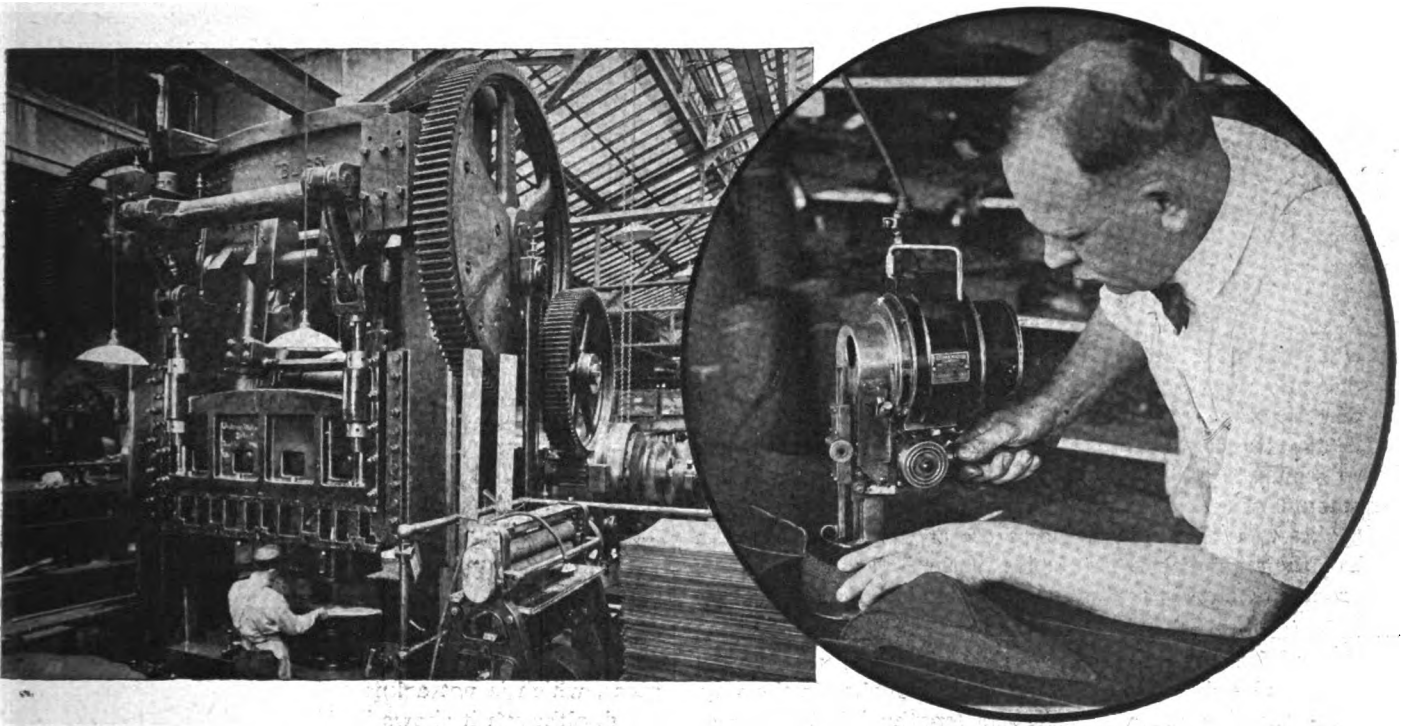

Two machines by which the Chalmers Motor Co. is enabled to maintain its volume of production at the highest mark. At the left is shown the \$90,000 Bliss fender press which, exerting a pressure of 175 tons, presses the metal into a die and forms a fender of surpassing beauty. At the right the electric knife by which Chalmers workmen cut top equipment for 200 cars in a single day

the material in the castings. Wherever possible, secure tests from pieces cut from castings as a check on the properties the metal is shown to possess from test bar results.

The aid of competent foundrymen should be secured in making castings as the chemical analysis or standard test bar results do not tell the whole story.

The microscope is as important in determining the properties of bronze as those of steel. All that is needed is more information on the subject.

The endurance or fatigue test is an important aid in determining the quality of a bronze and like the metallographic test should be used to be appreciated.

The proper composition to use in automobile work depends on the kind of service required. For conditions requiring hardness, high tin is needed. If conformability is more essential, the lead content should be high.

standard factory body. In purchasing chassis without bodies from the American manufacturer approximately fifty per cent of the real cost of the body is generally re-ritted by the manufacturer.

Aland Company Organizing

Organization plans are under way for the Aland Motor Car Co. of Detroit, Mich. The company is to incorporate for \$500,000 and plans to produce, starting in December, a light-weight car fitted with a 4-cylinder 16-valve power plant.

To Make Armored Cars

The Armored Motor Car Co. has been formed at Detroit, Mich., to manufacture armored automobile bodies. The company plans to use King chassis.

Wire, Artillery, or Disc Wheel

The merits and demerits of the various types of wheels in England are treated thus by Light Car, a London publication:

On no part of the car is there such absence of unanimity as in the design of the wheels, and although the choice of any particular type of wheel may be regarded in the light of a fashion or "fad," rather than simply a question of efficiency, each type has its special advantages, which, however, are rarely considered when a car is under consideration by a potential purchaser.

Also it can be said that, while the color of the body and the upholstery, or the combination of both, may form deciding factors in the sale of a car, especially when the prospective buyer is one of the fair sex, the wheels are not considered as being of importance. Probably the type of wheel fitted exerts an influence with the buyer, but he or she may be entirely unconscious of the fact.

Such considerations as these carry their due weight with the buyer who is already a motorist. He is influenced more by mechanical features, and has generally made up his mind beforehand on points which can be altered to suit his particular requirements.

The Wire Wheel

Wire wheels were at one time the most popular type with automobile designers, but apparently for no other reason than fashion they gradually disappeared until very few makers of first class cars fitted them. Then again, without apparent reason, they once more became fashionable. By many they are looked upon as "bicycle" wheels and spell cheapness, although there is little doubt that their cost exceeds that of the artillery wheel. The wire wheel is strong and light in weight; it is also light in appearance, and imparts a light appearance to the car to which it may be fitted. Its chief advantage is the amount of time required to clean it, there being about 40 spokes to each wheel, and as these cross each other, with half their number on the inside of the hub and wheel, the process of cleaning after a muddy day is a tedious one.

It is not only the spokes themselves that need to be cleaned, but the hubs and the rims. The former are most inaccessible, because of the number of spokes in the way, while the rims are a difficult and lengthy job, because of their surface being so broken up by spoke nipples.

The Artillery Wheel

The artillery wheel is a heritage from the horse-drawn carriage, and is the most popular type of the present day. While some wheels of this type have wooden spokes, the majority are now made from two stampings of steel. The wooden wheel has a tendency to rattle and creak when used in hot weather. The artillery wheel is much easier to clean than the wire type, and tends to give the car an appearance of all-round durability. In this connection it is interesting to note that this type of wheel will often go out of truth, and in these days of economical motoring it is well for the car owner to test his wheels, as if they should be out of true tire wear is increased.

This type of wheel cannot, of course, be trued up as can the wire wheel, which is done by merely slackening off a few spokes here and there and tightening others where necessary—a job that can be done by any cycle

wheel builder. The only thing to do with an untrue artillery wheel is to return it to the makers.

The Steel Disc Wheel

The steel disc wheel is rapidly gaining favor with all classes of motorists. Instead of spokes, the wheel is built up from circular plates of steel, between which is clamped the tire rim. Of all types this is the easiest to clean; but, although it gives rather a heavy appearance to a light car, the flat disc wheel is very popular with the sporting type of driver. The disc wheel, made of two plates with the tire rim between, lends itself very naturally to the use of a contractible rim, by means of which the covers can be readily changed or new air tubes fitted. With this type of wheel there is no necessity to carry a complete spare wheel, because when the outer disc is removed the rim with its tire comes away, and a fresh rim and tire may be fitted in its place. This is by no means a small advantage.

The dished disc is usually an adjunct fitted to either wire or artillery wheels primarily to facilitate cleaning, but also with the idea of decreasing the air resistance and thereby economizing engine power. All-steel wheels of the dished type are now being made as an alternative to the flat disc.

There is every probability that in post-war models the disc wheel will be an optional extra with many manufacturers, while with others it may even be fitted as part of the standard specification.

Twisted Crankshafts

Crankshafts that have been twisted in an accident can, of course, be straightened by any competent firm of engineers who have had experience in the work; and provided the journals are afterwards ground up true, the result is frequently as satisfactory as the new article, says a writer in *The Garage*, but not always, for I am certain that however good the balance may be when stationary, it often happens that under the stresses set up while a crankshaft is doing business at high speed—taking powerful blows at one point, and giving hefty thrusts at another, it bends, and tends to resume the shape it was forced into at the time of the accident. This accounts for the mysterious thump one comes across in some engines, which is not a knock in the ordinary sense of the word, although it shows itself when the engine is running fast or pulling hard. When a peculiar thumping is met with in an engine, and the usual remedies have no effect, it is as well to inquire of the owner whether he has ever had to have the crankshaft straightened, because, if so, the chances are that the seat of the trouble is there.

Canadian Ford Co. Earns \$5,000,000

The net earnings of the Ford Motor Co. of Canada, Ltd., Walkerville, Ont., for the current fiscal year of 10 months, ending July 31, show approximately \$5,000,000, which would be equivalent to about \$70 a share on the \$7,000,000 outstanding capital. From these earnings, however, will be deducted the Canadian war tax.

The company has spent \$2,750,000 in erecting four new assembling plants and other extensions to the Ford, Ont., plant, which additions give 162,000 square feet more floor space.

The new Canadian assembling plants are located at Montreal, Toronto, London and Winnipeg.

Condensing the Chassis for Foreign Shipment

With the scarcity of freight steamers and the tremendous demand for space on ocean-going steamers, it behooves the exporter to pack his goods in the smallest possible space, in other words, "condense" the cargo. An example of what is being accomplished along these lines is afforded by the recent truck exports of R. Martens & Co., Inc. By the method employed by this company practically 50 per cent of space and freight rates have been saved. The idea is to condense the motor trucks into the smallest space that will hold all the parts of the truck without a degree of dismantling of the truck that would cost more than the small additional space saved. So important has it been that the company has leased a factory at Stapleton, Staten Island, as a dismantling and packing room.

The saving in freight cost is not the only gain made by this method of packing. When cargo space is scarce, a desired shipment may be made impossible by bulk in excess of the obtainable space; or only part of the shipment may be able to find room in the ships. In the second week of June, this company shipped 24 motor trucks packed small, in hold space that would not have held more than 12 trucks packed in the former fashion; a second shipment of 25 trucks, also packed "condensed," went forward a week after the first shipment; and during the last week in June further shipments aggregating 50 trucks were made—a total of 99 motor trucks in the month. In this condensed packing, the dismantling is of a kind that does not involve much time in the reassembling of the motor parts. It is obvious, of course, that if left to an inexperienced packer the dismantling might be carried to a point where the money saved on freight charges would have to be all paid out for reassembling the truck at its destination.

A Control Without Pedals

A fitting design to enable those who cannot use their legs to drive a car has been patented by Mons. Baudry, who has lost the use of both legs, and whose invention has been awarded a prize by the French Society for the Encouragement of Arts and Industries. The device is easily applicable to existing cars, and, briefly, consists of a coupling from the clutch pedal to a second wheel loosely mounted on the steering column, and well in reach of the steering hand for changing gear, while the foot brake is connected up to the backrest of the driver's seat. This latter idea is merely an adaptation of one of the earliest aeroplane controls, utilizing instinctive movement. This "back brake" is fitted with an adjustable spring to take the ordinary weight of the driver. The least pressure in addition to it brings the brake into action. Gear lever and side brake remain as before, and the patent arrangements claim to be more of the nature of dual control than of a complete conversion from normal.

Applying Truck Tires With a Press

The accompanying illustration shows how one company re-tires truck wheels in a minimum of time, saving expense and loss of time to the firm that needs every truck to maintain its prompt service delivery.

The wheel needing a new tire is placed in a hydraulic press. With steel cylinders acting as buffers, the old tire is pressed off under 100 tons pressure, to be rebuilt or discarded. A steel band for the felloe, if such is needed, is

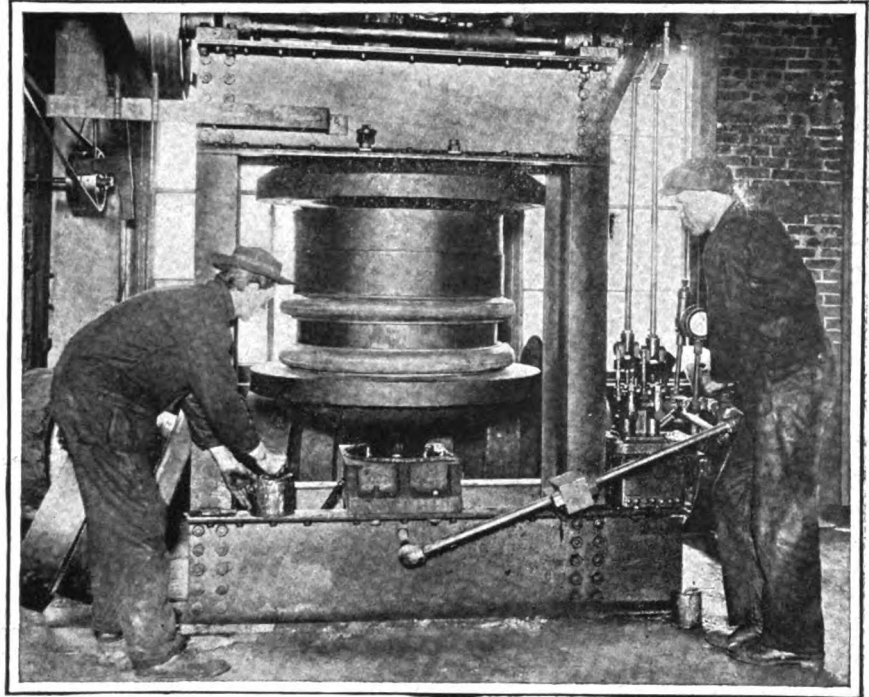

A typical hydraulic press in the act of pressing dual solid tires into position on a motor-truck wheel

taken care of by appliances on hand. A band heater, fed with natural gas, prepares it for the wheel, and cold water quickly shrinks it immovably into place. Replaced on the hydraulic press, the wheel receives its new tire under necessary pressure, steel cylinders again acting as buffers. The entire operation requires but a comparatively short time.

In the accompanying illustration, from a recent issue of the *Scientific American*, is shown how dual solid tires are forced into position on a truck wheel in a few moments' time.

Wolverine Co. Opens Toledo Plant

The Wolverine Auto Co. has opened its new Toledo plant. The factory is located at 2926 Dorr street. It is equipped for the manufacture of about 25 cars a month at the start, and 75 cars a month, beginning early in the fall. By the first of the coming year the company expects to be turning out from 175 to 200 cars a month. It is claimed that the entire output for the coming year has been contracted for by a selling organization. The cars will go on the market at \$1,500 and up. They will be equipped with special type of motors, cord tires and wire wheels. They will be built in several different models.

"Our company is backed by a comfortable amount of capital, and prospects are good, but we will proceed slowly and carefully," said Harry E. King, treasurer of the company.

Carriage Men Establish Oil Cloth Company

The Union Oil Cloth Co. is a new manufacturing industry recently established at Columbus, O., by Victor G. Beebe and Roderick H. Willcox, both well known to the trade as owners of the Peters Buggy Co., of Columbus. This concern they disposed of so that they might devote all their time to the Union Oil Cloth Co. This establishment is equipped with the latest improved machinery, and will cater particularly to the carriage, automobile and furniture industries.

Concerning the new enterprise the Columbus Evening Dispatch, of July 15, says:

"The Union Oil Cloth Co. has, during the past few months, quietly established a large and modern plant at West Goodale street and Michigan avenue, with frontages both on Charles street and West Spruce street.

"This property was formerly owned by the Columbus Gas Co., upon which buildings for the manufacture of artificial gas were located. These buildings have been completely remodeled and largely increased by additions. Space also has been reserved for further construction, as the requirements of a growing business may dictate. The finished production of the plant includes table oil cloth, black enameled drills and duck and a large line of saturated sheetings and other cotton materials.

"The manufacture of these goods requires a considerable variety of special machine equipment and this has been liberally provided and of the latest and most efficient types. The organization of the plant and the choice of its equipment have been carefully studied from the standpoint of first quality production.

"During the entire period of construction the plant has had the advantage of oversight by experts long familiar with the building designs and special arrangements peculiar to oil cloth manufacture. The installment of drying rooms, steam plant, tank storage, mill space, cooking sheds and other features needing special knowledge has been carried out in accordance with the very latest development of the industry. The selection of machinery, all new and perfectly modern, has been by co-operation of department foremen, brought from the best plants in this line, both east and west, and who are now in charge of operation.

"The sales department is effectively organized to cover a wide territory and the available production will undoubtedly need to be materially increased in the near future. The considerable force already employed in operation will be correspondingly increased.

"The quiet and unobtrusive manner in which this valuable addition to Columbus industries has taken its place in the manufacturing life of the city creditably reflects the public spirit of the two men who are sole owners and active managers, Roderick H. Willcox and Victor G. Beebe. For a period of 20 years they have been in constant business association and during the last 12 years have successfully conducted the Peters Buggy Co., of this city, building up a business of large volume and favorable reputation and employing steadily and at excellent wages a large force of employes.

"They are now devoting their entire attention to their new enterprise, the Union Oil Cloth Co., dividing the responsibilities of the management in the same manner which has proven effective and successful in their earlier undertakings. Every detail of organization is under the

personal supervision of one or the other of these proprietors, and the advantage of such closely interested oversight is apparent in the harmony and uniformity of production and product."

An Ingenious Tire Remover

Anyone who has ever removed an automobile tire from a demountable rim will appreciate a simple patented device made for that purpose which will remove a tire in

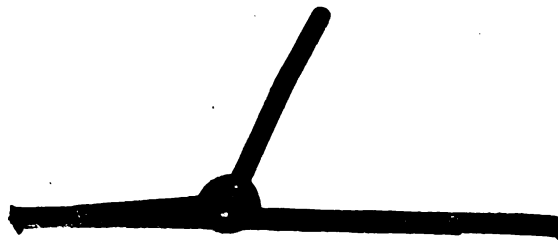

12 seconds and replace it in an equally short time. The device, which is here illustrated, has no clamps or screws to adjust. It holds the rim in a collapsed position while the tire is being removed. When the tire is replaced it

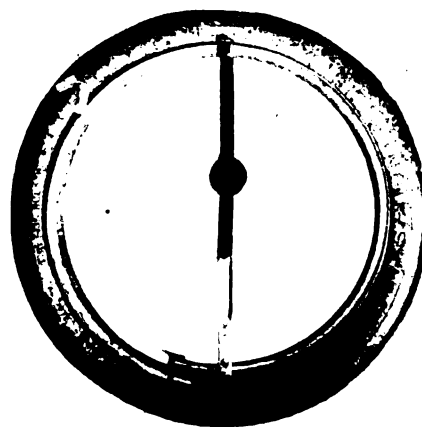

places the rim back to position. The device is shown in the first illustration. The second shows it in position with the rim collapsed, which is done by simply pushing the lever to the position shown. The tire is then removed.

Putting the tire back is just as simple a process. It is

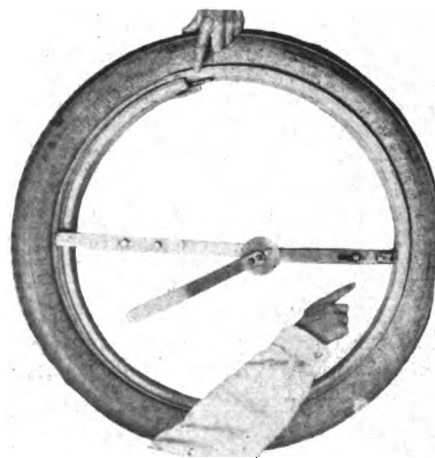

shown in the last illustration where the device is shown pushing the rim back to place.

The Eureka Rim Compressor, Inc., Addison, N. Y., is the concern manufacturing the device, and B. F. Barber, 1487 Union street, Brooklyn, is sales manager.

Cincinnati Hotel Information

Following will be found information, rates, etc., of leading Cincinnati hotels, located conveniently to C. B. N. A. convention headquarters:

The 44th annual convention of the Carriage Builders' National Association will be held at the Hotel Gibson, Cincinnati, O., during the week beginning September 24.

The annual exhibition of parts of carriages, wagons and automobiles, gears, springs, axles and materials used in their construction, will be held in the same place during the convention.

The exhibition dates are from September 25 to 29, and the convention on 26, 27 and 28.

The official headquarters will be at the Hotel Gibson, Fourth and Walnut streets. In the Hotel Gibson will be held the convention, exhibition, reception and banquet; by this arrangement we will have everything conducted under one roof, in rooms suitable for these purposes.

The headquarters hotel, the Hotel Gibson, is a new structure, built and equipped in the finest manner and conducted in the very best style. It also has an ideal room for exhibit purposes.

List of Some of the Cincinnati Hotels

Hotel Gibson, Fourth and Walnut streets. European plan. Three entrances. 500 rooms, 500 baths. Rates: One person, \$2 to \$5; two persons, \$3 to \$6. Have 10 gentlemen club sleeping rooms, with six single beds, large bath, \$2 per person. Suites of rooms, \$7 to \$15 per day.

Hotel Sinton, Fourth and Vine streets. European plan. Three entrances. 400 rooms, 300 baths. Rates: One person, \$1.50, no bath; two persons, \$2.50, no bath; one person, \$2 to \$6, with bath; two persons, \$3.50 to \$8, with bath. Suites of rooms, \$8 to \$16 per day.

Hotel Havlin, Vine and Opera place. European plan. Three entrances. 200 rooms, 180 baths. Rates: One person, \$1.50 to \$2, no bath; two persons, \$2.50 to \$4, no bath; one person, \$2 to \$5, with bath.

Palace Hotel, Sixth and Vine streets. European plan. Two entrances. 200 rooms, 75 baths. Rates: One person, \$1 to \$2, no bath; two persons, \$2 to \$4, no bath; one person, \$1.50 to \$3, with bath; two persons, \$3 to \$6

Hotel Metropole, Sixth and Walnut streets. European plan. Two entrances. Turkish bath and pool. 200 rooms. 60 private baths. Rates: One person, \$1 to \$1.50, no bath; two persons, \$2.50 to \$4, no bath; one person, \$1.50 to \$3, with bath; two persons, \$3 to \$5, with bath.

Grand Hotel, Fourth and Central avenue. European plan. Four entrances. 250 rooms, 75 baths. Rates: One person, \$1 to \$2, no bath; two persons, \$2 to \$3, no bath; one person, \$2 to \$3, with bath; two persons, \$3 to \$6, with bath.

Munro Hotel, 25 to 33 West Seventh street, near Vine. European plan. Turkish baths. Free swimming pool. 200 rooms, 20 private baths. Rates: One person, \$1 to \$2, no bath; two persons, \$2 to \$3.50, no bath; private bath, \$1 to \$2 per room.

Hotel Savoy, Stag, Sixth and Vine streets. European plan. General baths free. 100 rooms, 20 private baths. Rates: One person, \$1 to \$2, no bath; two persons, \$2 to \$3.50, no bath; private bath, \$1.50 extra.

Hotel Lackman, Stag, Vine street, near Fourth. European plan. 60 rooms, 27 baths. Rates: Each person, \$1 to \$2, no bath; \$1.50 to \$2.50, with bath.

It is advised that those desiring rooms at any of the

hotels write direct to the hotel, stating what accommodations are desired, and having the above rates confirmed.

Chute for Automobile Bodies

A labor-saving type of chute is used in the factory of a well known automobile body manufacturer for transferring bodies in a partly finished condition to the floor below, where they are completed ready for shipment. A hole is cut in the floor through which the bodies are slid down a wooden chute covered with steel that is set at an angle of approximately 45 degrees. The chute is slightly curved at the bottom to avoid shock that would otherwise occur when the body strikes that point; and the bottom of the chute is located 30 inches from the floor level so that the bodies will slide onto trucks which are used to move them around during the performance of final operations in the process of manufacture. While on the upper floor of the factory, the bodies are pulled around on a small roller fastened to a block A which falls into the recess provided for that purpose when the body is tilted up ready to slide down the chute. A rope is secured to the rail on the body and the brake that controls the counterbalanced windlass allows the body to slide down easily. When the

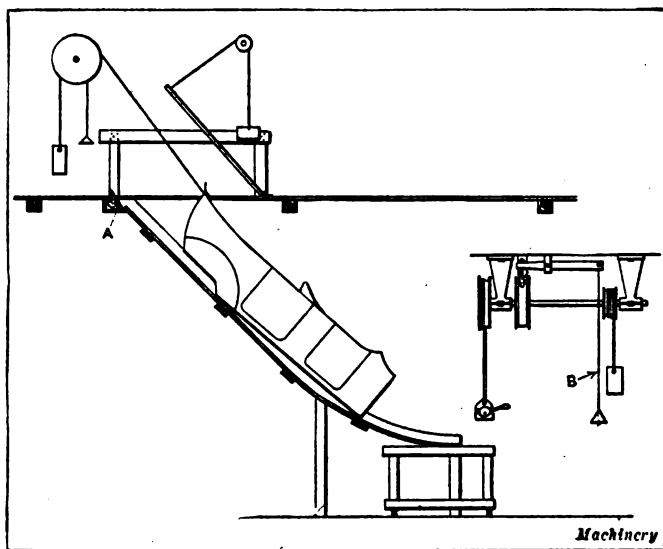

Chute for transferring automobile bodies to lower floor of factory

body has reached the bottom of the chute, a clamp is released and the rope is wound up automatically.

Two ordinary lineshaft hangers are set up with about four feet of shafting between them; fastened on this shafting there are two pulleys, one of which is 18 in. in diameter and one 4½ in. in diameter. The rope that attaches to the body is wound around the large pulley and a counterweight rope is carried on the small pulley. The counterweight weighs just a little less than the body, allowing it to slide down the chute without the speed being accelerated too rapidly; and the action of this counterweight also causes the rope to be automatically wound up after it is released from the work. A brake drum which controls the downward movement of the body can be set to stop it at any desired point; to operate this device, the brake is released by pulling down on rope B, which allows the rope to unwind from the large pulley and drop the automobile body down the chute. When this chute is not in use the trap door is closed and locked; and a hand rail is provided on all sides to prevent anyone slipping through.—Machinery.

Novel Automobile Advertising Uses

The ingenuity shown by users of automobile trucks is interesting and the truck user who is satisfied with merely getting a good looking body on his chassis and seeing that it is kept clean and in good repair is falling considerably short of what he might do.

It is no longer a novelty, says Commercial Car Journal, to see delivering done by motor. The truck is no longer per se a sign of the up-to-date in equipment and methods. Since trucks have become commonplace as trucks, it is up to the users to give them added novelty or attractiveness by making them different in design from the usual run of such things.

A prominent tire manufacturer (Diamond tires) is represented on the road by a truck which is made with a body built to represent a cross section of a non-skid tread tire. The effect is in form not unlike the old prairie wagons, as the top is rounded from the bottom of the body, up over and down to the bottom again. On the side is inscribed an advertisement of the company operating the truck. The tread of the tire is, of course, the top, while the truck bottom takes the place of the rim.

A cigar manufacturer in Dayton, O., not satisfied with a delivery car with his advertisement on it, has mounted on the back of the car a huge cigar bearing the name of the cigar he makes. This cigar is connected in some manner with the exhaust of the motor and whatever smoke is thrown out passes out of the "burning" end of the cigar. Presumably a little extra supply of oil will make the cigar smoke profusely.

A grocer in Marietta, O., who has found it necessary to evolve a unique body for his delivery truck in order to introduce novelty, has painted on the front of the top, so it is easily readable as the car comes toward you, the following, "Here comes Skipton!" As the car passes and you look after it, having noted on the sides that Skipton is the grocer, you read on the rear of the top, "There goes Skipton!"

This is one of the little touches that show that it is not necessary to spend a lot of money or to go into elaborate devices in order to get the credit that goes with originality.

Value of Technical Periodicals

By A. L. HAAS*

There is no man, whatever his position, who does not lose ground unless he reads at least one technical periodical to keep himself informed in regard to new ideas and practice. As a supplement to a restricted field, it possesses a value not to be lightly disregarded.

Access to every text-book printed or to an ideal reference library does not substitute or do away with the necessity for a live technical periodical. The mental effort needed to swallow large treatises is considerable, and it may be said that in most instances they are shelved for reference purposes. If the information contained came in monthly "doses" the effort needed to digest the contents would be considerably lessened. This does not in the least belittle the field an authoritative book serves, but the serial aspect of a technical journal gives it a great advantage as a purveyor of knowledge.

The man who reads a live technical journal regularly is less provincial and has broader views and a wider mental

horizon than one who does not. He supplements his restricted field or specialized task by fuller comprehension. Even casual reading of matter not directly or remotely bearing upon the reader's work stimulates his faculties and helps to broaden the particular corner in which he is confined, making him feel the brotherhood of craft. This indirect benefit is probably even greater than a direct solution of a reader's difficulty. The bond created between a good technical journal and its readers is of a particularly intimate nature, and is dependent upon both paper and reader. It is a mutual service that is rendered, the dependence of the paper upon its readers consisting in the information and help afforded by the passing along of experience.

Increase of Hardwood Stocks

The stock report of the Hardwood Manufacturers' Association of the United States gives a comparative view of the stock of lumber on hand at the plants of members on July 1, and June 1, this year. It is compiled by Secretary W. H. Weller and Chief Clerk H. J. Dollman, and is interesting.

It shows a decrease of 2.4 per cent in plain white oak at eastern mills and an increase of 10.5 per cent at southern mills; quartered white oak, an increase of 6.4 per cent at eastern mills and an increase of 20.2 per cent at southern mills. For plain red oak the increase at eastern mills is 7.2 per cent, and at southern mills 5.6 per cent, while for quartered red the increase at eastern mills is 17.5 per cent and at southern mills 11.9 per cent. Orders on hand July 1, however, are less than on June 1, with the exception of plain and quartered red oak at southern mills.

The report as to poplar shows a decrease of 7 per cent in plain and a decrease of 1.9 per cent in quartered. There was decrease also in the stocks of chestnut of 1.6 per cent. Stocks of cottonwood increased 6.4 per cent, and orders on hand increased from 5,429,000 feet to 7,147,000 feet. Orders for poplar and chestnut were materially less.

Secretary Weller reports much recent improvement in the statistical situation, and manufacturers of both hardwood and yellow pine are more optimistic of the future. If the statistical situation can be kept in hand and the proper relation of supply to demand maintained, he says there should be no trouble in holding the lumber market firm, with every reason to advance prices before long.

Studebaker Additions

The Studebaker Corporation will add 40,000 sq. ft. to the floorspace of the Studebaker Detroit factories. An extra floor, 50 x 300 ft., is to be added to one of the three-story buildings at present used as a warehouse for materials, so that the plants may be better stocked up on materials in advance.

A new one-story building to be used in connection with final assembly work is to be erected on the site purchased by the Studebaker company in May, adjoining plant No. 3 on the west side of Detroit. With the annexing of this property the total floor space occupied by the Studebaker factories has been increased to 150 acres.

Authority to add one-half mile more of railroad siding has also been given, which will be in the nature of double railroad platforms, each one-fourth of a mile long. The value of the construction work that has been authorized will run close to \$100,000.

*London, England.

Proposed Chassis for Quantity Production in England

The July issue of *Automobile Engineering*, of London, Eng., contains a suggestion of what the writer thinks would make the proper car for quantity production in that country, and which he considers could be produced for \$750 for two-seater and \$800 for the four.

As to general dimensions a wheel base of 9 ft. 6 in. and a track of 4 ft. 8 in. has been selected.

"The point to be borne in mind," says the author, whose identity is not disclosed, "is that the notes are intended to convey some impression of the kind of chassis that is required, as it is feared that the average British

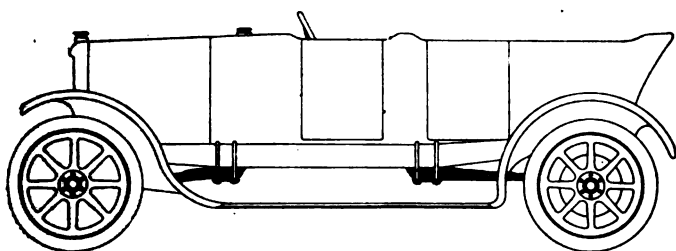

Suggested body lines

manufacturer starting on the production of a quantity car will inevitably end up by producing something of a quality in excess of what is required for the market and purpose for which the chassis is intended.

"The main points that have been borne in mind in the chassis lay-out given are economy in detail manufacturing costs, economy from the point of view of erecting shop costs, and economy of attention when in use. The last-named objective is a most important one, and to carry out this scheme all possible 'attention-requiring' points must be eliminated. No greaser or oil-can hole must occur in the chassis. On this account fixed cantilever springs fore and aft are adopted. These are rigidly clipped to both axles and frame, so that the use of shackles, spring bolts, etc., is avoided, and the suspension thus embodies no moving parts.

"For steering connections the O. S. bearings or bearings of this type are suggested. The O. S. bearings are American productions, and are of a nature that is different from ordinary British practice. The wearing or bearing surfaces consist of compressed graphite impregnated material that needs no attention in use. In this way steering or other likely parts are made self-lubricated, or lubricated statically instead of dynamically.

"The engine, clutch, gear, and steering formed an integrally oiled unit in the original lay-out, but from the viewpoint of production economy it was deemed advisable to separate the steering gear, the advantage of self-lubrication of this unit scarcely warranting the extra complexity involved in the casting. This is a debatable point, and it may still be found advisable to combine the parts in the manner suggested. Both foot and hand brake actuation is by cable—an arrangement that gives at once compensation and freedom from pin joint and other 'attention-needing' spots.

"By reference to the general arrangement of the chassis it will be seen that, for side members, two straight chan-

nel pressings are proposed. They are of good deep section at the center, tapering away at either end, and are set up at the rear to allow for back axle movement. Being without curves or formed dumb-irons, economy is effected in die costs, and also in production prices, as the shaping of the dumb-iron bend on a side member adds considerably to its cost; moreover, even when the channel has been bent and completed, the actual dumb-iron brackets, either castings or stampings, must be provided.

"Four cross members are used, the rear cross member being strongly reinforced by angle plates to insure stability endways. At the front of the chassis the two engine arms, by being made of particular strength, might be employed to serve as a cross member, so that the extreme front cross channel might conceivably be eliminated altogether. This cross member, instead of carrying the starting handle, has a starting handle bracket that is blanked off by a cap fitted in front, as is usual where a starting motor is installed. In the event of the front cross channel being eliminated, an extension of the timing gear cover casting could be arranged to form the starting handle bracket. If this scheme were adopted, it would be as well to carry the engine feet as far forward as possible on the crankcase. The steering box is attached by the engine foot bolt, an arm on the box clamping between the engine arm and the frame block. This enables the steering column angle to be readily set for two or four-seaters. A steering column bracket on the dash insures rigidity.

"The springs—fixed cantilevers front and rear—are bolted direct to the underneath of the channel section by clips circling completely round the side members and springs. The extremities of the springs are, as previously men-

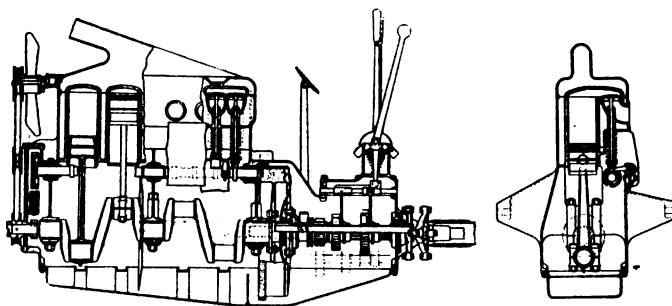

Section through motor suggested as suitable for a low priced car

tioned, clipped rigidly to both axles, half the spring end being turned down and a corresponding turn up on the spring seating being used to form a natural register in both directions to avoid any necessity for doweling or machining of spring seatings in order to obtain location.

"This system of suspension offers many advantages from the viewpoint that has been adopted in this particular lay-out, as not only does it give extremely low cost in manufacture and erection, but it is also in line with the minimum of attention and trouble ideal upon which this, and for that matter most future cars, will be laid out. There being no spring pins, spring bolts, shackles, greasers, etc., the suspension should last indefinitely, provided the springs themselves are wrapped up. While considering this sys-

tem, it is as well not to overlook the fact that it possesses one or two rather obvious advantages. If the system is adopted without tie or radius rods, as shown in the drawings, it will evidently be necessary to have as light an engine as possible. The lateral stability of such a system is poor, and too much mass directly over springs of the type shown is inadvisable, and would inevitably make the front of the car roll. A further point is that, having one coupling point only to the frame, breakage of a spring might prove more disastrous than in the ordinary semi-elliptic lay-out. Much depends upon quality of material and design, and with care such an arrangement should be safe enough; it has been employed on one or two chassis of light build, and is apparently satisfactory.

"The lay-out in these pages is for a $3\frac{1}{8} \times 4\frac{3}{4}$ in. engine, but evidently the general scheme is applicable to an engine of anything about this size; $3\frac{1}{2} \times 4\frac{3}{4}$ in. would probably be better, but it seems, however, that $3\frac{1}{8} \times 4\frac{3}{4}$ in. certainly under present and possible future persecution will be all that any ordinary human being will be able to pay for; moreover, fuel prices and probable shortage even after the war will make small capacity engines essential. The engine body and cylinders are a one-piece aluminum casting with the gear box also. Separate cylinder linings and valve seats will, of course, be necessary with the material

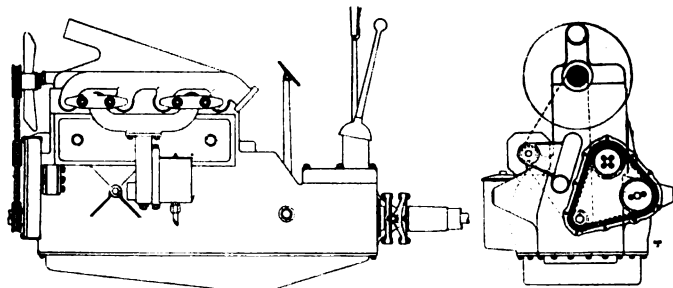

Exterior of unit power plant

proposed, but aluminum gives so many advantages in other ways that it will probably not be found an unpractical arrangement, assuming normal material prices. This proposal, particularly with the large size casting outlined, is admittedly an optimistic one; whether or not we have a firm of founders in this country capable of tackling such a job is an open question. The proposal, however, is not an impossible one, and with a large output would be worth while. In any case, slight modification of the casting—such as the provision of a vertical joint somewhere in the flywheel or clutch region—would make the casting problem much simpler. This arrangement, nevertheless, would add to machining and erecting costs, and on that score would be best avoided.

"Aluminum pistons would be used, the gudgeon pin being probably fixed in the connecting rod and turning in the piston.

"A detachable head with integral water outlet that can also be of aluminum is suggested. A chain-driven camshaft is proposed, the chain extending in triangular form, as seen in the front end view, to drive also the distributor. For chain adjustment the distributor, and its driving wheel, slide in the timing gear case, the joint face on the outside of the casing being covered by the flange in the distributor bearing. Slots in this flanged bearing permit of the necessary sideway movement.

"The water inlet pipe to the cylinders from the bottom of the radiator is incorporated in the main casting, and

will be seen alongside the timing gear in the end view of the engine. On the side of the inlet water pipe the dynamotor driving spindle bracket is shown—also cast on—an arrangement that would probably make more for complexity than simplicity. The better plan would probably be to bolt this on as a separate part. The water pipe butts against the pipe on the bottom of the radiator, a rubber ring being employed, making a joint against the faces or ends of the pipes in place of the usual hose pipe type of connection.

"Obviously the main casting is sufficiently complex as it stands, and for this reason the inlet and exhaust branches are separate, being attached to the cylinder by drops and clamping set-screws.

"With an aluminum cylinder block there is not much option as to the matter of making the exhaust branch separate or otherwise, as aluminum is scarcely suited to be the first receiver of hot and unexpanded exhaust gases.

"With a view to economy, it is suggested that the usual valve pressers and guides be done away with and a rocking lever system of presser be substituted, an adjustable end to the valve being used in place of the usual method of valve adjustment. This arrangement lends itself to economical construction, as all the rocking levers can be threaded on a tube with tube distance pieces, the whole assembly being then clamped against the front of the casting.

"With the general lay-out of gear and clutch shown it is evidently of vital importance to reduce to a minimum the length of the mainshaft. It is quite possible that the length of the unsupported mainshaft in the arrangement shown will produce a noisy box. On the other hand, with a view to economy, it is important to keep the number of bearings to a minimum, and on these accounts a compact narrow clutch is imperative; further, all increase in clutch length and movement means increase of shaft length, so that the reasons for the arrangement shown are fairly evident. It is difficult to arrange an economical design of the ordinary single plate clutch, the actuation for clutches of this type being usually fairly costly.

"The splitting up of the cone surfaces into steps will increase the speed of engagement in direct proportion to the number of steps, a clutch with a large number of steps giving practically instantaneous clutching if arranged with the cone usual angle. On this account the angle of the clutch cone becomes much greater than usual, the angle in the clutch illustrated to transmit the necessary power coming out at about 60 deg. to the horizontal with the leverages adopted, and using a spring requiring reasonably light pressure at the pedal pad for disengagement.

"Three speeds and reverse are suggested for the gearbox, with all sliding wheels arranged on the mainshaft. The selector, or striking lever, gate and selector mechanism, are all in a single casting that forms the gearbox cover.

"With regard to oiling details, considerable economy over the usual systems must be effected, and it is suggested that for the purpose of oil delivery a large pressing or spinning should be attached to the crankshaft center to form an oil thrower. Oil is lifted from the central portion of the sump, and thrown up into the delivery well or collector, seen on the off side of the engine body. This pot or collector forms also the oil filler, and has been arranged so that oil delivered into it is filtered, and feeds the four troughs under the big ends. Oil will inevitably

be delivered by the thrower faster than it can run to the troughs, and a higher level overflow from the collector delivers to the gearbox, whence the oil flows back to the sump over the central dividing web into the crankcase, maintaining a constant level in the gearbox, and circulation to all parts of the system without much expense, complexity, or the use of an oil pump. The usual oil wells would be provided for the camshaft and crankshaft bearings to hold the splashed oil.

"With regard to arrangements at the rear, it is suggested that a torque tube be employed sliding in a T-piece

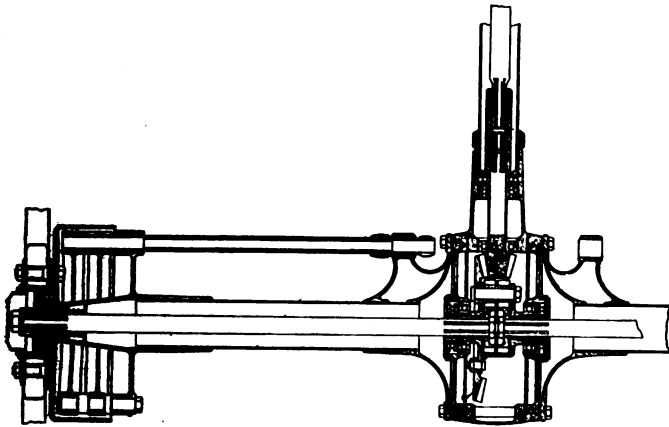

Rear axle with double side by side brakes

of broad base that fulcrums on pins through brackets on the gearbox.

"The rear axle lay-out, as shown, is necessarily very tentative; that is to say, in certain particulars it depends so much on what is obtainable in the way of large-sized pressings. On this account the outer casing construction is extremely difficult to settle. That shown in the drawing is a large diameter tube with castings at each end, the one being the differential box end or cover and the other the axle tube end and spring seating. Both brakes are on the rear wheels, a necessity from the point of view of economy in detail and erection, and wire cable is employed for the actuation of both brakes, as this gives a ready and inexpensive compensation, and eliminates the brake cross-shafts, brackets, etc., etc., with advantages both from the viewpoints of production economy and minimum of lubrication attention in use. Arrangements could be made to conduct a portion of the rear axle lubricant to the brake actuation shafts and fulcrum pins, so that no outside attention was required.

"It was originally intended to include among the published drawings an axle scheme without a differential. In the low-priced chassis the differential does not really justify itself, it having been repeatedly proved that tire wear on an axle without a differential is little, if any, in excess of that which obtains with a rear axle of the usual type. It is suggested that this is due to the fact that with a differential gear scraping of the tires results from wheel spin when one wheel only bumps, a happening that is avoided with a solid axle.

"If the 'differentialless' axle were adopted it would be necessary to arrange a clutching system to enable one wheel to revolve free if required, a small hand lever, similar to the gear change lever, and located in front or at the rear of the brake and hand levers, and actuating a dog clutch, being a likely arrangement. Thus, when the car was moved by hand, as in garage maneuvering, the one

wheel would be released. It could also be freed even in the smaller maneuverings under power, such as backing into awkward corners, etc., etc. The saving in unsprung weight, resulting from an arrangement such as is outlined in the foregoing, is a strongly favorable point, apart from great saving in cost.

"The axle lay-out illustrated is still rather complex, and little in advance of the usual schemes, although a certain economy in fitting and erecting costs has probably been effected by arranging the differential box with separate sides, so that the bevels and differential gear may be erected and adjusted before the axle tubes are bolted up. In any case it seems impossible to effect sufficient economy, if the usual scheme with differential is followed at all, so that the rear axle without differential, or even a substitute, appears to be the correct arrangement in the circumstances. With a dog clutch, as already outlined, a practical working scheme should be evolved."

In commenting editorially on the foregoing article, the *Automobile Engineer* says:

"The recent announcement that the English Ford Co. intend to manufacture their cars complete in this country rather alters the prospects of any concern proposing the production of a low-priced car in England, and, moreover, if the English Ford Co. manufacture large outputs in these islands, it is by no means as necessary to inaugurate the manufacture of another low-priced vehicle here, for, if English capital and labor are employed by the Ford Co., the Imperial result is as satisfactory as if the car were of British design. The only basis upon which the need for the production of another low-priced car can be urged is that the Ford car still leaves considerable room for improvement, and on this account alone the market for a British-made car here and abroad may still

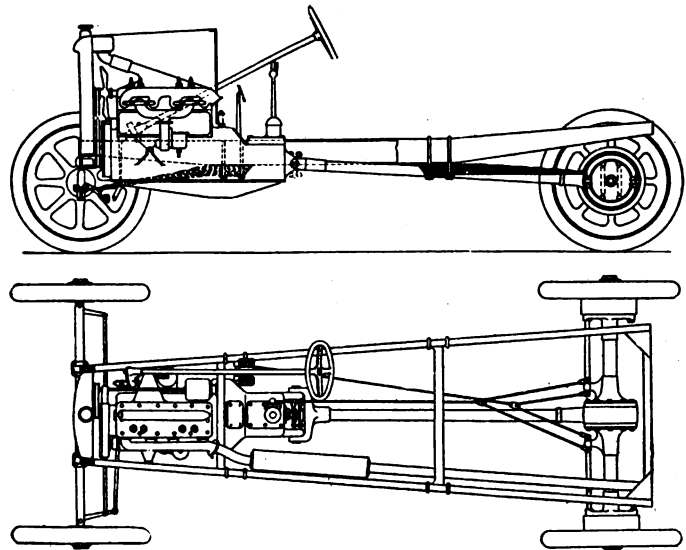

Elevation and plan views of a low priced chassis

make manufacture very well worth consideration.

"With regard to the general construction of the body work, it is suggested that large-sized pressings welded together would probably be the most economical to manufacture. At one time the possibilities of a low-priced body in wood rather commended themselves, but there is little doubt that a sheet steel body is the best. A point not to be overlooked in connection with low-priced body construction is that even the very cheapest of these are still really supplied with an excess of work upon them.

The bodies that are fitted to certain of the low-priced cars evidence this fact. Trimming and upholstery on doors and sides of a really low-priced body are quite unnecessary, as also is too much external finish. An enormous amount of material and labor is wasted in painting, flattening, stoving, and varnishing bodies for even the cheapest of cars, and in this connection we suggest that all that is necessary, from the viewpoint of absolute utility, is a single coat of dead gray paint of unfinished or matt surface, without stoving, rubbing down, or varnishing.

"The light sporting type bodies of pre-war days may be cited as examples. These were upholstered only at the seats, and in very many cases received merely a rough coat of paint, yet such bodies are perfectly comfortable, effective in appearance, and utilitarian. In short, the bodies for the quantity car might be produced in a strikingly economical manner without any loss of efficiency or general appearance in the vehicle."

Distribution of Car and Truck Manufacturers in the United States

States	Automobiles	Commercial Vehicles
California	3	14
Colorado	1	2
Connecticut	3	4
Delaware	1	..
District of Columbia.....	..	1
Georgia	2
Illinois	26	31
Indiana	32	16
Iowa	1	5
Kansas	2	2
Kentucky	3	3
Louisiana	1	..
Maryland	3	3
Massachusetts	7	13
Michigan	49	44
Minnesota	3	21
Missouri	8	14
New Jersey	2	6
New York	23	42
North Carolina	1	1
Ohio	34	40
Oregon	1	1
Pennsylvania	14	32
Rhode Island	1
South Carolina	1	..
Texas	1	2
Virginia	1	..
Washington	1	3
West Virginia	1	..
Wisconsin	7	9
Canada	19	11
Nebraska	1	2
Maine	1
Total	249	326

To Make Exhaust Heater

David Reyam, of Wilmington, Del., has invented a device for using automobile engine exhaust in heating the car. The heat can be applied in various ways, but the principal idea is to heat the entire interior of a closed cars. In cars that are not entirely enclosed, the source of heat is to be at the feet of the occupants, coming up under blankets or such other covering as they may have for protection.

The device does not take the direct heat of the exhaust, but has it passing between coils containing air, which, after being heated, is discharged in the car at the points

desired. It is claimed to be so adjustable that the temperature can be regulated to any heat desired, also that the heat can be quickly generated.

It is the intention, Mr. Reyam says, to manufacture the device in Wilmington. He says it is economical in cost.

Auburn Wagon Co. Loses in Patent Suit

Judge Alston G. Dayton, of the United States Court of the northern district of Virginia, has rendered his decision in the suit of Homer L. Phelps against the Auburn Wagon Co., of Martinsburg, W. Va., which involved the ownership and the right to use certain devices for dump wagons, which Mr. Phelps claimed were his individual property, and in which the wagon company claimed to have a "shop interest."

Judge Dayton's decision vests the ownership of the device in Mr. Phelps and compels the wagon company to pay him a royalty of 50 cents for each device used, except upon the first ten, which the Court ruled that the company was entitled to for experimental purposes.

Mr. Phelps claimed that he invented the device and asked that title be vested in him and that the Auburn Wagon Co. be compelled to pay him a royalty of \$6 upon each device used. The wagon company contended that the device had been patented while Mr. Phelps was employed at the wagon factory, using shop time and shop material during the invention and perfection of the device, and that the agreement between the plaintiff and the defendant company gave the latter a "shop right" in the patent.

Federation Convention

The 17th annual convention of the National Federation of Implement and Vehicle Dealers' Associations will be held in Chicago, October 11, 12 and 13. The Hotel Sherman will be headquarters.

The annual meeting of the Secretaries' Association will be held at the same place on October 10.

During the Federation convention there will be a conference with the members of the committee on dealers' associations and representatives of the sales managers' department of the National Implement and Vehicle Association.

The membership of the Federation has been increased during the past year and a larger number of delegates than usual will attend the convention.

Death of W. N. Beecher

Walter N. Beecher, of 7004 Eggleston avenue, Chicago, died at Onkama, Mich., August 14, where he had been for two months. He was 57 years old. Mr. Beecher was born in Naugatuck, Conn. Since locating in Chicago 33 years ago, he has been associated prominently with the carriage and automobile trade, and at the time of his death was secretary and manager of the Limousine Carriage Mfg. Co. A widow and four children survive.

Pontiac Plant to Expand

The expansion of the Oakland Motor Car Co.'s plant at Pontiac, Mich., will make necessary the employment of 600 more men, according to statements made at the plant. Houses are being moved off property recently acquired on Baldwin avenue to make room for machine shops.

Art and the Light Car

Form and Symmetry in Relation to Construction—Why Certain Cars Fail

Art is divided into two: the fine arts and the lesser or mechanical arts. Painting, sculpture, architecture, music and poetry come under the first heading; the arts of the smith, the carpenter, the potter, the weaver, the printer, etc., under the second. The one contributes to the needs of the mind, the other to those of the body, but both are a necessity to the complete well-being of man, and both are the better able to perform their respective functions by being "beautiful" works of art.

With fine art, as such, the car has no concern. Suitability, or the fitness of things, governs our outlook on life, whether in the abstract or the objective. We do not want Botticelli Madonnas on our door panels any more than Grindling Gibbons carving on plow-share. Fine art is best appreciated in times of ease and recreation, and is far removed from the bustle and grime of the active world.

The Coachbuilder's Art

Coach building has become in modern days a very important mechanical art, and the designer a highly skilled artist. The principle which governs this type of art is that of utility. The characteristics merit, therefore, of a house, a chair, a dish or motor car is to fulfill the purpose for which it is created, and beauty of form in them is nothing else than the instant revelation of this capacity. All decoration that not contribute to this revelation, being meaningless, detracts rather than enhances the beauty of the objects which it is intended to adorn. A car is designed primarily for "use," so that all decoration, as such, is strictly debarred.

However, so complex is man and the workings of his mind that such a theory cannot be applied in its strictest sense with success. A soapbox on wheels is probably just as "useful" as a Rolls-Royce, but it does not satisfy the cravings of the average human being in the same way. Color, the lustre of polished metal, good workmanship, and choiceness of material, being elements of beauty themselves, count just as much in practice as utility does in theory. It is for this reason that the cheap American car finds no admirers, even if it has thousands of enthusiastic "users." Each of these deplors the lack of beauty even while he excuses it, and the majority would be found willing to exchange their cars for one of slightly more attractive design.

Let us now see what constitutes beauty as applied to the car. First of all we must bear in mind that in every art there are certain fundamental laws which must be obeyed. In painting a picture the artist has to represent solid objects and real colors by artificial lines and colors on a flat surface through the application of the rules of perspective and relative tone values. In building a house the architect has to overcome the natural stubbornness of stone, wood, brick and metal, as well as conform to the principles that have through the ages determined the final shape of a dwelling. A car designer in the same way has to contend with the stereotyped box on four wheels, engine in front, gears on the right-hand side, etc., which custom has standardized as the most suitable form for a car to take. The reward of the venturesome is well illustrated by the average Englishman's attitude toward Futurism or the cult of the Simple Life! It is almost as difficult

to persuade people to use a new hygienic toothbrush as to make them see the advantages of central gear levers.

Body Designing—Fundamental Laws

On the other hand, universal practice or popular prejudice serves a good purpose by preventing us running after every new soap bubble, and provides the artist with a safe rule to work upon. An artist is a man who can make the best use of the materials at his disposal within the limitations of his art, and on the whole, therefore, we must be content to leave things where we find them, where custom has determined is their place, knowing that we are working on proved, sound principles which will of themselves fall into disuse so soon as ever their term of service is completed and something better is ready to supersede them. We must, without attempting to alter the existing fundamental laws of car design, endeavor to work within its present limitations to the best of our ability. And in car designing, the artist will find plenty of scope for the exercise of his talent.

Granted that we want to produce a beautiful car, we are next confronted with the perplexing question of "What is beauty, and of what does it consist?" Probably there have been more heads broken on this question than on any other. Ideals of beauty have varied throughout the ages. The ancient Greeks admired most perfection of form in repose, the Romans evidence of muscular ability, the Africans of the dark continent dusky skins, large teeth and a smile that reaches from ear to ear, the Chinese long nails and small feet, and so on down to the present time.

Reduced to a minimum of words, beauty becomes that upon which the eye rests with pleasure. The eye rests with pleasure upon what the mind has been educated to regard as perfection. We have been taught to look at form, symmetry and construction in judging a work of art, and we will now take them in sequence as applied to the car.

Beauty of Natural—Streamline—Form

(1) Form is the appearance or shape of anything. The most beautiful form is admitted to be the simplest that answers the purpose, and it is for this reason as well as the natural laws relating to friction and wind pressure, etc., that all abrupt angles and niches are discouraged on an object that is designed for fast progress through the air—a shell or an aeroplane. Ruskin held a theory that the most beautiful art designs are those which most closely remind the beholder of natural forms; a fluted Greek column being regarded as a beautiful specimen of art because it resembles the tall, straight trunk of a mighty tree. The natural form which is most suited to a car is that of a bird or a fish, and is the line of least resistance, known as "streamline." But this theory must not be advanced too far—it is only an example to bear in mind. It is not sufficient to make a car look like a fish simply because a fish has the most perfect streamline form. A car is not built to form the functions of a fish.

(2) Symmetry is the harmonious fitting of all parts with due regard to size and form. By the application of this principle the whole is made to look as if carved out of one piece of material, an impression which it is the chief aim of the artist to create. Each detail should be in proportion to the others, and nothing that is not a necessity should be allowed to spoil the graceful lines of the completed work. Grace has been called the elimination

of all detail that delays the action of the whole or that attracts the eye away from the main point at issue.

The Governing Principle—Construction

(3) Construction is the third principle of beauty of form and symmetry. It is the manner of executing the artist's design. No matter how beautiful the original plan may have been if the execution is bad. Only by the use of the best materials—not necessarily the most expensive—and of the highest class of workmanship will sound construction be attained and a car converted into a true work of art. Certain well known cars, averaging a thousand pounds apiece, are usually quoted as the most perfect specimens of the coach builder's art. It is not such as these that the light car designers should copy. Cost price is an important question, and we do not want rosewood and mahogany dashboards or silver-plated fittings or silk cushions. What we do want are well built bodies, comfortable, ample springs, doors that shut properly, hoods that close completely, and lamps that can be trusted to keep alight. It ought to be as cheap to produce an artistic, suitable mudguard as an ugly one, and even if the extra hand work costs a little more, light car manufacturers will find that people will be ready to pay 25 per cent or so more if the completed article is a true work of art, i. e., something that is a veritable pleasure to "behold" as well as to "use."

There are a great many little cars which are perfect examples of form, symmetry and construction, but there are many more which fail on one or other of these points. We notice far too many that do not fulfill these requirements. Some are top-heavy, some have too small wheels, some have inartistic lamps. The car we all most admire is the one which shows clean, simple lines, evincing speed and wind-cutting propensities, inviting seats, shining varnish, an alluring color scheme, and unity of the whole.—Viola Meeking, in Light Car and Cyclecar [London].

Ford Cuts Price, Improves Design and Stops Retailing

New prices on Ford cars went into effect August 1. The touring car has been reduced \$80 from \$440 to \$360. The runabout is now \$345 instead of \$390. The chassis sells for \$325; it formerly sold for \$360. The coupelet is \$505 instead of \$590, the town car \$595 instead of \$640, and the sedan \$645, a \$95 reduction from the former price of \$740.

Along with the change of price is a change of appearance. The new Ford cars are fitted with sloping hoods and crowned fenders. The radiator shape has been remodeled to accord with the molded form that has now been adopted.

Present and Former Prices of Ford Cars

	Aug. 1 1916	Aug. 1 1915	Aug. 1 1914	Aug. 1 1913	Aug. 1 1912
Touring	\$360	\$440	\$490	\$550	\$600
Roadster	345	390	440	500	525
Chassis	325	360	Not sold	Not sold	Not sold
Coupelet	505	590	750
Town Car	595	640	690	740	...
Sedan	640	740	975

The Ford Motor Co. will discontinue the selling of cars at retail. The new merchandising scheme is similar to the methods of distributing any manufactured article, in that the actual distribution to the ultimate users will be

through dealers who will have no exclusive territory rights and who will be allowed to sell the machines anywhere or everywhere. The many Ford branches throughout the country are to be nothing more than assembly stations and wholesale distribution points to these dealers. The dealers in turn will be required to maintain regular Ford service and garage methods.

Passing of the Stage Coach

From the intimation of the Lord Chief Justice at Maidstone and of Justice Bray at Gloucester, that they will use a motor car instead of the state coach provided for the judge of assize, may be inferred concerted action which means the passing of these vehicles, gorgeous as a Twelfth-cake ornament, which delight street boys as much as the gilded cars in a circus procession. Certain high personages, it is said, would not complain if the state coach used at the opening of Parliament shared the same fate, for it is alleged to produce a discomfort verging upon *mal de mer*.

Some of these coaches are, however, very beautiful, as well as costly works of art; notably, in addition to the Royal State coaches, that of the Speaker of the House of Commons, which is so heavy that when it is used brewer's dray horses have to be borrowed to draw it. We are all familiar with the State coach of the Lord Mayor of London, and there are some other ancient municipalities, such as Bristol, which have ancient and notable coaches. If they are ever disused they should not be heedlessly destroyed or allowed to fall into ruin, but carefully preserved in the London Museum or some similar collection.—London Globe.

Larger Tires Advocated

Writing in the London Daily Chronicle, Charles Freston says that larger diameters and larger sections are imperatively required for driving in safety and comfort over roads that are full of holes, which are very different things from ordinary ruts. He adds, "A striking confirmation of this contention has just come under my notice. I ran across an old motoring friend who is now an intelligence officer, and we were comparing notes as to past experiences, chiefly on the Continent. He described a journey of his over very bad country in Italy. With a standard tire equipment of 815 mm. by 105 mm. he experienced reiterated trouble in the shape of bursts, and even had his tire torn off the wheels. At length he decided to remove the whole outfit, and had wheels and tires of 975 mm. by 135 mm. fitted in their places. It is a fact that only did he experience no further annoyance, but he ran his car 10,000 miles without even pumping up."

Increased Demand for Automobiles in Bergen

The prosperity now prevailing in Norway is reflected in the increased use of automobiles. A local firm is quoted as stating that the demand for automobiles in Bergen is considerable, not only for pleasure cars but for cars for hire, taxis, and motor trucks. The dealer further states that it is not correct to suppose that America is the only source of supply; there is also an extensive importation from Italy. A consignment of 14 cars from Turin is shortly expected to arrive in Bergen. The United States, however, furnishes most of the cars now imported. The same firm expects in the near future about 50 automobiles from the United States.

Paint Shop

Practical Points for Painters

Miscellaneous Points—Shellac Varnish

By W. G. Scott

Shellac is best preserved in wood, glass or earthenware containers; for, if kept in tin for any length of time, it turns dark brown or black.

Shellac varnish which has become black from such cause may be restored to its original color by bleaching with oxalic acid. One-fourth of an ounce of pulverized oxalic acid, shaken or agitated with one gallon of shellac varnish, will discharge the black color.

Do not use more than this amount of acid, or the varnish will set too quickly, i. e., work "short."

To prevent the discoloration of shellac varnish in tin, dissolve $\frac{1}{4}$ oz. of pulverized borax in 2 fluid ounces of glycerine and add it to a gallon of the shellac varnish.

To prevent the "frilling" or wavy appearance of shellac varnish, often caused by moisture or a change in temperature, mix one-half to one fluid ounce of lavender, oil of cedar or other essential oil with a gallon of the varnish.

If shellac varnish works "short" or sets too quick, as often happens when the gum is cut in wood alcohol, mix a teaspoonful of melted lard with about a gallon of the varnish.

To increase the lustre of shellac varnish, thin 2 to 4 fluid ounces of Venice turpentine, or balsam of fir, with an equal amount of alcohol and add it to a gallon of the varnish.

White shellac, which is made by bleaching the orange shellac with lime hypochlorate, is often found to be difficult soluble in alcohol, due to imperfect washing. To restore the solubility, put the granulated white shellac in boiling water and allow it to melt; then pour off the water and "pull" the shellac the same as molasses candy; then cool the hanks or skeins in cold water.

When dry, pulverize the gum and dissolve in alcohol in the usual way, and you will have no trouble with "seedy" shellac.

Sometimes it will be found that a hot dish or hot water on a shellac-finished table top leaves a white spot. This fault may be corrected by adding 2 to 4 fluid ounces of castor oil to a gallon of the shellac varnish.

To remove such spots from a table top, rub the spot lightly with a piece of cloth moistened with a solution consisting of 3 parts of alcohol and 1 part of castor oil.

To make shellac varnish, or any other spirit varnish pliable or elastic enough for coating paper, leather, cloth, etc., so that the varnish will not crack when the material is rolled or bent, add to 1 gallon of the varnish from 1 to 4 ounces of camphor gum and shake or agitate until the gum dissolves. Two ounces of camphor is usually sufficient, as an excess of the gum renders the shellac exceedingly soft.

To impart to white shellac varnish any desired transparent color, dissolve one-eighth of an ounce of any spirit

soluble aniline color in two fluid ounces of glycerine, then add sufficient of this coloring matter to the shellac varnish.

A waterproof size for cloth, paper, etc., and a medium for mixing dry colors for muslin sign work, may be made as follows:

Dissolve one-fourth pound of soda (crystal, sodium carbonate) in one gallon of hot water; then add one pound of pulverized white shellac and heat to about 200 deg. F., or just under the boiling point, allowing the solution to simmer until the shellac dissolves; then let cool and strain through cheese cloth. This solution may be used for sizing cloth, or dry pigments may be mixed with the liquid to form a waterproof water color.

Sanding, Filling and Puttying

Lead poisoning seldom occurs from the use of white lead ground in oil, but the dust arising from a sandpapered white lead surface is, when taken into the lungs through the nose or mouth, extremely dangerous; therefore, in sanding lead surfaces it is a good plan to dampen the sandpaper slightly with water and use a wet chamois to remove the dust instead of using a dry duster. No. 00 or 0 steel wool may be used in place of sandpaper, if desired, and will be found to work well with water.

In sandpapering natural wood, always sand with the grain, never across the grain; and if an extremely fine finish is desired, use a little dry silica with No. 00 to 0 sandpaper.

Metal work usually requires harsher treatment, and may be cleaned with a wire brush, or by means of a sand-blast; with sandpaper, or by pickling.

The house painter will probably be obliged to use a wire brush and sandpaper, but in the large factories a sand-blast is generally used, and is the most efficient method known.

"Pickling" is only used on "knock-down" material which will go into the pickling tanks.

The usual "pickle" consists of 7 parts of water to 1 part of sulphuric acid, although stronger and weaker solutions are occasionally used for special work. After the "scale" has been removed from the iron or steel, it is rinsed in clean water to remove the acid, and then allowed to dry. When dry, it is washed with benzine, and is then ready to paint.

An improvement on the above consists in passing the metal through a lime-water bath after rinsing off the acid, then allowing the lime to dry on the surface and simply dusting off the powder before painting.

Abrasive materials, like sandpaper, steel wool, and sand, used in the sand blast, answer for removing rough particles from the surface, but do not fill up the uneven spots on metal nor the grain in wood, consequently a filler is used for this purpose.

For metal work, an "iron filler" is generally used, and usually consists of the following pigments: White lead, whitening, keystone filler, Reno's umber and a little pulverized pumice stone, ground in boiled linseed oil and japan. It is a sort of soft putty, and may be applied with a piece

of sole leather or with a wide-bladed filling knife. Occasionally it is thinned with benzine and several coats brushed on in a similar manner to a rough-stuff.

"Rough stuff" is somewhat similar to the iron fillers, but usually contains a little rubbing varnish in order to toughen it enough to withstand the action of pumice stone and water, or pumice and oil.

"Rubbing oil" for use with pumice stone is simply common paraffin oil thinned a little with kerosene or benzine.

Fillers for wood especially the good ones, are simply silex, i. e., floated silica, mixed to a stiff paste, with raw or boiled linseed oil and japan.

For use, the paste is generally thinned with a mixture consisting of equal parts of linseed oil, japan and turpentine or benzine.

It is applied with a brush, crosswise of the grain, allowed to "set," then wiped off, crosswise of the grain, with a cloth or piece of leather.

If the pigment in the mixed wood filler gives trouble by settling hard in the bottom of the bucket, this can be prevented by adding a little "wax solution," made by dissolving 2 ounces of beeswax or ceresin wax in 1 quart of turpentine by means of a water bath. Do not use too much wax solution, or the filler will not harden properly.

Cracks in floors are usually filled with prepared "crack filler," two kinds of which are on the market, one of which is an oil compound consisting of silica, plaster of paris and woodpowder, mixed to a thick paste with oil and japan; the other comes in the form of a dry powder, usually made by intimately mixing 10 parts of silica, 2 parts of plaster of paris, and 1½ parts of dextrine. For use, a sufficient quantity of the dry powder is mixed with water to form a stiff dough.

Cracks in plastered walls are usually filled with plaster of paris made into thick putty with water; but a harder and more tough composition is made by mixing together 12 ounces of white alabastine and 5 ounces of wheat flour. For use, a little of the powder is mixed with sufficient water to form a stiff putty.

Putties for wood and metal have for a base common whiting. Ordinary glazier's putty consisting of whiting, marble dust, linseed oil foots, etc., is a cheap putty and is not suitable for fine work.

House painter's putty of good quality is made by mixing in a chaser from 40 to 50 pounds of dry whiting with 1 gallon of raw linseed oil.

Carriage putty usually contains white lead in addition to whiting, and the painter often adds a little rubbing varnish and japan.

Putties for metals as a rule are quick drying, and in time become as hard as stone. The pigment part of such putties will include whiting, silica and sublimed white lead, while the vehicle part is made up of boiled linseed oil, japan and a small amount of varnish.

The main trouble with putty, either on wood or metal, is that it shrinks in drying under certain conditions and expands on others.

If a little flour paste, paper hanger's paste, be mixed with dry whiting to form a stiff dough, and this dough then worked into any of the regular putties, it will greatly reduce the shrinkage and expansion.

To keep putty from becoming hard, it should be covered with water.

Teaching Negroes Coach Painting

In Hampton, Va., a technical college in existence there attacks the problem of training negroes in skilled callings, an important class dealing with painting. Youths are taught all branches of painting, including sign writing, house, motor and carriage painting. The course covers three years. About one day a week is devoted to learning sign writing.

In the technical shop, students take up sign painting. They begin with the making of simple Egyptian letters by degrees developing skill and doing more difficult work. They learn the principles of good letter formation and spacing. They devote about one day a week for three years to sign painting.

In the carriage shop the student cleans vehicles, sandpapers furniture, leads and prepares surfaces for painting. Next he learns to color and rub varnish. Meanwhile, he receives experience in mixing paints. He is told why certain processes are followed. This same method applies to striping, lettering, varnishing, and finishing work.

A boy receives at Hampton enough training in automobile, wagon and carriage painting during his trade course to earn a living in this one branch of painting. In addition, he is able to do good house painting and interior work. At present, negroes who can do satisfactory wagon and carriage painting can earn, in the south, from \$15 to \$18 a week. It is also true in the south that there is little prejudice against a colored man in the painting trade, if he is a good workman and has a high standard of living. An efficient painter can go into business with a blacksmith, or he can do sign painting, or he can work as a house painter. A good negro or Indian painter, a man with skill and good character, does not find his race an insurmountable barrier.

Trade and academic work are correlated. Students write or speak on topics with which they have become familiar. A partial list is as follows: Care of paint brushes; importance of white lead to painters; how to remove paints from hands and clothing; how whitewash is made; how to measure a room for wallpaper; how to make paste for hanging wallpaper; use of shellac in the home; pleasing color schemes for small houses; why painting pays.

Indiana Reports Big Buggy Sales

Indiana implement dealers are jubilant over the fact that buggy sales are very heavy this year, regardless of reports from the automobile industry to the effect that more machines are being sold than during any one year in the state's history.

It was expected at the beginning of the season that there would be a falling off in the sales of buggies, but as the season progresses, implement dealers are discovering to their pleasure that their predictions were wrong. Many of the branch implement houses in Indianapolis report that their sales of buggies have been unusually heavy.—Implement Age.

Death of Charles E. Kelly

Following an illness of only five hours, due to heart trouble, Charles E. Kelly, aged 62, for 37 years connected with the Columbus (O.) Buggy Co. and for the past three years city sales manager of the Columbus Storage Battery Co., died at 2 o'clock, July 22, at his home, 1071 Wilson avenue, Columbus.

Some Chestnuts of Mechanical Argument Simple Explanations of Three Phenomena Which Are Very Apt to Puzzle the Mind of the Novice

When the first man inadvertently ran away down hill on a log with rough-hewn discs attached, undoubtedly he began certain arguments with his tribe, which arguments one hears still among the motorists of today and will hear until something displaces wheeled traffic for evermore.

These everlasting stumbling blocks are the way weight

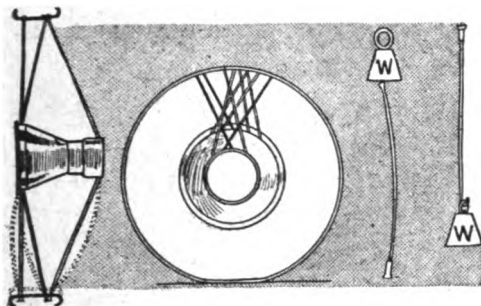

How the weight is carried on a wire wheel. The left-hand sketch shows the lower spoke heads projecting because the rim is being knocked upwards by a bump. The dotted lines show what would happen if the load rested on the lower spokes. On the right is shown the effect of a weight placed on and hung from a spoke

is carried on a wire wheel; which wheel of a car lifts if a corner is taken too fast, and does the top of a wheel move faster than the bottom?

There are still people who refuse to believe that a wire wheel does not carry its load in the same manner as a wood wheel, and, when told that all the weight of the car hangs on the spokes in tension, merely express mild disapproval.

In the hope of persuading some drivers, let us take the diagram representing a section of a wheel with certain points exaggerated. Obviously the car's weight allowed for that wheel rests on the hub, and is considerable. Obviously, also, the wire spokes would bend if that weight

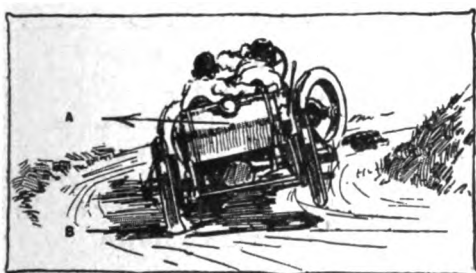

The inside wheels rising when a car takes a corner too fast. The weight acts outwards from the center of gravity, and in the direction of A, while the road resistance to skidding of the car acts at B

were put on top of them, but that weight hanging from the spoke produces no result, since the wire is capable fully of bearing the load in tension. Therefore it is the upper, not the lower, spokes which take the weight, and rags or strings would do it just the same. Now the rim is not made thick purely for amusement or to prevent one fitting the tire by bending the rim edges to suit; it is made thick because it, and it alone, has all the bumping of pot-holes to stand. Look carefully at the diagram. Obviously, the weight of the car rests on the spokes, while any bump on the rim where the latter touches the ground could not be resisted by the lower spokes, as they would

merely double up. It is the rim strength only which withstands the impact.

Now as to the wheel lifting on a corner.

Suppose a car is being driven round in a circle, first slowly, then faster. Its whole weight, acting at its center of gravity, is trying to move outwards because of centrifugal force, which force is the thing that throws any loose object off a revolving disc. Thus there is a force acting in the direction of the arrow A. Now, the only thing which prevents the car moving off bodily is the resistance between road and tire.

Supposing the resistance to be fairly strong, it acts in the direction of the arrow b on all the tire treads.

Now suppose the car goes faster, obviously the centrifugal force becomes greater still acting at A. Take a pencil, stand it upright, hold the bottom to represent the resistance B, and push the top to represent A; the pencil must go over. The car must go over too, and to go over the inner wheel must lift. Anyone wanting to prove it, and not anxious to try it on a real car, had better purchase a clock-work one, set it to run in a small circle, wind it up fully, and let go.

Now for the fact that the top of the wheel moves faster than the bottom. First, one must admit that a driving wheel slipping is not the same thing as a driving wheel going round and traveling forward. The wheel really is a series of levers without any rim, as in the sketch, each

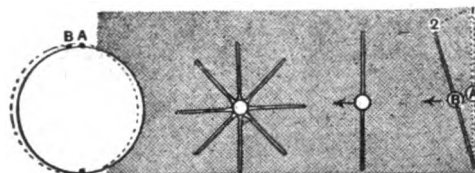

Diagram showing how the top of a wheel moves faster than the bottom. As the marked disc on the left moves forward the upper dot moves from A to B, while the lower one remains over its mark

lever end sticking into the earth, and, as the hub attached to the vehicle is dragged forward, the other end of the lever moves. Obviously the lower end is still in the same spot when the top has gone from 1 to 2 and the hub from A to B. Since the one lever would not do, many must be used—all with the same result—and if a rim is put on it makes no manner of difference, except that the hub does not fall in jerks; the lowest point remains stationary while the highest moves forward.—Light Car [London].

The Use of Sandpaper

"Many persons do not know that there is a right and wrong way to cut a sheet of sandpaper in two," says The Woodworker. "The right way is to fold it evenly, with the sanded part inside, which will prevent cracking or uneven folding. Then cut with a knife, pulling the blade against the sanded paper. For sanding off surfaces, say those which are large and level, it is best to use a block of soft wood, about 2½ in. by 3½ in. To one side of the block glue a piece of rubber belting, or sheet rubber of some sort, and, when the glue has become dry, saw the block into a series of slits, 3/16 in. apart and to within about 1/8 in. of the rubber. The purpose of these slits is to make the block flexible, which will enable it to fit into a concaved or other shaped surface. Still another and similar block may be made solid, for sandpapering large, even surfaces."

Efficiency Pilloried

In psychology the meaning to be given to efficiency is still in dispute. In mechanics it may be described as the ratio of energy that is got out of a machine to the energy put in. Articles, pamphlets and books come to us, in an endless array, all harping on efficiency. As long as they dwell on mute, insensate things we give them respectful attention. When they touch flesh and blood they are largely misleading, and are unworthy of any serious attention. If the average man is well treated he will do his best, and angels can do no more. If he is driven beyond his speed, a revulsion sets in, and he becomes discouraged. Yet we have books telling us how a mechanic should stand at his work, how far his feet should be apart, what particular curve his hammer should describe in descending upon the head of a chisel, with the variable angle inevitable on the recoil of the hammer, and the degree of the muscular tension incident to the succeeding blow. Nature is set aside as if the handiwork of the Creator was a deformity, and some self-appointed inquisitor, incapable of doing any real work himself, sets out to find fault with others that can work.

In our experiences in railroad shops, and elsewhere, we have observed these misguided parasites. He generally comes in the shape of some college fledgling full of theories and self-conceit. Some aged relative pulls a stroke on the board of directors and the young bag of wind is appointed as an efficiency expert. Through his glorified spectacles he sees a gray hair here and there, on the heads of some of the mechanics of whose skill he can know nothing, but they become like spotted leopards in his eyes. They must be replaced. He sees others at the tool room, waiting a minute or two for a certain tool, and the bright idea flashes upon him that boys can do that. Then there two men at the grindstone, one waiting until the other is finished, and the vision of saving three minutes flashes upon him in the shape of improved methods. His chief idea seems to be to keep the noses of the toil-worn mechanics on the grindstone. Accomplishment in final results is beyond him. His methods are microscopic. Like a drill sergeant he must get rid of the individuality of the recruits. His success is not visible to the naked eye, but to sustain his mental attitude he must needs blossom into print, and so the pamphlets come on in unbroken succession.

He should take a rest, and give other people a rest, and then he should be induced to take to some other occupation. There must be some place somewhere, that he could fill, but like the boll-weevil or the mosquito, his good qualities are past finding out. His opportunities are great and his abilities are not to be altogether sneezed at. We might pray that he may take a thought and mend, but we are not praying for miracles.—Railway and Locomotive Engineer.

C. H. A. T. Annual Convention

The twenty-sixth annual convention of the Carriage, Harness and Accessory Traveling Salesmen's Association, of the United States (C. H. A. T.), will be held at Cincinnati, O., September 25, 26 and 27.

The annual meeting will be held Monday evening, September 25, at the Sinton Hotel.

The annual dinner will be held Wednesday, September 27, at the Hotel Gibson, in the Fountain Room.

There will be speeches, cabaret and dancing—things to delight the gleeful souls of the C. H. A. T. membership.

The business meeting will be one of unusual interest and all members are requested to attend. The meeting will be called by President Rennekamp at 8 o'clock Monday night, at the Hotel Sinton. Everybody is invited to attend this meeting.

The entertainment committee is preparing to give the members a surprise at the dinner on Wednesday night. The banquet will be in the nature of an old-fashioned chicken dinner, after which the banquet hall will be cleared and dancing will follow until 12 o'clock.

M. T. C. A. to Hold Outing

The Motor Truck Club of America announces the date of their annual outing as September 13, to be held at Karatsonyi's Hotel, Glenwood Landing, Long Island, N. Y. The personnel of the outing committee is as follows: Roderick Stephens, ex-officio, Olin J. Stephens, Inc.; Willard S. Mears, chairman, Sterling Motor Truck Co.; T. A. Aspell, B. F. Goodrich Co.; A. C. Bergmann, The Perfection Spring Co.; Charles G. Bond, Coulter & Bond; F. Nelson Carle, General Vehicle Co.; Haywood P. Cavarly, National Lead Co.; C. M. Geiger, Peter Doelger Brewing Co.; Robert Hunt, Jr., Peter Doelger Brewing Co.; Joseph Husson, Commercial Vehicle; Henry K. Jaburg, Jaburg Bros.; George H. Logan, Empire Carrying Corp.; Joseph K. Orr, Thos. Orr Trucking Co.; W. Oscar Shadbolt, Shadbolt Mfg. Co.; C. Monroe Smith, Commercial Car Journal; A. G. Taylor, E. W. Bliss Co.

Phases of Patent Law

The slightest changes which effect a new and useful improvement in a device are patentable. One asserting prior use of a device as precluding patentable invention must prove such use beyond reasonable doubt. Neither of two men who jointly constructed a machine is entitled to secure a valid patent therefor as the sole inventor. It is not contributory infringement of a patent for one to furnish repair parts to buyer of a patented machine, unless the repairs amount to a reconstruction of the machine, or unless the machine was sold under a contract limiting the right of repair. The buyer of such a machine is entitled to make necessary repairs and replace worn-out parts, not separately patented, so long as the identity of the licensed machine is not destroyed.

Franklin 400 Pounds Lighter

The Franklin Company shows a 400-pound reduction in weight in its series 9 car just announced. It is pointed out that the increase in gasoline economy is almost in proportion to the weight saved. The weight of this latest car is 15 per cent less than last year's.

The Franklin Company uses aluminum in body, mudguards, engine base, transmission case—in all 150 parts of this material. Electric furnace nickel steel is used in transmission gears, electric furnace chrome-silico-manganese steel in springs and axle shafts; 3½ per cent nickel steel in universal joints and axle tubes. In a great many instances a given amount of metal has been redistributed and a stronger part produced, or a less amount of metal used and a part equally strong produced.

Wheel Holder for Tire Manipulation

A particularly useful device has been designed by S. Peyton Barnes, Manchester, Eng., for the purpose of facilitating tire manipulation on a wheel detached from the car. Motorists who have had occasion to endeavor to fit a new air tube or cover to their spare wheel have probably, without exception, found that tire changing has been rendered even more troublesome than it is naturally by reason of the difficulty of holding the wheel firm while the tire is removed or refitted. Mr. Barnes's device is intended to overcome this difficulty by providing a firm support for the wheel in the most convenient position for tire manipulation.

The device consists of a block of hard wood secured to the bench by means of a long bolt passing through both and extending considerably above the block, a beveled steel washer being used between the bolt head and the bench. The hard wood block is held to the bench by a nut screwing down into a recess in its center, and is so shaped as to its bottom surface that its top surface lies at an angle of about 13 degrees from the horizontal.

When it is desired to manipulate a tire, the detachable wheel is dropped over the bolt extension, and on to the

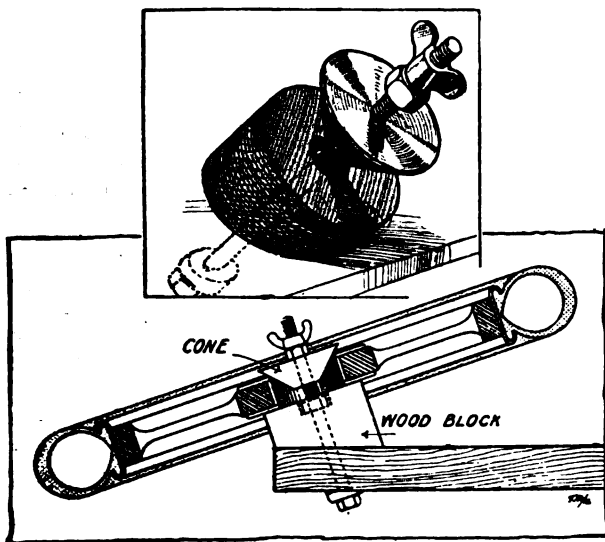

latter is then placed a steel cone which centralizes the wheel when a nut and winged lock nut are screwed down the bolt on to the cone. The latter is tightened into the hub center, but, owing to the cone providing only a line contact with the edge of the hub center, it is possible to turn the wheel quite easily as various parts of the tire are dealt with.

It has been suggested that as good a position for such a wheel-holding device would be on a wall, from which it might project so as to hold the wheel practically vertical, but Mr. Barnes states that he has made a number of experiments in this connection, and has found that the best position of any for the purpose is the one that he has adopted. He goes so far as to maintain that the exact angle at which the wheel lies when it is clamped down is very important indeed, a slight difference one way or the other making a great deal of difference in the ease or otherwise with which the tire can be handled.

The Kelly-Springfield Motor Truck Co., Springfield, O., has made an additional shipment of 33 large trucks to the War Department for use on the Mexican border.

Timken Buys Out David Brown

The Timken-David Brown Co., Detroit, Mich., the majority of the stock in which was originally owned by the Timken-Detroit Axle Co., has been bought out entirely by the Timken-Detroit company, and the manufacturing operations will be consolidated under the management of the axle company.

That portion of the Timken-David Brown stock which previously was not held by the Timken Axle Co. was owned by David Brown & Sons, Huddersfield, England, and the new move divorces the two entirely. The Timken-David Brown Co. has always been regarded as a part of the Timken factories in Detroit, being under the same roof. It manufactures worm gearing for motor trucks and power transmissions, and the gear generating machinery was brought over originally from Huddersfield.

Cornelius T. Myers, formerly chief engineer, and later manager in charge of engineering, manufacturing and sales of the Timken-David Brown Co., has severed his connection with the concern, disposing of his interests to the Timken-Detroit Axle Co. Mr. Myers, it is announced, will again take up consulting engineering in Detroit, making a specialty of motor truck, tractor and worm gearing applications to all kinds of power transmitting machinery. Myers has had an active engineering experience, having been mechanical engineer for the General Motors Co., and chief engineer of the General Motors Truck Co.

Lewis Perfects Spring Machine

Fred H. Lewis, president of the Lewis Spring & Axle Co., Chelsea, Mich., has designed and perfected a machine for the purpose of forming and hardening automobile springs, and this concern is now manufacturing the machine for the market. It is claimed that this equipment not only constructs springs rapidly and with a great saving of labor, but that it also effects an increase in the strength of the spring.

The machine employs the revolving head principle; the spring leaves are heated and then placed in the forming holder, after which the head revolves and plunges the spring into a tempering bath. At the same time the other head is brought to the top of the receiver ready to have another spring leaf put in position. The machine will turn out leaves at the rate of 1,800 per day. The steel is drawn to shape and hardened without the necessity of hammering, and this is said to be the means of preserving the original fiber structure of the metal.

Trimming a Bucket Seat

A good way to trim a seat of this description is to first form a roll of wadding around the top of the seat. To do this in the quickest way tack a piece of muslin or burlap all around top edge, make a roll of heavy wadding, fold in the burlap which you have tacked around seat, draw tight and tack fast. This method forms a good edge for the top of seat. Then tack a piece of burlap about four inches up from seat board, having the burlap wide enough for stuffing and tacking on top of seat, when the burlap is tacked all around at bottom. Pick enough hair or moss for stuffing the back. Stuff under burlap solid and tack burlap along top of seat back, being sure that stuffing is smooth and solid; fill out the corners evenly, so as to form a nice round corner.—Automobile and Carriage Builders' Journal.

Prime Mover Designed on a New Principle

Readers who are students of design will be interested in a very original engine named the Lewis made in England in which cranks and oscillating connecting rods with their attendant bearings are conspicuous by their absence. The engine can have two cylinders or four, but the number must be even, as the pistons are built up in pairs, rigidly connected by double rods, between which revolve rollers A, B, C, D, on hardened pins. The rollers engage with an eccentric cam which is not truly circular, but so shaped that both rollers will always be in contact with it

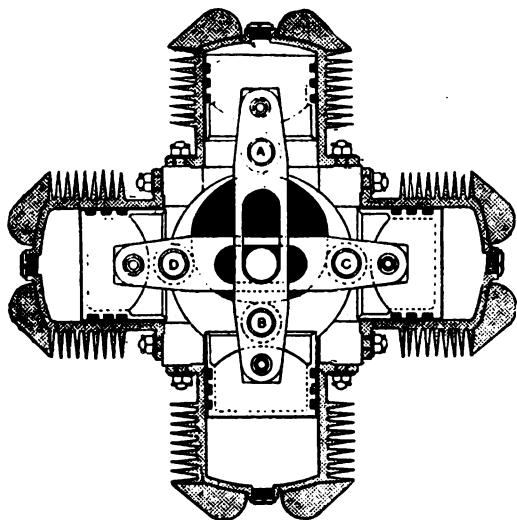

Section of the Lewis engine, showing how the pistons are joined in pairs

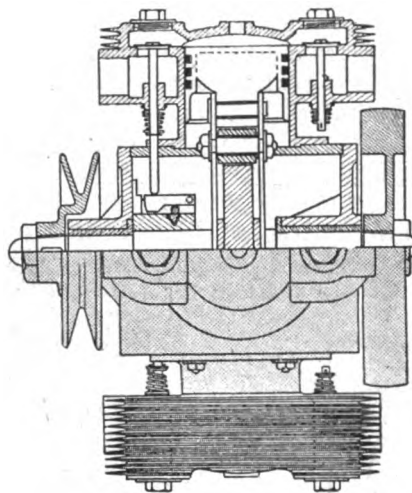

The Lewis engine shown partly in section. The inlet valves in this particular engine are set to work automatically

as it revolves. The main shaft passes through slots in the connecting rods, and the thrust of the drive is carried by the short solid part of the rod between the connection to the piston and the roller.

The tappet rockers are operated by a scroll on the engine shaft, which is designed to bring forward a peg carried on a small sliding guide once in every two revolutions of the engine.

The engines built on this principle had a short stroke, and turned over at a very high speed, giving the advantage of considerable power combined with small size. In fact, in Mr. Lewis's workshop a twin engine, the length of which was less than two feet, was capable of exerting 20 horsepower.

Scripps-Booth Corporation Organized in New York

The Scripps-Booth Corporation has been organized under the laws of the state of New York, with a capitalization of 70,000 shares, no par value, of which 25,000 shares are to be offered for public subscription at \$50 per share. The Scripps-Booth Corporation is a consolidation of the Scripps-Booth Co., Detroit, and the Sterling Motor Co., also of Detroit. The corporation will have no bonds or preferred stock and no floating debt.

Plant extensions are planned which will permit an output of 12,000 cars for 1917. The Sterling company has made the engines for Scripps-Booth cars since they were first built and now becomes a unit of the organization. The Scripps-Booth capital was increased from \$100,000 to \$350,000 early in the year following the entrance into the

concern of Clarence H. Booth, who will head the new corporation.

Milburn Adds Bending Plant to Its Factory

To handle its increasing trade, especially in the electric vehicle department, the Milburn Wagon Co., Toledo, O., has leased the plant formerly occupied by the Toledo Bending Co., at 1104 Summit street.

The Milburn company is transferring its business wagon department to the new branch. It will use its new quarters for the building of standard and custom-made bodies.

New mechanical equipment is being installed in the new branch. The plant will be under the supervision of Emil J. Seeman who, for 40 years, has been connected with the Milburn.

"Our plant was getting too small and we didn't have sufficient room to enable us to fill the orders as fast as they came in—that is why we are starting a branch factory," said H. W. Suydam, president of the Milburn company.

"We have repeated orders for custom-made auto bodies, but we had to decline them because they would interfere with our routine business, which has kept our men going the limit. In the new quarters we will be able to take care of that business."

Personal Mention

S. H. Humphrey, formerly vice-president of the Chalmers Motor Car Co., has been elected vice-president and manufacturing manager of the Briscoe Motor Corporation, Jackson, Mich.

R. C. Caples has resigned as general traffic manager of the Western Maryland Railway to become associated in a confidential position with John N. Willys, president of the Willys-Overland Co., Toledo, O.

B. C. Swinehart, for the past three years manager of the Philadelphia branch of the Republic Rubber Co., has been recalled to the main factory of the Republic company at Youngstown, where he will take charge of the solid tire sales. H. D. Worthington, assistant manager of the Philadelphia branch, succeeds Mr. Swinehart as manager.

William Sparks, president of the Sparks-Withington Co., Jackson, Mich., has secured Assistant Manager Baker, of the Harrison Mfg. Co., as superintendent of the radiator department. This new branch of the business is now in such a shape that it is expected that by October about 300 radiators will be produced daily.

It is stated that in some places in England motorbus companies are compelled to fit their vehicles with a hooter that automatically gives warning when a speed of 12 miles an hour is exceeded.

C. H. A. T. Passes Resolutions on W. W. Wood

The board of directors of the Carriage, Harness and Accessory Travelers' Association in session at New York City on Wednesday, August 9, 1916, in appreciation of the life and work of William Wallace Wood, who died on July 24, passed the following resolution:

On July 24, 1916, William Wallace Wood, formerly president of the Carriage, Harness and Accessory Travelers' Association, and its most valuable member, passed away at his home in Camden, N. J., and was laid to rest on July 27, 1916.

At the regular convention of the C. H. A. T. in October, 1895, William Wallace Wood was elected to the office of president, and his administration of the office justified



the membership in that he ably served every interest of every member, was at all times keenly alert to the needs of the travelers in the lines represented, and by his able administration brought our association to a more firm place in the trades that we aim to serve.

It was not, however, his service while occupying the highest office in the gift of the association that endeared our departed brother to every member, but his active services from the very start of the organization until the very moment of his death, were always directed toward the uplift of the industry through the medium of our work. It was but a few days before his passing that our officers were advised by him that on account of his illness he would have to forego the pleasure of serving this year in the preparation of our annual report, a service rendered us these many years, and these reports remain with us as silent testimony to the fact that he was indeed our leading member, and his viewpoint was the one that members followed in the making of better conditions in the trades we represent.

We mourn his loss.

We deem this occasion as fitting to call attention to some of the things for which our brother worked. He believed at all times that men engaged in the same line of business should affiliate with each other to the end that from common council the best results would come to all. He believed that the C. H. A. T. was designed to help and benefit all men in the industries that are covered by our membership. He was always ready to do the work of the association, and in this he has left us a valuable heritage, for only by work and loyalty can be accomplished what we aim to do.

Brother Wood had the ability not only to think but to

place his thoughts in words, and we have all sat at his feet to learn great things. His writings and his speeches teem with the great thought that God is the father, and that all men are brothers.

Gone from our councils. Gone from our association. Gone but never to be forgotten so long as the banner of the C. H. A. T. remains in the trades of carriage, wagon, harness and automobile building.

His life's work is closed. His services are ended. We urge our members to keep alive his memory in their hearts, and by their acts follow the precepts and examples of our brother who has gone on the long journey from which no traveler ever returns.

JESSE L. NELSON,
Secretary-Treasurer.

Shortage in Aluminum Goods Industry

A somewhat disturbing factor in the aluminum goods industry is the serious shortage of raw and semi-finished materials, which has already forced a small interest to close shop temporarily to await new stocks. The construction of new garages and shop additions to existing buildings continues at a rapid rate and in large volume. A feature of the demand from these sources is the heavy and more expensive equipment desired, compared with the requirements for these purposes in past years. In the smaller cities, at least, the garages have taken the place of the commercial machine shops, or the shops are made to form the nucleus of garage businesses, so that more elaborate and extensive equipment is required for the dual purposes.

American Vanadium Co. Sold for \$7,000,000

The American Vanadium Co., Pittsburgh, Pa., which owns 92 per cent of the known deposits of vanadium and which sells very largely to the makers of high-speed tools and automobiles, has been taken over by eastern capitalists for \$7,000,000. J. L. Replogle; Kuhn, Loeb & Co.; Harrison Williams, and others, are at the head of the syndicate.

Mr. Replogle, now vice-president and general manager of the company, will be made president after the conclusion of the sale. J. J. Flannery, head of the present company, will become chairman of the board.

National Motor Vehicle Extensions

The National Motor Vehicle Co., Indianapolis, recently purchased half a city block east of the present factory and has broken ground for two additional buildings. The main building will be 60 x 380 feet in dimensions and three stories high. It will be of reinforced concrete and steel of the same general design of the National buildings built a year ago. The second building will be one story high, 140 feet wide and 328 feet long. It has been figured out that the new buildings will add more than 114,000 sq. ft. of floor space to the plant. The contract calls for the completion of the new additions by November 9.

Technical School Opens October 2

The day and evening classes of the Technical School for Carriage Draftsmen and Mechanics, conducted under the auspices of the Carriage Builders' National Association and the National Automobile Chamber of Commerce will open for the season on October 2, under Instructor Andrew F. Johnson, in the Mechanics' Institute, 20 W. Forty-fourth street, New York City. The correspondence department is open the year round.

The Little Shop in the Back Yard

Some months ago we wrote you about "Bill and His Little Shop," and perhaps you would like to hear the rest of the story. Bill has gone. The shop got too small to hold him and his work. It fairly pushed off one side of the building until he had to do all his pipe work out in the yard, and even then the shop was too small and he had to run nights to get the work done.

This was the way he happened to get out: A member of a large concern came around one day and saw what Bill was doing. He got interested in Bill and his work, and now Bill has a shop nearly 200 feet long, and we had the pleasure of selling him a good power plant for it. (We got our money, too.) We were up to see him a few days ago. He has a nice office in one end of his shop with a little drafting room attached, and while he has a typewriter, Mrs. Bill doesn't run it any more.

Bill (by the way, we must not call him Bill any more) is now a manufacturer in every sense of the word, but when we look over our back fence at the little shop now tenantless, we feel both glad and sorry—glad for Bill because he has branched out and done so well, and sorry because the little shop that used to hum with activity and business, now, like the harp that hung on Tara's walls, is "silent, drear, and dead." Perhaps the environment has something to do with Billy's success in getting ahead. From our back window you can look and see no less than six of these little shops. They don't blow any whistle, although every one has an engine lathe and some of them a complete equipment. They start in about 7 o'clock (p. m., mind you), and their lights are never turned out when we "turn in." The one nearest to us is building an automatic transmission for an automobile. That is, as you go up a grade, the car automatically drops into third speed, and if the grade is still too great for the power of the engine, it drops into second, and then into first if necessary. He has been working on it two years now, and while to us it seems perfect, you know it is hard for a mother to give up her baby, and so he is still at it. The next firm up the back fence is doing die work, and has expert mechanics of the highest ability, but many a time they have made me a set of tools (and they were good ones, too) for half what I could get them made for elsewhere. There is something funny about it. A man puts up a kick when you ask him to work overtime for less than time and a half, but he will go cheerfully into his own shop and work on a job that doesn't pay him more than half his regular day rate.

Bless the little shops in the back yard. They may keep us awake nights, but they are turning out a product which can be produced in no other way, and that is mechanics who handle the business end as well as the mechanical details, and make a success of both.—A. P. Press, in Machinery.

Anchor Buggy Co. Making Ford Tops

The Anchor Buggy Co., Cincinnati, O., is making tops for Ford cars which are designed to be quickly attached or detached, so that a closed car may be had for cold weather use and an open car for warm weather. The frame is of wood and the sides and back are glass. The doors of the top and car doors open together, being operated by a single patented locking device. The interior of the top is upholstered and the windows can be lowered

or may be removed and curtains substituted. The price of the sedan car is \$57.50, and the coupe \$47.50.

Overland First to Occupy Wendell Building

The Willys-Overland Co., which recently took control of its sales in New York City by the establishment of temporary quarters at Columbus Circle, has leased the property at Broadway and 50th street, belonging to the Wendell estate. This building has remained vacant for 14 years. The Overland company will be the first tenant and will occupy the entire three floors and basement. The company has also opened a used car department at 1700 Broadway, near 54th street.

Capt. Lewis Pays Creditors in Full

Creditors of the L. P. C. Motor Co., Racine, Wis., which failed a year ago with liabilities of \$102,000, were paid in full on August 17. The assignee, F. Lee Norton, settled up the bankrupt estate by the payment of 23 per cent of the money owed, and Capt. William M. Lewis sent his personal check for the balance. The Lewis family recently disposed of its interests in the Mitchell-Lewis Motor Co. for \$5,000,000.

Brown Purchases Peters Buggy Co.

The Brown Carriage Co., Cincinnati, has purchased the entire stock and good will of the Peters Buggy Co., Columbus, O., and the stock has been shipped to Cincinnati. The Brown Company expects to continue to build the Peters line in Cincinnati, and will supply the Peters buggy with the Peters name plate, maintaining the quality of that well known vehicle.

Armored Cars for U. S. Warships

Armored automobiles cradled on the decks of warships, in seagoing rafts, for the use of detachments of the United States marine corps in shore operations, may soon be added to the regular equipment of naval vessels. Experiments at the Boston navy yard have demonstrated that these cars can be stowed aboard by the means of electric cranes on war vessels in a few minutes and take up small deck space.

Toledo Bending Co. Quits Business

The Toledo Bending Co., Toledo, O., has discontinued business, the stock and raw material having been purchased by the Pioneer Pole and Shaft Co., Piqua, O.; St. Marys Wheel and Spoke Co., St. Marys, O.; and The J. M. Skinner Bending Co., Toledo, O.

Emerson Co. to Build \$250,000 Plant

The Emerson Motors Co., of New York, will build a \$250,000 automobile plant at Orton street and Borden avenue, Long Island City. The plant will be the first of ten units, the entire group to cost \$2,500,000 and to have a daily output of 1,000 cars.

The future of commercial relations between Russia and the United States is very promising. In some quarters it is held that Russia is the greatest single field in the world for new business.

Trade News From Near and Far

Doings of Motor Truck Builders

The Warren Motor Car Co. is the name chosen by the L. L. Crosby Co., Bangor, Me., which will build a light power delivery wagon.

Klieber & Co., builders of Klieber trucks, are building a factory at 11th and Folsom streets, San Francisco, Cal., which will have 50,000 sq. ft. of floor space and cost \$100,000.

The plant of the Ohio Tractor Mfg. Co., Marion, O., has been purchased by W. H. Houghton and associates of Marion. It will be used for the manufacture of commercial vehicles.

The Elmira Commercial Car Co., Owego, N. Y., has been formed for the purpose of manufacturing a 1,000 lb. delivery car, listing at \$425. The cars will be ready for delivery about January 1 next.

The Chase Motor Truck Co., Syracuse, N. Y., will shortly announce Model X, a three-ton, worm-drive job to retail at \$2,800, equipped with cab. This new model will round out a line of trucks of $\frac{3}{4}$, 1, $1\frac{1}{2}$, 3 and $3\frac{1}{2}$ ton capacities.

The Standard Motor Truck Co., Detroit, will take possession of its new three-story concrete building on Bellevue avenue, September 1. The building will cover 60,000 sq. ft. of floor space and will be equipped with modern machinery.

The Adams Truck, Foundry & Machine Co., of Findlay, O., which two years ago changed its name from the Adams Bros. Co., has discontinued the manufacture of Adams commercial vehicles, to concentrate on foundry and machine shop work.

The Robinson Machine Co., Ecorse, Mich., has purchased a piece of ground west of Mill street, where a factory will be erected to manufacture its new Truckford, for converting a Ford car into a one-ton truck. Fifty men will be employed.

The Hub Motor Truck of Columbus, O., manufacturing a gasoline-electric commercial vehicle, has now started to manufacture its first truck, which will have a capacity of $2\frac{1}{2}$ tons. This will be completed by fall, and tested for experimental purposes.

The capital of the Hurlburt Motor Truck Co., of New York, has been increased from \$150,000 to \$450,000. The company's business in 1915 showed an increase of 500 per cent and the orders now on the books are greater than the entire business of 1915.

The Corliss Motor Truck Co., organized recently at Corliss, Wis., with \$100,000 capital, has reequipped part of the former plant of the Wisconsin Engine Co., and is now producing a light delivery truck, selling for \$650 and \$695, depending upon the body style. Harry Mohr, formerly of Chicago, is in charge.

The Moreland Motor Truck Co., Los Angeles, Cal., has announced a new model, a light delivery truck, the chassis to sell at \$990. This new model is a 1,500 lb. capacity

rapid service utility truck equipped with Wisconsin motor, Timken axles and roller bearings, three-speed transmission, and with solid or pneumatic tires optional.

The Atterbury Motor Truck Co., Buffalo, N. Y., despite its recent fire, which caused a damage of \$100,000, is continuing to do business. About three-quarters of the plant is still in working condition and orders can be filled within a week's time. The most of the loss is covered by insurance. The structure will be rebuilt as soon as the insurance adjusters finish their work.

The Ford one-ton worm-drive truck is expected to be ready for delivery this fall. Demonstrators are expected to be in the hands of Ford distributors or agents within the next few months. What the price will be at which the Ford Motor Co. will sell this truck, officials claim not to know. It was stated from other sources that the price will be around \$500, possibly a bit lower than this, and that it is expected that 200,000 of these trucks will be made during the first year.

A special meeting of the stockholders of the Cadillac (Mich.) Auto Truck Co., manufacturers of the Acme truck, has been called to consider increasing the capital stock of the company which now is \$100,000. It is understood the company intends increasing production about 500 per cent next year and will build a plant with additional capital. More trucks have been manufactured and sold during the first seven months of the company's existence than had been estimated for the first year of business.

The Republic Motor Truck Co., Alma, Mich., will erect two new factory buildings just east of the old plant and will extend from Michigan avenue along Bridge street to the river. The main structure is to be 60 x 1,000 ft., and one story high. Parallel to the large building will be built a stock room 36 x 500 ft. The two buildings will have a floor space of 48,000 sq. ft. and will cost about \$38,000. The company at present employs 700 men in the old factory, and this number will be practically tripled upon completion of the new buildings.

The United States Motor Truck Co., Covington, Ky., at its recent annual meeting, voted to increase the capital stock from \$300,000 to \$1,000,000, divided into preferred and common. The preferred is cumulative 7 per cent, but participates in earnings with the common up to 10 per cent. The directors declared the regular annual dividend of 7 per cent on the preferred, and place quite a large sum to the credit of surplus from the excess earnings of the company. R. C. Stewart, president of the company since 1914, has ably directed and developed the business to its present prosperous condition.

The Metropolitan Motors, recently incorporated in Delaware with a capital stock of \$1,000,000, has purchased business and plant of the White Star Motor & Engineering Co., 55 Liberty street, New York, manufacturer of motor trucks, which operates a plant at 759 Third avenue, Brooklyn. The new company will produce a one-ton truck in quantity, which will undoubtedly necessitate greatly

increased manufacturing space and equipment as the plant has been running at capacity, producing two, three and five-ton units. William C. Mack, one of the founders of the Mack Brothers Motor Car Co., is president, and Charles W. Paget is secretary.

Body Building Briefs

The Excelsior Seat Co., Columbus, O., has made an addition to its factory that will be used for the manufacture of motor ambulance bodies.

The Monroe Body Co., Pontiac, Mich., is to build a new office structure and a plant for pressed steel work. The capital of the company has been increased to \$150,000.

The Edward G. Budd Mfg. Co., Philadelphia, Pa., is having a factory addition built at Twenty-fifth street and Hunting Park avenue for the making of automobile bodies.

The Union City Body Works, Union City, Ind., has awarded the contract for the erection of a new factory building which will allow it to double the capacity of its plant.

The Eastern Top & Body Co., Philadelphia, has been incorporated with a capital stock of \$10,000, by William J. Beury, 3432 North 17th street; A. L. Hastings, 5024 North 15th street, and Charles E. Buery, 2104 West Tioga street, to manufacture tops and bodies for vehicles.

A further enlargement of the plant of the Auto Body Co., Lansing, Mich., will occupy a large tract of land purchased adjacent to the factory, where a three-story factory extension will be built. It will front 75 feet on Turner street and run back 200 feet west of Turner. The company has also made an arrangement with the New York Central railroad for the installation of a direct freight siding with that railroad from its plant.

The Fisher Body Co., the Fisher Closed Body Co., both of Detroit, and the Fisher Body Co. of Canada, Ltd., Walkerville, Ont., have been consolidated in a new organization under the name of the Fisher Body Corp., with a capitalization of \$5,000,000 in 7 per cent cumulative \$100 par preferred stock and 200,000 shares of no par value. The company furnishes bodies to Ford, Buick, Cadillac, Maxwell, Chalmers, Hudson and others, and its business for the current year is estimated at \$20,000,000. Last year it amounted to \$10,000,000.

The Detroit (Mich.) Weatherproof Body Co. has been reorganized and has taken over the business of the C. R. Wilson Body Co. The company's capital stock is now \$750,000, instead of \$10,000 when it was first incorporated. The concern manufactures the Detroit top, which is a detachable, convertible, all-year-round limousine top of medium price. The company has secured factory space totaling about 50,000 sq. ft. at 1884 Mount Elliott avenue and will employ several hundred men. A new factory will be erected. It is planned to make from 50,000 to 100,000 tops. The officers of the company are: S. P. Douglass, president; Lawrence Moore, vice-president and general manager; H. H. Sanger, treasurer, and H. B. Barbour, secretary.

General News of the Vehicle Industry

The Salisbury Wheel & Mfg. Co., Jamestown, N. Y., has increased its capital from \$500,000 to \$1,000,000.

The Michigan Wagon & Mfg. Co., St. Johns, Mich., has sold its plant to the Hayes Motor Truck Wheel Co.

The Bour-Davis Motor Car Co., Detroit, Mich., has completed a concrete and steel factory, 150 x 200 ft., four stories.

The Cleveland Cadillac Co., Cleveland, O., will shortly begin the erection of a brick building to be used as a service station.

The Thermoid Rubber Co., Trenton, N. J., has under way construction work designed to double the present capacity of the plant.

The Daniels Motor Car Co., Reading, Pa., manufacturer of the Daniels eight, has increased its capital stock from \$100,000 to \$250,000.

The Ford Motor Co., Cleveland, will erect a four-story concrete and steel service station, 100 x 145 ft., at Detroit avenue and West 65th street.

The Chevrolet Motor Co., Flint, Mich., has purchased the plant of the Wagner Mfg. Co., Toledo, O., and will use it to manufacture transmissions and gears.

Delivery of wire wheels from the new factory of the Hayes Wheel Co., Jackson, Mich., will start in September, the new plant having just been brought to completion.

The Motor Hearse Co., Detroit, Mich., has been incorporated with a capitalization of \$100,000 by Sidney B. Winn, 930 Brush street, Patrick J. Power and August J. Bloom.

It is announced that George W. Dunnyham, Evansville, Ind., formerly with the Chalmers Motor Co., is organizing a company with \$2,000,000 capital stock, to manufacture automobiles at that place.

The Kelsey Wheel Co., Memphis, Tenn., A. E. Mahannah, general manager, will add to its plant and equip to manufacture automobile wheels complete with hubs and steel tires. Addition to the power plant will also be made.

It is currently reported that the Sayers & Scoville Co., Cincinnati, vehicle manufacturer, has taken a lease on a building at Bank and Patterson streets. Its former plant on Colerain avenue was destroyed by fire several months ago.

The Timken Roller Bearing Co., Canton, O., has taken out permits for a two-story office building, 105 x 206 ft.; a grinding department, one-story, 100 x 105 ft.; a one-story hardening room, 50 x 100 ft., and a packing room, 43 x 80 ft.

Announcement of plans for the erection of a four-story office building at the plant of the Buick Motor Co., at Flint, Mich., has been made by Walter P. Chrysler. The building, which will be reinforced concrete structure, will cost \$250,000.

The Canadian Briscoe Co. has taken over the plant of the Brockville Electric Light Co. at Brockville, Ont., and will convert it into a plant for the manufacture of steel parts for automobiles. The Canadian Briscoe Co. is a subsidiary of the Carriage Factories, Ltd., of Brockville.

The Stoughton (Wis.) Wagon Co. has filed an amendment to its articles of incorporation in the office of the secretary of state, increasing its capital stock from \$250,000 to \$500,000. The company makes farm wagons and farm machinery. F. J. Vea is president and William C. Hegelmeyer secretary.

The capitalization of the Haynes Automobile Co., Kokomo, Ind., has been increased from \$1,200,000 to \$4,000,000, half of which is in common stock and half in 7 per

Split Leather

a substitute for and always inferior to

KERATOL

Any
Finish



The Home of Keratol

All
Grains

Nothing but hair grain leather wears better than KERATOL!

Samples and prices upon request

THE KERATOL CO.
SOUTH AND VAN BUREN STS., NEWARK, N. J.

cent preferred. Proceeds of the sale of the preferred stock will be used for the erection of extensive additions to the company's factory.

Western Spring & Axle Co. Improvements

Substantial additions are now being made at three plants of the Western Spring & Axle Co. At the Hess Spring & Axle Co. plant, Cincinnati, O. a large new building will, when finished, enable this company to increase its output of automobile axles and keep pace with a steadily increasing demand. The erection of this building will also make possible an increase in spring making facilities. At the J. B. Armstrong Mfg. Co., Flint, Mich., a new building will be used for heat treating and fitting departments, and at the Cleveland-Canton Spring Co.'s plant, Canton, O., a large addition will be used for stock room and finishing department.

WANTS

Help and situation wanted advertisements, 1 cent a word; all other advertisements in this department, 5 cents a word; initials and figures count as words. Minimum price, 30 cents for each advertisement.

PATENTS

Patents—H. W. T. Jenner, patent attorney and mechanical expert, 606 F St., Washington, D. C. Established 1883. I make a free examination and report if a patent can be had and exactly what it will cost. Send for circular.

Index To Advertisers

Acme Die Casting Corporation.....	1
Acme Rubber Mfg. Co.....	4th cover
Bliss, E. W., Co.....	1
Brawley, T. R.....	2d cover
Carter, Geo. R., The, Co.....	36
Columbus Bolt Works Co.....	4th cover
Doehler Die-Casting Co.....	4th cover
Dowler, Chas. L.....	36
DuPont Fabrikoid Co.....	4th cover
Eccles, Richard, Co.....	36
Fairfield Rubber Co.....	36
Hartford Clock Co, Inc., The.....	1st cover
International Rubber Co.....	36
Keratol Co., The.....	35
Landers Bros. Co.....	36
Mulholland Co., The.....	36
Murcott-Duden Co., Inc.....	2
O'Bannon Corporation.....	3d cover
Payne Co., E. Scott.....	36
Porter, H. K.....	36
Sheldon Axle and Spring Co.....	2d cover
Shortsville Wheel Co.....	2
Standard Oil Cloth Co., Inc.....	3
Technical School for Carriage Draftsmen and Mechanics	3d cover
West Tire Setter Co.....	36
White-Quehl Mfg. Co.....	36
Wilcox, D., Mfg. Co., The.....	4th cover
Willey Co., C. A.....	2
Williams, J. H., & Co.....	4

BUSY BUYERS BRIEFS

CHARLES L. DOWLER
 CARRIAGE AND WAGON HARDWARE
 108 North Third St., Philadelphia, Pa.
CUSHION MANUFACTURER
 Pure Stearic Acid Candles. Wheel Stock. Snow
 Flake Axle Grease.

Buckram, Webbing,
 Mohair, Bow Lining and Strain Straps,
COLORS TO MATCH
 Burlap, Transparent Celluloid, Sheetings
 and Cushion Canvas.
 We Guarantee prompt shipments, best goods, lowest prices.
Landers Bros. Co., Toledo, Ohio

**MULHOLLAND
 BUGGY SPRING**
 Reduces weight of springs one-half.
 Made in one size only but will fit bodies
 of all widths.
 Write for further particulars and prices.
THE MULHOLLAND CO. DUNKIRK, N. Y.

White's Brazing Sleeves
 For applying Rubber Tires
 Send for Samples.
WHITE-QUEHL MFG. CO.
 431 E. Pearl St.
 CINCINNATI, OHIO

E. SCOTT PAYNE CO.
 Carriage and Automobile
HARDWARE
 Horse - Shoers' Supplies
 362-364 North Gay St., Baltimore, Md.

Automobile and Carriage Leathers,
Leather Welts and Gimps
 All Kinds of Leather Specialties
 WRITE US FOR PRICES
THE GEO. R. CARTER CO.
 CONNERSVILLE, IND.

Results Always Follow
 Advertising in
THE HUB

It Pays
 Others
 It Should
 Pay You

PORTER'S BOLT CLIPPERS
 "Easy" "New Easy" Allen-Randall



To Cut 5-16, 3-8, 1-2, 5-8, 3-4 Inch.
H. K. PORTER, EVERETT, MASS.

CARRIAGE—WAGON—AUTOMOBILE
 AND SPECIAL
DROP FORGINGS
 QUALITY—THE
 BEST
Richard Eccles Co., Auburn, N. Y.
 PROMPT
 SERVICE.
 WRITE FOR CATALOG.
 SEND BLUE-PRINTS OR MODELS
 FOR OUR QUOTATIONS—IT WILL PAY YOU

THE FAIRFIELD RUBBER COMPANY

Manufacturers of

Carriage Cloth, Imitation Leather,
 Automobile Cloths, etc.

FAIRFIELD, CONNECTICUT

The WEST Hydraulic Tire Setter
WILL CUT DOWN EXPENSE



Tires set cold in
 one minute. This
 machine saves
 time—does the
 work better and
 quicker, does
 a way with
 burned streaks.
 Only necessary
 to measure one
 wheel in a lot.
 Does not char
 the rim, and

thus make the tire loosen prematurely. Saves resandpapering
 of wheels. This machine is now increasing the profits of many
 manufacturers. Send for catalog and read about it.

WEST TIRE SETTER CO., ROCHESTER, NEW YORK

"INTERNATIONAL" RUBBER CARRIAGE CLOTH

The Rubber Carriage Cloth of **SERVICE** and **QUALITY**
INTERNATIONAL RUBBER CO.

Write for Samples and Prices
225 Fifth Avenue, New York

O'BANNON
ARTIFICIAL
LEATHER

Reg. U. S. Pat. Off.

Moleskin "Quality"

The Best Leather Substitute

All the
Standard Leather Grains, Colors and Finishes

GUARANTEED

Against Cracking, Peeling or Wearing Down
to the Cloth Backing

WRITE FOR SAMPLES

O'BANNON CORPORATION

200 Fifth Avenue, New York City

Carriage Mechanics

Desiring to improve their present
Condition should attend the

TECHNICAL SCHOOL

FOR

Carriage Draftsmen and Mechanics

SUPPORTED BY THE

Carriage Builders' National Ass'n

The object of the School is to teach men to design vehicles and make working drawings, and to otherwise facilitate their work in the shop. Only those men employed in carriage or automobile building or their accessory trades are admitted to its privileges.

The classes are conducted in three divisions, viz.: Corresponding, Day, and Evening. The former is open during the entire year, while the day and evening classes are in session only from October 1 to April 1.

The tuition is moderate.

For prospectus and full particulars, write to the instructor,

ANDREW F. JOHNSON,

20 West Forty-fourth St.,
NEW YORK CITY

C. B. N. A. OFFICIAL CONVENTION NOTICE

Office of the Secretary and Treasurer, Mount Vernon, N. Y., September 2, 1916

The Carriage Builders' National Association extends to the Carriage, Wagon and Sleigh builders of the United States a cordial invitation to attend the Forty-fourth Annual Convention of their Association at Cincinnati, O., September 25 to 29 of this year.

A visit to the Convention and Exhibition of the materials used in the construction of your products and in your business, and a few days spent in the hospitable and interesting city of Cincinnati cannot help being of benefit to you in every way.

The Association will be happy to see you and you will be welcome whether a member or not. The Convention and Exhibition are free to every Vehicle Builder, as our sole purpose is to benefit all builders of Vehicles.

By direction of the Association,

HENRY C. McLEAR, Secretary.

WILCOX

FINE
FINISHED
FORGED

CARRIAGE HARDWARE AND GEAR IRONS

Write for Prices and Catalog

The D. Wilcox Mfg. Co.
MECHANICSBURG, PA.

Acme

means

Highest Quality

in

Rubber Carriage Cloths

Acme Rubber Mfg. Co., Trenton, N. J.

DOEHLER DIE-CASTINGS

are the stand-
ard of com-
parison in the
ever growing
die-casting
field. The
superiority of



Aluminum Die-Cast
Magneto Housing

"Doehler" quality and the unfailing reli-
ability of "Doehler" service have attained
for them this enviable position.

DOEHLER DIE-CASTING Co.
BROOKLYN. N.Y.
NEWARK. N.J. TOLEDO. OHIO.

DU PONT FABRIKOID

REG. U. S. PAT. OFF.

MOTOR QUALITY

FOR carriage upholstery is the standard material
used by large manufacturers. It ranks next to
expensive grain leather in appearance and dura-
bility. Guaranteed superior to coated splits or
so-called "genuine leather." Adopt Motor Quality
to save time and money.

DuPONT FABRIKOID CO.

WILMINGTON, DEL.

TORONTO, ONT.



SEND
FOR
SAMPLES
TODAY

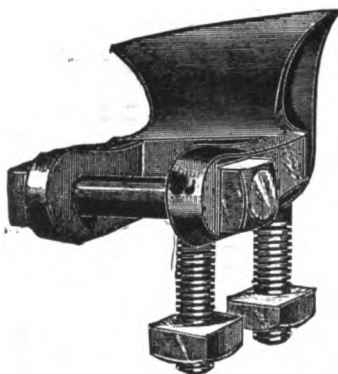

Skewed Shaft Couplings

**Regular or Oval Patterns
For High Arched Axles**

Furnished in rights and lefts for any height of arch. Oval Axle
Clips $\frac{5}{8}$ or $\frac{3}{4}$ width to match Oval Couplings. Bolts, Clips,
Couplings, Carriage Hardware and Special Forgings

Catalogue "H" and Prices on Application

COLUMBUS BOLT WORKS COMPANY
COLUMBUS, OHIO

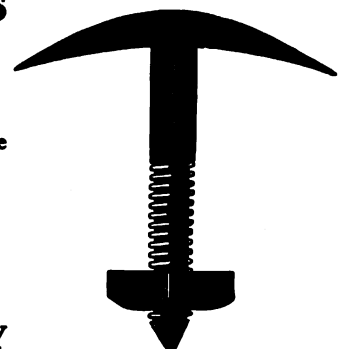

The Hub

First Journal of the Vehicle Industry

Vol. LVIII

SEPTEMBER, 1916

No. 6

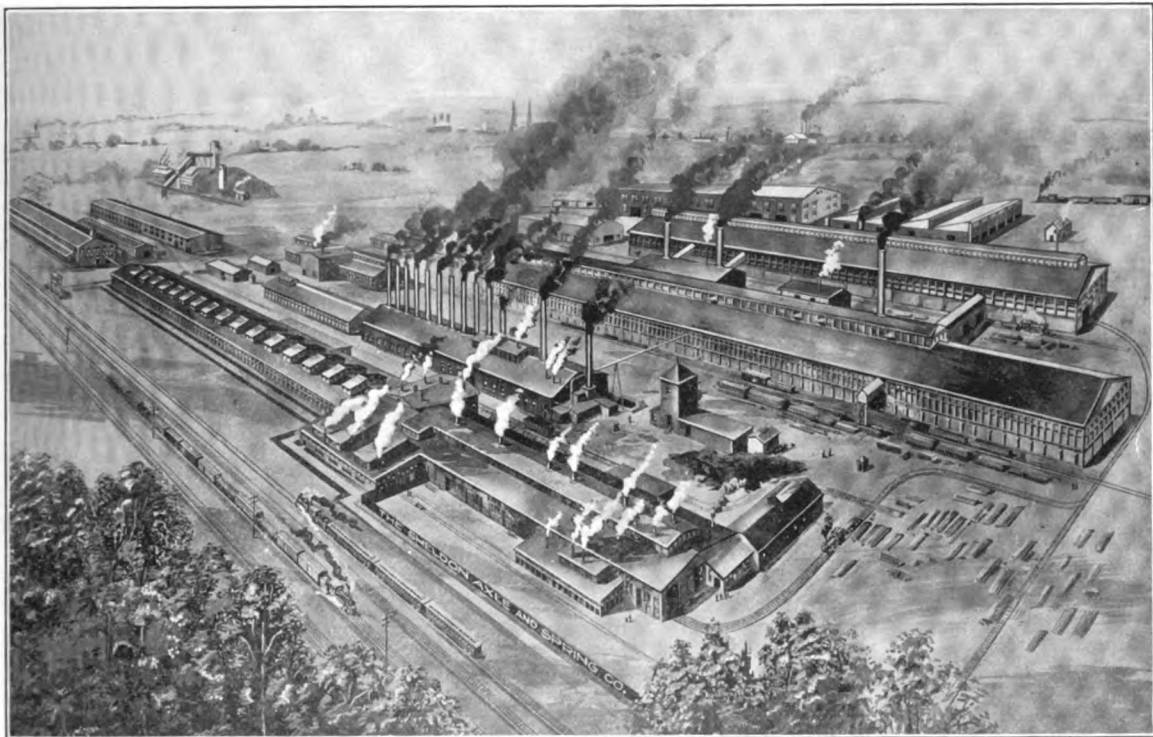

SHELDON

"The Name Internationally Famous"

FOR

SPRINGS AND AXLES

Sheldon Axle and Spring Company

Wilkes-Barre, Pa., U. S. A.

**Buy "Hickory Nut," "Acorn"
Vehicle Wheels**

You cannot buy better wheels dollar for dollar paid. A bad wheel is a big "Leak" in your business.

STOP THAT LEAK TODAY
By Asking Your Jobber for
WHEELS "MADE IN ST. MARYS"

Export Office: 8 Bridge St., NEW YORK CITY
Factories: ST. MARYS, O.; RICHMOND, VA.

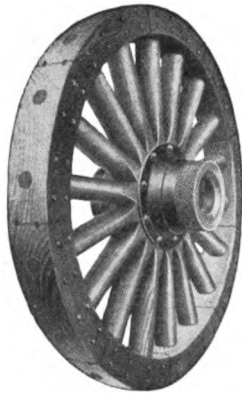

**and "Star" Brand
Carriage Woodstock**

We make a specialty of Spokes, Hubs, Bent Hickory and Oak Rims, Poles, Shafts, Singletrees, etc., for **New Work or Repairs.**

Buy "Star" Brand and be a satisfied customer.

INSIST ON OUR BRANDS

St. Marys Wheel & Spoke Co.
Consolidated with CRANE & MacMAHON, Inc.
ST. MARYS, O. :: U. S. A.

**DOEHLER
DIE-CASTINGS
IN ALUMINUM**

have been developed to a high state of efficiency. They have all the qualities that characterize our well known White Metal product with the additional features of being light in weight and possessing great tensile strength. Being delivered practically ready for assembling as accurate in most details as a machined product, they are extensively used by the most prominent Automobile Manufacturers in preference to machined parts—saving thereby the enormous "overhead" entailed by maintenance of costly machining equipment.

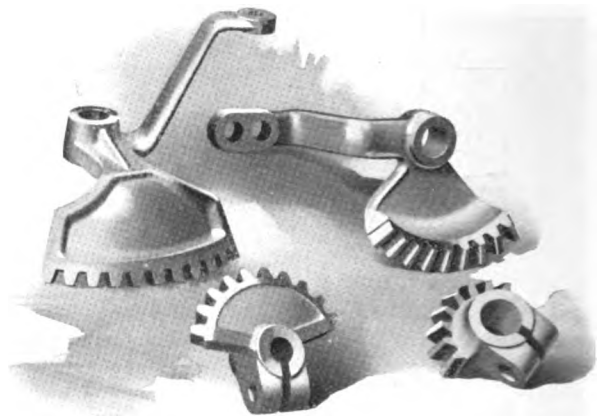

Aluminum die-cast control gears

DOEHLER DIE-CASTING CO.
BROOKLYN. N.Y.
NEWARK. N.J. TOLEDO. OHIO.



85-87 ADAMS ST.
BROOKLYN, N.Y.
Felts for the Automobile and Machinery Trades a Specialty
DUST RINGS FOR HUBS STRIPS FOR CRANK CASES
FELT WASHERS AND GASKETS FOR ALL LUBRICATING AND DUST EXCLUDING PURPOSES
No order too small to receive prompt and most careful attention

PORTER'S BOLT CLIPPERS
"Easy" "New Easy" Allen-Randall



To Cut 5-16, 3-8, 1-2, 5-8, 3-4 Inch.
H. K. PORTER, EVERETT, MASS.

"Quickwork" Sheet Metal Working Machinery

For Automobile and Carriage Bodies, Fenders, Hoods, etc.

H. COLLIER SMITH

807-815 SCOTTEN AVE. DETROIT, MICH.

A sure way to reduce your costs!

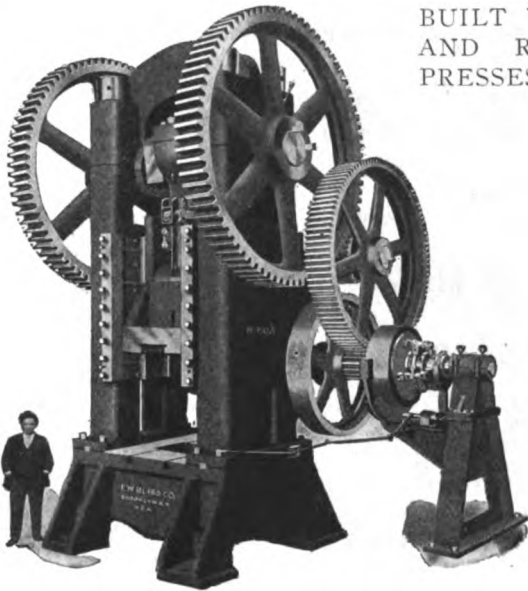

"Bliss" No. 80 1/2 Straight Side Press
Weight, 175,000 Pounds

BUILT WITH THE GREATEST POSSIBLE STRENGTH AND RIGIDITY, BLISS STRAIGHT-SIDE POWER PRESSES MINIMIZE THE MAINTENANCE COST OF BOTH MACHINE AND TOOLS.

Bliss Straight-Side POWER PRESSES

are being widely used for heavy punching, piercing, shaping, stamping and drawing operations in the manufacture of automobile parts, agricultural implements, electrical instruments, cutlery and heavy hardware. They are also adapted for trimming drop forgings, hot or cold.

Built in various sizes ranging in weight from 5,000 to 175,000 pounds.

We are anxious to send you full details.

Let us know your requirements and we'll be glad to offer you a few valuable suggestions. Write us at once.

E. W. BLISS CO.

38 ADAMS STREET

BROOKLYN, N. Y., U. S. A.

Chicago Office: 622 West Washington Boulevard
Detroit Office: Dime Bank Building



SCREW MACHINE PRODUCTS

TO B/P OR SAMPLE

METAL STAMPINGS

LIGHT OR HEAVY

CASTINGS

ALL KINDS

SEAMLESS TUBING

BRASS, COPPER, STEEL

Special Metal Products

manufactured to specifications

MURCOTT-DUDEN CO., Inc.

253 Broadway

New York



**Hundreds of Vehicle and Automobile Parts
Can Be Advantageously Produced in**

ACME DIE-CASTINGS

NO MACHINING! Ready to assemble as soon as you receive them. Unsurpassed in finish, accuracy and toughness.

STRENGTH—In our laboratory we have succeeded in compounding die-casting metals which are remarkable for their velvety grain and dependable uniformity.

ACCURACY—Acme Dies are guaranteed for an unlimited number of castings. Speed, temperature and pressure are so closely regulated during the casting process that variations between one casting and another are reduced to a minimum.

PROMPT DELIVERIES—We can safely promise a very large production from each die—in fact, your requirements must be very large if we cannot supply them well in advance. The daily capacity of Acme Die Casting Machines is greater than others—each Acme Die earns you larger profits because you are able to get more parts from it.

SERVICE—A business-like organization of die-casting experts is behind Acme Service. We are ready to extend the closest co-operation and technical aid in perfecting your product and reducing its cost.

We are now supplying Aluminum Die-Castings

Get our interesting quotations

Acme Die-Casting Corporation

Bush Terminal Bldg. No. 5

35th St. and Third Ave.

BROOKLYN, N. Y.

SALES OFFICES:

Boston—176 Federal St. Chicago—232 S. Clark St.

Philadelphia—

Detroit—

Widener Bldg.

965 Woodward Ave.

CANADIAN DISTRIBUTORS:

Lyman Tube & Supply Co., Ltd., Montreal



SHERWIN-WILLIAMS VEHICLE FINISHES

A PRODUCT FOR EVERY PURPOSE, PRODUCING DISTINCTIVE RESULTS

S-W METAL PRIMERS S-W BODY AND GEAR UNDERCOATINGS

S-W Q. D. COLORS S-W COLOR VARNISHES

S-W FINISHING VARNISHES

EFFICIENT IN QUALITY AND UNIFORMITY

The Sherwin-Williams Co.

CLEVELAND

CHICAGO

NEWARK

MONTREAL

LONDON, ENG.

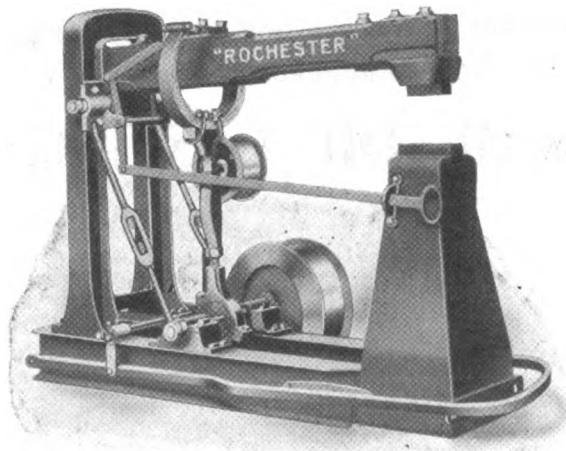

Rochester Helve Hammer

is a very convenient tool for carriage and wagon smith shops. Adapted to welding tires, axles and all general forging. Built in six sizes and reasonably priced.

Write for catalog.

The West Tire Setter Company
Rochester, N. Y.

CONTRACT TIME IS AT HAND

Do not fail to get our prices
before signing up for next year

We can furnish promptly standard
Shortsville Wheels

Quality Wheels at Right Prices are
A GOOD INVESTMENT

Write Us

Shortsville Wheel Co.

The Daylight Factory

Shortsville - - New York

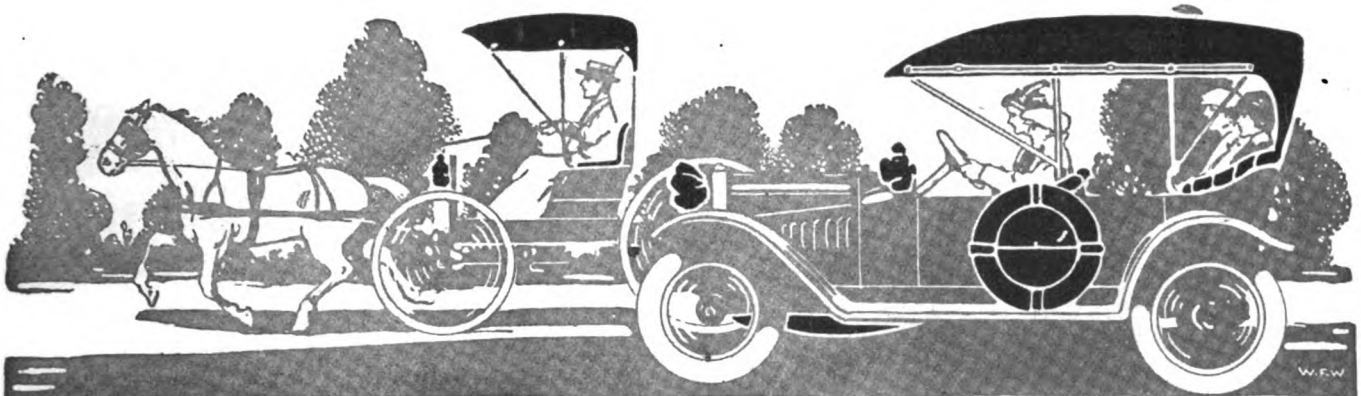

The Leading Leather Substitute For Carriage and Auto Trade

When you need a leather substitute, join the other progressive carriage and automobile manufacturers and select the leading leather substitute—

MERITAS

LEATHER CLOTH

A leather substitute is but a substitute after all—but Meritas leather cloth is made and finished to withstand the hardest wear and handling.

Meritas Leather Cloth is durable, of non-cracking finish and guaranteed perfect by our trademark stamped on the back of every yard. You will like the selection of colors and the lasting finish of this serviceable leather substitute.

Meritas Leather Cloth is made in muslin, duck and drill; dull or glazed; smooth or grained; in black and colors.

Learn more about this leading leather substitute by writing for sample book—sent on request.

Write
for
sample
book of
MERITAS
LEATHER CLOTH

NOW

The Standard Oil Cloth Co., Inc.

320 Broadway, New York

High Grade Forgings

for CARRIAGE, WAGON, AUTO-MOBILE and SPECIAL WORK

ECCLES BALL-BEARING COUPLINGS are the BEST on the MARKET for DURABILITY and EASE OF ADJUSTMENT

LEATHER BUSHINGS ARE FAST-ENED IN THE SOCKET WHERE THEY BELONG



Patented Nov. 25, 1902, and June 11, 1907

SPECIAL FEATURE—THE SPRING IS PIVOTED AT THE FRONT TO ALLOW EASY ADJUSTMENT

Please bear in mind that we make a FULL LINE of Carriage and Wagon Forgings, also many of those for Auto and Special Work.

Send for our new Catalogs showing our Regular and Special Forgings.

QUALITY GUARANTEED.

SERVICE—THE BEST

Richard Eccles Co.

AUBURN, NEW YORK

LAWCO

Sheet Metal Specialties

Buggy Seat Shells,
Commercial and Pleasure
Automobile Fenders,
Hoods, Dashes, etc.

Largest Individual Manufacturers of Sheet
Metal Accessories for the Ford Car



THE F. H. LAWSON CO.

Established 1816

CINCINNATI

OHIO

DU PONT
FABRIKOID

RAYNTITE Top Material

is a single texture, light weight, strong and pliable, water and weather proof topping sincerely guaranteed for one year's service, but made to last the life of the vehicle.

Top your vehicles with RAYNTITE—the widely advertised, warranted fabric.

Samples sent on request.

Du Pont
Fabrikoid Co.

WILMINGTON,
DEL.
TORONTO,
ONT.

Motor
Quality
Fabri-
koid
is The
Stan-
dard
Seat
Uphol-
stery.

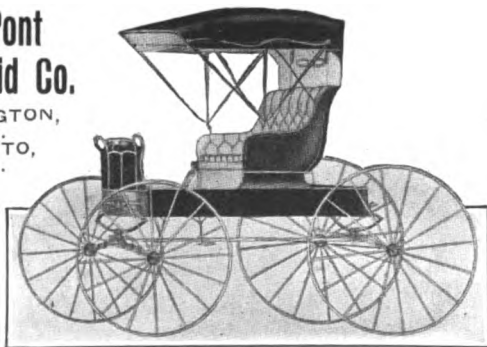

Catalog Building

Is similar to that of other products. The raw materials, *plus* expert designing, *plus* competent workmanship, *plus* the know how (and we have had over twenty-five years of the latter), *equal* the finished article.

The Cargill Company

Complete Printing Service

Grand Rapids, Michigan

AT YOUR SERVICE

80,000 SQUARE FEET of Floor Space Devoted Exclusively to the Manufacture of

Automobile, Carriage and Car Paints, Colors, Varnishes, Etc.

Entire plant reinforced concrete, equipped with automatic sprinkler system.

Power and light derived from direct-connected Corliss engine to A. C. generator of 200 k. w., also connected with central station power service.

All machinery motor driven, direct connected by silent chain.

Tankage capacity for crude liquids—linseed oil, turpentine, etc.—150,000 gallons.

Tankage capacity for clear varnishes and grinding liquids, 200,000 gallons.

6th floor—Manufacturing of dry colors.

5th floor—Storage of finished varnishes and shipping containers.

4th floor—Liquid color and mixing departments.

3rd floor—Grinding department—operating 100 mills.

2nd floor—Office, printing department, sample painting room, laboratory, machine shop and employes lunch and locker room.

1st floor—Shipping room and finished stock department.

Basement—Storage crude materials.

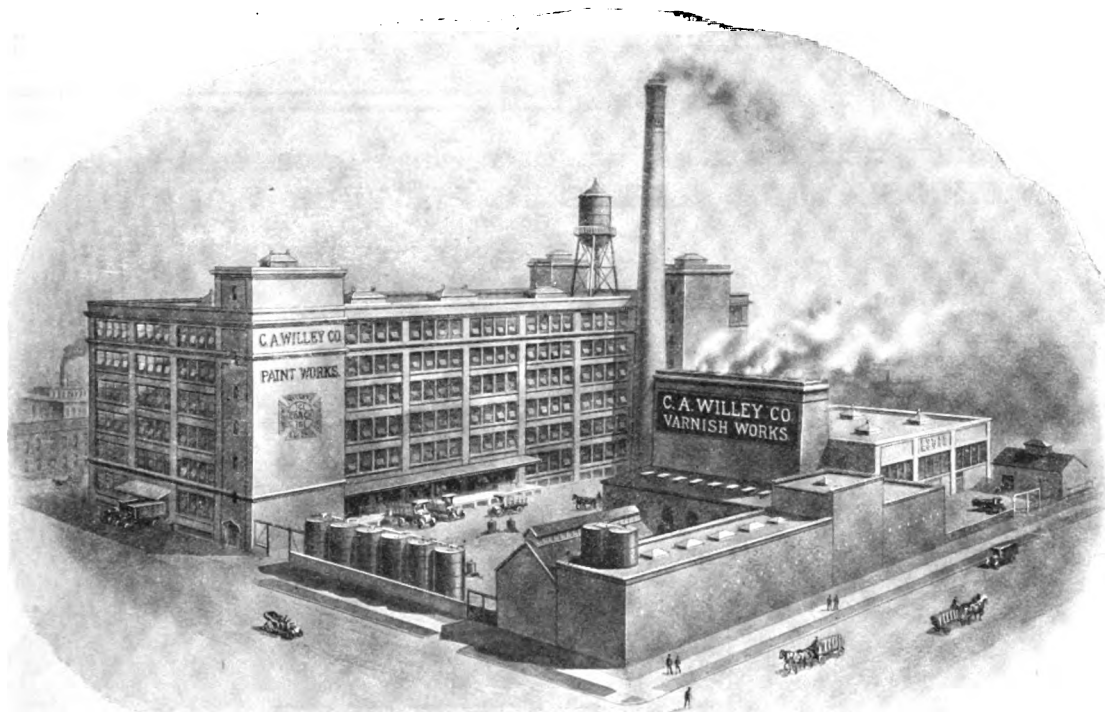

C. A. WILLEY COMPANY

Manufacturers of Specialties in

Automobile, Carriage and Car Paints, Colors, Varnishes, Etc.

NEW YORK CITY, U. S. A.

Split Leather

a substitute for and always inferior to

KERATOL

Any Finish All Grains



The Home of Keratol

Nothing but hair grain leather wears better than KERATOL!

SAMPLES AND PRICES UPON REQUEST

The Keratol Co.

South and VanBuren Sts., Newark, N. J.

You never need wind it



A step ahead in motor car equipment is the Hartford Electric Clock which winds itself, electrically, every minute. It is the only absolutely accurate electric clock offered to the automobile public today.

HARTFORD

SELF WINDING

ELECTRIC CLOCK

It operates either from the storage battery or on four No. 6 dry cells. No keys are required—it doesn't have to be taken apart to be wound.

Neither heat nor cold will affect its accuracy. It is immune to the effect of vibration. It is dust proof.

What more necessary accessory can you have on a car than a seven-jewel, high quality, specially-designed electric clock which will meet every severe condition to which such a clock may be subjected?

The Hartford Self Winding Electric Clock is guaranteed for one year.

Made in two styles—Model FA Flush Inset type; Model XA Extended type. Either model may be had in all nickle or all black with black or silver dials.

PRICE \$10

Get it from your dealer—if he does not carry it, write us. Ask for descriptive literature.

MANUFACTURED BY

THE HARTFORD CLOCK CO., Inc.,

6 CHURCH STREET, NEW YORK



CHOOSE YOUR CLAMPS TO FIT YOUR WORK



Capacities $\frac{1}{8}$ -12 $\frac{1}{4}$ "

Willams' "VULCAN", and "AGRIPPA" Clamps

afford abundant variety for all work



"Agrippa" Medium Service Clamps. Capacities $\frac{3}{8}$ -18"
 "Light Service" Clamps. Capacities 0-12"
 "Vulcan" Tool Makers' Clamps. Capacities 0-4"
 "Vulcan" Machinists' Clamps. Capacities 1 $\frac{1}{4}$ -4 $\frac{1}{4}$ "
 "Vulcan" Strap Clamp Six Classes.

Maximum toughness, strength and rigidity with minimum weight are procured only by our specialized heat treatment, drop-forged refinement and most approved design.

The first two inimitable! The last endorsed by imitation, the sincerest form of flattery.

Secure them from your dealer, assured that WE guarantee them.

J. H. WILLIAMS & CO.
 416 RICHARDS STREET BROOKLYN, N. Y. CITY
THE WRENCH PEOPLE

They won the "Grand Prize," the Highest Award at the P. P. I. E.

Western Office and Warehouse: 40 So. Clinton St., Chicago, Ill.

The Hub

INCLUDING Carriage and Wagon Builder and American Vehicle

Vol. LVIII

SEPTEMBER, 1916

No. 6

Published Monthly by

THE TRADE NEWS PUBLISHING CO. OF N. Y.

PAUL MORSE RICHARDS, *President* G. A. TANNER, *Secretary and Treasurer*

EDISON BUILDING, COR. ELM AND DUANE STS., NEW YORK

THE HUB, a monthly authoritative journal on all subjects pertaining to the vehicle industry from its engineering and construction viewpoints. It publishes information of live interest to manufacturers of motor vehicles, trailers, carriages, wagons, the accessory trades, repair shops and garages.

Subscription price for the United States, Mexico, Cuba, Porto Rico, Guam, the Philippines, and the Hawaiian Islands, \$2.00; Canada, \$2.50; payable strictly in advance. Single copies, 25 cents. Remittances at risk of subscriber, unless by registered letter, or by draft, check, express or post-office order, payable to the order of THE TRADE NEWS PUBLISHING CO.

For advertising rates apply to the publishers. Advertisements must be acceptable to publishers. Copy for new advertisements must be received by the 25th of the preceding month. All communications must be accompanied by the full name and address of writer.

Entered in the New York Post Office as Second-class Matter.

Announcement

The recent death of W. W. Wood, owner and editor of the Carriage and Wagon Builder, was one of those occurrences which sometimes prove that sole individual management has its disadvantages if not hazards. Mr. Wood's properties had to be liquidated, inclusive of the American Vehicle which had previously been consolidated with the Carriage and Wagon Builder. The Hub has purchased these combined journals from Mr. Wood's estate, and will fulfill its obligations to subscribers and advertisers.

Such an event justifies a little retrospection. The Hub, when it absorbed Stratton's New York Coachmakers' Magazine years ago, became the oldest journal in this country representing the vehicle industry in all its phases. The policy of broad, catholic representation of the vehicle industry was so generously carried out by the then proprietors that The Hub became international rather than national in scope and was recognized very generally abroad from this point of view. This position, and breadth of view it is the purpose of the present management, shall be steadily maintained.

As the craft of vehicle making developed and broadened into new fields The Hub not only kept pace with the evolution, but in some instances was a step or two in advance of trade development. This is especially the case in the matter of the automobile. The self-propelled vehicle was by this journal taken up, its first halting steps described, explained and its efforts illustrated at a time when the then vehicular world was in a scoffing, skeptical state of mind, and there was, for quite a period, no exponent of trade opinion other than The Hub that even recognized the advance ground onto which that newer vehi-

cle was turning its wheels which was destined in due time to become literally revolutionary in one branch of our industry.

Mention is made of this historical fact here in order to make the record chronologically accurate, and to express in another way that The Hub has always striven to recognize and conform to the spirit of the times. Many there doubtless are who have not had the means or rather the information at hand for checking up this interesting journalistic fact, in connection with The Hub's having been the earliest booster of the now powerful automobile branch of vehicledom.

The absorption by The Hub of the late Mr. Wood's periodicals referred to, clears the vehicle field of all but strong exponents. Probably no move could have been more advantageous to the business interests of this very large, modern and affluent industry in its manifold ramifications.

We trust it is not inappropriate and but a fair presumption for us to indulge in, to say that The Hub, the oldest journal in this field, the one that has outlived temporary successes, must have possessed the vitality, the worth, the influence and the prestige that has constituted its own sufficient reason for survival. Possibly the Darwinian theory may have here applied for 58 years, but in any event The Hub today feels better equipped and prepared to render devoted and intelligent service to its enlarged constituency than at any time in its past long, and we are proud to say, honorable and useful career.

Swiss Motor Car Industry Prospers

The war has boomed the Swiss automobile industry and given an increased impetus to their export trade. The absence of American automobiles in the streets and roads of this consular district is very noticeable. But three American cars have been seen there during the past six months. The reason for this is said by a local motor car agent to be the absence of American repair stocks in Switzerland, and the consequent high cost of repairs by local shops. Replace parts for American cars must either be imported from France or manufactured locally at a high cost, it is claimed. Moreover, foreign repair parts pay a considerable duty in Switzerland. Until this situation is overcome, little or no prospect seems to exist for the introduction of the American motor car on a considerable scale in this section. The prospective American automobile exporter would do well to bear in mind also the competition offered by the Swiss motor car industry. There are one or two Swiss cars of great reputation and wide sale, some of which compete successfully even in France. In normal times Switzerland imports about 750 cars a year.

Exhibitors at the C. B. N. A. Convention

Following are the names of the vehicle accessory firms and trade journals that have contracted for space at the Cincinnati convention of the Carriage Builders' National Association, September 26 to 29. This list, furnished by the secretary of the association, is complete up to September 6. A considerable addition will undoubtedly be made to this list before the doors of the exhibition hall are opened for the convention week display:

Alf Co., Edward F., Cincinnati. Vehicle Materials.
 Auto Vehicle Parts Co., Newport, Ky. Automobile Accessories and Parts.
 Backstay Machine & Leather Co., Union City, Ind. Leather Trimmings.
 Blacksmith and Wheelwright, New York. Trade Journal.
 Bradley & Son, C. C., Syracuse, N. Y. Shaft Couplings.
 Chase & Co., L. C., Boston, Mass. Trimmings and Top Fabrics.
 Cleveland Hardware Co., Cleveland, O. Hardware.
 Cortland Carriage Goods Co., Cortland, N. Y. Vehicle Accessories.
 Crandal, Stone & Co., Binghamton, N. Y. Hardware.
 Du Pont Fabrikoid Co., Wilmington, Del. Trimming and Top Fabrics.
 Eberhard Manufacturing Co., Cleveland, O. Hardware.
 Enterprise Brass and Plating Co., Cincinnati. Vehicle Mountings.
 Fairfield Rubber Co., Fairfield, Conn. Top Fabrics.
 Firestone Tire and Rubber Co., Akron, O. Rubber Tires.
 General Leather Co., Newark, N. J. Leather.
 Goodyear Tire and Rubber Co., Akron, O. Rubber Tires.
 Gregg Varnish Co., St. Louis. Varnish.
 Hub, The, New York. Trade Journal.
 Illinois Iron and Bolt Co., Carpentersville, Ill. Axles.
 Kelly-Springfield Tire Co., New York. Rubber Tires.
 Laidlaw Co., The, New York City. Trimming and Top Fabrics.
 Lawson Co., F. H., Cincinnati, O. Metal Seats.
 Liggett Spring and Axle Co., Monongahela, Pa. Springs and Axles.
 Monarch Carriage Goods Co., Cincinnati. Trimmings and Mountings.
 Mossman-Yarnelle & Co., Ft. Wayne, Ind. Vehicle Materials.
 Muncie Wheel Co., Muncie, Ind. Wheels.
 National Hardware Co., Cincinnati. Vehicle Hardware.
 Pioneer Pole and Shaft Co., Piqua, O. Poles and Shafts.
 Queen City Forging Co., Cincinnati. Vehicle Forgings.
 Raser Tanning Co., Ashtabula, O. Leather.
 Rielly & Son, P., Newark, N. J. Leather.
 Rose Manufacturing Co., Philadelphia. Lamps.
 Royer Wheel Co., Aurora, Ind. Wheels.
 Sheldon Axle and Spring Co., Wilkes-Barre, Pa. Springs and Axles.
 Smith & Co., Edward, New York. Paints and Varnish.
 Spokesman, The, Cincinnati. Trade Journal.
 Standard Varnish Works, New York and Chicago. Paints and Varnish.
 Union Bow Co., Cleveland. Bows.
 Vehicle Monthly, The, Philadelphia. Trade Journal.
 Western Spring and Axle Co., Detroit, Mich. Springs and Axles.
 Wilcox Manufacturing Co., D., Mechanicsburg, Pa. Hardware.

Wiley Co., C. A., Hunters Point, Long Island, N. Y. Paints and Varnish.

1916 State and Interstate Fairs

Following are listed the names and dates of the State and Inter-state fairs scheduled for the remainder of the year:

Peoria District Fair (under the auspices of the National Implement and Vehicle Show), Peoria, Ill., Sept. 26-Oct. 7.
 Alabama (State), Birmingham, Oct. 5-14.
 Arizona (State), Phoenix, Nov. 13-18.
 Colorado (State), Pueblo, Sept. 18-23.
 Georgia (State), Macon, Nov. 2-11.
 Illinois (State), Springfield, Sept. 15-23.
 Illinois (Peoria), Peoria, Sept. 26-Oct. 7.
 Iowa (Interstate), Sioux City, Sept. 18-23.
 Kansas (State), Hutchinson, Sept. 16-23.
 Kansas (State Association), Topeka, Sept. 11-16.
 Kentucky (State), Louisville, Sept. 11-16.
 Louisiana (State), Shreveport, Nov. 1-16.
 Michigan (West) Grand Rapids, Sept. 18-22.
 Missouri (State), Sedalia, Sept. 23-30.
 Mississippi (State), Jackson, Oct. 23-28.
 Montana (State), Helena, Sept. 25-30.
 New Jersey (Interstate), Trenton, Sept. 25-29.
 New York (State), Syracuse, Sept. 11-16.
 North Carolina (State), Raleigh, Oct. 16-21.
 Oklahoma (State), Oklahoma City, Sept. 23-30.
 Oregon (State), Salem, Sept. 25-30.
 South Dakota (State), Huron, Sept. 11-15.
 Tennessee (State), Nashville, Sept. 18-23.
 Tennessee (Tri-State), Memphis, Sept. 24-Oct. 3.
 Texas (State), Dallas, Oct. 14-29.
 Utah (State), Salt Lake City, Oct. 27.
 Vermont (State), White River Junction, Sept. 12-15.
 Virginia (State), Richmond, Oct. 9-14.
 Washington (State), North Yakima, Sept. 18-23.
 Wisconsin (State), Milwaukee, Sept. 11-16.
 Wyoming (State), Douglas, Sept. 26-29.

C. H. A. T. Committee Arranges for Convention

The Cincinnati committee of the Carriage, Harness and Accessory Traveling Men's Association held a meeting recently for the purpose of arranging details of the annual convention, to be held September 25-30, the same week as the C. B. N. A. convention. The following gentlemen were present: J. A. Niehaus, H. C. Jay, W. F. O'Brien, G. W. Huston and C. J. Rennekamp. The members may rest assured that the committee is arranging some innovations, and that the 1916 convention will be in line with past achievements of the organization.

Show Space Application Blanks Sent Out

Application blanks for space at the New York and Chicago shows have been sent out by the National Automobile Chamber of Commerce to the various car makers, with instructions to fill them out and return them by September 30, if the applicants wish to be included in the first drawing for space, to be held October 5. The New York show will be held January 6 to 13 in the Grand Central Palace, and the Chicago show January 27 to February 3, in the Coliseum and Armory.

Safety in Sand-blasting

Preparing metal surfaces for a covering of paint has given rise to extensive use of the sand-blast, especially in the large-production automobile factories. When the outfits are constructed of sufficient size to accommodate large surfaces such as mud guards, hoods and bodies, the problem of protecting the workmen has presented serious diffi-



The old style sand-blast. The operator is free to discard his headgear when he finds it cumbersome

culties. Various forms of safety devices for the operators of the sand-blast nozzles have been tried, including the familiar respirator with a sponge through which the operator breathes, and various forms of helmets, similar to a divers' dress, in which fresh air is supplied under pressure. The first renders it difficult to breathe; the second

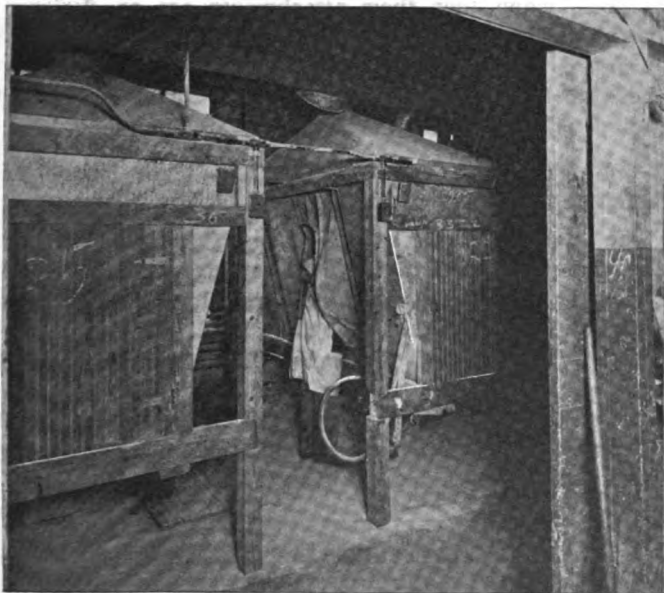

New sand-blast (outside). The operator must put his head in the protecting mesh to see his work

type is often so cumbersome that it is discarded by the workmen at their own peril. In fact, the history of the use of safety sand-blast devices has proven conclusively that when these may be used or detached at will by the

workmen, they are usually discarded, even if such neglect constitutes positive danger.

This difficulty has been overcome in the apparatus pictured herewith, in which it is necessary for the operator to use the safety helmet if he is to work at all. Each sand-blast room is a small compartment of the double hopper type in which the heavy particles of sand used in the cleaning process are drawn out of the lower hopper and the lighter particles out of the upper by air suction. The material to be cleaned is laid on a grating between the two hoppers. It is introduced into the compartment through a door at one end. The sand-blast operator's screen at the front is securely attached to the inside of a curtain which forms the front wall of the compartment. This curtain is fastened to sliding metal doors which can



New sand-blast (inside). Operator stands outside the little cage and works inside it

be moved horizontally from side to side. In this way it is impossible for the operator to see into the interior of the compartment until he puts his head in the helmet. This being accomplished he stands on the floor outside the compartment, moving along as is necessary in the progress of his work by pushing the sliding metal doors to either side with his elbows, as shown.—Jos. Brinker, in *Scientific American*.

Miniature Car to Compete With Jinrikisha

The American Junior, a little car carrying two passengers, is to be built at Indianapolis, Ind., to compete with the jinrikisha in China and for juvenile trade. It will have a 40 in. tread and a 70 in. wheelbase, and will be built by the American Motor Vehicle Co., Lafayette, Ind. The officers are: Jacob Weisenthal, Lafayette, president; Louis Marx, Chicago, vice-president; and W. M. Crockett, Lafayette, secretary. B. J. Mills, Chicago, is one of the principal stockholders. The capital is \$25,000.

A Sign of the Times

Over the name of a well known Melbourne firm of undertakers the following advertisement recently appeared in the daily press: "Hearse and Carriages, in good order, for sale; sacrifices to make room for motors."

Possible Restrictions Against Importation of Motor Cars in Australia

According to Consul General J. I. Brittain, Sydney, New South Wales, the impression appears to be gaining ground in commercial circles that the government of Australia may prohibit the importation of motor cars on the ground that they are luxuries, the importation of which should not be encouraged during the war. If importation is not prohibited, a restriction, or the imposition of a higher tariff, is regarded as probable. A good percentage of the motor cars imported into Australia are not for pleasure purposes, but for use on sheep and cattle ranches where there are no railways. Aside from the excellent market here for motor cars, there is also a good market for motor trucks.

The excessive price of gasoline also operates against the sale of motor cars. At present a company is prospecting for petroleum in South Australia, where there is a decided seepage of asphalt which the company thinks indicates the presence of petroleum. The well at present is down 1,200 feet.

It is scarcely necessary to say that the chief obstacle to American trade expansion with Australia is the American exporters' inability, on account of insufficient tonnage, to send forward merchandise when orders are placed. Another hindrance is the high freight rates, especially from Atlantic ports. Notwithstanding the excessive freight rates, which have resulted in the canceling of orders, American sales would have been much larger had tonnage been available.

We need more direct or resident representatives from our manufacturers and exporters. Naturally, small exporters' profits will not justify special representatives, but more of our large manufacturers would find advantage through direct representation. One need only observe the sales of machinery, motor cars, motorcycles, textiles, ready-made garments, pianos, steel products, silks, railway supplies, electrical machinery, sewing machines, oils, motor tires, typewriters, glass and glassware, etc., to be thoroughly convinced how direct representatives have caused our trade to increase in Australia. Rather than endeavor to compel the Australian businessman to adopt our methods, we should study more closely his banking and other business methods. The polite, courteous representative is especially needed at this time.

Chewing Gum and Auto Tires on Same Growth

According to a dispatch in the daily papers from Phoenix, Ariz. a million-acre orchard on the Great American Desert is today growing chewing gum and automobile tires on the same plant.

It sounds like a nightmare, but it isn't says the dispatch, which continues:

The despised ocotillo, a species of cactus, is the plant. The sun baked herbage of the sands has come into its own.

The branches of the ocotillo contain rich quantities of a chicle superior to any produced in Mexico, whence comes the chief supply of this material for the manufacture of chewing gum.

What is more important is the fact that it produces

rubber of the finest quality. One of the big automobile tire companies has recently completed experiments with the Arizona ocotillo which thoroughly demonstrated its practicability as a rubber product. Other successful experiments indicate the possibility of a complete revolution in the rubber industry.

Chemist Jefferson D. Crawford, of San Francisco, discovered the commercial value of the ocotillo and will direct a \$300,000 corporation, which has already been organized, to reap the fruitage of the plant. George Harben, First Assistant Attorney General of Arizona, is secretary of the company. Col. Thomas Weedin, Registrar of the Federal land office at Phoenix, is a member and many other prominent Arizonans are stockholders.

The ocotillo grows on desert soil utterly unfitted for any other purpose. It is claimed that as much as 400 tons may be taken from an acre. New growth will reach maturity in from three to five years, making the supply inexhaustible.

It is the plan of the company to lease the desert lands from the state—a million acres or more—and remove the cactus from time to time for manufacturing purposes. Free use of the land for range would be permitted.

The first extraction of gum from the plant is to be made in portable factories operating in the field. The first unit of a stationary factory will consist of a grinding machine, disintegrator and distilling tank, with a capacity of 600 tons of gum daily.

Can Turn Car Into Light Tractor

The E. G. Staude Manufacturing Company, St. Paul, has undertaken the manufacture of attachments for Ford cars which enable the owner to turn the car into a light weight tractor. The necessary parts can be attached in a short space of time and do not necessitate drilling holes or defacing the car in any manner. The change back to a motor car is made with equal facility. The manufacturers claim that their attachments are so designed that all of the pulling is done by the tractor attachment, and not by the car itself, because all of the moving power comes from the contact of the rear wheels with the ground. The necessary attachments are inexpensive.

Harvey Spring Inaugurates Profit Sharing

The Harvey Spring and Forging Company, Racine, Wis., has distributed among its employes checks equal to from one to five per cent of the annual wage, depending upon the length of continuous service. The company expects to make this profit-sharing plan a regular feature, the bonus to be paid each year, about August 1. All men in continuous service for one year received one per cent; two years, two per cent; three years, three per cent; four years, four per cent; and five years or more, five per cent.

Horses Increase Despite Motors

Despite the growing use of automobiles in the state of New York during the last decade the number of horses shows an increase, according to the census of live stock of the state in 1915, taken by school children, as compared with the United States census in 1910. The number of horses and colts is given as 1,078,545, or an increase of 108,000 horses over five years ago.

The Doble Steam Car

Abner Doble, who has been experimenting with steam cars for several years, has perfected his vehicle to such an extent that a company has been organized in Detroit to be known as the General Engineering Co., with Doble as one of the officers. The company is to build a number of these vehicles with bodies designed by Holbrook. The cars will be of the high price class and all the appointments will be the best. The company also plans to license manufacturers to make the Doble type of steam propulsion, which can be made to meet the requirements of any chassis.

The Doble car employs a vertical-tube steam generator placed under the hood, where the engine would be in a gasoline car; under this is placed a combustion chamber lined with a refractory material. Kerosene is introduced here, and ignited by a point, electrically heated to a temperature sufficient to ignite the kerosene. The steam is then passed back to a two-cylinder engine mounted in unit with the rear axle. A condenser is utilized, so that the steam is re-converted into water and used over again. The kerosene tank is mounted at the rear of the chassis, just as a gasoline reservoir would be carried.

The car starts practically instantaneously, although steam is not already up. All that is necessary to start the

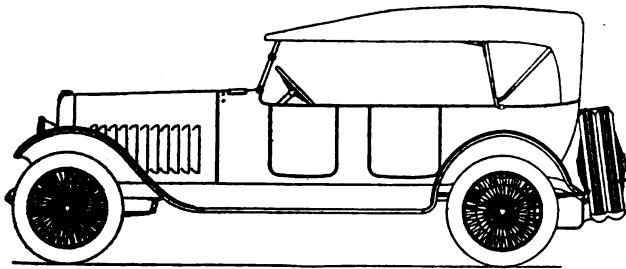

Lines of the Doble steam car

car is to turn the switch to the running position. This heats the igniter point and ignites the fuel. Then the throttle is opened and the machine starts immediately. In case the car has been inactive for several days, so that everything is cold, it takes about 1½ minutes to start, but after a wait of a few hours, such as over night, the machine can be started at once. In case the electric switch is left in the running position, the steam pressure remains at the normal point continuously.

Power is transmitted to the rear axle by spur gears, a 47-toothed gear on the engine crankshaft and a 49-toothed gear on the differential. No clutch nor gearset is used. Reduction gears are not required. This was demonstrated. The engine had more power than was needed to spin the wheels from rest on a dry pavement.

The water tube generator consists of a number of identical sections placed in an insulated casing. These sections consist of two horizontal headers connected by 16 vertical tubes. The headers and tubes are made from cold drawn seamless steel tubing, and the tubes are welded to the headers by the autogenous acetylene process, making the section of one piece of steel. The tube is swaged down to about 3/8 in. at the weld, thus reducing the amount of welding required and also making the weld stronger than if it were the full diameter of the tube. About one-third of the sections are used as the econo-

mizer, and the remaining sections form the evaporating part of the generator.

The water enters the generator through the lower headers of the economizer and rises through the tubes to the top headers, becoming heated on its way by the gases that have passed through the evaporator portion of the generator. From the top headers of the economizer the water is fed through a pipe to the bottom headers of the evaporator sections. The water level is maintained automatically about half way up the generator.

The steam rises through the upper part of the tubes,

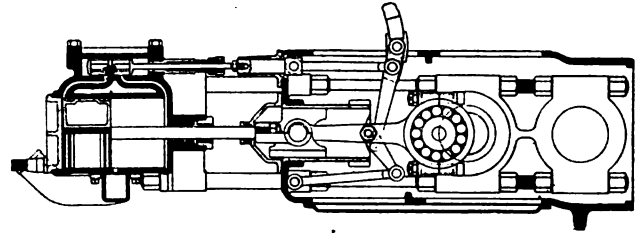

Plan section of two-cylinder type steam Doble engine

becoming superheated on the way, and goes out through the upper headers into the steam pipe, where it is led to the engine. The amount of steam passing is regulated by a throttle valve. The combustion takes place in a combustion chamber of efficient design, made of a special refractory material, which attains a very high temperature, and insures efficient combustion, by heating the gases before they burn, and by catalytic action. The gases rise past the tubes of the evaporator portion, and are then passed over a bridge wall and down past the tubes of the economizer portion, where the remaining heat units are abstracted by the relatively cool water entering the generator by way of the economizer.

The fuel is burned by means of a system that eliminates any attention or labor on the part of the driver, and reduces the time necessary to start the car from cold by the amount formerly necessary to properly pre-heat the vaporizer. This has been accomplished by taking a few pointers from internal combustion motor design, broadly following the same idea whereby air is made to pass through a device which mixes into it a correct amount of fuel, then this mixture is led into the combustion cham-

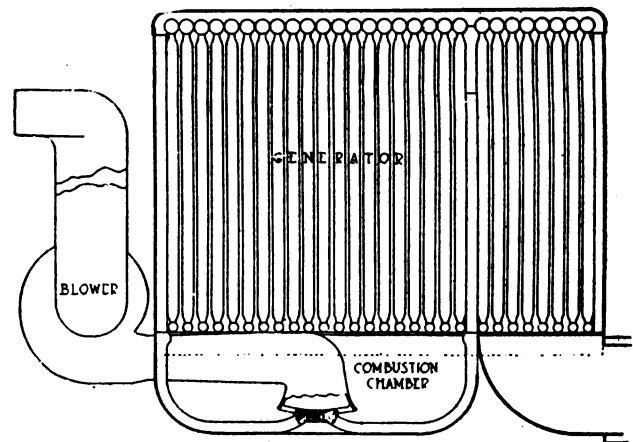

Water tube type steam generator

ber described above in connection with the generator, where it is ignited by means of electricity. In order to cause the air to flow a small blower is used, and is driven by an electric motor, such as is used in vacuum cleaners.

This blower forces air through the carbureter into the combustion chamber.

The steam is used in a simple, uni-flow, double-acting, two cylinder, locomotive type, steam engine, with a bore of 5 in. and a stroke of 4 in. This type of steam engine is one in which the steam travels through it in one direction only; that is, it goes from the cylinder head to the center exhaust port. The slide valves are on top of the cylinders, and are actuated by a Joy valve-gear. This gear dispenses with the need for eccentrics, thus making a one-piece crankshaft possible, and gives a superior steam distribution. The gear also reverses the engine without the need of extra devices. The cut-off can be set at any desired point, three being the usual number of cut-offs provided. In operation three-quarters cut-off is used for starting or heavy going, three-eighths for ordinary running and accelerating and one-eighth for high speed and high economy work.

The steam after it has done its work in the engine, is led to the top of the radiator and, in passing down through the tubes, gives its heat up to the air passing through the radiator and condenses into water. The water of condensation returns to the water tank, where it enters near the bottom, so that at nearly all times the opening is below the surface of the water. Piston rods pass through special solid cast-iron glands, which are made such good fit on the piston rod that no steam can blow by. Due to the long bearing surface there is practically no wear, and never any need for repacking, it is said.

The crankcase is an aluminum casting, well proportioned, and contains the entire moving parts of the engine except the pistons and valves. The differential is also contained in the crankcase, and the taper-tubes of the axle bolt directly to it. Thus the engine and rear axle are one unit.

The main bearings, and the big end connecting rod bearings are annular roller, and are of such proportions that no wear should occur during the natural life of the car. All of the other bearings such as the wristpins and valve gear bearings are hardened steel, running in hardened steel bushings.

The power is transmitted to the rear axle by means of two perfectly cut spur gears, a 47-tooth gear on the engine crankshaft and a 49-tooth gear on the differential. There are no change-speed gears and no clutch, and the engine has more power than is needed to spin the wheels from rest on a dry pavement, as was demonstrated.

To take care of the lights, horn and combustion system, the electric system comprises a dynamo and a storage battery. The dynamo is driven from the main axle drive gear.

Philadelphia Class in Vehicle Drafting

The school of vehicle drafting at the Central Branch, Y. M. C. A., 1421 Arch street, Philadelphia, will open its fall term on Monday, October 2. This course is under the auspices of the Carriage and Wagon Builders' Association of Philadelphia. A competent instructor will be in charge of the class.

The course in vehicle drafting is divided into five parts. Parts A and B must be finished by all students entering the classes. After these are completed, the student has the option of taking up Courses C, D or E, according to

the line of work in which he desires to perfect himself. Terms are very reasonable, \$7 for the eight months, in addition to a Y. M. C. A. membership costing \$2 per year.

Following is a synopsis of the different courses:

Course A—Preliminary instruction bearing upon the geometry of vehicle designing and building. Curves and ovals; simple side elevations; front and back elevations and bottom views of straight and curved surfaces; methods of laying out these views on the draft.

Course B—Practical problems in vehicle drafting. Geometrical problems relating to carriage, automobile, wagon and motor truck building. How to obtain the different bevels, inclinations, contractions and lengthenings. The dihedral angle. Making patterns for inclined and contracted pieces. How to cut the end surfaces, and lay out on the draft the thicknesses and shapes of all the pieces of the body frame work.

Course C—Drafting of bodies for horse-drawn carriages. Light and heavy carriages, their dimensions, as width, length and height; straight and curved surfaces; laying out the working draft for straight, squared, contracted and inclined parts. The combination of the parts, known in practice as "framing."

Course D—Horse wagons and motor truck bodies; plain and fancy. Designing attractive bodies. Various styles of commercial bodies and methods of framing and paneling the different kinds. Dimensions, lengths, widths and heights. The suspension of light, medium and heavy wagon bodies and trucks, including one, two, three and four-horse gears.

Course E—Automobile body drafting. Light and heavy pleasure car bodies; dimensions and proportions in relation to the chassis; widths and lengths relative to the comfort of the passengers. How to lay out the parts on the working draft and how to frame all parts on the body. Obtaining the nagles for seats and bodies. The construction of movable tops (hinges included).

Death of Jared Maris

Jared Maris, well known in the carriage building trade as a writer on vehicle matters, and for six years, beginning with 1882, as editor of the Carriage Monthly, died August 22, from the infirmities of age at his home at College Hill near Cincinnati, O., at the age of 86 years. He was a powerful exponent of timber and forest conservation and a recognized authority on wheel construction and wheel materials. For years after retiring from the editorial chair he contributed valuable articles until advanced age made it impossible for him to continue. There was a vein of optimism in the writings of this kindly old gentleman, and, although critical, was constructive and helpful in his views.

Whitney Carriage Co. Employes Get Bonus

The F. A. Whitney Carriage Co., Leominster, Mass., one of the largest industries in that section, and one which runs steadily every week in the year, posted in its shops on July 17 a bulletin that interested every employe. The bulletin gave notice that all employes who were in the Whitney service July 1 would receive a bonus of 5 per cent on the amount of their wages for the past year. This arrangement applied to all who had been in the employ of the company one year or more.

Standardization of Axle Spindles, Axle Boxes, Wheel Hubs and Flanges

In accordance with a call issued on April 11 for a conference to be held by the leading manufacturers interested in the above subject, meeting was held in Cleveland on Tuesday, April 25. At this meeting and in subsequent conferences, "Standard Specifications" were agreed upon as representing the most practicable and scientific "standardization" of lengths for axle spindles and boxes, wheel hubs and flanges, and the table on following page shows the result.

The spindle lengths, flange sizes and hub sizes shown are to be known as "standard sizes" and are the only ones which are hereafter to be carried in stock. All other spindle lengths, flange and hub sizes will be considered as "odd sizes" and are not expected to be carried in stock, but will have to be made up after receipt of orders.

As the shortage of material which now distresses the vehicle trade can be relieved only by immediate general approval of the "standard specifications," and as the axle, wheel, malleable iron, buggy and wagon trades have all participated in this effort, giving it their sanction and approval, the committee hopes all will extend their active support in establishing the "standards" on a permanent basis.

Following are the minutes of the standardization conference held in Cleveland, April 25, 1916, at which the following were represented:

Associations—Hickory Products Ass'n., Chicago, Ill. H. A. Long, secretary; Carriage Builders' National Ass'n., Cincinnati, O., Emil E. Hess; Eastern Wheel Makers' Ass'n., Philadelphia, Pa., E. H. Archibald.

Axle Manufacturers—Cleveland Axle Mfg. Co., Canton, O., J. B. Childe, vice-president and general manager; Illinois Iron & Bolt Co., Carpentersville, Ill., H. C. McNeil, treasurer; Liggett Spring & Axle Co., Monongahela, Pa., J. H. Neuhart, secretary and treasurer; Sheldon Axle & Spring Co., Wilkes-Barre, Pa., J. F. Armstrong, secretary; Spears Axle Co., Wheeling, W. Va., Andrew Reitz, secretary and general manager; Timken Roller Bearing Co., Canton, O., C. C. Staley, eastern sales manager.

Wheel Manufacturers—Archibald Wheel Co., Lawrence, Mass., E. H. Archibald, treasurer; Avoca Wheel Co., Avoca, N. Y., C. D. Carroll, general manager; Bookwalter Wheel Co., Miamisburg, O., Chas. L. Bookwalter, secretary and manager; Crane & MacMahon, St. Marys, O., J. J. Weisner; Hoopes Bro. & Darlington, West Chester, Pa., E. S. Darlington, treasurer; Muncie Wheel Co., Muncie, Ind., O. B. Bannister, president; Mutual Wheel Co., Moline, Ill., J. A. Condo, assistant secretary and treasurer; Pinneo & Daniels Co., Dayton, O., A. N. Wilcox, president and general manager; Zwick & Greenwald Wheel Co., Dayton, O., L. H. Rogge, vice-president.

Carriage and Wagon Manufacturers—Sayers & Scoville Co., Cincinnati, O., Emil E. Hess, sales manager; Studebaker Corporation, South Bend, Ind., A. C. Hill, H. V. Kimble.

Flange Manufacturers—Albion Malleable Iron Co., Albion, Mich., H. B. Parker, vice-president and assistant general manager; Dayton Malleable Iron Co., Dayton, O., W. H. Cassel, secretary; Erie Malleable Iron Co., Erie, Pa., A. J. Sterrett, secretary; The National Malleable Castings Co., Cleveland, O., C. W. Hotchkiss, manager, J. H. Rehhead, sales agent, R. L. Lehman.

The meeting was called to order at 10:30 a. m. O. B. Bannister, chairman of the statistical committee of the Carriage Builders' National Association, was elected chairman; Messrs. R. L. Lehman and H. A. Long were elected secretaries.

The purpose of the meeting was stated to be that of recommending to the vehicle trade, including accessory manufacturers, and securing the adoption of standard lengths for axle spindles, axle boxes, wheel hubs and wheel flanges, together with standard practice for the use of each of these parts in conjunction with the others.

Statement of the conditions suggesting the proposed action and arguments offered in favor of standardization may be summarized as follows:

Assurance of practical and scientific dimensions for axles and wheels with reference to vehicle loads.

Assurance of standard and correct practice in the use of wheels and axles in conjunction with each other.

Simplification of manufacture with production centered on necessary parts and elimination of all unnecessary or odd sizes and parts.

Adjustment of the supply to demand, or in other words, opportunity for manufacturers to make up stock intelligently in dull periods and thus be prepared to supply the demands of busy periods such as the present. Heretofore it has never been possible to accurately predict what sizes or styles would be required, and stocks built up or accumulated in anticipation of business have, therefore, frequently turned out to be dead stock; at the same time, stocks of other sizes have been entirely exhausted when the greatest demand developed.

Opportunity for making more prompt deliveries of parts and, therefore, of finished vehicles.

Necessity for all accessory people to co-operate in furnishing parts which can be used together, so that the construction of vehicles need not be unnecessarily delayed through inability to secure axles and wheels using the same length of axle box.

Reduction in the variety of stocks carried by manufacturers and dealers, thereby permitting:

Release of capital now unnecessarily tied up and frequently lost on account of dead stocks.

Reduced costs resulting from elimination of dead stocks.

Better labor conditions obtainable at piece work rates on account of larger and more uniform runs. At present the shortage of labor is a most serious question and is felt especially in the malleable iron business, which is, therefore, very seriously handicapped and can not possibly induce molders to handle the wide range of patterns heretofore demanded by the trade.

Economies which should better enable the horse-drawn vehicle trade and accessory business to compete with the automobile trade.

It was decided that the method of procedure necessary to accomplish results should be:

By agreement on a proper length of spindle or box for each axle size or diameter.

By agreement as to the correct diameter and length of wood hub for each axle size.

By agreement as to the correct diameter of spoke and length of flange (front and back) for each hub size.

The axle manufacturers present submitted recommendations for the correct lengths of spindle and axle boxes.

The wheel manufacturers then prepared the specifications for hubs, spokes and flanges.

Special action was taken upon several matters as follows:

Back flanges large enough to take the largest colling collars now used on any particular size of axle were selected.

Eight hole flanges and 16 spoke wheels only will be carried in stock and furnished in all sizes, except that 9 holes and 18 spokes may be ordered for No. 39 wheels and larger.

All wood hubs, compressed band and shell band wheels must conform to hub lengths given in table of standard specifications.

Recommended practice for "cupping" of wood hub is shown and thickness of nuts and collars is limited by dimensions of front and rear extensions on each size of axle and wheel.

The new standards are to be adopted at once for all new vehicles except for such variations as may be necessary to accommodate and even up present stocks on hand.

After January 1, 1917, manufacture of all odd sizes should be discontinued and no orders accepted, except for repairs.

The table embodies the specifications and shows the standards recommended by the conference.

Copies of the minutes were ordered sent to all manufacturers represented at the conference, and also to those invited to be present, with the request that the minutes and the table be given careful study and acknowledged promptly with the approval or suggestions of all parties.

If no important or necessary changes are suggested, it will be considered that the table is adopted as standard specifications.

It will then be printed and available for circulation throughout the entire carriage, wagon and jobbing trade.

The trade papers are to receive copies with privilege of publication.

The various trade associations are to be supplied with copies and requested to give the standard specifications official recognition.

Munger Contests Perlman Patent

Louis De F. Munger, at one time interested in tire manufacture, but later a creator of fine body styles, filed suit on September 13 against Louis H. Perlman and the Perlman Rim Corporation, of New York, for infringement of the Munger patent, No. 638,588, which was issued back in December 5, 1899. As the Perlman patent was not filed until June 29, 1906, Munger has a clear case if the United States District Court sustains his contention that the Perlman patent and the practice of the Perlman Rim Co. and its licensees infringes his claims.

The patent upon which suit is brought describes specifically a "combined elastic and pneumatic tire," involving the combination with a circular tire of a hollow metallic base, conforming to the shape of the tire, to which it is positively united, above, and to the shape of the felloe band below. For purposes of attachment the band and rim are described as being tapered, while the tire is held in place by means of a removable flange ring secured by through bolts. For this combination it is claimed in the briefest of the six claims allowed (Claim 4):

"In combination with a tapered felly, a tire, an annular rigid base to which said tire is secured, said base having

a tapered under surface and fitted on said felly, substantially as described."

Munger's case, as concerns the point of rim support, is based on a line of reasoning converging toward that of Erle K. Baker, of the Universal Rim Co., who also is suing Perlman for infringement of not one but many patents. Baker's practice involves the mounting of the rim upon a conical seat by the application of lateral pressure.

Munger's activities are interesting because the patent in suit has less than three months to run, and because his invention was cited by Judge Hunt, in deciding the noteworthy case of Perlman against the Standard Welding Co., in August, 1915. His lack of activity up to the present time the inventor explains by indicating that from the date of its issue until September 5 of the present year, the patent was in the hands of the National Wheel & Traction Co., of New York, to which it was originally assigned. Judge Hunt's reference to Munger's activities, classing it with several others, "involving demountable rims held tight upon their wheel bodies by conical fit or bolts pulling the rim against the wheel bodies," was, however, to another patent, No. 638,590, which was also issued in 1899, and not to the patent now at issue.

New Radiator Principle

An ingenious principle for radiator construction, the water circulating round three sides of each tube, has been invented by L. N. Anderson of Switzerland. The arrangement by which the water is made to flow freely round a number of right-angle bends is clearly shown in the illustration. While principles of this sort require also some practical tests under varying conditions it seems quite probable that the cooling efficiency would be considerably

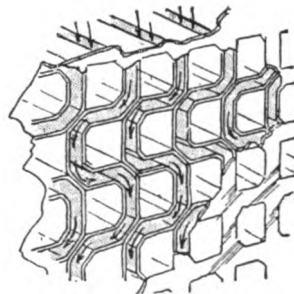

increased owing to the greater distance the water travels exposed to air draught, and some reduction of radiator size might result.

Ideal Army Truck Evolving

Military transport experts believe efforts to develop a motor truck capable of meeting the needs of the army campaigning along the Texas border and in Mexico will cause the manufacture for commercial use of an ideal truck within the next two or three years. The army transport board has been in session in Washington recently considering the preparation of specifications for each type of truck required by the army, upon which truck makers will be invited to bid.

The board found that the tests to which the army trucks were subjected on the border and in Mexico were the most severe that had been had in any part of the world. The conditions of service were quite abnormal, yet the performance of some of the trucks was remarkably good. Experts of the S. A. E., acting on the suggestion of the board, now are on the Mexican border studying at first hand the unusual conditions of weather, sandy grit and alkali existing there with a view to the still further improvement of the army trucks.

August Auto Shipments 18,254 Carloads

Shipments of automobiles during July totaling 18,079 freight carloads were reported to the directors of the National Automobile Chamber of Commerce at their monthly meeting, held September 6. During August the shipments totaled 18,254 carloads, as compared with 16,959 during August of last year. The July shipments were a little in excess of 2,000 carloads greater than those of the same month last year.

At the same time that the traffic committee of the Chamber reported this evidence of prosperity, it also stated that in spite of an increase of 10,000 in the number of automobile freight cars, various factories were still unable to secure cars when they were needed, and had entered complaints against the railroads. In the endeavor to secure all possible light upon the situation, the traffic managers of the various factories met in Detroit recently, with J. S. Marvin, traffic manager of the Chamber.

The good roads committee reported through its chairman that a movement has been started to encourage the universities and colleges of the country to establish courses in highway engineering, with a view toward providing the country with a body of engineers capable of taking charge of road construction work.

The committee found, by inquiry among the various state highway commission, that there was a decided shortage of suitable engineers, severe enough to hamper roads construction. Nearly all the commissions stated that preference would be given college graduates in making engineering appointments.

A census of 75 colleges and educational institutions showed less than half providing for any specialization at all in highway subjects, and only four have special courses leading to degrees or certificates in highway engineering.

The Chamber voted to accept an invitation to affiliate with the Chamber of Commerce of the United States, which has its headquarters in Washington, D. C., and is of considerable influence in trade matters.

Beside the routine matters, other subjects were considered, not the least of which was the rim situation, which was not permitted to languish without attention. It is violating no confidence to state that while no official action was taken, at least the promise of new angles was sufficient to attract much notice in informal discussion participated in by various heads of the industry.

Electric Vehicles at Electrical Exposition

Electric passenger and commercial vehicles, as well as accessories, will hold a prominent place in the New York Electrical Exposition at Grand Central Palace, October 11 to 21. A test run is now being planned to be held during the exposition. The Electric Garage, of New York City, will have an exhibit representative of the work it is carrying on. Among the pleasure vehicles will be the Baker, R. & L. and Detroit cars. Among the exhibitors of commercial cars will be the General Vehicle Co., Walker Vehicle Co. and Ward Motor Vehicle Co. The Edison Storage Battery Co. and the Electric Storage Battery Co. will have exhibits.

Death of Thornton Hopkins

Thornton Hopkins, connected with Beckwith-Chandler Co., varnish makers, for many years as a representative

in their railway department, and subsequently as assistant secretary, died at his late residence, Fort Hamilton, Brooklyn, N. Y., on Monday, July 31, at the age of 50.

Mr. Hopkins was born at Fort Hamilton. He was the son of Francis Hopkins and Rebecca H. Sears, both belonging to old New York families, Francis Hopkins having been born nearly 100 years ago, just where the tower of the Produce Exchange now stands in New York.

For several years he was a clerk in the employ of C. T. Reynolds, and when that firm consolidated under the name of Devoe & Reynolds continued in their employ. In 1906 he severed his connection with them and accepted a position with Beckwith-Chandler Co., remaining with them until his death, although for the past year or more he had been incapacitated from active duties on account of ill health.

Mr. Hopkins had a wide circle of friends. At the various railway conventions, which he regularly attended up to the time of his illness, he will be sadly missed.

J. N. Chamberlin, for many years connected with Beckwith-Chandler Co., has been looking after Mr. Hopkins' trade during the latter's illness, and will continue to do so.

Pennsy Lines Will Aid Detroit Shipping

Extension of the lines of the Pennsylvania Railroad into Detroit is being planned, and when completed will have an exceedingly important effect in increasing the city's freight facilities. At present, raw materials from the east, which are shipped from Pittsburgh to the automobile plants in large volume, have to go through Toledo, where there is such congestion as to delay shipments materially. The Pennsylvania tracks will avoid this.

The track will enter the city by the west side of the city, where ground for a terminal has been secured. This is the part of the city that has shown the greatest building activity, and the confirmation of the Pennsy rumor will give still more impetus to local companies. The Saxon Motor Car Co., Springfield Body Co. and the Detroit Seamless Steel Tube Co. are three of the latest companies to decide on building new plants on the west side.

Packard Gets Grand Prize

H. H. Hills, sales manager, of the Packard Motor Car Co., Detroit, Mich., is very proud of the grand prize and highest award for motor cars and trucks exhibited at the Panama-Pacific International Exposition, which is set up in his office in the center of a great banner of purple silk and gold.

He also has a letter from O. H. Fernbach, secretary of the International Award Systems, which says in part: "Beg to inform you that the award to the Packard Motor Car Co. as adjusted, of grand prize on motor vehicles naturally goes to the merit of the products exhibited. The grand prizes does not mean merely a grand prize on the exhibit, but it means a grand prize on motor vehicles, which includes motor cars and trucks."

Harvey Spring Plant Addition

The Harvey Spring & Forging Co., Racine Junction, Wis., has broken ground for a new fireproof building, 100 x 200 ft. It will be used for forming and heat treating automobile springs, made necessary by the growing demand for the company's boltless type of spring.

An English Three-Wheeled Car of Original Design

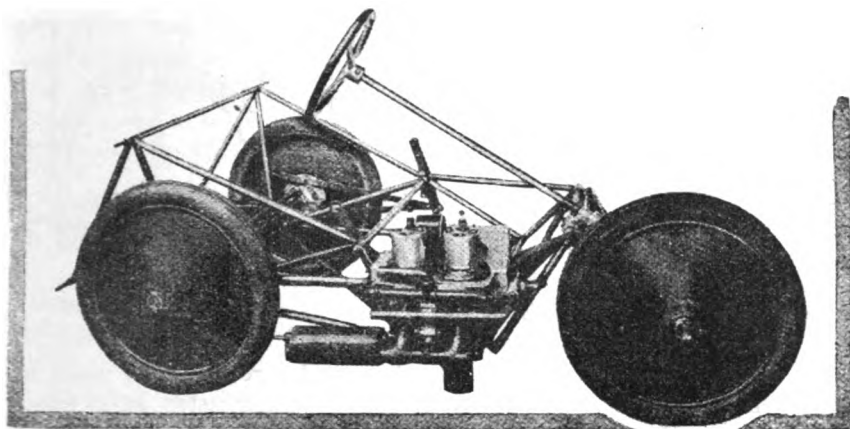

The chassis of the new Scott three-wheeler. The triangular construction is clearly seen

A "betwixt and between" vehicle, which is neither side-car nor light car, and which contains many new and novel features, has been put on the market in England. It is the invention of Albert Scott. The arrangement is on the somewhat familiar lines of any ordinary side-car outfit and was first designed as a machine gun carriage, for which purpose it possesses the peculiar advantages of the side-car outfit, while its design eliminates many of the weaknesses of the latter.

The following description along with the illustrations are taken from the Light Car, of London.

In order that it may be clearly understood why the three-wheel design was decided upon in preference to the more conventional four-wheel design, it is necessary to point out the distinct advantages of the side-car over the four-wheeler for such work as the mounting of a machine gun.

Advantages of Three-wheel Design

In the first place, the side-car outfit is light, speedy, occupies very little room on the road, and, what is most important of all, requires very little space in which to turn. It can, indeed, be turned in a circle, with the side-car wheel as the axis, this point being made quite clear in the sketch showing in plain view the positions occupied by the wheels of a side car outfit, a tricycle, and car respectively. A shows the angle of the front wheel of side-car outfit or the new Scott when the vehicle is turning, with the side-car wheel as a stationary pivot. Now, if the front wheel were placed in the center, tricycle fashion, the front wheel would have to attain the lock shown at B for the machine to turn in the same compass, and if it were a four-wheeled vehicle the left-hand front wheel would have to attain the obviously impossible position shown at C.

Triangular Construction

Another great advantage of the three-wheel design is that it lends itself to a triangular framework, and a triangular framework is mechanically superior to a rectangular framework, because a rectangle needs to be braced, whereas a triangle is braced in itself. A rectangle can be distorted to a rhomboid with comparatively little effort, and to prevent this distortion it would be necessary to brace the frame so as to convert it into one of interconnected triangle construction. A triangle, on the other hand, cannot be distorted unless one tube be actually lengthened and another shortened, which

may reasonably be regarded as impossible.

The frame of the Scott car consists of a number of eye-headed tube lengths assembled to form a series of interconnected triangles, and the frame is so designed that the tubes are subjected only to direct tension or compression. None of the tubes is subjected to intermediate bending stresses, and thus it is possible to obtain maximum strength for a given weight; while crystallization of the tubes, usually brought on by side strains, is not so likely to occur.

Only one size of tubing (1 in.) is used in the construction of the frame, and in case of accident any member can be withdrawn and replaced by a telescopic spare tube.

The employment of eye-headed tubes does away with all brazed junction lugs, with their usual weaknesses and the difficulties they add in the assembling of the frame. Nut and bolt fastenings take their place and after long and severe practical test it is found that the frame joints show no tendency to work loose.

One Wheel Drive

From the 5 h.p. two-stroke engine (3 x 2.5 in.) the drive is transmitted through a three-speed gear box by enclosed propeller shaft to the back wheel bevels, one wheel only

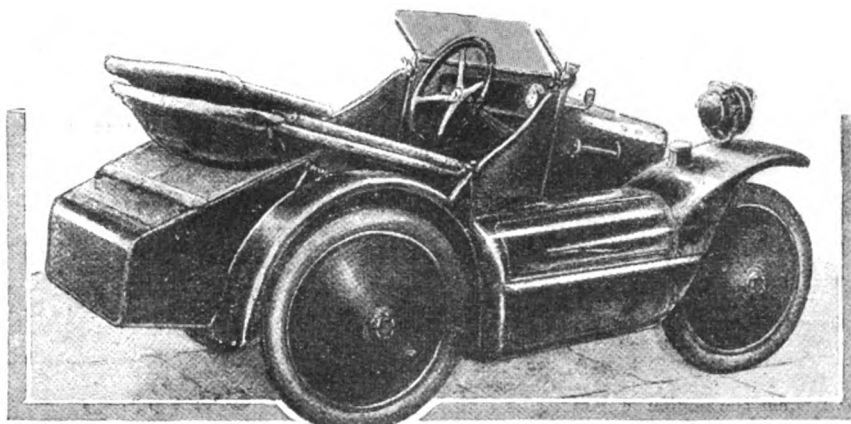

Three-quarter rear view of the new Scott three-wheeler car

being driven. It may be contended that the design lends itself to a two-wheel drive, but it was found that the disadvantages of the latter system, especially as regards cost of production, far outweighed its possible advantage. One great advantage of the one-wheel drive is that it allows all wheels to be splayed, which gives greater strength and improved tire wear, while its disadvantages are reduced by

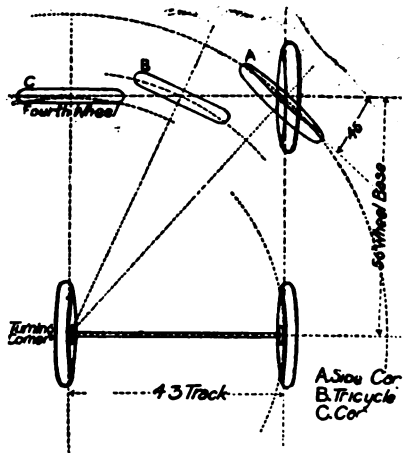

Comparison of the steering of the Scott three-wheeler and car respectively, showing the advantage of the first

the inclusion of instantly detachable and interchangeable wheels, so that uneven wear of tires can be prevented by simply changing round the wheels. The springing system is based on the use of coil springs, which are cheaper, lighter, and allow a wider range of action than laminated springs. The rear springing is effected on the bell crank lever system, which allows a very extravagant motion to the body. There are two pairs of springs to each wheel. The axle of the front wheel is mounted at the apex of a triangular structure, which is pivoted at its base to the main frame, the position of the springs being shown in an illustration. This arrangement gives immense lateral strength, while slack in the pivot bearings cannot cause rattle or interfere in any way with the steering, the bearings being in constant thrust.

Both brakes are Ferodo lined, internal expanding. The foot brake operates on the off side wheel, the hand brake on the driving wheel. Under normal conditions the foot brake is used, and its effect is counterbalanced by the retarding effect of the idle engine on the rear wheel. If the foot brake operated on both rear wheels, the driving wheel, it will be realized, would do more than its share in retarding the speed of the car unless the clutch were disengaged, for, in addition to the influence exerted by the brake, it would be called upon to pull round the idle engine, which acts as a brake in itself.

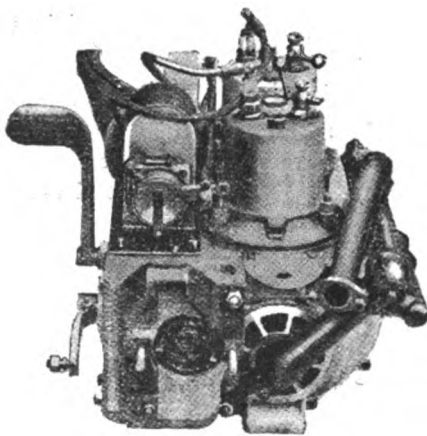

End view of the power plant

The Chassis
The weight of this outfit, fully loaded, is between 500 and 600 pounds, or approximately half that of the alternative four-wheeler. The chassis may appear to consist of an unnecessary number of tubes, but in point of fact there is no superfluous tube in its whole construction, and, since the tubes are subjected to no bending stresses, they are of comparatively small dimensions. The framework, indeed, weighs less than that of

a motor cycle and side-car, while, owing to its correct design, it is infinitely stronger.

In order to obtain proper distribution of weight, the engine must lie midway between the steering and driving wheels, and this has led to a mode of construction by which the engine is offset from the frame, and therefore in the most accessible position. An offset position may appear insecure, and so it unquestionably would be were it not that the three-point or triangular method of construction, applied throughout the design of the machine, has been followed with regard to the engine attachments. That the engine attachment is good is evidenced by the fact that very little vibration exists about the framework even when the engine is running at high speeds. If it were incorrectly secured vibration would be apparent.

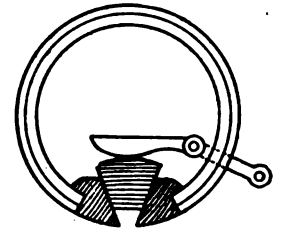

Detail of the brake mechanism

Steering

Steering is by gear pinions contained in an aluminum box, and care has been taken to ensure the peculiar advantages of the castor wheel effect of motor cycle steering. From one of the diagrams it will be noticed that the steering wheel "meets the road" in the act of cornering in the case of the Scott car, whereas the steering wheels of a four-wheeler always remain vertical, or nearly so.

Since coil springs are used, the back axle is deprived of the usual attachment to the frame afforded by laminated springs, and therefore provision must be made to retain side movement. This is done by the inclusion of a third radius rod, which lies across the frame, being attached to the bevel box at one end and to a lug on the frame, near the side-car wheel, at the other. This rod, therefore, resists those side movements which are usually resisted by the laminated springs of ordinary light car construction.

The tube enclosing the propeller shaft acts as a radius rod on the engine side, while its fellow, of equal length, occupies no unusual position on the opposite side of the chassis.

Power Unit—Rotary Inlet Valve

The engine, which is, of course, of the two-stroke variety, is rated at 5 h.p., and its high efficiency can be largely attributed to the use of the rotary inlet valves. These valves are contained in the crank case doors, and are driven by pin projections from the respective cranks.

The valve consists of a case-hardened steel sleeve, which rotates on a hollow phosphor bronze boss, the charge being drawn from the interior of this boss. Both the sleeve and the boss contain ports, so that, as the sleeve rotates, these ports come opposite each other at a given point in the revolution, thereby allowing the charge to pass into the crank case. The boss on which the sleeve rotates may, therefore, be regarded as a dead end to the induction pipe until the two ports are opposite, and at that juncture the crank case is drawing its charge to be next exploded in the engine. By this system it is possible to introduce to the engine a more complete charge than would be possible

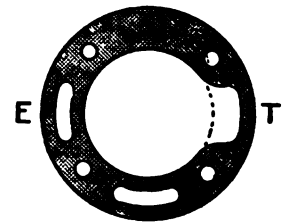

The flange face on which the cylinder beds. E, exhaust. T, transfer. W, water

if the induction were governed by a port uncovered by the piston, while the latter system necessitates weakening the cylinder by the inclusion of three ports—inlet, transfer, and exhaust.

Water Cooling

The water jackets consist of aluminum sleeves which slide over the machined cylinders, and are held down thereto by the nipples which take the sparking plugs and compression taps. No decompressor is fitted. The jackets face down at their base on to rubber washers, which allow for unequal expansion between the jackets and the cylinders.

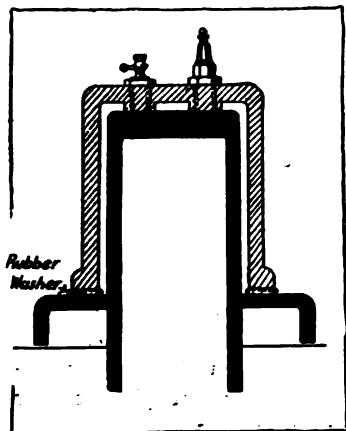

How the aluminum water jacket is applied to the cylinders of the Scott engine

Cooling is assisted by a centrifugal pump, mounted at the end of the auxiliary shaft.

It will be seen from our photograph that the cylinders present a remarkably clean appearance. One is at first at a loss to realize why, but closer scrutiny reveals the fact that the effect is produced by the absence of induction pipes and exhaust connections, while there is but one water connection direct to the cylinders.

The simple process of tightening down the cylinder makes all joints excepting the top water connection. The cylinders bed down on to a wide flange, and through this flange pass the necessary supplies upon which the engine is dependent. That is to say, that the charge of gas which is drawn into the crank case passes to the cylinders by channels which pass through the cylinder and crank case joint. Water is in the same way conducted to a channel in the aluminum casting of the crank case, whence it passes to the cylinder via the wide joint, which is tightened up by the cylinder security bolts. The exhaust passes from the cylinders into separate channels in the crank case, and the silencer pipe connections are direct from the latter. Thus, the important joints are brought home by the necessary function of tightening down the cylinders, there being no small joints, which are usually insecure and a source of irritation to contend with.

The petrol system of lubrication has been adopted.

Transmission

The transmission from the engine to the gear box is by a 10 deg. spiral drive, giving a one-third reduction. The gear box is integral with the crank case, and the general layout of the drive is shown in one of the diagrams. The clutch is contained in the flywheel, on either side of which are skew cut pinions. One of these pinions is attached directly to the flywheel always, and drives the auxiliary shaft, on which the engine starter operates, and which drives the water pump. The magneto also is driven by this wheel. The pinion on the other side of the flywheel rotates only when the clutch is engaged, and this pinion

conveys the drive to the gear box and thence to the road wheel. The gear box contains a simple and practically frictionless universal joint, so that the whole system of transmission is positively enclosed.

The clutch mechanism is such that the clutch cannot be engaged until the gears are properly home. In the same way, it is impossible to move the gear change lever until the clutch is disengaged, so that the gear is rendered practically foolproof.

The clutch is the result of experiment aimed at producing a clutch that requires absolutely no attention, and which, therefore, can be placed in such a position that it cannot be easily tampered with. Its design is distinctly novel, and it would appear to be a highly efficient mechanism. For the sake of clearness, it may be likened to an ordinary leather-faced cone clutch, except that, in place of the leather cone, a split steel ring lies between the male and female members. Both the latter members are secured to the engine shaft, and it is this split steel ring, lying between them, that takes up the drive. With the clutch disengaged, the ring is free to rotate independently of the engine, but as engagement takes place it is firmly gripped between the inner and outer members, thus taking up the drive.

The action of the clutch is as follows: As the clutch

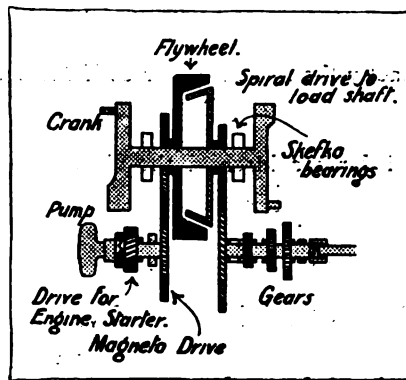

Layout of the transmission system of the new Scott three-wheeler

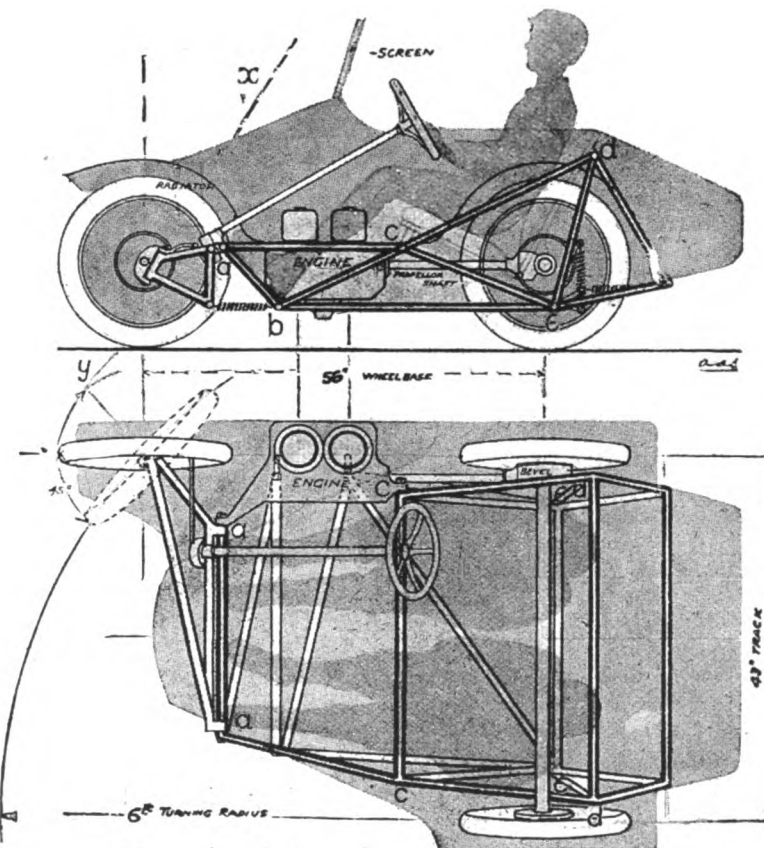

Chassis Scott car

is gently insinuated, the inner member comes into contact with the steel ring, and the drive is thus taken up in exactly the same manner as if the clutch were of the ordinary cone variety. The steel ring being split, however, the drive is taken up very gradually, and as the clutch is still further inserted the ring slowly opens, until finally it begins to bind on the outer member of the clutch. It is now being driven by both members, and when fully home the drive is positive.

Price of White Lead

The following circular was recently sent out by the National Lead Co.:

"The advance in pig lead early this year was so rapid and brought the price to so high a point that buyers of all lead products have naturally been in doubt as to how far they could safely make sales or contracts for the future, or to what extent they could, with safety, stock up at present prices.

"Pig lead is subject to many influences growing out of the European war and Mexican situation, and no one can tell with any accuracy what the course of prices will be. It is reasonable to expect, however, that so long as the war continues and this country remains the chief source of the world's supply of lead, the market value will be considerably above the level which prevailed before 1915, though there is no apparent reason for believing that it will be higher, for any length of time, than it has been since the middle of March.

"The advance in white lead has not at any time since the war began equaled the advance in the cost of the materials from which it is made, and it is fair to assume that following this conservative policy, corrodors will make no further advances unless they are forced to do so as a matter of self protection against a much greater rise in pig lead than now seems probable.

"On the other hand, knowing how badly trade is disturbed by frequent price changes, it is not likely that they will reduce their prices, following any decline that may occur in pig lead or other materials, until there is some assurance that the decline is permanent.

"For these reasons it seems to us that while there is nothing in the present situation to encourage buyers to speculate on the prospect of higher prices, there is also nothing which should cause them to hesitate to purchase as freely for their probable requirements at this season of the year, as they would do on a lower basis of prices.

"We make these statements in answer to many inquiries direct and through our salesmen, from dealers who wish to feel safe in carrying enough stock to supply promptly any demand from their customers."

Studebakers to Spend \$1,500,000 on Plant

The Studebaker Corporation, South Bend, Ind., announces that it has let a contract for the erection of a modern foundry and large machine shop on part of the site occupied by the lumber yards of the corporation. The cost of the improvements is estimated at \$1,500,000.

It is the expectation of the management that when the new plant facilities are completed the average number of employes of the South Bend works will be increased 20 per cent, or 1,000 men, consisting chiefly of skilled mechanics.

According to the announcement, the machine shop will

be about 900 feet long by 300 feet wide, and will supply twice the facilities of the shop now in use. The new foundry will be 1,100 feet long by 150 feet wide. It will have four cupolas and a daily melting capacity of 250 tons. This building will be ready for occupancy by July 1, 1917.

The Popular Light Car

Although the cyclecar was a fizzle, as was anticipated by everyone acquainted with motor mechanics and road conditions, says Scientific American, there is an undoubted demand for a small car that is reasonably light in weight and moderate in power, combined with as complete simplicity as is compatible with convenience and efficiency. The people who want such a car are not merely those who cannot afford anything larger, but there are many owners of big, high-powered cars who realize that it is not reasonable to wear out a big car that is costly to buy and expensive to operate on trivial errands that can be much better and more conveniently done with the smaller machine; and this demand will increase as people get over the habit of buying a new car every year.

Dayton Malleable Iron Co. Changes Its Lines

The Dayton Malleable Iron Co. has retired permanently from the manufacture of carriage hardware and fifth wheels. Orders already accepted will be filled as promptly as possible. This action has been made necessary by increased business along other lines. The company recently purchased and equipped a branch foundry at Ironton, O. In addition to making a general line of malleable castings under contract, they will carry in stock such specialty lines as Sarven wheel flanges, concrete construction specialties and specialties for railway use.

Chevrolet \$490 Electrically Equipped

The Chevrolet Motor Co., New York City, has raised the price of its Baby Grand model from \$750 to \$800 and also announces that hereafter the price of \$490 for its small model, known as the Four-Ninety, will include electric light equipment and electric self-starter. Heretofore, the Four-Ninety model equipped with electric lights and starter sold at \$550.

Pending the completion of a new assembling shop and a new motor repair shop by the Falls Motor Corporation, Sheboygan Falls, Wis., a large part of the final processes of the manufacture of gasoline motors for automobile purposes is being carried on under canvas. A huge tent has been erected on vacant property adjoining the plant so that assembling work may go on without interference of delivery schedules. The company has been able to procure 35 to 40 skilled machinists from other metal-working centers, but is in need of a great many more men.

The Armored Motor Car Co., Detroit, has been incorporated at \$100,000 capitalization by Harry W. Frost, 50 West Kirby street, Detroit; Waldo S. Ross, 623 South Main street, Sioux Falls, S. D.; Webb C. Artz, 50 West Kirby street, Detroit, and A. Lester Mancourt, 720 Jefferson avenue, Detroit. The object of the new company is the manufacture and sale of armored motor cars and devices accessory to them.

Economy of the Semi-Floating Axle

By A. M. Laycock

During the last few years the semi-floating axle has become very popular, not only in the passenger car field but in motor truck service as well, even up to five tons capacity.

However, there are still people who have very decided views as to the relative merits of the semi, three-quarter and full-floating rear axle. Perhaps it has never occurred to most readers that the tonnage of the world is carried on semi-floating axles.

All railway rolling stock, including locomotive, freight car and passenger coaches are operating on semi-floating axles. If we should substitute the term "fixed hub" for semi-floating, as one of the axle manufacturers has lately announced, it might be better understood applied to railroad work, as all heavy rolling stock has the wheels keyed or fixed to the axle. In all railroad designs, the dead weight of the vehicle is carried on the axle itself, and the torsion as well; while every one can realize at a glance that the dead weight is carried on the axle, it is not so easy to grasp that there is a considerable torsion also.

On large European railroad engines, using inside and outside cylinders, it is quite easy to realize that torsion is present in the driving axle, and even with the conventional engine, using two outside cylinders; but with the passenger and freight cars, it is difficult to appreciate that considerable twisting takes place on the axle, but on rounding sharp curves when the outer wheel is running on a larger radius than the inner, the twisting moment in the axle is equal to the total weight carried multiplied by the radius of the wheel and the coefficient of friction on the rails which, when figured, amounts to a considerable torsional stress in the axle—in fact, absolutely in the same proportion to the twisting moment in the semi-floating five-ton worm drive axle, as this is figured in the same way, particularly when propeller shaft brakes are used.

Advantage in Widely Spaced Bearings

Taking for granted that we have the combined bending and torsion in the axle with a fixed hub, the outstanding feature in favor of this construction for real heavy duty, lies in the fact that bearings are spread so very far apart—in fact, on most passenger and freight cars the bearings are on the outside of the wheel, and in European locomotive practice, with inside cranks, the bearings are always on the outside, while on the tender of the engine they are generally spread as far apart as possible. This, of course, greatly enhances the life of the bearings, as the unit pressures are so much lower, particularly when rounding curves when bearing pressures are maximum. It would be interesting to note what would happen to a full-floating axle taking curves regularly at 35 m.p.h. under these extremely heavy loads. We prophesy that the train officials would have an anxious time between hot boxes and time schedules.

Contrasting this heavy design with the full-floating type, where the bearings are spaced 4 to 6 in. apart as against 64 in. in freight car service, considering that the wheels are approximately 33 in. diameter, as against 36 to 40 in. on the motor truck and that the freight car is operating on a perfectly smooth road bed, whereas the automobile is subjected to direct violent blows on the tires due to rough roads but suffers very much more from the side

blows delivered at the rim of the wheel when swaying back and forth in deep ruts over country roads, and always having in mind that the designer's chief aim in motor truck axle design is to take care of these tremendous reactions from side skidding, curb work, etc., it is difficult to appreciate the reasons for the automobile truck designer following the full-floating construction, where the centers on which the reactions are taken are so very close together, contrasting so widely with the semi-floating design—in fact, the difference in these designs is so radical that it is hard to conceive of both of them being on right principles. Even forgetting principles for the moment, there is such a weight of precedent in favor of the semi-floating that the writer can only come to the conclusion that the full-floating is only used on account of the accessibility of the driveshafts. If the full-floating construction had been adopted by railroad engineers for the same reasons, people who knew these facts would have a very creepy feeling when taking any long journey by rail.

We prophesy before very long that advertising men in the automobile field will not boost the full-floating axle on account of its accessibility, when driveshaft failures

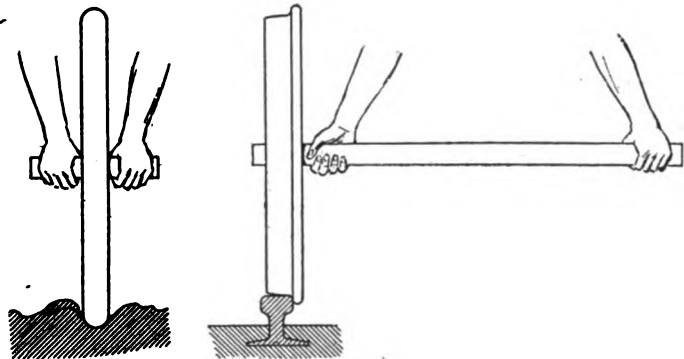

Illustrating full and semi-floating arrangement

take place. It is infinitely better to put a driveshaft in there that will not break. This is the least that one can expect with our present knowledge of alloy steels and their proper heat treatment.

Full-Floating Impossible on Locomotive

Imagine locomotive designers starting out to design a full-floating axle for the locomotive itself, particularly on the main drivers. It would be considered by railroad engineers a practical impossibility. The bearings would be so large that there would be no spoke left in order to take care of the reactions when rounding curves, always having in mind that a choice of bearings is made from the side pressures at the rim of the wheel and not the straight static loads on the axle.

The illustration here shown is quite well known but clearly outlines the relative merits of each. The one with outstretched arms representing locomotive or semi-floating axle construction while the other represents full-floating or wagon practice.

Taking for granted that the locomotive, passenger and freight cars are all of the semi-floating or fixed hub construction and that the full-floating is horse-drawn practice (so far as its capacity for taking curves is concerned) should the motor truck builder follow locomotive practice or revert to horse-drawn design? This is no reflection on the carriage axle—the present form of axle serves its

purpose well for horse-drawn work, but this design should never do for real heavy haulage where speed is a consideration.

Again, on locomotive design the unsprung weight is really not a consideration on account of the very slight spring deflection due to the excellent condition of the road bed, but where such large unsprung weights have to be used as in modern worm drive axles, it is very much more essential that the semi-floating axles be used on trucks than in locomotive practice, as one of the principal items in the maintenance cost of heavy motor trucks is the tires consumed.

One of the most wonderful designs in the pleasure car world, noted for its exceptional gasoline economy and big tire mileage, attributes some of its success very largely to the semi-floating axle, full-elliptic springs and the Hotchkiss drive, particular attention being paid to reduction of weight at the wheel hubs themselves, even carrying this out as far as the rim and dispensing with the conventional demountable rim in favor of the fixed one in order to save weight where it is most detrimental.

Motor truck users who have had experience or even know of the above machine will expect the same relative tire mileages from their trucks and will certainly demand the lightest possible weight at the wheels on any axle equipment, even going so far as to condemn heavy cast malleable brake shoes and their attendant two-point contact, necessitating much heavier flanged and reinforced brake drums than are required with the self-intensifying band type of brake.

If all these considerations are being made in the pleasure car field, we prophesy that before long motor truck users will demand the same attention to details for economy of operation which has characterized the endeavor behind this design for the last nine years.—Automobile.

Meeting of M. & A. M. Directors

Directors of the Motor and Accessory Manufacturers held their monthly meeting on September 8 at the offices in New York City and elected four new members. They are: Dann Products Co., Chicago; Master Carburetor Corporation, Detroit; Otis Elevator Co., New York City; Parry Mfg. Co., Indianapolis, Ind.

At the same time it was reported that literature and application blanks for space at the New York and Chicago shows was being mailed to members. The M. & A. M. has charge of the parts and accessories space at both shows.

There is no prospect of there being any change in the attitude toward the Boston show, which, while almost universally considered a part of the national show circuit, is not actually in that standing as it is not conducted under sanction from the National Automobile Chamber of Commerce and the M. & A. M., and therefore must be participated in by dealers, instead of manufacturers.

Electrics for Bergen, Norway

Automobile dealers in Bergen, Norway, are becoming interested in the possibility of introducing electric cars and truck there. The head of one firm recently sent his brother to the United States to arrange for the representation of electric vehicles in Bergen. A cheap supply of current is available.

Bergen is very hilly, with average grades of 10 per cent,

the roads are narrow and not very good and travel is interrupted by fjords and arms of the sea, which cut into the coast. But notwithstanding the American consul reports that the use of electrics is believed to be feasible and that the business people are interested in these vehicles.

S. A. E. Winter Meeting Plans

The annual mid-winter meeting of the society will be held during the week of the New York Automobile Show. This year the show will begin a week later than formerly so that the holidays will not be molested as they have been for years past. The show week commences Saturday, January 6 and ends January 13, the following Saturday night.

The annual S. A. E. dinner, the social feature of the week, will be held at the Hotel Biltmore on Thursday evening, January 11. The grand ball room, with capacity for 750 guests, has been selected because in connection with this hall there are large reception halls that have adequate accommodation for the society members. In view of this ample assembly space there will be more of a reception and get-together session of members before the dinner than heretofore.

Thursday will be devoted to professional papers and discussion of automobile subjects. The session will start at about 10 a. m., the official morning opening hour during the New York show week, and the work will be over at 4 p. m. At noon a buffet luncheon will be served. This session will be held in the large assembly room of the Engineering Societies Building, 29 West 39th street, on the sixth floor, on which the society offices are located.

Although Thursday will be the big day, the work of the meeting will start Tuesday when the standards committee will hold a session and add finishing touches to the reports of its various divisions.

The usual business session will be held Wednesday to consider reports on membership, from the treasurer and tellers of election, and for the discussion of proposed constitutional amendments and new business. After a short business session various reports of the standards committee will be presented for approval. Wednesday afternoon will be given over largely to consideration of aviation subjects. It is also planned that there shall be at least two important papers on aeronautics, to be followed by three fifteen-minute discussions of important aviation subjects.

Motor Trucks in Austria

Several large concerns in Austria are planning to manufacture heavy motor trucks, as the machines have been subjected to extreme tests in army service during the war and have proven to have great serviceability. Two concerns that are making ready to take manufacturing when the war is over, are the Skodawerke A. G. of Pilsen and the Waffenfabrik at Steyr. When starting these companies will require machinery and machine tools with which to equip their factories.

Schwarz Wheel Co. Enlarges

The Schwarz Wheel Co., Philadelphia, Pa., has purchased six acres at Holmesburg, near its present plant, for extensions.

Paint Shop

Automobile Paint Shop Information

In repairing automobiles it is often necessary, as a matter of curtailing expenses, to make one coat of color serve the purpose of two, and in order to successfully accomplish this venture resort must be had to the use of heavier coats of material, or to coats of the most opaque pigments. The transparent pigments, so-called, cannot very well be used for one-coat work, and when it is desirable to approximate the effects of these transparent colors, about the best that may be hoped for is a color cast to the shade of the transparent article, but holding to the solidity and the covering capacity of the commoner pigment.

It was formerly the case that no intermediate quality existed in the field of the lake pigments and all the effects were obtained through the use of glazing processes, but manufacturers, during these latter years, have recognized the need of lakes with much of the brilliancy of the old time materials and the added advantage of greatly increased covering capacity, which, at a reduced cost, may be employed to produce a job that will wear and do splendid service. When, therefore, the call comes, as it is sure to come, for a one-coat job flashing the shimmer of some glorious lake, the thing to do is to get the surface in shape, cutting away the nibs and knots of dirt and otherwise dressing the old fabric down to a smooth and neat condition and then seek, by the aid of a simple preparation coat, to fit the surface to receive a single coat of color in a manner to satisfy the car owner. This coat had best not be a flat or "dead" affair; rather should it be flowed on with enough varnish in its composition to give it the lustre of the traditional eggshell, but no more, and then, above this, fetch out the richness to deceive the very elect. It is not expected, of course, that a lake of this class will show the depth and the riches of the rare and expensive sorts, but for emergency cases, and for cheap work to wear for a time and look princely, it will do what many painters have long hoped for.

Black Breaks Monotony of Single Color Job

Something to help out the effect in this type of work can be done by running some lines of contrasting color about the surface, and tricking the moldings, if any, out in a coat of solemn black. Without robbing the surface of its attractiveness, black breaks up the monotony of a single-color job about the most effectively of any color. Indeed, it is a natural decorative pigment of surpassing dignity and with a dressiness quite the equal of any.

In the event of using a coat of rubbing varnish over the color coat, when striping is omitted, it is good policy to use some of the color in the varnish, both to preserve the purity of the color and to enrich the field prospect. Another help when working for a quick and cheap job is to encourage a selection of some neutral color, such as dark gray, or medium deep brown, or a deep, rich red, which can be built up at the expenditure of two coats of pigment, or three, at most, and the surface developed into

a fine state of color effect. Gray, of two or three shades, makes a most excellent pigment for moderate priced jobs, and gives, on the whole, great durability, with the added advantage of being an easily cared for color and showing the ravages of service less than most pigments.

Browns Can Be Embellished With Telling Effect

The browns are colors which have many merits for work which must be brought along at little expense, and with some black and imitation gold lines, cast in pairs around the edge of the panels, the ornamental feature will show off with telling effect. There are at present some light blues which cover solidly at one coat, and these colors may be handled with fine results on cheap work. Just put under them a coat of light brown or one of lamp-black, to hold them forth at their full strength, and then cast a line of black and one of Arctic white or silver white across the most appropriate spaces, and the result is certain to be worth a second look.

In fetching up these cheap surfaces have a care that all defects are well taken in hand and puttied, and then dressed down to match the surface about them. The main thing is to bring the surface up to the point of coloring without a blemish. When the surface disfigurements have to be brought down on the final color coat, it means an added expense, with the chance that they may not be entirely obliterated. The only right way is to break up all such defects prior to the application of the color and to make the surface good and perfect. After the color there is then little to do in addition to applying the regular coats of material, and the finish will look complete.

For this cheap class of work a good, heavy bodied varnish is the best, for obvious reasons. And in finishing such work the surface should be given all the varnish it will accommodate and take care of. In this manner it will have the protection which it needs, together with the increased body and lustre afforded by the larger and deeper flow of varnish.

Monograms a Wonderful Help

If one is expert in putting on monograms, simple styles of these ornaments will do much to lead the eye away from the lack of refinement of the finish. The ornament, while small, is a wonderful help in relieving the sense of sameness. As the lamented A. F. Manchester used to say: "That little patch of color warms up the entire job." And especially the class of jobs here referred to. In designing the monogram the initial of the surname is to be invariably made more prominent than the letters of the Christian name, and this initial will therefore need to be painted in stronger color effects than the succeeding letters. It is to be understood, of course, that the colors used in striping are in a sense to govern the colors of the monogram, but this is no longer rigidly adhered to. Upon these old jobs, at any rate, where the employment of the monogram is made to serve a utility purpose quite as much as a feature of decoration, the choice of colors need not be determined by the striping pigments, although

they should harmonize with the surface color. At all events, there are no arbitrary laws to govern the scheme of color selected.

A novelty in contrasts is shown by applying the monogram entirely in gold, or imitation of gold, and then glazing the first letter with ultramarine blue, the next with verdigris, and the third with carmine. Another effect may be obtained by painting the letter in vermilion, then glazing with carmine, shading the carmine with asphaltum, and finally high lighting with pale canary color. An ornament of this kind will make the chronic grumbler forget his troubles. In designing a monogram the size of the panel or space in which the design is to go should not be ignored; this is more essential than choice of colors for the design.

Mind the Little Details

In getting out these cheap jobs of painting as a means of meeting the demands of all sorts and conditions of car owners, it is good business to send the car out with all the little details attended to. These may not, at the time, appear to count for much, but in the long run they serve strong advertising purposes and help to bring in a better paying class of trade.

Edges of fenders, bolt heads, under parts of the car, the top, etc., all need a careful inspection, and an equally careful touching up with the right color, to bring everything out prim and fine. Perhaps the top will need attention. If a rubber one, it will require sponging off with tepid water in which a wisp of castile soap is allowed to float, with a thin coat of dressing to follow. The leather top, if hand buffed, will scarcely need more than a sponging off with a weak solution of castile soap and water. The machine buffed one may be treated likewise until the grain of the leather begins to go raw, at which time a dressing of the same material suitable for the rubber fabric is in order. The mohair top will go very well with a simple brushing off with a whisk broom; in any event, never use any of the ordinary dressings, nor a solvent solution, for all such are absolutely ruinous to the fabric.

The vacuum cleaner is almost indispensable for removing dust and dirt and foreign accumulations from the upholstery and from the interior of the car generally, and this work needs to be performed prior to the painting operations. Then, when the finish is complete, a light cleaning out will suffice to put the interior in a condition to well correspond to the other appointments.

Painter the Natural Man to Clean the Car

Recently a friend of the writer has been picking up a lot of business in cleaning up cars, this work being generally taken care of by the garage plants. In every town there are a number of car owners who are the very elect in motor car affairs, and these men find the painter, if conveniently located, the most agreeable man and the most reliable and the best prepared to handle the cleaning up of the car. A couple of finely cleaned and polished cars furnish taking advertising matter, and if the painter is prepared to take care of this class of work, he can generally, during the summer months, get all that he is able to do in connection with his regular work of repainting. Incidentally, this car cleaning will be the means of bringing in additional painting and varnishing repairs. Of all men, the painters should be best prepared to use the various cleaners and polishes now floating on the markets. Some of these mediums are positively ruinous to the varnish, some are slow death to the lustre, and some are

simply cleaners, offering no life-giving element to the finish. Therefore, with his practical experience the painter is in a position to make intelligent choice, after careful tests, of a cleaner that not only cleans but feeds the finish as well.

In the repainting processes above considered, the chassis should come in for thorough treatment, which they often fail to get. It is a temptation to hustle the painting of the chassis along without giving the coats enough time to dry thoroughly, or to defer work upon them until the body is practically finished, and then slighting the processes, or otherwise suiting the finish to the brevity of the time at disposal. We believe it to be economic practice combined with good business to make the finish on the chassis compare favorably with that on the body of the car, and this cannot be accomplished short of careful and complete surfacing and finishing processes. These parts of the car are exposed to a ruinous form of service; consequently, unless they are kept under a strong body of varnish, with a sure and fine foundation, supporting it, the appearance of the running parts is certain to be at all times inferior to that of the body.

The final coat of varnish should have ample time to dry before exposing it to a test of the elements, this applying to both body and chassis. A day or two of waiting for the finishing coat to shape up and grow mature and firm, will many times save some free after-treatment for the painter, and perhaps a dissatisfied customer, both of which are likely to prove expensive.

Choice of Chassis Colors

Choice of colors for the chassis is a matter that may very well have more attention bestowed upon it. Most any color will surely not do for these parts of the car unless the painter is prepared to make the best of a bad bargain, which a practice based upon this theory fails to lead to. The color for the chassis must conform in shade and tone to that on the body of the car. It ought never to be darker than the body; it may appropriately be several shades lighter, and, in fact, should always be somewhat lighter in order to give the effect of a strong support for the body and to set forth, in due order, the attractions of the body color. It can only do this when a lighter color, and one of no small distinction, is selected. Striping for the chassis is a feature which helps to relieve the color scheme, and to divert attention from any possible surface defects. Not much of this style of ornament, at this time, is needed, but a modest display executed by a master hand is the thing to be admired. The colors used to line the body surface are rightly due for the chassis.—M. C. Hillick, in *Painters' Magazine*.

Studebaker Cuts Overhead Costs

Three years of operation under modern efficiency methods at the factory of the Studebaker Corporation, Detroit, has brought enormous economic as well as mechanical improvements. While in 1913 there were 11,000 men producing 37,000 cars a year, there now are 7,000 men turning out cars at the rate of 100,000 a year. Due to the elimination of non-productive labor, overhead expense has been reduced 50 per cent. The reduction in the labor lost per car has brought the material cost to a higher percentage; material is now much the largest item in the building of the Studebaker, amounting to 70 per cent of the total.

A Plea for the Dash Radiator

Elegance and accessibility, says a contributor to Light Car, London, Eng., in his plea for sloping bonnets, are attributes conferred by the dash type of radiator, while it possesses practically no disadvantages.

If one were to consider seriously the reasons for the phenomenal success of the Renault cars, one would have to admit that some other reason than that of extreme reliability is to be found.

"Probably appearance, an elegant tout ensemble, has contributed largely to Messieurs Renault Freres' success," he says. "and this elegance must, I think, be largely due to the position of the radiator and the contour of the bonnet. When the designer of these cars placed the radiator immediately in front of the dashboard he knew what he was about. There are a very large number of reasons for this type of design and very few to be brought forward against it.

Some Alleged Drawbacks

"Let us first of all discuss the disadvantages, and, having given these due prominence, consider the benefits. The main disadvantage is weight, but later on it may be possible to show that this is not altogether an evil. Next, the presence of so much hot water near the dashboard may produce an unpleasant heat for the occupants of the car in warm weather. The answers to this are more than one. Has anyone who has had a considerable driving experience of Renault cars ever had real cause to complain on this score? The writer has driven cars of this marque over long distances both in England and France, and has never found the heat engendered any more oppressive than on cars of the usual radiator in front type. Even were it so, the art of the coach builder should be quite capable of providing adequate ventilation. And let it be remembered that really hot weather is extremely rare in these isles, and on the majority of days in the year the radiator will act as a very welcome warming device and be blessed for its presence. And how much more pleasant to sit behind hot water than behind oily and exhaust-created heat, as is, also, only too common on so many light cars, the dashboards of which only too frequently permit the passage of such vapors to the legs and nostrils of the driver and his companion. The fact of the matter is that the objections to the amidships radiator are not to be taken too seriously.

The Indisputable Advantages

"Now let us look at the other side of the medal. Anyone who has had to look after a Renault or a Bayard car, the two great protagonists of the sloping bonnet, will readily admit the extreme accessibility of the engine. This is entirely due to the sloping bonnet and the position of the radiator. No bending at an awkward and tiring angle over a dirty wing to get at the engine. Everything can be reached handily from the front, and backache avoided entirely. The engine is kept perfectly clean and free from flies, which find their way in scores through the more orthodox type of radiator and deposit their carcasses all over the engine. The magneto and carbureter possess a get-at-ability as remarkable as it is welcome. A very

expensive item of the car's anatomy is spared from damage in the event of a collision, which need only be slight to put the front radiator out of action. The weight of the radiator and water is carried in a far better position on the car so far as making the vehicle hold the road is concerned, and the front springs are largely relieved of unnecessary work, and can thus be made far more supple with less chance of a fracture.

"The light car makers who provide the dashboard radiator are chiefly confined to France, and are Renault, Charron, Hurtu, and Bayard, with a few lesser known firms. All motorists know that any design produced seriously by a French maker of repute has a good deal to commend it. Ever since the start of the motoring era Renault and Charron have been names to conjure with, and the success of their cars is sufficient evidence that this design is sound. In the writer's opinion it is excellent from the points of accessibility, comfort on the road, and appearance. Up to the present only the makers of the Siddeley-Deasy, Phoenix, and the Arrol-Johnston cars have stuck to this design in Great Britain. The G.P. Morgan Runabout is excluded, since it is scarcely a light car. It would

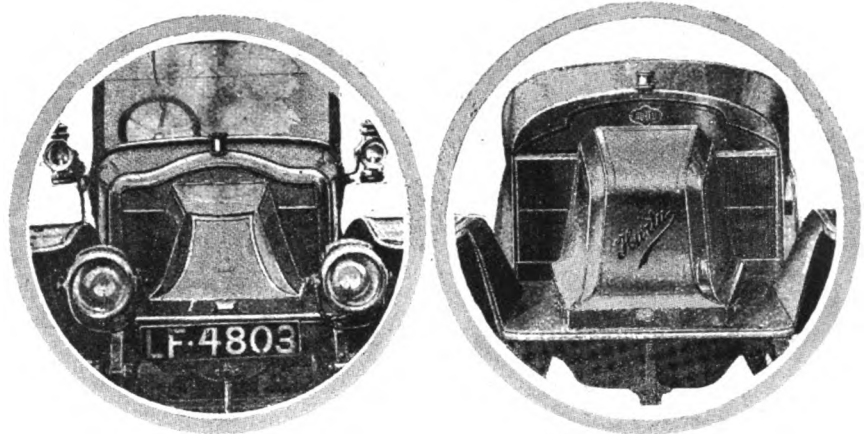

Two light cars with this radiator position are the Bayard and the Hurtu, the fore part of each being here shown

be interesting to know the reasons which induced these firms to adopt the backward radiator, and also to know the opinions of experienced light car owners on this matter."

Truck Club Annual Outing

The New York division of the Motor Truck Club of America gave itself up to a very pleasant fifth annual outing on September 13. The members and ladies took a delightful sail up and down Long Island Sound, disembarking at Glenwood Landing on the Long Island shore, where they dined and danced in the early evening and concluded with a moonlight sail home.

Repairs 85 Cents an Hour in Boston

Following a meeting of the board of directors of the Boston Automobile Dealers' Association, held recently, a uniform rate of 85 cents an hour for repair work will be charged in practically all of the service stations of the members.

A correspondent of the Scientific American predicts that the future motor car will be gearless and that it will be steam driven. "This is a prophecy and prediction," he says, "we are willing to put our money on."

Safety in the Forge Shop*

Most of us have seen picture illustrating the efforts of primeval man to fashion a weapon or a domestic utensil from metal. A large stone took the place of the modern anvil and a smaller stone served as a hammer. These with a nearby wood fire, constituted the equipment of the earliest recorded forge shops. The equipment of the forge shop of the present day differs only in the more perfect adaptation of the tools for the work in hand, and in the method of heating the metals. The principle of working the metals—namely, by pressure either intermittent as in hammer blows or constant as in hydraulic presses—is the same.

Although there are no records, it is fair to assume that primeval man was subject to what he might have considered annoyances in the form of burns and bruises. These same hazards are present in the forge shop of today and are accepted by the smiths as necessary evils. A piece of iron or steel may be hot enough to cause a painful burn and still have the appearance of cold metal, and burns caused by the smiths mistaking these hot pieces of metal for cold ones are very common. It is often a little inconvenient to get a pair of tongs before attempting to handle a piece of metal on the shop floor, but it is much safer to do so.

Another danger to which forge-shop men are subject is that of sparks flying from hot metal. When a smith takes a bar of iron or steel from the fire he almost always gives it a light tap on the anvil to knock off the oxide. Even with this precaution the first few blows of the hammer or sledge are likely to produce a shower of sparks, and a large spark of this kind, lodging in loose or ragged clothing, may burn the skin or even set fire to the clothing. This danger is so well recognized that, as a rule, smiths wear leather aprons which protect the body from the chest down. One of the inconsistencies in the forge shop lies in the fact that the eye is much more vulnerable than any other part of the body. There is probably no other organ of the human body so important or so necessary to the workmen, from the standpoint of either safety or efficiency. A single spark may be sufficient to destroy the sight of an eye, and yet the smith will seldom wear protectors. A burn caused by one of the sparks on any other part of the body will heal in a short time if proper care is taken, but the same cannot be said of the eye.

Another point in the forge-shop equipment that requires careful attention, but is often neglected, is the condition of the tools. Swages, flatters, fullers, breaking-down tools, and tools of various other kinds that are frequently subjected to sledge-hammer blows, often have their heads reduced to a burred condition. Sooner or later some of these jagged, burred projections will fly off under the hammer, and it is then purely a matter of chance as to whether or not some one is injured. Better work can be done with a good tool than with a poor one, and therefore economy as well as safety is increased by repairing or discarding tools with burred heads.

The advent of drop or stamped forgings has had an important influence on the iron and steel industry. Forgings of this kind can be turned out much more quickly than castings, and they are often much cheaper also. The uniformity in dimensions and accuracy in shape that are

characteristic of such forgings likewise adapt them very well for economical machining or finishing.

Two types of hammers are in general use for stamped forgings—namely, the board drop-hammer and the steam hammer. The board drop type is commonly used for small forgings, while the best results for large pieces are obtained by using the steam hammer. Larger forgings, plate work, and work in which bending operations are prominent, are best produced by hydraulic presses. The product of these presses is often several feet in length, and is much more massive than can be handled by drop hammers.

When drop hammers were first introduced, it was thought necessary to provide foundations having a certain amount of resiliency in order to start the hammer on its return, and at the same time remove the scale by vibration, but foundations of solid concrete are now being used with much better results than were obtained by the older type. Tar paper, or boards one or two inches thick, should be placed between the base plate and the concrete, to prevent excessive wear or grinding at the top of the foundation. It is claimed that a drop of the hammer on this type of foundation brings about better results than a drop one-third longer on the old type. This means a saving in time and power, and in some cases does away with the necessity of a second heat. The modern drop-forge shop is equipped with a suction system by means of which the scale is removed from the dies.

What has been said above regarding the necessity of protection to smiths from flying sparks applies with equal force to drop-hammer operators. In each case hot metal is worked, and although dies are used in connection with drop hammers, so that the scale cannot escape as readily as it does from the smooth surface of the smith's hammer, the drop hammer delivers far heavier blows, and the sparks that it produces are forced out at a much higher speed, and even the smallest of them gives rise to a distinctly hot, stinging sensation upon striking the body.

The operation of many of the single-frame steam hammers in use today is fraught with hazardous possibilities. The steam throttle lever is often so located that the operator's view of the work is obstructed by one of his arms, while with the other he adjusts the controlling lever. To avoid this he must stoop over in an exceedingly awkward position, and even then his view of the work may be obscured. When a battery of these hammers is in operation, the noise is so great that it is almost impossible to give oral instructions or orders to the men at the hammers, and signs must be used instead. A mistake in giving or interpreting the signs, or failure to see them, coupled with the difficulty that the operator has in seeing the condition of the work, may easily lead to accidents. The danger from this source has been largely eliminated in the newer designs of steam hammers wherein the controlling lever and the throttle lever are placed on one stud, a rod forming the connection between the throttle lever and the steam valve. The workman can then control both levers with his hands below his head, and he is thus enabled to see the progress of the work and correctly interpret the signs of his fellow workers.

Cold-press work and the trimming of forgings cause many distressing accidents unless proper precautions are taken to guard against them. The accidents from this cause are in the same class as those from punch presses.

*From the Travelers Standard, published by The Travelers Insurance Co.

Crushed hands or fingers are most commonly met with. There is a fatiguing monotony connected with the work of placing forgings in the trimming dies, and therefore the operator who does this work by hand is likely to become momentarily careless, so that once in a while a forging is not properly placed in the die. In most cases it seems impossible to overcome the desire to correct the error, even though the lever has been tripped to let the hammer fall. Under such circumstances a serious accident is almost sure to occur. This danger is so well recognized in some shops that special tools are provided, or effective safeguards are installed, or both precautions are taken.

In many shops in which forging or hammering is done, cyanide of potassium is used to a greater or lesser extent, for case-hardening. It should always be remembered that this substance is one of the deadliest poisons known, and special care should be taken to avoid taking any of it into the mouth, or inhaling any of the fumes that arise from it. Cyanide should be kept in a safe place and be plainly marked Poison, and it should not be allowed to become scattered about upon the floor, forge, anvil, or workbench. Draft hoods should also be provided for removing the fumes that are produced when working with cyanide, and nobody should be allowed to handle it unless he has been fully instructed with regard to the danger involved. This warning is specially important, because the men who use cyanide often do not know its deadly character, and it is hard to understand why more fatalities do not result from it, except upon the theory that there is a special good angel that looks after blacksmiths and others engaged in similar work, to keep them from this particular form of harm. We have seen men who should have known better (but did not), thrust pieces of hot metal into cyanide, and stand over the work with the fumes rising up all around, while they were blissfully thinking of a circus parade, or some other harmless and distant thing.

Reo Car and Reo Truck Consolidate

The Reo Motor Truck Co. and the Reo Motor Car Co., both of Lansing, Mich., will be consolidated. An exchange of shares of the car company for an equal number of shares of the truck company will place both concerns in the hands of one organization. The ownership of the two companies has been practically identical, the executive, selling and office organization performing the necessary work for both companies. Further simplification, however, will enable the company to grow more rapidly. Already there are plans for developing the business further, not only in the usual selling manner, but by changes in design. Heretofore, many parts have been used in both Reo trucks and Reo cars.

The company has purchased three city blocks between the Grand Trunk and Michigan Central tracks in Lansing in preparation for manufacturing expansions. This gives the company nearly half a mile of frontage along the Grand Trunk tracks. Erection of new buildings on the land that has been bought will be started shortly.

Kelly-Springfield to Locate in Cumberland

The removal of the plant of the Kelly-Springfield Tire Co. from Akron, O., to Cumberland, Md., is practically assured. The company has been much hampered lately in Akron, where the occupation of neighboring ground by

other plants prevented enlargement of the factory, and where housing conditions prevented increasing the force of employees. In addition to avoiding all these restrictions, the removal to Cumberland will bring the company a bonus of \$750,000, which the city is to give the company, as well as a free factory site. In the new plant the company expects to triple its production.

Reversible and Adjustable Front Seat

W. N. Nakamura, of Flint, Mich., has designed a body for which he is applying for a patent. The feature is the front seat, which is divided and so arranged that the left seat can be adjusted for a driver of any height and can be moved backward and forward to give the necessary leg room to reach the pedals.

The right seat can also be moved and if desired can be turned around so that its occupant can converse with comfort with the occupants of the rear seat. The idea of the body is two-fold. In the first place it is realized that the car cannot be designed to fit other than the average driver and since there are so many people in the world who are not average in stature it is necessary to

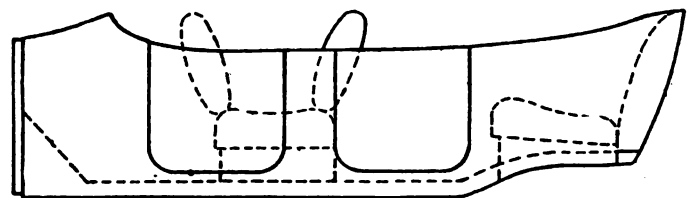
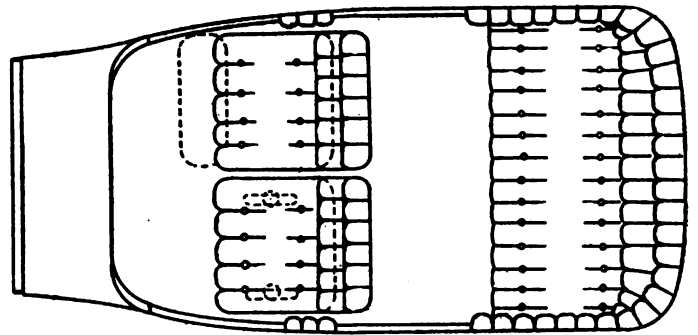

provide some means for accommodating those who are exceptionally tall or short as the case may be. Thus any driver can take care of the car and operate it in greater comfort and efficiency.

The right front seat on the other hand is often a very bad place to sit because the driver is generally too absorbed to give much of his time to conversation and it is very difficult to talk over the shoulder to the occupants of the rear seat. If a chauffeur is employed the difficulties are greater as the owner of the car, as a matter of form, is compelled to sit in the front seat with the chauffeur while his three guests are back in the tonneau. The movable right seat overcomes this objection.

Corell Michigan Sales Manager for States

George E. Corell has become Michigan sales manager for the States Motor Sales Co., Toledo, O., which recently took over the Michigan buggy factory in Kalamazoo, Mich. Already 20 dealers have been appointed in Corell's territory.

Automobile Situation in Brazil

For a number of months past, writes Consul General Alfred L. Moreau Gottschalk, Rio de Janeiro, there has been shown in the correspondence of the Rio de Janeiro consulate general, as well as in the more frequent visits of salesmen and traveling representatives from the United States, a very pronounced interest in the Brazilian field for the sale of automobiles.

Motor Cars in Rio de Janeiro

Visitors to Rio de Janeiro invariably comment on the prevalence of foreign (French, Italian, German) motor car makes, also that the city's public taxicabs show evidence of having been built for much more luxurious purposes.

The explanation of the preference for European makes in private cars is explainable from the fact that these southern countries have for years held the belief that while the United States produced and marketed foodstuffs and the grosser articles of prime necessity and sold them advantageously, none the less when anything in the nature of a luxury was to be purchased, one must naturally turn to Europe for it. To the average Brazilian an automobile is a luxury, and a luxury only.

Best Looking Taxicabs in the World

As to the superior type of taxicab in evidence, during 1912—the "boom" year of coffee, when business in general was prosperous—everyone who could afford it (and many, as the sequence shows, who could not) bought an automobile. Some were bought for cash, some on instalments, and some on credit. A few were paid for before the crash came. All of them, one may say, were from Continental Europe. Then came the panic of 1913 and the financial stringency which the depression in business of that year and the closely following European war brought about. Private automobiles were a drug on the market. Many owners of cars were glad to send them out as taxicabs to earn what they could. Others sold them outright, at a sacrifice. And that is the simple reason why Rio de Janeiro has today the best looking taxicabs in the world.

The market for automobiles in South America generally is confined, first, to the cities, and, second, to the larger plantation areas. In the cities, as explained, the luxurious European car is preferred. It is only the planter in a few scattered agricultural districts who, like the North American farmer, has begun to know the motor car that is cheap and serviceable and regarded rather as a piece of farming equipment than as a pleasure vehicle.

For the heavier vehicles, such as trucks and lorries, Brazil offers a less favorable field.

Imports During Past Four Years

The official record of Brazil's imports of automobiles graphically tells the story of the financial depression that has weighed down the republic for the past two years. In 1912 (the "boom" year), 3,785 cars were imported, these having a value of \$5,368,650; in 1913, 3,218 were imported, their value being \$4,684,069; but in 1914 the number dropped to 744 and the value to \$968,994, and last year only 214 cars were brought in, whose aggregate value was \$190,358. The United States furnished \$924,045 of the imports in 1912 and \$795,754 in 1913, and was third among the supplying countries in each of these years; but with only \$165,152 to its credit in 1914 it held second place,

and in 1915 ranked first, though its trade that year amounted to less than \$123,500.

As regards number of cars, the United States was third in 1912, second in 1913, and first both in 1914 and 1915.

Under the more normal conditions of 1912, Rio de Janeiro, the great distributing point of the republic, headed the list. Since then the financial depression has greatly lowered the country's purchasing power as a whole, and only Santos, the port of the State of Sao Paulo (which is today the principal seat of the coffee industry) has been buying automobiles—chiefly for the reason that the planter there has learned to appreciate the motor car not as an article de luxe, but properly as part of his farming equipment.

Competition After the War

A mistake that many North American traveling salesmen make, however, when they visit Brazil, is to be misled by prosperous conditions in the State of Sao Paulo, and to conclude that there lies the only field for the sale of automobiles. It is true that many motor cars have been sold there and that many more will be disposed of among the coffee planters, but I am almost convinced that the firm which has confined its efforts to the Sao Paulo country will find, in the end, that it has not done wisely. Far better would it be, to my mind, to establish lasting connections with some good selling agent at the natural distributing point, Rio de Janeiro, and let that agent sell wherever changing conditions might later warrant.

The figures given above should not encourage the American investigator of this market to think, because during the past year the United States has furnished 65 per cent of the automobiles purchased by Brazil, that that country will necessarily retain this position once the nations of Europe have reorganized their exporting. The two obstacles that will have to be faced will be the Brazilian tendency to prefer European styles, and the superior skill and more lenient terms of European competitors in marketing their goods.

A tendency toward the purchase of the smaller and more modest cars is plainly discernible in Brazil today. Four years ago a runabout on the streets of Rio de Janeiro was a curiosity. Now there are already a considerable number of the smaller cars, which are gradually replacing the larger, more expensive ones. But no American car should ever be offered here that is not fully provided with all its necessary accessories.

The question was asked me not long ago, by an American traveling representative who called at the consulate general, whether he ought not to advise his firm to establish its depot of accessories and its workshop for assembling cars at some point other than Rio de Janeiro, selecting rather some city whose topographical surroundings were level, whose roads were numerous and well kept, and whose general interests were agricultural. To my visitor's surprise, I had to answer it decidedly in the negative.

Each State Has Its Own Tariff

It should be remembered that Brazil is an assemblage of 21 states, each of which has a remarkable degree of autonomy, and that the capital city, Rio de Janeiro, is situated in a federal district that, like the District of Columbia, belongs to no one of the several states but is under the immediate jurisdiction of Congress and of a sort of municipality. As articles seven and nine of the

Brazilian Constitution provide, the federal government levies and enjoys the income from customs and other duties upon all imports. The duties which may be levied and collected upon all imports, however, are the property of the individual state where the factory is located; and each of the states has its own tariff of export charges and may vary them at its pleasure. It is this peculiarity in Brazilian law, joined to an utter absence of interstate laws concerning commerce, that makes it infinitely more profitable for a foreign corporation or manufacturer to settle within the federal district, which, outside of the usual charge for trading license, levies no duties upon production or exportation either to foreign countries or to any of the Brazilian states.

Rio de Janeiro the Distributing Center of Brazil

The city of Rio de Janeiro enjoys practically a monopoly of the distribution of merchandise throughout Brazil. This distribution is effected chiefly by means of a Government-owned railway, the Central Railway of Brazil, which penetrates from Rio de Janeiro into the interior, and by means of coastwise steamers of the Lloyd-Brasileiro Steamship Line, also a Government-owned transportation company, with a river service, a coastwise service, and ships running to the United States out of Rio de Janeiro.

The city of Rio de Janeiro is visited yearly by thousands of merchants from all the various states of the Brazilian union, being not only the political, but the commercial, legal, and social capital of the whole country.

Salesmen's Operating Licenses—Sample Cars

The American salesman who comes here with a sample car, asks first for an operating license, but the local law makes no provision for temporary operating licenses, and what he considers as no more than his due must be asked for, as a "special privilege to a foreign firm," by the consulate general. Brazil does not have two forms of licenses, one for the owner or demonstrator of a car, and another for the professional chauffeur; nor is an applicant immediately granted an operator's license without examination.

There is no class of salesmen who should more carefully remember the requirement of the Brazilian customs laws regarding samples than automobile salesmen. A salesman who has with him cars for demonstrating purposes should remember that he can not have them enter the country in bond without, before his departure from the United States, obtaining a Brazilian consular invoice declaring them to be samples.

Chalmers Revives Salesmen's Training School

A training school for salesmen along very thorough and complete lines is to be organized on October 2 by the newly organized sales promotion department of the Chalmers Motor Co. Sessions of the school will be held three times a week for several months.

It is proposed during the first month to confine the instruction given in the school to young men already members of the Chalmers factory organization.

Scattered throughout the various departments of the factory are young men of excellent education and personality. Many of these men are at a loss to know how to go about attaining their ambition to become motor car salesmen. They have natural ability, education and every

qualification necessary for the making of a good salesman, but they do not know and have little opportunity for getting in touch with conditions that would enable them to achieve their ambitions. It is to these that the new training school offers its advantages.

It is by no means the idea of the sales promotion department that a salesman can be made out of every individual. It realizes to the fullest possible extent that there are limitations and that many men never could be made into salesmen. But it also realizes that there is raw material in plenty that has not yet been utilized, and that under right conditions could be developed into excellent salesmen for the use of the company's distributors and dealers.

Details of the plan have progressed sufficiently to secure a long list of applications from Chalmers employes.

Suitable tests and examinations will be held from time to time so that the efficiency of the many salesmen may be determined, individual instructions and directions given where necessary.

Galion Buggy Builder Forms Auto Company

The Howard car is to be built by the A. Howard Co., in Galion, O., which has been incorporated with \$500,000 capital stock to take over the business of Adam Howard, buggy builder. Howard buggies will be continued by the new company, which will start with a large plant and a considerable number of dealers. A. Howard is president and general manager of the company; R. W. Johnson, vice-president, and A. W. Monroe, secretary and treasurer. The directorate consists of the officers and F. E. Garn, of Plymouth, Ind.

The stock is to be divided into \$200,000 of 7 per cent preferred stock, redeemable in 1920, and \$300,000 in common. Proceeds from the preferred will be turned over to the automobile department, while the common stock will be used in the purchase of the assets of the original company. The company will start without debt. Stock is being sold locally and to the dealers, practically all of whom have stated their willingness to handle the Howard automobile as well as Howard buggies. The car is to have 112 in. wheelbase, a 35 h.p. engine, and will be furnished in touring, coupe and sedan bodies. Its price has not yet been determined.

To Make Self-oiling Bearing Material

The Dann Products Co., Chicago, Ill., maker of the Dann spring insert for lubrication purposes, will build a plant in Cleveland, O., in which it will also make a combination of graphite and metal for bearings which, it is claimed, will not require lubrication. Three acres costing about \$17,500 have been bought in East 152d street, adjoining the new plant of the Jordon Motor Car Co. The Dann plant will cost upward of \$100,000.

Material Consumed in Making Ford Cars

The quantities of raw materials entering into a half million production of Ford cars are beyond the grasp of the average individual. First there is 200,000 tons of vanadium steel heat treated by special Ford processes, 2,000,000 each of wheels and tires, 51,950,250 square feet of rubber cloth material in the tops, 2,587,500 square feet of plate glass in the windshields with other stock in proportion.

Trade News From Near and Far

General News of the Vehicle Trade

The Gray Dort Motor Co. will build an addition to its plant at Chatham, Ont.

The Star Auto Co., Holland, Mich., has been incorporated with a capitalization of \$25,000.

The Duryea Motors Co., Inc., Philadelphia, Pa., is seeking a site for a plant in or near Baltimore.

The Hartford Auto Parts Co., of Hartford, Conn., will be known henceforth as the Connecticut Auto Parts Co.

Permits have been issued for three new automobile factory buildings for Dodge Brothers, Detroit, Mich., to cost \$343,000.

The McKinnon Dash Co., Buffalo, N. Y., is building a one-story brick addition to its factory at Amherst and Kail streets.

The Briggs & Stratton Co., Milwaukee, Wis., manufacturer of automobile specialties, will build a factory 60 x 220 ft., to cost \$100,000.

The F. H. Lawson Co., Cincinnati, O., will let contract in a few days for the proposed addition to its sheet metal plant in West End to cost \$200,000.

The White Company, Cleveland, O., automobile builder, will enlarge its plant by the erection of a one-story steel and concrete machine shop, 241 x 304 ft.

The Pilot Motor Car Co., Richmond, Ind., announces that within the next few months its plant will be enlarged to permit an increase of 50 per cent. George E. Seidel is president.

The Wing Motor Car Co., Gary, Ind., has been incorporated, with \$10,000 capital stock, to manufacture automobiles. The directors are Joseph Fluxman, A. A. Feder and William Feder.

The Schlundt Motor Co., Evansville, Ind., has been incorporated with \$25,000 capital stock to manufacture automobiles. Jabez Woolley, Clarence A. Reitz and Arthur J. Schlundt are directors.

The Star Motor Car Co., Cincinnati, O., will soon be incorporated for the purpose of erecting a plant to assemble automobiles. Louis Tyroler, Commercial Tribune Bldg., is one of the incorporators.

The Dann Products Co., Cleveland, O., has acquired a site on East 152d street, on which it will erect a plant for the manufacture of automobile spring lubricating devices. Victor Sincere and others are interested.

Confirmation of the announcement that it would spend many millions in duplicating its present plant has been made by the Ford Motor Co., Detroit. The new factory is being constructed on land adjacent to the present plant.

The Saxon Motor Car Corporation, Detroit, has purchased a factory site one block north of Michigan avenue just outside the city limits. Plans for the new building will be announced later, according to Harry W. Ford, president.

The Torbensen Axle Co., Cleveland, O., has been incor-

porated with a capital stock of \$1,750,000, to succeed the Torbensen Gear & Axle Co. It is now erecting a plant on East 152d street, Cleveland, for the manufacture of internal gear drive axles.

The Collier Motor Truck Co., Painesville, O., recently organized, will establish a plant to manufacture light motor trucks in the building formerly occupied by the Vulcan Company. M. E. Crow is president. W. A. Collier and John Crain are also identified with the company.

The Metal Auto Parts Co., of Indianapolis, Ind., has purchased the 3½-acre tract of land from E. L. Mick and others, at Chase and Henry streets, where it plans to build two large brick buildings to be used as a factory. The cost of the land and buildings will be about \$68,000.

The Stewart-Warner Speedometer Corporation, Chicago, Ill., has practically completed the transfer of the machinery and equipment of the Warner works in South Beloit, Wis., to the recently enlarged factories in Chicago and ground was broken September 1 for the new group of foundry buildings.

The A. O. Smith Co., Milwaukee, Wis., manufacturer of automobile parts and trucks, has contracted with the Milwaukee Electric Railway & Light Co. for 500 to 800 kw. of current, its own big power plant having been outgrown. An addition will probably be made and several new generating units required.

The National Motor Vehicle Co., Indianapolis, Ind., has begun the erection of two additional buildings on a plot 140 x 410 ft. The structures will be 60 x 380 ft., three stories, and 140 x 328 ft., one story, both of concrete, and will cost in all about \$150,000. It is expected the buildings will be completed by November 9.

The Nash Motors Co. of Maryland, organized by C. W. Nash and an eastern syndicate to take over the Thomas B. Jeffery Co., maker of automobiles and commercial cars, Kenosha, Wis., has been granted a license to do business in Wisconsin. The statement says the capital stock is \$5,000,000 and the Wisconsin interest is \$2,500,000.

The Ben-Hur Motor Co., Cleveland, O., has purchased a ten-acre site at Willoughby, O., where it will erect a new automobile plant. It is stated the company plans to spend about \$300,000 in the erection of a plant and that a contract for the first of three units has been placed. This building will be 150 x 400 ft., of steel and concrete.

Dodge Brothers, Detroit, will remodel their present foundry into a continuous foundry and will install new handling and other equipment, including core ovens. Plans for the changes have been prepared by Smith, Hinchman & Gryllis, engineers, Detroit, who will shortly place contracts for the required equipment.

The business of the Covert Motor Vehicle Co., Lockport, N. Y., was recently incorporated as the Covert Gear Co., and its capital stock was increased to \$1,000,000. It is erecting an additional factory building at a cost of over \$50,000, and on completion about October 1 will devote it to the manufacture of its line of transmissions. The

present officers of the company are: B. V. Covert, president; P. A. Clum, treasurer; E. F. Fritton, secretary, and F. E. Mosher, general manager.

The Enger Motor Car Co., Cincinnati, O., has been incorporated with \$4,000,000 capital stock to take over the automobile manufacturing business of a firm operating under the same name. The company will greatly enlarge its plant on Gest street, and expects to double its output of cars. Frank J. Enger continues as president.

The C. M. Yoder Co., Cleveland, O., maker of sheet metal working machinery and cold rolled steel, will enlarge its plant at Walworth avenue and West 55th street by the erection of a one-story addition, 108 x 156 ft., more than tripling its capacity. It will require some additional machinery equipment, including lathes, drill presses, shapers and grinders.

The Kissel Motor Car Co., Hartford, Wis., is making out an extensive building program for the coming winter and the first units to be undertaken at once, will be an addition, 77 x 123 ft., to the sheet metal shop, and an addition, 40 x 100 ft., to the new three-story body and finishing shop erected last spring. Details of other additions have not been completed.

The Keystone Motor Mfg. Co., manufacturer of automobile motors, which started the construction of a new plant at East Greenville, Pa., on a tract of over six acres, has now completed it and has removed from 40 North Sixth street, Reading, Pa., its former location. It has also erected a new foundry, which is now running on semi-steel for cylinder castings.

The American Auto Trimming Co., Cleveland, has been incorporated with a capital stock of \$100,000 and will establish a plant in the factory building of the Properties Co. on East 79th street for the manufacture of automobile accessories. Among those interested are Benjamin Gotfredson and Frank Joyce, both at present engaged in a similar business in Detroit.

The recently organized Napoleon Crown Fender Co., Napoleon, O., will manufacture fenders and other stamped metal parts for automobiles, and has established a plant in a leased building along the Wabash track. The officers are Cyril Donnelly, president; L. W. Schultz, vice-president; Gerald Donnelly, secretary and treasurer, and W. A. Bockalman, general manager.

The Peerless Motor Car Co., Cleveland, O., will place a contract shortly for the erection of three buildings for the manufacture of pleasure cars, allowing its present plant to be devoted exclusively to the manufacture of motor trucks. The plans provide for a three-story reinforced concrete building, 60 x 270 ft., a three-story building, 53 x 161 ft., for body making and chassis assembling, and a one-story building of the saw tooth type, to be used for final assembling.

Approximately \$1,000,000 was involved in a deal recently by which the Lozier Motor Car Co. sold its property at Mack avenue and the Terminal Railroad to the Motor Products Co. Fifteen of the 60 acres purchased are covered by modern factory buildings. It is understood that the Motor Products Co., which was recently formed to take over the business of five manufacturers of motor car parts, will enlarge the factories which it has purchased, while the Lozier company will use the money obtained in the sale in buying or erecting another factory.

Doings of the Motor Truck Builders

The Clyde Motor Truck Company of New York has closed a contract for 204 one-ton trucks, which are to be shipped to Australia.

The Peerless Motor and Truck Co., Cleveland, O., will build an addition to take care of the European order for trucks recently received.

Clifford S. Goby and others are interested in the Motor Trucks Company, Cleveland, which has been incorporated with a capital stock of \$35,000.

The Redden Motor Truck Co., Detroit, Mich., has recapitalized at 500,000 in order to expand its business. It manufactures an attachment for making a Ford into a one-ton truck.

The Curtis Form-A-Tractor Co., Chicago, Ill., is negotiating with the business men's associations at Green Bay, Fond du Lac and Madison, Wis., for a location of its proposed plant and headquarters.

The Rush Motor Truck Co., of Philadelphia, was recently incorporated for \$500,000, to manufacture motor trucks and automobiles. The incorporators are Charles L. Guerin, J. D. Morelli and Emanuel Nageli, Jr.

A. D. Groves of Ann Arbor, Mich., has been appointed receiver for the Star Motor Car Company, which manufactured a light truck. The receiver will determine whether it is advisable to continue the business or sell it.

One of the Allied governments has placed through Gaston, Williams & Wigmore an order for 2400 Peerless trucks, delivery to commence immediately. Delivery will be made at the rate of from 80 to 100 trucks a week until late in 1917.

The Four Wheel Drive Tractor Co., Clintonville, Wis., is considering offers from business men's associations at Oshkosh, Shawano and other Wisconsin cities for a location for its works and headquarters. Dr. Charles Topp is president.

The Chester County Motor Co., Coatesville, Pa., will move to Philadelphia, Pa., where its plant will be located at Cherry Street, near Fifty-eighth Street. This company, of which J. E. Brinton is president, has been manufacturing a light gasoline commercial vehicle.

The Continental Motor Truck Co., Superior, Wis., has broken ground for its new \$50,000 factory at Belknap St. and the Soo line tracks. The shop is to be ready November 1, at which time the output of trucks will be largely increased. Dr. J. G. Barnsdale is general manager.

The Allen Street Sweeper and Auto Co., Allentown, Pa., will open a plant for the manufacture of commercial vehicles and street-cleaning machines. H. S. F. Barner, 1421 Munroe St., Allentown, general manager, was connected for twelve years with the Mack truck company.

The Larrabee-Deyo Motor Truck Co., Inc., Binghamton, N. Y., is manufacturing two sizes of commercial cars, 1½-ton and 2½-ton machines, equipped with Continental engines, Fuller transmission, Bosch magnetos, Schebler carbureters, Sheldon axles and springs and David Brown type worm gear drive.

The Union Truck Co. at Bay City, Mich., recently organized, will construct a truck designed by H. E. Woodworth, vice president and general manager of the company. The company is officered as follows: President, J. R. Tanner; vice president and general manager, H. E.

Woodworth; secretary, E. C. Tibbets; treasurer, George Beaulier.

The H. J. Koehler Motors Corp. has been formed at Newark, N. J., with a capital of \$425,000 to succeed the H. J. Koehler S. G. Co. and the L. E. Schlotterback Mfg. Co. The Schlotterback company was the factor for the Koehler company, which designed and sold the Koehler one-ton truck. The combination is for the purpose of increasing production. H. J. Koehler remains the president of the new concern and the product and its price, \$895, are unchanged.

The Higrade Motors Company, Buffalo, N. Y., has been incorporated with a capital stock of \$250,000 and will manufacture a medium size motor truck, weighing about 2200 lbs. The incorporators are J. Elmer Pratt, 67 Beard Ave., Buffalo, formerly sales manager of the Pierce-Arrow Motor Car Co.; L. W. Coppock, Grand Rapids, Mich., and William J. Loomis, Ionia, Mich. Arrangements are being completed for the establishment and equipment of a plant at Grand Rapids, Mich.

The Denmo, a new assembled truck, has just been put on the market by the Denneen Motor Co., Cleveland, O. The truck sells for \$1,385 chassis, and is rated to carry 1¼ tons. It has a lighting and starting system. The engine is a Wisconsin four, 3¾ x 5 in. and transmission is through a three-speed gearset to a Torbensen internal gear axle. There is a governor driven from the propeller shaft, so that it is the truck speed which is controlled. Nine feet of loading space are provided, the wheelbase being 124 in., but it is stated that the truck will turn in 21 ft., as a very wide steering lock.

The Clyde Motor Truck Company has purchased five acres at Farmingdale, Long Island, having 15,000 ft. front on the Long Island Railroad, with option on an adjoining 40 acres, and will construct a one-story factory of saw-tooth type, having about 12,000 sq. ft. of floor space for the manufacture of motor trucks. It is incorporated for \$750,000. Mahlon C. Swartz is president; W. J. Melhiush, Jr., recently with the White Motor Co., is vice-president and general manager; P. R. MacLean, formerly American representative of Frazer & Best, Ltd., foreign motor vehicle exporters, is secretary and export manager; E. E. Vreeland, president of E. E. Vreeland, Inc. (advertising), is treasurer. P. J. Holdworth, formerly of the Chalmers Motor Car Co., is efficiency engineer and W. J. Kenlon, formerly with the Christy Front Drive Motor Co., is factory representative.

Body Builders Briefs

The Mitchell Wagon Co., Racine, Wis., is enlarging its facilities to cope with the demand for automobile bodies for the Mitchell Motors Corporation, Racine. Additional operating room is being provided. The bodies are sheet-metal products.

The Highland Body Mfg. Co., Cincinnati, O., has received an order from the United States War Department for 100 1½-ton bodies at \$123 each, to be delivered within six weeks. The Troy Wagon Works, of Troy, O., received an order for 200 1½-ton bodies at \$136.75, and 200 3-ton bodies at \$152.60, to be delivered in six weeks.

A 1000 per cent increase in orders during the last twelve

months has been made by the Springfield (Mass.) Body Co. Those companies which have adopted the Springfield body as standard equipment include: Abbott-Detroit; Cadillac; Cole; Davis; Haynes; Interstate; Marmon; Mitchell; Oldsmobile; Overland; Paige-Detroit; H. A. L.; Reo; Stearns; Studebaker; Velie; Westcott and Winton.

The Standard Woven Fabric Co., which recently moved to Walpole, Mass., has sold its plant at Framingham and it is to be occupied by the Bela Body Co., of Amesbury, who will operate the whole property for the production of automobile bodies. The main building is of modern concrete construction, 53 by 224, three stories, having about 40,000 ft. of manufacturing space, and an attached fireproof boiler house, all equipped with sprinkler system and other modern conveniences. There is 108,720 ft. of land bordering on the railroad. Town assessment places \$43,550 on the building and \$7,570 on the land, making a total of \$51,120.

Harroun to Produce Light Car

Ray Harroun, well known racing engineer, and up to last January chief engineer of the Maxwell Motor Co., has completed plans for launching a low-priced car of his own design. He has been working on this car for two years. There will be ten sample cars ready for the January shows. Production will start for dealers in March and by May 1 the organization is expected to be embarked on quantity production. It is planned that 25,000 cars will be made between May 1 of the first year and May 1 of the second.

The Harroun car will be distinguished by a large number of pressed steel parts. It is to sell for \$595, is to be introduced in the form of a five-passenger four-cylinder light construction of 107 in. wheelbase. It has been worked out with a view to combining with economical construction certain ideals of the designer with respect to performance and riding comfort. Temporary manufacturing facilities have been procured by the securing of a factory at Wayne, Mich., which has been used for carriage manufacture heretofore, while the establishment of the large plant that will be needed in the development of the Harroun project is rendered possible by the 16-acre plot that goes with the plant.

John Guy Monihan is president of the new organization. He was formerly with the Premier company and was later vice-president and general manager of the Marion. Ward Macy will be in charge of sales and Paul Bruske of advertising.

Death Follows Firestone Outing

The annual outing of the factory heads of the Firestone Tire & Rubber Co., Akron, O., was marred by an accident in which one of the automobiles that was conveying the men to the home of A. C. Miller, vice-president, overturned. Grover I. Myers, head of the pneumatic tire department, was severely injured, and died on August 29. The other men in the car, which was one of a procession of 60 machines, were not injured. Outside of this, the trip was a most successful one. The men left the factory Saturday morning, and did not return until Monday, after having covered a good part of Ohio by automobile.

Aeronautical Men Join S. A. E.

Members of the American Society of Aeronautical Engineers will be admitted to membership of the Society of Automobile Engineers without the payment of annual dues if they enter the fold within three months, according to a decision reached at a meeting of the S. A. E. council in New York. About 30 aeronautical members have already applied for membership through desire to co-operate with the S. A. E. under its new name, the Society of Automotive Engineers, which will be assumed from the first of the coming year, if present plans are carried out.

At the council meeting no less than 101 new members were admitted, 11 being juniors, 37 associates and 53 full members. C. W. McKinley, engineer of the Willys-Overland Co., was elected to membership in the council, succeeding H. M. Leland.

The treasurer's report showed the society to be in a most satisfactory condition. By October 1, when the fiscal year ends, the total assets will be \$30,000, while at the end of the preceding year they were but little more than \$8,000. Investments will bring the society some \$1,100 income during the coming year.

Stanley Steamer for Rail Use

As a development of its steam engine applicable to railway cars, the Stanley Automobile Co., of Newton, Mass., has just completed and sold to the Vermont Central Railroad an experimental car with a 60 h.p. Stanley power plant attached. The car will be run on a 12-mile spur of the railroad, several times daily, acting as a feeder to the main line. It will have a trailer attached as traffic demands. Kerosene oil is used as fuel and 30 miles an hour is easily attainable. The weight of the entire power plant including boiler is about 3,000 pounds.

WANTS

Help and situation wanted advertisements, 1 cent a word; all other advertisements in this department, 5 cents a word; initials and figures count as words. Minimum price, 30 cents for each advertisement.

PATENTS

Patents—H. W. T. Jenner, patent attorney and mechanical expert, 606 F St., Washington, D. C. Established 1883. I make a free examination and report if a patent can be had and exactly what it will cost. Send for circular.



Meyer Threads
 CAN BE HAD
 IN ANY SIZE
 OR COLOR
 THAT IS
 WANTED
 Send in your
 orders at once
JOHN C. MEYER
THREAD WORKS
LOWELL, MASS.

Index To Advertisers

Acme Die Casting Corporation.....	3
Acme Rubber Mfg. Co.....	38
Anti-Borax Comp. Co.....	40
Barrell Co., Wm. L.....	39
Bliss, E. W. Co.....	3
Bookwalter Wheel Co.....	38
Bradley, C. C., & Son.....	37
Brawley, T. R.....	2
Buob & Scheu.....	38
Cargill Co., The.....	6
Columbus Bending Co.....	38
Columbus Bolt Works.....	40
Cowles, C., & Co.....	38
Cumberland Hotel.....	36
Decker, J. C.....	38
Doehler Die Casting Co.....	2
Dowler, Chas. L.....	38
DuPont Fabrikoid Co.....	6
Eccles, Richard, Co.....	6
Fairfield Rubber Co.....	39
Felton, Sibley & Co.....	40
Hartford Clock Co., The.....	8
Hoopes Bro. & Darlington.....	39
International Rubber Co.....	37
Jenner, H. W. T.....	35
Johnston Paint Co.....	38
Keratol Co., The.....	8
Lawson, F. H., Co.....	6
Mather Spring Co.....	38
Meyer, John C., Co.....	35
Millersburg Fifth Wheel Co.....	38
Mott Wheel Works.....	39
Mulholland Co., The.....	38
Murcott-Duden Co., The.....	3
Parrott Varnish Co.....	38
Payne, E. Scott, Co.....	38
Porter, H. K.....	2
Russel, Burdsall & Ward Bolt & Nut Co.....	37
St. Marys Wheel & Spoke Co.....	2
Sheldon Axle & Spring Co.....	1
Shepard, H. S., & Sons.....	38
Sherwin-Williams Co.....	4
Shortsville Wheel Co.....	4
Smith, H. Collier.....	2
Standard Oil Cloth Co.....	5
Technical School for Carriage Draftsmen.....	36
Valentine & Co.....	40
West Tire Setter Co.....	4
White-Quehl Mfg. Co.....	38
Wilcox Mfg. Co., D.....	38
Willey Co., C. A.....	7
Williams, J. H., & Co.....	8
Wing, Chas., Co.....	38
Zwick & Greenwald Wheel Co.....	38

HOTEL CUMBERLAND

NEW YORK

Broadway at 54th Street

Near 50th Street Subway Station and 53d Street L



Broadway Cars from Grand Central Depot.

Seventh Avenue Cars from Pennsylvania Station.

NEW AND FIRE-PROOF

Best Hotel Accommodations in New York at Reasonable Rates.

\$2.50 with Bath and Up

EUROPEAN PLAN

All Hardwood Floors and Oriental Rugs.

Ten Minutes' Walk to 40 Theatres

Excellent Restaurant. Prices Moderate.
Send for Booklet.

HARRY P. STIMSON

Only New York Hotel window-screened throughout

Carriage Mechanics

Desiring to improve their present Condition should attend the

TECHNICAL SCHOOL

FOR

Carriage Draftsmen and Mechanics

SUPPORTED BY THE

Carriage Builders' National Ass'n

The object of the School is to teach men to design vehicles and make working drawings, and to otherwise facilitate their work in the shop. Only those men employed in carriage or automobile building or their accessory trades are admitted to its privileges.

The classes are conducted in three divisions, viz.: Corresponding, Day, and Evening. The former is open during the entire year, while the day and evening classes are in session only from October 1 to April 1.

The tuition is moderate.

For prospectus and full particulars, write to the instructor,
ANDREW F. JOHNSON,
20 West Forty-fourth St.,
NEW YORK CITY

CLASSIFIED INDEX

For Addresses See Alphabetical Index
and Advertising Pages

AUTO AND BUGGY TOPS

Buob & Scheu, Cincinnati, O.

AUTO FABRICS

Acme Rubber Mfg. Co., Trenton, N. J.

Barrell, Wm. L., Co., New York
Laidlaw Co., Inc., The, New York.

AXLES (Including Ball and Roller Bearing)

Sheldon Axle & Spring Co., Wilkes-Barre, Pa.

BOLTS AND NUTS

Columbus (O.) Bolt Works Co.
Russell, Hurdall & Ward Bolt & Nut Co., Port Chester, N.Y.

BOLT CLIPPERS

Porter, H. K., Everett, Mass.

BRAZING SLEEVES

White-Quehl Mfg. Co., Cincinnati, O.

CLOCKS

Hartford Clock Co., Inc., New York City.

DIE CASTINGS

Acme Die Casting Corp., Brooklyn, N. Y.

Doehler Die Casting Co., Brooklyn, N. Y.

FIFTH WHEELS

Millersburg Fifth Wheel Co., The, Millersburg, Pa.

Wilcox Mfg. Co., D., Mechanicsburg, Pa.

HARDWARE (Carriage, Wagon and Automobile)

Columbus (O.) Bolt Works Co.
Dowler, Chas. L., Philadelphia.
Eccles Co., Richard, Auburn, N. Y.

Wilcox Mfg. Co., D., Mechanicsburg, Pa.

Wing Co., Chas., Amesbury, Mass.

Cowles, C., & Co., New Haven, Conn.

Payne Co., E. Scott, Baltimore.

LEATHER SUBSTITUTES

Barrell Co., Wm. L., New York.
International Rubber Co., New York City.

Keratol Co., The, Newark, N. J.
O'Bannon Corp., New York.
Standard Oil Cloth Co., New York.

DuPont Fabrikoid Co., Wilmington, Del.

MACHINERY AND TOOLS

Bliss Co., E. W., Brooklyn, N.Y.
Smith, H. Collier, Detroit, Mich.
West Tire Setter Co., Rochester, N. Y.

Williams, J. H., & Co., Brooklyn, N. Y.

White-Quehl Mfg. Co., Cincinnati, O.

MACHINERY (Metal Working)

Bliss Co., E. W., Brooklyn, N.Y.
Smith, H. Collier, Detroit, Mich.

METAL STAMPINGS AND NOVELTIES

Murcott-Duden Co., Inc., New York.

PATENTS

Jenner, H. W. T., Washington, D. C.

PAINTS AND COLORS

Felton, Sibley & Co., Inc., Philadelphia, Pa.

Johnston Paint Co., R. F., Cincinnati, O.

Sherwin-Williams Co., Cleveland, O.

Valentine & Company, 456 4th Ave., New York; 343 S. Dearborn St., Chicago; 74 Pearl St., Boston.

Willey Co., C. A., Hunter's Point, N. Y.

PASTE

Indianapolis (Ind.) Paste Co.

SCHOOL FOR DRAUGHTSMEN

Mechanics' Institute, New York

SHAFT COUPLINGS

Bradley & Son, C. C., Syracuse, N. Y.

Eccles Co., Richard, Auburn, N. Y.

SPRINGS

Mather Spring Co., Toledo, O.

Mulholland Co., Dunkirk, N. Y.

Sheldon Axle & Spring Co., Wilkes-Barre, Pa.

THREADS

Meyer, Jno. C. & Co., Lowell, Mass.

VARNISH AND JAPAN

Felton, Sibley & Co., Inc., Philadelphia, Pa.

Parrott Varnish Co., Bridgeport, Conn.

Sherwin-Williams Co., Cleveland, O.

Valentine & Company, 456 4th Ave., New York; 343 S. Dearborn St., Chicago; 74 Pearl St., Boston.

Willey Co., C. A., Hunter's Point, N. Y.

WELDING COMPOUND

Anti-Borax Compound Co., Ft. Wayne, Ind.

WHEELS

Bookwalter Wheel Co., Miamisburg, O.

Hoopes Bros. & Darlington, Inc., West Chester, Pa.

Mott Wheel Works, Utica, N. Y. (wire).

St. Mary's Wheel & Spoke Co., St. Mary's, O.

Shortsville (N. Y.) Wheel Co.

Zwick & Greenwald Wheel Co., Dayton, O.

WOOD BENDINGS, WHEEL STOCK, ETC.

Columbus (O.) Bending Co.

St. Mary's Wheel & Spoke Co., St. Mary's, O.

Shepard, H. G., & Sons, New Haven, Conn.

TEMPERED STEEL RING



The Only One-piece Moulded Leather Packing

The Bradley Carriage Coupler

All-Steel Noiseless Quick-Shifting Ball-Bearing

(MADE IN FIVE SIZES FOR AXLES 3/4 INCH TO 2 1/4 INCH)

The only carriage coupler that is furnished with a ONE-PIECE MOULDED LEATHER PACKING

C. C. BRADLEY & SON, Syracuse, N. Y.

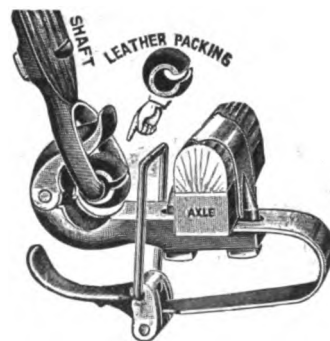

The Bradley Carriage Coupler

C. B. N. A. OFFICIAL CONVENTION NOTICE

Office of the Secretary and Treasurer, Mount Vernon, N. Y., September 2, 1916 .

The Carriage Builders' National Association extends to the Carriage, Wagon and Sleigh builders of the United States a cordial invitation to attend the Forty-fourth Annual Convention of their Association at Cincinnati, O., September 25 to 29 of this year.

A visit to the Convention and Exhibition of the materials used in the construction of your products and in your business, and a few days spent in the hospitable and interesting city of Cincinnati cannot help being of benefit to you in every way.

The Association will be happy to see you and you will be welcome whether a member or not. The Convention and Exhibition are free to every Vehicle Builder, as our sole purpose is to benefit all builders of Vehicles.

By direction of the Association,
HENRY C. McLEAR, Secretary.

RUSSELL, BURDSALL & WARD BOLT & NUT CO.

Established 1845

PORT CHESTER, N. Y.

MAKERS OF THE CELEBRATED EMPIRE BOLTS AND NUTS

Western Office: Continental & Commercial Bank Bldg., Chicago, Ill. Branch Works: Rock Falls, Ill.

"INTERNATIONAL" RUBBER CARRIAGE CLOTH

The Rubber Carriage Cloth of SERVICE and QUALITY

Write for Samples and Prices

INTERNATIONAL RUBBER CO.

225 Fifth Avenue, New York

Please mention "The Hub" when you write

BUSY BUYERS BRIEFS



Manufacturers
FIFTH WHEELS
All Varieties
Heavy Goods a
Specialty

Iron and Steel Rings from 4 to
60 inches wide

MILLERSBURG FIFTH WHEEL CO.
Millersburg, Pa.

The Zwick & Greenwald Wheel Co.

High Grade Vehicle
WHEELS

DAYTON - - OHIO

WE MANUFACTURE
FINE VEHICLE
WHEELS

The Bookwalter Wheel Co.
MIAMISBURG, OHIO

**JOHNSTON'S
KRAKNO**

Color Card Free
\$3.50 per gallon

The R. F. Johnston Paint Co.
Cincinnati, Ohio

*Mather Springs
Scientifically Heat Treated.*



THE MATHER SPRING CO. — TOLEDO OHIO

THE CHARLES WING CO.

Established 1848

Manufacturers and Wholesale Dealers in
**AUTOMOBILE AND CARRIAGE
HARDWARE AND TRIMMINGS**
AMESBURY, MASS., U. S. A.

The Best Possible in

Bent Wood

H. S. SHEPARD & SONS
New Haven, Conn.



The **PARROTT
VARNISH CO.**
BRIDGEPORT, CONN.
Automobile, Coach and Wagon
VARNISHES
and **VARNISH REMOVER**

Columbus Bending Co.

Successors to The Wildermuth Bending Co.
COLUMBUS, OHIO

Manufacturers
of **BENT RIMS**
For Wagon, Carriage and Auto Wheels

Why Not Have the Best?

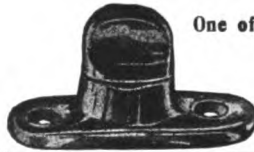

One of a Large Variety

G. Cowles & Co.
NEW HAVEN,
CONN.

J. C. DECKER

MONTGOMERY, PA.
Manufacturer of

Carriage, Skate and Pad Straps

Side Loops, Bridle Fronts, Tail Ties, etc.

SUBSCRIBE FOR
THE HUB
\$2 PER YEAR

E. SCOTT PAYNE CO.

Carriage and Automobile
HARDWARE

Horse - Shoers' Supplies
362-364 North Gay St., Baltimore, Md.

CHARLES L. DOWLER

CARRIAGE AND WAGON HARDWARE

108 North Third St., Philadelphia, Pa.

CUSHION MANUFACTURER

Pure Stearic Acid Candles. Wheel Stock. Snow
Flake Axle Grease.

**Automobile and Carriage Leathers,
Leather Welts and Gimps**

All Kinds of Leather Specialties
WRITE US FOR PRICES

THE GEO. R. CARTER CO.
CONNERSVILLE, IND.

**MULHOLLAND
BUGGY SPRING**

Reduces weight of springs one-half.
Made in one size only but will fit bodies
of all widths.

Write for further particulars and prices.
THE MULHOLLAND CO. DUNKIRK, N. Y.

White's Brazing Sleeves

For applying Rubber Tires
Send for Samples.

WHITE-QUEHL MFG. CO.

431 E. Pearl St.
CINCINNATI, OHIO

Save One-half the Cost of a New Auto Top



Write for Order Blank, Sample Card and Catalog
**BUOB & SCHEU 1000 E. Court St.
CINCINNATI, OHIO**

WILCOX

FINE
FINISHED
FORGED

**CARRIAGE HARDWARE
AND GEAR IRONS**

Write for Prices and Catalog

The D. Wilcox Mfg. Co.

MECHANICSBURG, PA.

Acme

means

Highest Quality

in

Rubber Carriage Cloths

Acme Rubber Mfg. Co., Trenton, N. J.

HOOPES BRO. & DARLINGTON

(INCORPORATED)

WEST CHESTER, PA.

WE ARE MAKING

AUTOMOBILE WHEELS

Forty Years' Experience as WHEEL MAKERS is guarantee we can make good ones.
Will not make any other kind. Try them.

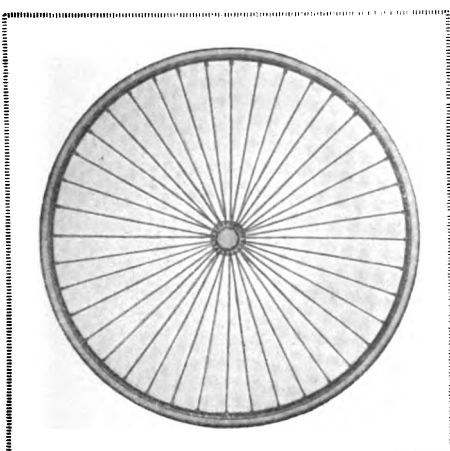

ANOTHER BIG YEAR FOR MOTT WIRE WHEELS

Reports from all parts of the country indicate that next season will see more Mott Wire Carriage Wheels used than ever before. In these days of severe competition, there must be some good reasons why the demand for Mott Wire Wheels is steadily increasing. Here are some indisputable sales features:

1. Mott Wire Wheels are satisfactory and serviceable in all weather and climates. Heat and dampness have no effect upon them.
2. They give the carriage a more neat and attractive appearance, which appeals to the prospective customer. This means more sales.
3. Even in severe accidents, Mott Wire Wheels do not collapse or fall apart. The occupants of the carriage are always safer than with any other type of wheel.
4. The wire spokes act largely as extra springs and produce comfortable, easy riding on all roads.
5. Mott wheels are always made of the best steel obtainable. The quality never varies and there are not four or five different grades to confuse the buyer.

These are only a few of the reasons why the acknowledged leaders of the carriage industry have already contracted for largely increased quantities of Mott Wire Wheels. The same selling arguments for carriages equipped with Mott Wire Wheels, will help other manufacturers to be busier than they were last season. Let us hear from you.

THE MOTT WHEEL WORKS, UTICA, N. Y.

THE FAIRFIELD RUBBER COMPANY

Manufacturers of

Carriage Cloth, Imitation Leather,

Automobile Cloths, etc.

FAIRFIELD,

CONNECTICUT



QUALITY

Automobile Top Fabrics and Cotton Duck

WRITE FOR SAMPLES

WILLIAM L. BARRELL COMPANY
NEW YORK

Valentine's Painting Materials

Valentine's varnishes are the highest grade vehicle varnishes made—that is, the most brilliant, most easily used, and most durable. Also, they are of necessity the most expensive; by using them the makers of all the best automobiles and carriages show that they pursue the

policy of equipping their products with the best materials, whatever their cost. Owners of automobiles and carriages should ask for Valentine materials when having them re-finished. Any vehicle painter will use them if specified. Most painters use them regularly.

Write for our book, "The Care of the Car"



Valentine & Company

Largest Manufacturers of High Grade Varnishes in the World

456 Fourth Ave., New York 343 S. Dearborn St., Chicago 74 Pearl St., Boston



"E-Z" Welding Compound is the best for general welding.

Because it sticks to the metal at a low heat.

Because it makes perfect welds at fully 250 degrees lower heat than any other.

Because it does not boil up and waste while fluxing.
Because it prevents slipping of laps.

Manufactured only by

ANTI-BORAX COMPOUND COMPANY, Fort Wayne, Ind.



CRESCENT Welding Compound is the best substitute for borax known. It is particularly good for welding under dies

and where parts are fastened together before welding, like Toe Calks, etc.

FOR SALE BY ALL JOBBERS
Samples Sent Free



Skewed Shaft Couplings

Regular or Oval Patterns
For High Arched Axles

Furnished in rights and lefts for any height of arch.
Oval Axle Clips $\frac{5}{8}$ or $\frac{3}{4}$ width to match Oval Couplings. Bolts, Clips, Couplings, Carriage Hardware and Special Forgings

Catalogue "H" and Prices on Application

COLUMBUS BOLT WORKS COMPANY
COLUMBUS, OHIO

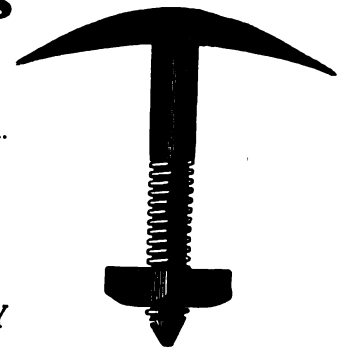

Don't Search for Quality
With Your Eyes Shut

"F-S" Quality Coach, Carriage and Automobile Varnishes and Japans have built up a strong reputation for reliability through over half a century of giving thorough satisfaction. They are standards because only the best-grade ingredients go into them.

FELTON, SIBLEY & CO., Inc.

Manufacturers of
Colors, Paints and Varnishes since 1863

136-140 North Fourth Street
PHILADELPHIA

The Hub

First Journal of the Vehicle Industry

Vol. LVIII

NEW YORK, OCTOBER, 1916

No. 7

DEALERS WILL SELL YOUR TRUCK IF EQUIPPED WITH SMITH WHEELS

METAL



"EVERLASTING"

Smith Wheels Guaranteed during LIFE OF TRUCK on which originally placed

Smith Wheels made for trucks of any size and to fit any axle

Tire Mileage Increased—Gasoline Mileage Increased—Truck Life Increased!

SMITH MANUFACTURING SUCCESSES:

L. C. SMITH GUN

SMITH PREMIER TYPEWRITER

ITHACA GUN

L. C. SMITH & BROS. TYPEWRITER

SMITH WHEEL
SYRACUSE, N.Y. U.S.A.

Buy "Hickory Nut," "Acorn" Vehicle Wheels

You cannot buy better wheels dollar for dollar paid. A bad wheel is a big "Leak" in your business.

STOP THAT LEAK TODAY
By Asking Your Jobber for
WHEELS "MADE IN ST. MARYS"

Export Office: 8 Bridge St., NEW YORK CITY
Factories: ST. MARYS, O.; RICHMOND, VA.

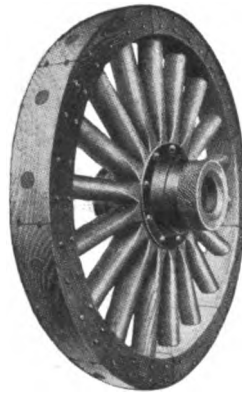

and "Star" Brand Carriage Woodstock

We make a specialty of Spokes, Hubs, Bent Hickory and Oak Rims, Poles, Shafts, Singletrees, etc., for New Work or Repairs.

Buy "Star" Brand and be a satisfied customer.

INSIST ON OUR BRANDS

St. Marys Wheel & Spoke Co.
Consolidated with CRANE & MacMAHON, Inc.
ST. MARYS, O. :: U. S. A.

steel stampings

no munitions—American Industries first

THE PRESSED STEEL CO. OF N. Y.

141 Broadway, N. Y. City



85-87 ADAMS ST.
BROOKLYN, N.Y.

Felts for the Automobile and Machinery Trades a Specialty

DUST RINGS FOR HUBS STRIPS FOR CRANK CASES
FELT WASHERS AND GASKETS FOR ALL LUBRICATING AND DUST EXCLUDING PURPOSES

No order too small to receive prompt and most careful attention



MEYER THREADS

CAN BE HAD IN ANY SIZE OR COLOR THAT IS WANTED

Send in your orders at once

**JOHN C. MEYER
THREAD WORKS
LOWELL, MASS.**

Bliss Power Presses—Standard for 58 Years

When you buy a press, keep this one fact in mind: You are buying for now and for the future. Machinery is the last thing on which to try to save money. No press can be too good for you—too strong or too serviceable.



Buy Bliss Presses



And make an investment that pays dividends in money saved on power consumption, on repairs and money saved by increased efficiency. You are assured of absolutely steady, reliable service.

There is a Bliss Press to successfully meet every sheet metal working requirement. Write today, advising your requirements.

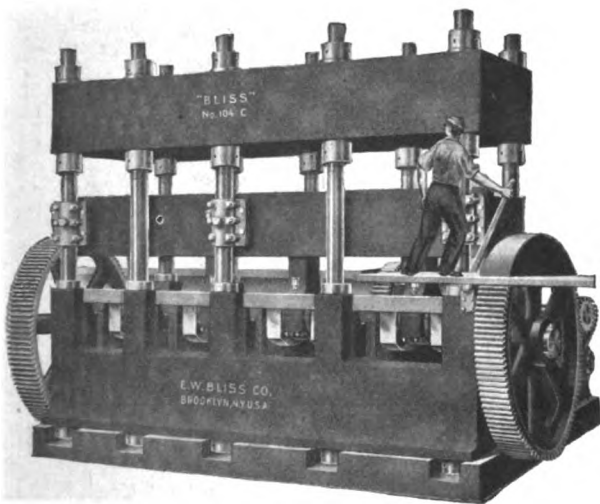

"Bliss" Bottom Slide Multiple-Crank Press No. 104-C. Weight, 140,000 lbs.

Built in a large number of sizes "Bliss" Bottom Slide Multiple Crank Presses are specially designed for forming automobile side frames and cross-rails, steel-car parts, fence posts, channels, angles and miscellaneous heavy forming work of like character.

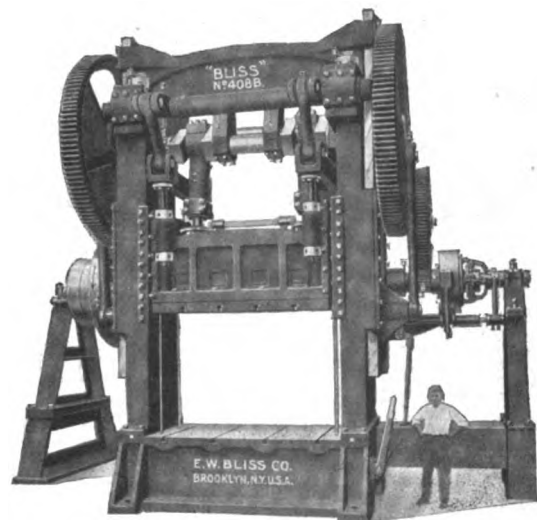

"Bliss" No. 408-B Double-Crank Toggle Drawing Press. Weight, 125,000 lbs.

Built in many sizes "Bliss" Double-Crank Toggle-Drawing Presses are adapted for drawing and forming from heavy stock irregular and oblong shaped articles of large area such as automobile radiators, fenders, running boards, engine pans, gear covers, doors, etc.

"THERE IS A BLISS PRESS FOR EVERY REQUIREMENT"

E. W. BLISS CO., 38 Adams St., Brooklyn, N. Y.

Chicago Office: 622 West Washington Boulevard.

Detroit Office: Dime Bank Building

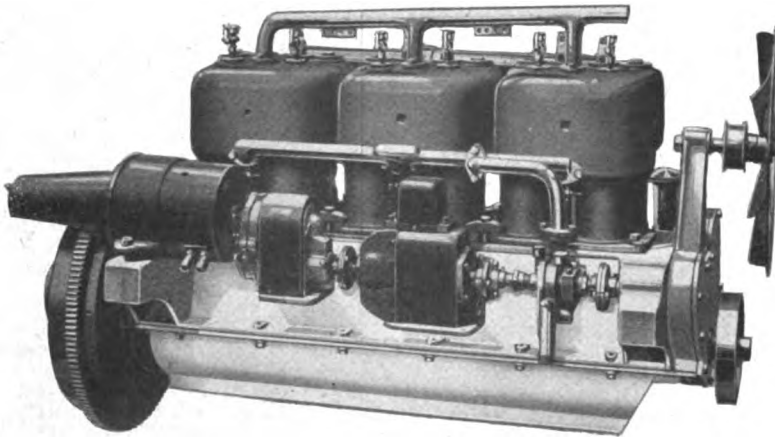

Model 6B Motor, 4½" bore by 5" stroke

Quality and Service

are the two essentials that for 17 years have been built into

BRENNAN STANDARD MOTORS

The manufacturer of Commercial or Pleasure cars who equips his product with Brennan Standard Motors can feel assured his every requirement regarding this vital part has been fulfilled.

Built in the following sizes:

- 4 Cylinder Model M—4 x 5
- 4 Cylinder Model B—4½ x 5
- 4 Cylinder Model 11—5 x 5

- 4 Cylinder Model 12—5½ x 6
- 4 Cylinder Model 12—6 x 6
- 6 Cylinder Model 6B—4½ x 5

Let us send bulletins telling *why* Brennan Motors are *standard* motors

BRENNAN MOTOR MFG. CO., Syracuse, N. Y.

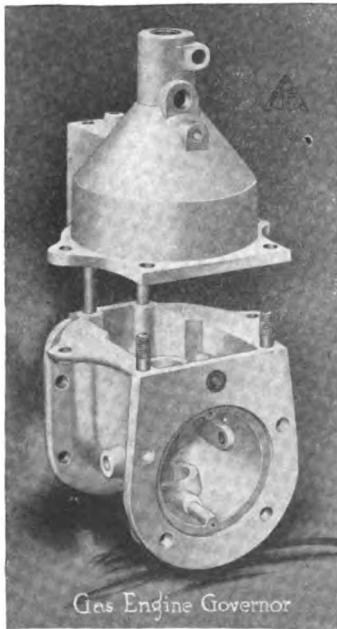

Gas Engine Governor

Examine an ACME Die-Casting

Test it in every way. Note the close-grained, homogeneous metal, the accuracy, the consistency of the product, and the beautiful finish. The illustration is an example of what we are doing for others. Come to our factory, if you can, and see the character of the work we are shipping. You would need no more convincing argument of the fact that we can aid vehicle makers to derive the utmost benefit from the Die-Casting process. Send blue prints or models for estimates.

Acme Die-Casting Corporation

Bush Terminal Bldg. No. 5 35th St. and Third Ave.
BROOKLYN, N. Y.

SALES OFFICES:

Boston—176 Federal St. Chicago—549 Wash. Blvd
Philadelphia—Widener Bldg. Detroit—965 Woodward Ave.

CANADIAN DISTRIBUTORS:

Lyman Tube & Supply Co., Ltd., Montreal



DOEHLER DIE-CASTINGS

are the standard of comparison in the ever growing die-casting field. The superiority of



Aluminum Die-Cast Magneto Housing

“Doehler” quality and the unfailing reliability of “Doehler” service have attained for them this enviable position.

DOEHLER DIE-CASTING CO.

BROOKLYN, N. Y.
NEWARK, N. J. TOLEDO, OHIO.

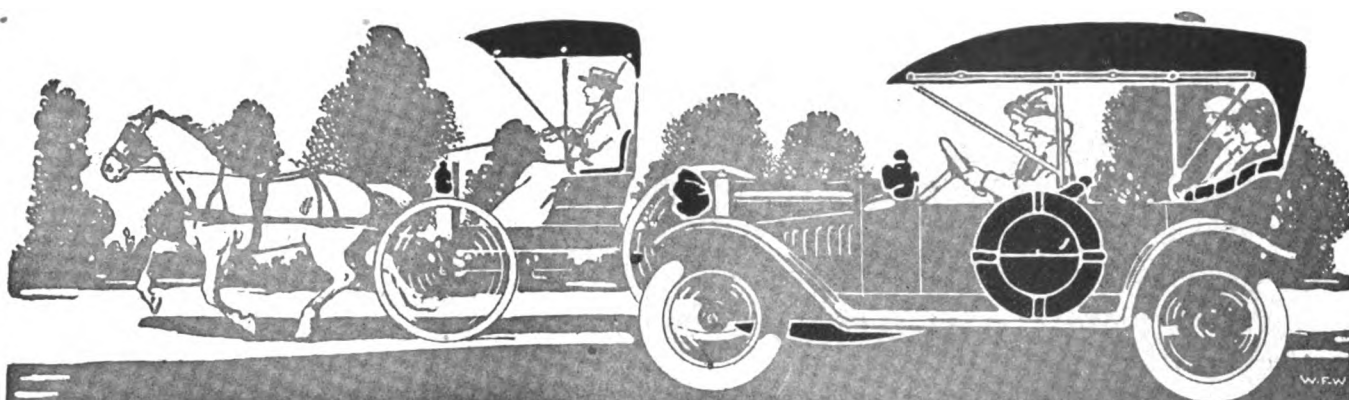

The Leading Leather Substitute For Carriage and Auto Trade

When you need a leather substitute, join the other progressive carriage and automobile manufacturers and select the leading leather substitute—

MERITAS

LEATHER CLOTH

A leather substitute is but a substitute after all—but Meritas leather cloth is made and finished to withstand the hardest wear and handling.

Meritas Leather Cloth is durable, of non-cracking finish and guaranteed perfect by our trademark stamped on the back of every yard. You will like the selection of colors and the lasting finish of this serviceable leather substitute.

Meritas Leather Cloth is made in muslin, duck and drill; dull or glazed; smooth or grained; in black and colors.

Learn more about this leading leather substitute by writing for sample book—sent on request.

Write
for
sample
book of
MERITAS
LEATHER CLOTH
NOW

The Standard Oil Cloth Co., Inc.

320 Broadway, New York

ROME-TURNEY

(TRUCK TYPE)

RADIATOR COOLING SECTIONS

Are Insured for the Life of the Engines

Built of Seamless Copper, Helical Tubes and Heavy Copper Top and Bottom Plates, They Are Practically Indestructible In Normal Service.

Every Rome-Turney Truck-Type Radiator Cooling Section is Sold With This Written Guarantee of Quality. It Is Radiator Insurance in Every Sense.

No. _____

"Radiator Insurance"

ROME-TURNEY
RADIATOR COMPANY
of ROME, NEW YORK

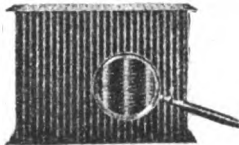

Guarantees

The Seamless Helical Tube Cooling Section Number _____
installed on _____ ton truck, made by _____

FOR THE LIFE OF THE MOTOR NUMBER _____

This guaranty is unreserved, except as against accidental injury or freezing. If the cooling section develops leaks we will repair it free of charge.

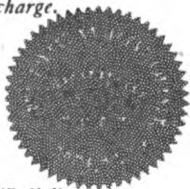

Dated at ROME, N. Y.
this _____ day of _____ 19____

W. L. KINGSLEY, President
BARTON HASBLETON, Vice-President
GEO. W. TURNEY, Treasurer-General Manager
W. L. LYNCH, Secretary

Rome-Turney radiator cooling sections are constructed of seamless copper helical tubes, of which we are exclusive makers, and they are designed to exact proportions. The workmanship is as close as that on the highest priced engine. The radiating results are absolutely certain and endurance is almost unlimited.

Rome-Turney units represent extremely advanced engineering. We have built radiators of all types for 14 years and are specialists in designs developed for truck construction. No better radiators can be built. If this were possible we would build them.

Fullest Information Will Be Supplied at Request.

Correspondence is Invited.

ROME-TURNEY RADIATOR CO.,

ROME, NEW YORK

SHELDON

"The Name Internationally Famous"

Axles and Springs for Vehicles of All Kinds

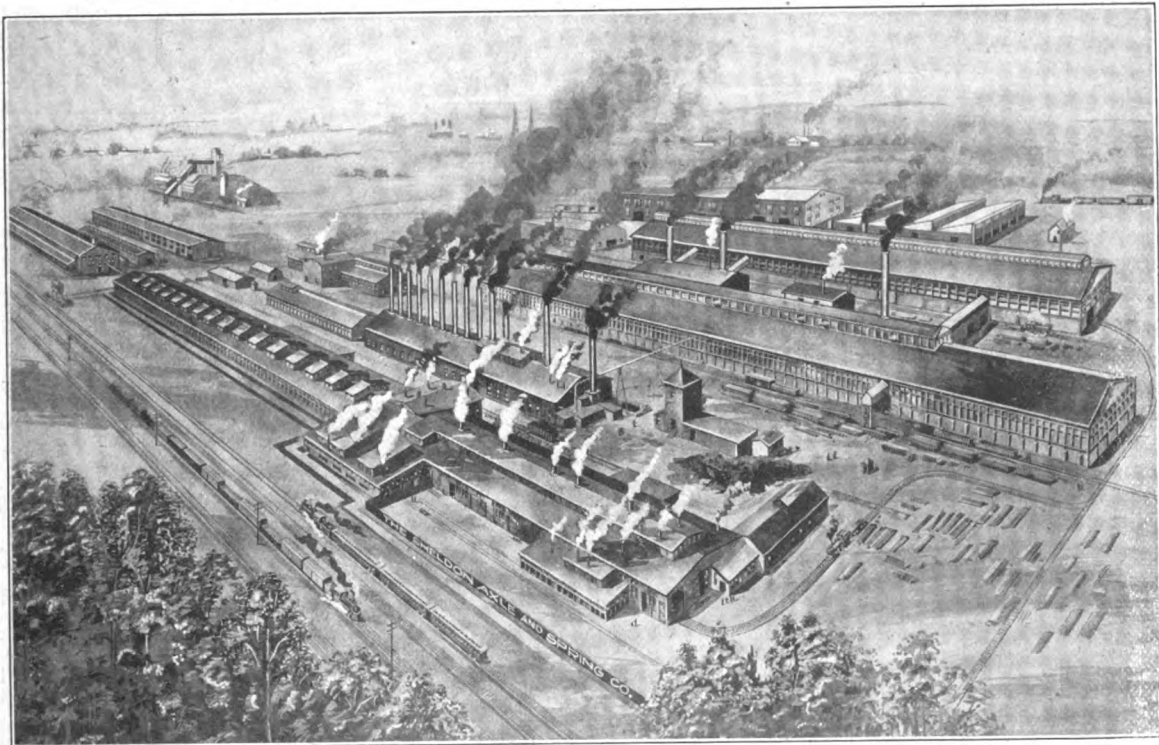

Largest Axle and Spring Works in the World

Sheldon Axle and Spring Company

Wilkes-Barre, Pa., U. S. A.



SEAMLESS TUBING STEEL—BRASS—COPPER

Send Us Your Specifications
for Rush Requirements

MURCOTT-DUDEN CO., Inc.
253 Broadway New York



This Model FA
Hartford
Self Winding
Electric Clock
is only
\$10

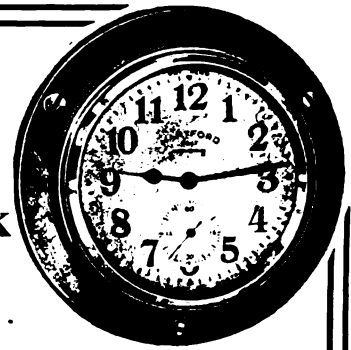

Not only is it wonderfully accurate and dependable, but its construction is marvelously simple.

The Hartford Self Winding Electric Clock operates either from the storage battery or on four No. 6 dry cells. No keys are required. It doesn't have to be taken apart to be wound.

It is immune to the effects of vibration, heat, dust and cold. It tells the right time—all the time.

The Only Absolutely Accurate Electric Clock for Automobiles

The electrical attachment is extremely simple and cannot get out of order.

A high grade electrical clock in every respect—one that dealers can sell with the utmost confidence and motorists can install with perfect satisfaction.

The Hartford Electric Clock is made in two types. Model FA Flush Type. Model XA Extended Type. Either model in all nickle or black with black or silvered dials. Price \$10.

Dealers and jobbers should write us for our attractive selling proposition for the coming year.

Manufactured by

THE HARTFORD CLOCK COMPANY, Inc.
6 Church Street, New York City

Clamps and Wrenches for Lasting Service

For light service.
Capacities, 0 to 12"

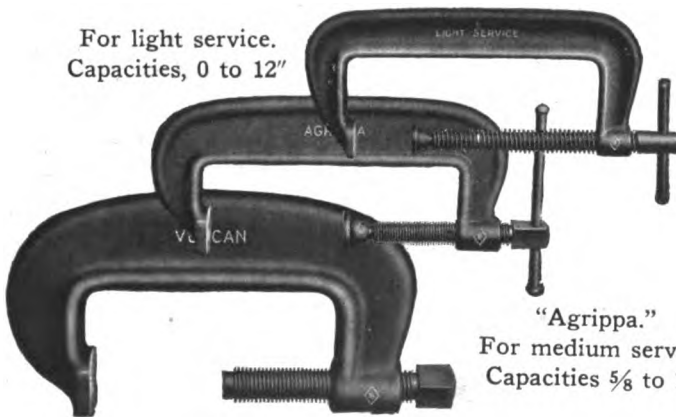

"Agrippa."
For medium service.
Capacities 5/8 to 18"

"Vucan."
For heavy service.
Capacities 1/8 to 12 1/2"

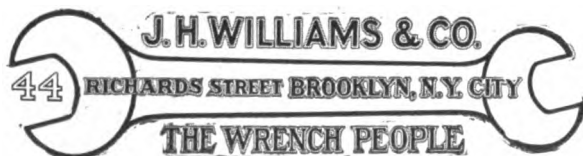

Western Office and Warehouse: 40 So. Clinton Street, Chicago, Ill.



The Hub

INCLUDING Carriage and Wagon Builder and American Vehicle

Vol. LVIII

NEW YORK, OCTOBER, 1916

No. 7

Published Monthly by

THE TRADE NEWS PUBLISHING CO. OF N. Y.

PAUL MORSE RICHARDS, *President* G. A. TANNER, *Secretary and Treasurer*
EDISON BUILDING, COR. ELM AND DUANE STS., NEW YORK

THE HUB, a monthly authoritative journal on all subjects pertaining to the vehicle industry from its engineering and construction viewpoints. It publishes information of live interest to manufacturers of motor vehicles, trailers, carriages, wagons, the accessory trades, repair shops and garages.

Subscription price for the United States, Mexico, Cuba, Porto Rico, Guam, the Philippines, and the Hawaiian Islands, \$2.00; Canada, \$2.50; payable strictly in advance. Single copies, 25 cents. Remittances at risk of subscriber, unless by registered letter, or by draft, check, express or post-office order, payable to the order of THE TRADE NEWS PUBLISHING CO.

For advertising rates apply to the publishers. Advertisements must be acceptable to publishers. Copy for new advertisements must be received by the 25th of the preceding month. All communications must be accompanied by the full name and address of writer.

Entered in the New York Post Office as Second-class Matter

High Cost of Living

The most unsatisfactory feature of the general situation is the general rise in the cost of living, which is unquestionably bearing heavily upon the people of small incomes. There is, perhaps, little comfort to them in reflecting that the conditions are temporary, as they unquestionably are. They are the direct result of the withdrawal of so many men from industry and the enormous consumptive demands of the war. These prices, however, are giving a stimulus to industry which will result in a permanent increase in the supply of all kinds of goods. In Cuba, for instance, there is great activity clearing new lands and bringing them into sugar production. The same is true in all sugar-producing countries, and it requires no prophet to tell that when the beet sugars of Europe come again into the market, prices will be lower than ever before known. The work that is being done for agriculture in this country at the present time gives promise of important results before long. The farmers are increasing their herds, sheep raising is feeling the stimulus of unusual profits, and there are many signs which indicate that the consumer will have an inning later if he can hold out until the time comes.

Stores of Gold

A conference of French and British financial authorities was held at Calais last month, which the prime ministers of both countries attended, and at which arrangements were made for virtually pooling the gold reserves of the Allies; Russia and Italy, it is said, will participate. The Bank of France has already sent large sums of gold to London, pursuant to this and previous conferences. It is a remarkable fact that the Banks of England, France

and Russia all hold more gold at this time than they ever had at any time prior to the war, and the heavy shipments to this country during the last five months have not been reflected in their official statements. This indicates that the governments have had stores of gold not included in the bank reserves, probably, in the case of Great Britain, new gold from the mines.

New York Led All in Tonnage

According to the Statistical Abstract of the United States for 1914, the Port of New York led all other ports in the world in the tonnage of the vessels entered and cleared. The net registered tonnage of vessels entered was 15,767,547, and of vessels cleared was 15,421,394. The next port in order was Hamburg in 1913 with a tonnage of 14,185,000 for vessels entered and 14,440,000 for vessels cleared.

Foreign Trade Increases

The increase in the exports of the United States during the last fiscal year was \$1,576,411,000, and in imports \$541,025,000, as compared with the preceding fiscal year.

Briscoe's Prediction Is 5,000,000 Cars in 1919

Benjamin Briscoe, president of the Briscoe Motor Corp., predicts that by July 1, 1919, there will be 5,000,000 automobiles in use in the United States. Estimating that there are at the present time 2,500,000 cars in use throughout the country and that after deduction of the 1911-made cars which will go out of commission sometime in the course of the present year, there will be added to the number now in use about 900,000. Mr. Briscoe thinks that with the start of 1917 there will be 3,300,000 automobiles in operation.

"For the year 1917," writes Mr. Briscoe, "we would deduct the 1912 production of 400,000 and add 1,100,000 which probably will be the production for 1917—production still being influenced by shortage of material and labor—giving us a total at the end of 1917 of 4,000,000 cars in use. At the end of 1918 deduct the production of 1913 of approximately 500,000 and add 1,500,000, making a net increase of 1,000,000 automobiles in use. Estimating these figures as being approximately correct—and they may vary up 500,000 or down 250,000—there will then be operating in the United States a total number of about 5,000,000 automobiles."

The latest American delivery vans have wire netting sides to the van, and resemble a cross between a motor hearse and a traveling monkey house.—Light Car (London).

Takes a Fall Out of Hotel Men

Douglass Barnes, of New York City, delivered an address at the recent World's Salesmen's Congress at Detroit, which will cause many a hotel man to "sit up and take notice." Among other things, he said:

Former speakers have ably counseled us as to how we should sell things to others. My topic deals with how goods should be sold to us—things that we must buy every day—food, shelter and entertainment.

The hotel, incidentally, is the only business I know of today, of a public character, that does not publish and adhere to any comprehensive schedule.

What would it be like if all other utilities operated upon the same basis? You would buy your railroad ticket, for instance, not by the established tariff, but by the ticket seller's X-ray estimation of your spending capacity: your Pullman, by what a shrewd conductor could shake you down for; menus and price lists being tabooed, the price of a meal would depend largely upon your disposition—or your capacity to out-jockey the waiter.

It is already common knowledge, I believe, that a hotel clerk's value to the house is usually gauged by what he can procure for the rooms in excess of the regular scale.

A prominent magazine writer, a few weeks since, even explained at some length that the modern hotel proprietor has in his private office a neat little statistical table with a column for each room clerk, showing the average price per room each clerk manages to extract—a score card, as it were, of the clerk's batting average.

This is more than amply borne out by the experiences of those who travel constantly. Frequently after refusing to accept the first rate named, after the clerk has already gone on record that that was the only priced room he had in the house, we have afterwards been furnished with a very desirable room at 50 per cent of the rate first quoted, all of which indicates the practice to be very general.

Perhaps this "get-all-you-can" policy which has long been chronic with so many hotels explains why in being roomed by different clerks, as many different rates are imposed.

The other abominable practice of raising the ante upon the late-at-night arrivals is still in vogue. It is nothing more than the old road agents specialty reduced to the fine art of an indoor sport. A smile, and a good thick crust instead of the mask, substitute the more vulgar Colt-45. Instead of a lonely highway, an impatient line waiting to register furnishes a better back-ground for the modern holdup. It is calculated also as being the psychological time for unloading the higher-priced rooms. Nor is this surmise. I have known of men, who, because of the lines they carried, had as little use for a sample room as the devil has for fire extinguishers, being obliged to accept one of these affairs—at the maximum rate when for a certainty the house had any number of moderately-priced rooms vacant. This practice is known as "educating the guest" and is regarded as good salesmanship by many managements. The petty larceny phase of exacting 50 cents or a dollar over the minimum for the small room is the more frequent midnight abuse, however. This pernicious extortion is so well known today that the wise traveler who has learned to put a premium upon self-respect refuses to be bluffed, regardless of the hour or inconvenience, and goes, bag and baggage, to another hotel. It thrives, however, upon the spineless type who

tolerates it and helps the night clerk's showing on receipts.

It was certainly not a modern sage who authored, "Two can sleep as cheaply as one." Evidently, he never played one-night stands double, on the European plan. Occasionally I have heard of instances where no additional charge was made for one's betterhalf, but these are so rare in this age that I associate them with other legends. If there is anything to it, I have often wondered why salesmen have never hit upon the "pass-the-word-along" plan that tramps employ by putting a distinguishing chalk mark upon the doorstep of such havens. Observing this phase of hoteldom, one audaciously extracts 100 per cent more for the second occupant; in another, only 75 per cent is charged with the air of having made a great concession; in others, 50 per cent is graciously conceded; while fewer condescend to 30 per cent.

With the Pullman service, for example, neither the hour of arrival nor the "front" of the passenger has any influence whatever upon the rate. These are plainly scheduled. Again, if two are content to share the same space the same tariff applies.

N. A. C. C. Committees

Following is the personnel of the various committees of the National Automobile Chamber of Commerce for the coming year:

Patents—Chairman, C. C. Hanch, Studebaker Corporation; William H. Van Dervoort, Moline Automobile Co.; Windsor T. White, White Co.; W. C. Leland, Cadillac Motor Car Co.; Howard E. Coffin, Hudson Motor Car Co.

Traffic—Chairman, William E. Metzger, Argo Electric; R. E. Olds, Reo Motor Car Co.; A. I. Philp, Dodge Bros.

Show—Chairman, George Pope; W. C. Leland, Cadillac Motor Car Co.

Legislative—Chairman, H. H. Rice, Waverley Co.; J. Walter Drake, Hupp Motor Car Co.; J. I. Farley, Auburn Automobile Co.

Electric Vehicle—Chairman, H. H. Rice, Waverley Co.; Fred R. White, Baker-R & L Co.; W. C. Anderson, Anderson Electric Car Co.

Commercial Vehicle—Chairman, Windsor T. White, White Co.; Alvan Macauley, Packard Motor Car Co.; H. Kerr Thomas, Pierce-Arrow Motor Car Co.; P. D. Wagoner, General Vehicle Co.; M. L. Pulcher, Federal Motor Truck Co.

Good Roads—Chairman, Roy D. Chapin, Hudson Motor Car Co.; W. E. Metzger, Argo Electric; C. C. Hanch, Studebaker Corporation.

Hand Book—Chairman, Carl H. Pelton, Maxwell Motor Co.; A. I. Philp, Dodge Bros.; A. L. Riker, Locomobile.

Membership—Chairman, Wilfred C. Leland, Cadillac Motor Car Co.; Hugh Chalmers, Chalmers Motor Car Co.; C. W. Churchill, Winton Co.

Canada's Armored Cars

Canada has sent 40 armored cars to the front, together with workshop storage, blacksmith's shop, and scouting cars. Each nickel steel armored car has a mounted machine gun and equipment. The body of the car was designed by Col. W. K. McNaught; one of the features is that the turret is mounted on ball bearings, and allows the machine gun to be moved to any point so as to command every avenue of approach. The cars have front and rear drive, each car carrying two drivers.

Proceedings Forty-fourth Annual Convention

Carriage Builders' National Association

Held in Hotel Gibson, Cincinnati, O., September 26-28

The forty-fourth annual convention of the Carriage Builders' National Association was called to order by President P. E. Ebrenz in the assembly hall of the Hotel Gibson, Cincinnati, O., Tuesday, September 26, 1916, at 10 a. m.

In attendance and enthusiasm it was the best convention that has been held in several years.

Mayor George Putchá welcomed the members to Cincinnati.

In his annual address, President Ebrenz spoke in part as follows:

ADDRESS OF PRESIDENT EBRENZ

We should realize that the present high level of prices in all lines depends entirely upon the continuation of the war—that, with the ending of the war, there must surely take place a complete and far reaching adjustment.

How is all this affecting our own business? We have been confronted with a declining demand on the one hand and a price situation on the other, which, together is making our position difficult. We must admit the fact that our general volume has been reduced during the past four years. What are we going to do to improve our business and take larger part in the general prosperity we hear so much about? That the vehicle business is improving or coming back is, I believe, true. I do not mean to say that the buggy business is coming back immediately to its volume of the past. I do mean to say that I believe it is settling itself upon a firm foundation and that there will be as good or a better buggy business for many years as there has been in the past year. Do you know that some of the best manufacturers in the country have not only produced a normal product this year but have in several instances increased it?

The Federal State Commission states that at the present time there are not more than 10 per cent of our manufacturers who know what it costs to produce their goods. The remaining 90 per cent are pricing their goods arbitrarily—either by guess work or by fixing their prices to conform with the prices of their competitors. A large proportion of our manufacturers are not making the money they should and some perhaps are actually losing money. The purpose of conducting a business is to make money, and the only way to make money is to sell something for more than it costs. The first essential is to know the cost. This association appreciated this fact, and two years ago your executive committee appointed a committee, consisting of several gentlemen who were thoroughly familiar with cost-finding systems. They devoted much time and labor to the subject, held a series of meetings, with the result that they produced a cost system applicable to our business, which has been offered gratis to any of our members who chose to avail themselves of it.

Costs and Efficiency

It is a fact too little realized that an accurate knowledge of costs is fundamentally related to efficiency; more and more concerns are joining the ranks of those who realize the necessity of knowing accurately their cost of manufacturing and selling.

If the manufacturer will look upon a cost system as an investment which he expects to produce for him a fair return in the same manner that an investment in improved machinery would, the objection as to the expense of putting in a cost system is not a valid one. Formerly, the necessity for the determination of true manufacturing cost was not as imperative as it is today. Margins were larger and costs could be ignored except in a general way and a good return still be made on the investment.

It is a fact well understood among business men that the general demoralization in the large number of industries has been caused by those who cut prices, not knowing what their goods actually cost to manufacture, and the cost of selling, which is equally important, is almost wholly lost sight of. A manufacturer who does not know with a close degree of accuracy what it costs him to produce the articles he makes, and what it costs him to sell them, is not in a position to intelligently meet competition and invites business disaster.

We are in a period of high prices, and facing that condition it is folly for any of us not to look the situation squarely in the face, and place a price upon our product that will not alone take care of the increased costs, but which will insure a return commensurate with your investment and ability. A man who has not made headway in his business is more apt to receive criticism instead of sympathy and his credit suffers.

Yesterday there was a meeting held by a number of our members for the purpose of discussing the increases in materials and the general situation. This meeting was harmonious, and indicated that we are now inclined to give out information to each other concerning our business, which is a very healthy sign. Our association compiles statistics as to production, shipments and costs, for the benefit of our members, and instead of trying to keep this information to ourselves individually, we welcome the opportunity to supply the data, knowing that our competitor is doing the same thing, and that these statistics will be of benefit to himself and to our industry.

Now, gentlemen, let us consider the possibilities of our business for a few minutes. The number of automobiles in use continues to increase, but don't forget that every automobile sale does not necessarily mean the killing of a buggy prospect. Many people who now own automobiles never had any real love for the horse, and still others had no way by which horses could be kept and cared for. Such persons would not be prospects for buggies even

though there were no automobiles in the world. The buggy business will not suffer because people of this class buy automobiles.

Buggy Coming Back to Stay

The buggy business is coming back. It is already recovering from the first shock, and, like the bicycle, will always have a fixed and permanent place in the business and pleasure operations of the people. There is no theory about it at all. We have only to consider the figures and, on the mathematical showing, we must realize that such a prediction has a solid foundation upon which to rest.

Considered from a business standpoint, the buggy has come back to stay. It will be staple and always a profitable line to handle. It never has and never will cause the dealer much trouble or anxiety after the sale is made.

In the recent past, dealers have felt afraid of the automobile influence on the buggy business. They have hesitated about keeping up their buggy stocks and going after business aggressively. The buggy business is still profitable and will respond to good merchandising methods as in the past. The field is still fertile and many dealers of the highest class are getting back their old time enthusiasm.

We all recall that a buggy man used to be about as good a salesman as the country produced. It always, even in the boom days of the business, took a good man to sell buggies. Right now the buggy trade needs that old-time salesmanship. It needs good buggy men and it needs the same skill in showroom display it always did. The impress, "the appeal," is everything, almost, in making buggy sales.

A good stock of buggies, a real display, is the first essential. A profitable buggy business cannot be built up on one or two samples for show—positively it cannot—any more than a fruit store can flourish with only one orange or banana on display. The fruit merchant puts loads of his best stuff in the windows, and the whole store is one grand display. He knows the "appeal" must be made—and the good buggy man knows it, too. The buggy display room must be the "real thing"—the "appeal" must be made—but the business can be, and is, being made a success by buggy men who put "pep" into it.

The game is worth while and good, clean money awaits the man who will study the buggy business under present conditions; not as it once was, but as it may be made—now.

Edward F. Trefz, of the Chamber of Commerce of the United States, addressed the convention at length, after which a motion delegating the executive committee to pass on all referendum matters from the Chamber of Commerce was adopted.

Mr. Luth was nominated president for the ensuing year.

President Ebrenz announced the appointment of committees, after which the convention adjourned to the following day.

Report on Publicity

At Wednesday's session, A. M. Ware, chairman of the vehicle trade press committee, in his report said that a noticeable development of the year was that the greatest newspapers in the country were making use of the matter furnished by the committee and that many papers had been inspired to make favorable editorial comments.

There were samples of the posters on exhibition in the hall. A halt had been made in the spring in the progress

of the poster campaign because of the advanced price of paper, although a number of Cincinnati manufacturers had purchased large quantities and made good use of them. The committee urged pushing the campaign in October and November to prepare the trade for early spring buying.

The cost of producing the total quantity of posters, the past year, outside of the drawings, plates, engravings, etc., was \$776.77, and receipts \$765, leaving the poster account overdrawn \$11.77, which will be covered when the posters on hand are sold.

From the date of the convention last year to the present time, the committee expended \$2,459 in publicity work, leaving a balance on hand of the funds set apart during the year for this purpose of \$781. This will be used this fall and winter.

J. H. Redhead, of the National Malleable Castings Co., of Cleveland, addressed the convention on "Standardization." He reviewed at length the benefits to be derived from standardization and the work of the standardization conference held in Cleveland in April in the matter of standardizing axle spindles, axle boxes, wheel hubs and flanges. The result of this conference was published in the September issue of *The Hub*. O. B. Bannister presided at the Cleveland meeting.

Chas. E. Adams, president of the Cleveland Hardware Co., addressed the convention on "Steel Conditions—the Present and Immediate Future." His address will be found elsewhere in this issue of *The Hub*.

Business After the War

Harrison B. Smith spoke on "Business After the War." He said:

It is very generally conceded, I think, that directly after peace is declared there will be at least a temporary slump in business. This depression will be partly due to the uncertainty of the future, and also to the revision downward of prices prevailing during the war. Most all of the manufacturers will have a lot of high priced stock on hand, which they will be unwilling to dispose of at any great concession. There will be some, however, who will not be able to carry the stock, and will have to sell at a loss. This, combined with the uncertainty, will surely depress all markets temporarily. Business, of course, will resume again more normal action, but just how soon, and to what extent, it is hard to say. You will recall how buyers held off their purchases in 1914, and the spring of 1915, when everything pointed to better business and increased profits. The psychological effect of the uncertainty may last over a period much longer than is warranted by conditions.

The railroads have been holding off their necessary purchases of steel till they can buy at more normal prices. The strain on their properties, due to the large business handled, will compel them to enter the market for large supplies. A great many other industries are in the same condition, which will assure at least a fair amount of domestic business for a while. There will also be a great many products for which there will be a demand from abroad, in order to get their industries in full action again. It is often contended that the foreign countries will be in such poverty after the war that they will be unable to buy the supplies for putting their plants on a normal working basis. While many billions are estimated as being spent on the war, this does not really represent as large

an economic waste as it seems. There is very little labor going toward the manufacturing of luxuries which is normally a large economic loss. The people of the countries are buying the bonds except for the comparatively few bought in this country, and will later be taxed to pay themselves back. Everybody not employed in the war is working far beyond his normal energy, and the wealth of the country is not only the money it has in bank, or the trade balance against other countries, but the resources in its lands and the amount of work produced by the population. I therefore cannot see how the countries can be impoverished to the extent of materially impairing

initiative and enthusiasm, which is fortunately the result of a country having been at war.

While I believe that the ingenuity and progressiveness of the modern American business man will always keep the wolf from the door, our hopes of capturing international trade will become past visions unless we can bring labor to realize that it is to their benefit to meet capital half way; that the working man cannot be prosperous without prosperity in business; that unless there is a margin of profit in business sufficient to attract capital, money for investment will seek other fields and other countries.



PROMINENT OFFICIALS OF THE CARRIAGE BUILDERS' NATIONAL ASSOCIATION AND MEMBERS OF THE TRADE PRESS

Top row, left to right—A. M. Ware, Philadelphia; C. E. Adams, Cleveland; G. W. Huston, Cincinnati; G. A. Tanner, New York; H. W. Ferkler, Philadelphia; W. P. Champney, Cleveland; P. P. Hunter, Cincinnati.
Bottom row, left to right—W. A. Sayers, Cincinnati; Homer McDaniel, Cleveland; T. M. Sechler, Moline, Ind.; P. E. Ebrenz, St. Louis; Theodore Luth, Cincinnati; H. C. McLearn, Mt. Vernon, N. Y.; Morris Woodhull, Dayton, O.

their credit, and consequently think they will be able to finance the purchase of the supplies necessary for starting the wheels of industry going again.

When the Real Scramble Will Begin

After the foreign countries have supplied their immediate needs, and have started their factories again, then will come the real scramble for business and trade. Assuming that the foreign countries are again put on a competitive basis of manufacturing, it will then be up to us to be in a state of preparedness. Then men will be back from the war, anxious to push ahead and reestablish themselves in business and trade. They will have that

The argument of the labor unions that there is a limited amount of work to be done, and in order to make it go as far as possible the men must work slowly and demand high wages, is wrong. There is no limit to the amount of work to be done, or the wealth to be created by an industrious and far seeing nation.

The politicians and executive bodies in the country are afraid of the question, so it is up to the business men to teach labor that we can pay them high wages and still make money, but that this can only be done through greater efficiency and industry, and not through arbitrary actions and unreasonable demands.

We have a large balance of trade, millions in our banks; the greatest collection of brilliant men in the world; the Federal Reserve to give currency more elasticity, and large undeveloped resources. With these assets, we have everything before us to make the country successful and prosperous.

There is no reason for pessimism. But we can't sit back and get rich. We will have to work together hard and efficiently. Develop new methods while still being conservative; standardizing those we have, and put a certain amount every year into scientific research work.

SECRETARY-TREASURER'S REPORT

Secretary-treasurer H. C. McLear submitted his annual report for 1915, January 1, 1915, to December 31 of the same year, as follows:

Cash in bank, January 1, 1915.....	\$3,370.39	
Receipts during the year:		
From dues, interest, exhibition and dinner tickets, etc.....	\$8,131.11	
School	1,628.77	
Associate Members Association...	989.00	
	<hr/>	
	\$10,748.88	\$14,119.27

Expenses during the same period:

General and regular.....	\$10,768.62	
Paid trustees of the Technical School	2,236.42	
Deposited in bank, December 31, 1915	1,114.23	14,119.27
Contributions toward the support of the Technical School during 1915 from the following sources:		
Automobile Chamber of Commerce	\$1,500.00	
Interest on bond for \$1,000 belong- ing to the school.....	45.00	
From the correspondence class....	33.77	
C. R. Wilson Body Co., Detroit, Mich.	20.00	
Holbrook Co., New York.....	20.00	
W. F. Stewart Co., Detroit, Mich..	10.00	\$1,628.77

Nine new active members were added to the association roll during the year and 13 associate.

The following deaths of members occurred during the year:

Honorary

William Wallace Wood, Philadelphia, July 24, 1916, aged 69

Active

Joseph O. Schwartz, New Orleans, Sept. 28, 1915, aged 38.
William J. Davis, Moline, Ill., October 23, 1915, aged 51.
C. C. Bradley, Syracuse, January 29, 1916, aged 82.
John P. Staud, Pittsburgh, November 28, 1915, aged 55.
George B. Heylmann, Noblesville, Ind., July 21, 1916, 46.
Walter N. Beecher, Chicago, August 14, 1916, aged 57.

Associate

John Bratsing, Philadelphia, November 26, 1915.
Walter L. Taylor, Philadelphia, March 19, 1916, aged 40.
Jared Maris, College Hill, O., August 22, 1916, aged 86.
Thos. B. Brooks, Newark, N. J., September 1, 1916.

New Officials

The committee to recommend officers for the coming year selected the following and they were formally elected the following day:

For members of the executive committee for three years:
C. R. Crawford, St. Louis, Mo.; Thos. M. Sechler, Moline,

Ill.; P. P. Hunter, Cincinnati, O.; P. E. Ebrenz, St. Louis, Mo.

Member of board of trustees of Technical School:
Daniel T. Wilson, New York City.

Secretary and Treasurer: Henry C. McLear, Mt. Vernon, N. Y.

For vice-president in each state represented in this association: A. H. Ahlbrand, Seymour, Ind.; W. G. Norman, Griffin, Ga.; Clifford L. Barnett, San Francisco, Cal.; E. J. Schlamp, Henderson, Ky.; J. D. Craft, Evansville, Ind.; A. M. Parry, Indianapolis, Ind.; E. M. Galbraith, Cincinnati, O.; J. H. Poste, Columbus, O.; H. A. Crawford, Kalamazoo, Mich.; Clen Perrine, Cincinnati, O.; L. E. Nutt, Moline, Ill.; C. S. Walker, Des Moines, Ia.; H. A. White, High Point, N. C.; Thomas B. Tyson, Carthage, N. C.; J. R. Knight, Franklin, Va.; Geo. H. Babcock, Watertown, N. Y.; M. W. Quinlan, Brookline, Mass.; James H. Birch, Jr., Burlington, N. J.; Frank H. Delker, Henderson, Ky.

Mr. Luth, who was placed in nomination for president at Tuesday's session, was elected to that position by acclamation.

In accepting the office, Mr. Luth said: "I believe that if all the carriage manufacturers of this country would attend these meetings and such exhibits as we have upstairs, they would all feel that their time was very well spent in that attendance. And I feel that they would probably learn more here and that they would probably do better buying here among our exhibitors than they can do by waiting for salesmen to come and call on them in their homes.

"The question of standards is one that should be seriously considered and broadened. I believe there are a good many other lines along which our committee on standardization could work. Mr. Champney and I were talking last night about certain lines of wheels. Our talk led me to believe that fifth wheels ought to be standardized. We all ran out of these wheels this past season, and we couldn't get them from the manufacturers and we had to buy from one another stocks of fifth wheels that we have had for years and used them up, which shows that we can use some things that the other fellow uses. If we would all adopt certain standard things of that kind that go into the making of a standard buggy, we would be better off, especially in times like this, when it is hard to get material. Mr. Adams has told us that it would be harder to get material this coming season than it has even been in the past. Therefore, it seems to me that all of the things produced from that material so far as possible should be standardized. If that should come about and one of us should happen to run out of stock, perhaps we would be able to get it from someone else."

Morris Woodhull, of Dayton, O., a former president of the association, but who retired from the carriage building business five years ago, was present and, being called on for a few remarks, said that Mr. Adams made a very exhaustive review of the commercial and industrial condition at the present time, but that he made one important omission.

"And that omission," said Mr. Woodhull, "was the tremendous power of the labor organizations. You must recognize, you men who employ labor, that labor is absolutely in the saddle. For many, many years, the members of labor organizations stuck to their political convictions and voted the Democratic or the Republican tickets. To

day, the nomination of candidates is based largely on the fact of whether or not they will work for labor. We have seen it in the Ohio legislature. We know something about the Workmen's Compensation Act. I must admit that it was one of the best laws that was ever passed in the state of Ohio or in any other state, and it is pretty successful, and I believe was right in principal, but it never would have been passed by the employer. But, in the future, labor is going to demand those vacations about which Mr. Adams spoke, and labor is going to demand all sorts of privileges, and, as he says, and I entirely agree with him, labor never goes down; it always goes up."

Thursday's session was devoted principally to reports from committees.

Clen Perrine, chairman of the committee on new members, reported that while the total membership had declined three or four, there was an actual increase in membership so far as manufacturers are concerned.

Freight and Classification Committee Report

E. M. Galbraith, chairman of the freight and classification committee, reported the following as the most important items handled during the year:

"The railroads operating from the Ohio river territory to Milwaukee issued a Supplement No. 6 to their Tariff No. 101-J, effective March 5, 1916, proposing to put spring delivery vehicles on a higher carload basis than spring passenger vehicles. This was taken up with the carriers and satisfactorily adjusted.

"On May 1 we called a conference in St. Louis of one representative of the advisory committee and two representatives of the carriage manufacturers, for the purpose of considering various matters of classification, in view of the fact that we had been informed that the entire subject of vehicle ratings and minimums would be up for discussion by the railroads in the near future.

"This conference was a very valuable one to your association, and plans for meeting the threatened change of conditions were carefully formulated.

"Coincident with our activities along the above lines, on June 27 we were advised by the members of the committee on uniform classification that the cooperation and assistance of vehicle manufacturers were desired in the arranging of uniform and satisfactory descriptions, ratings and minimum weights on vehicles, especially buggies and spring delivery wagons, and we therefore arranged that a representative of the Carriage Builders' National Association meet with the National Implement and Vehicle Association and discuss and harmonize our ideas, and then on the same day, if possible, meet with the uniform classification committee, and on August 8 we met with representatives of the National Implement and Vehicle Association and also had the great pleasure of meeting with the official classification committee, at which meeting we discussed at length, descriptions, crating requirements and minimum weight on vehicles in official, southern and western classification territory.

"The opinion was expressed by a number of the manufacturers' representatives that the present crating requirements are unnecessarily burdensome, inasmuch as they require more lumber than is absolutely necessary for the protection of the job, and we received permission from the uniform classification committee to submit photographs and blue prints of such changes as our association can suggest. These are now being prepared for presentation.

"The chairman of the committee on uniform classification has promised to supply us within the next few days, a draft of the proposed vehicle items, showing descriptions and minimum weights suggested by his committee. When these are received they will be carefully examined, and your freight and classification committee will again be doing a work which will be worth to each individual member many times more than the total amount of dues paid into this association.

"The latest work of the committee terminated in Chicago on September 21, at which time we appeared before the official classification committee, with relation to Docket No. 30, Subject No. 212, which proposes to establish crating requirements for two-wheel trailer carts exactly similar to that now required on spring wagons. This is more protection than these carts require and is an unnecessary burden on the manufacturer.

"Subject No. 213 proposed to advance the carload rates on spring wagons from Rule 25 to second class.

"Subject No. 214—the same advance is proposed on road carts and passenger vehicles, which is approximately equivalent to an advance in freight rates of nearly 18 per cent.

"Your committee at first felt that it would be very impressive if some of the manufacturers would appear before this committee and say what they think this advance or any advance means to the carriage industry, but this date was so near to the date of this convention that we considered it practically impossible to secure the presence of the leading manufacturers at that meeting.

"However, I am pleased to report that Mr. Payton advises that it is his opinion that we have prevented the proposed rates from becoming effective.

"We were very much surprised to find that the rating and crating requirements for trailer carts had already been published to become effective November 1. This appears an oversight on the part of your committee, but no other carriage manufacturer that we have been in correspondence with seemed to be aware of this change. This is simply a demonstration of the fact that we have to be very alert in scanning dockets of the various classification committees. Will endeavor to secure quick relief from the trailer item which becomes effective November 1, pending the final decision of the official classification committee on crating requirements for trailer carts."

Report of Statistical Committee

O. B. Bannister, chairman of the statistical committee, reported that the committee had made the following requests from the carriage manufacturers of the United States:

1. What was the total number of horse-drawn vehicles (spring work) produced by you from June 30, 1915, to July 1, 1916?
2. What percentage of your normal product did you make?
3. To what do you attribute the shrinkage or gain in product the past 12 months over the previous 12 months?
4. What is your opinion of the future of the carriage trade?

These requests were sent to 298 companies that were engaged in the manufacture of carriages in a wholesale way in the year 1914-1915. Responses were received from 187, 25 of whom reported they had discontinued business, 164 reporting a total product of 362,202. There were 33 large manufacturers and 26 medium or smaller manufacturers that did not respond to the committee's request. From

such information as the committee could secure, as to the number of sets of axles, number of sets of wheels, and shafts and poles purchased by these 59 manufacturers, it is estimated that their total product was 33,265.

It was estimated upon the same basis that the other 50 manufacturers, to whom the request was sent, who did not respond, produced 5,000 jobs.

From information in possession of the committee, it is considered a conservative estimate that there were at least 25,000 jobs produced by the smaller carriage and wagon manufacturers.

If these estimates are correct, and it is believed that they are substantially so, it would show a total product of new vehicles for the year 1915-1916 of 425,647 jobs.

From further information received in reply to the foregoing inquiries, it appears that the average per cent of normal production varied from 23 per cent in New York state to 93 per cent in Michigan, Indiana standing first in number of jobs reported, Ohio second and Massachusetts last.

Work of Technical School

Instructor Andrew F. Johnson, of the Technical School, reported that the past year was the best in the history of that institution since its establishment in 1888. The school season opened October 25 in the Mechanics Institute, 20 W. 44th street, New York City, with 12 day and 52 evening students.

Four of the day men lived in the city and eight came from Bridgeport, Conn.; Muncie, Ind.; Amesbury, Mass.; Boston, Mass.; Detroit, Mich.; Omaha, Neb.; Elizabeth, N. J.; Fon du Lac, Wis. The day men were all body makers except one and he was a designer. The evening men were all employed during the daytime in the shops in the city. Thirty-five of these men were body makers. Six were general woodworkers. Five were draftsmen. Four were office men. One painter and one trimmer. The average age of the day men was 25; evening, 22.

There were 15 graduates, seven from the day class and eight from the evening class.

During the year eight men completed the correspondence course and were given certificates of graduation. These men were from widely separated localities in the United States and Canada. The average age of these graduates was 29½ years.

The school is becoming better known and more highly valued as the years pass. Its graduates are sought for and it cannot train men fast enough to meet the demand.

Thos. Luth, chairman of the executive committee, reviewed the work and extolled the merits of the various association committees. The committee recommended the continuation of the building of good roads throughout the country, but that special provision be made to build the roads of sufficient width and character to give proper accommodation and protection to the horse-drawn vehicle.

"A new and very serious condition," says the report, "arose during the year in regard to the supply of material entering into the construction of vehicles. Not only has the supply been very short and therefore very difficult to secure, but the prices of material have continually advanced during the season, so that the vehicle builder today is confronted with a proposition that is a very important one and will require the readjustment of vehicle builders' prices. Your committee recommends that the manufacturer urge upon his trade the necessity of placing orders

early, and anticipating their requirements during the winter season, to enable the builder to make a fair estimate of his wants, otherwise the dealers will find themselves unable to secure their wants in time to meet the demands of their trade."

Horse-drawn Vehicle Has a Place

Homer McDaniel addressed the convention on "Why the Accessory Trade Sticks to the Buggy Business." He said: "It is next to impossible, no matter what our ideas or our prejudices may be, to confront an economic evolution. But, the horse-drawn vehicle, from my own experience, has a place. For instance, in the delivery of parcels in a large city. I am myself only incidentally in the accessory trade; I have more to do and spend more time in handling food products and in the distribution of them, than I do in anything else. In our city we have a large market connected with the business, that I actually manage, and I know that you can deliver more packages in a given time within a reasonable radius, with a horse-drawn vehicle, leaving out the matter of expense, than you can with an automobile. The automobile agent or salesman who comes in to see me overlooks the fact that the horse has a degree of intelligence. The automobile has no mind, and therefore you have got to stop it, but a horse will go up to the gate where he is in the habit of going and stop, and while he is stopping the boy is getting the package and getting out. When the boy returns from the house, the horse starts while the boy is getting on. I have tried it out any number of times. Where towns are large and scattered, as towns now are going to be, on account of quick transportation, the only advantage in the delivery of parcels by electric or power wagons is the fact that you have so much outlying territory, and you can save some time in going to and from it, but you can't deliver your parcels as cheaply in that way as you can from a horse-drawn vehicle. That's one reason why I think the horse-drawn vehicle has a useful place.

"Another reason that I have faith in the future of the horse-drawn vehicle is the fact that probably 65 per cent of the value of the automobile is in the road. The automobile, without a good street, without a good road, is as helpless under most conditions as the locomotive without a rail. And the building and lacing of this country with such roads as will bring about the coming of the automobile and the disappearance of the horse-drawn vehicle is a long, long way in the future. Of course, if you figure what the horse-drawn vehicle industry would be today, in the absence of the power vehicle, and taking into consideration the great growth of this country in the last ten years—your figures would be very much against the situation. But if I had a large plant today I wouldn't abandon the buggy business, but I would keep my eye on the weather vane and look for opportunities where I could make use of my factory and my facilities for manufacturing, in connection with the power wagon, in some way. I would do that in order to avoid the cutting down of my product."

Looking Backward

Following Mr. McDaniel's address, Thomas M. Sechler spoke upon the past. He said:

"When the president gave me the subject of "Looking Backward" on which to talk, some suggestion was made as to the amount of time to be occupied, but nothing was said as to how far backward we were to look; whether

we were to look back to the delivery wagons which brought food supplies to Captain Noah for victualing the crew and passengers of his floating menageries during its tour of the world which ended by running aground at Mount Ararat, or skip over the ages to 1755, the date of the building of the one-hoss shay described by Holmes, which lasted 100 years and then went to pieces all at once (which, as is now known, was built at Merrimac, Mass., by an ancestor and predecessor in trade of a present active and useful member of this association), or to the birth of this association, or still later to the time when the factory-made buggy was first introduced to the American rider.

"My re-entry into the carriage trade dates a little later than the birth of this organization, as when it was organized I, with five other misguided Ohioans, was endeavoring to get rich quick making iron in Tennessee, and after spending eight good years of life together with all our capital (and some of our creditors') we came back to the Ohio River valley, where the speaker and his father resumed the buggy business after 33 years engaged in other pursuits. This was in 1877.

"I believe the first cheap buggy was made in Cincinnati about 1874. Others soon followed in the same business, so that when we started there were a half dozen already in the business, two starting the same year as we did. Before this time the pioneer manufacturer had failed in business, settling with his creditors at 20 cents on the dollar. His means were not entirely exhausted by this settlement, as indicated by his answer to a salesman who expressed a fear that he might not be able to continue in business as supply houses would now want cash with his orders. He assured the salesman there would be no difficulty in going on, as he had \$40,000 in government bonds in his safe. Some indignation was felt by supply houses who had furnished him with goods, and one of these houses evidenced its dissatisfaction by advertising in the daily papers that it did not want any more dealings with manufacturers of shyster buggies. In later years, when the quality of Cincinnati buggies and their manufacturers had improved, these same houses wanted the buggy trade and got some of it. Only a few of Cincinnati's carriage makers turned out work like the earliest manufacturer; but they gave Cincinnati buggies a bad name which took many years of good work to overcome.

"The majority of the early manufacturers prospered, made money rapidly, but unfortunately many could not keep a good thing to themselves, but had to boast of their profits, whereby they encouraged others to embark in the business, which soon was overdone, notwithstanding many of the late adventurers in the trade failed. In those days as well as later, few manufacturers really knew what their work cost; and with the ambition to furnish something just a little better than the other fellow, many buggies were furnished of a high quality and low price, which, it would seem, a ten-year-old boy should have known, could only result in a loss. I remember one manufacturer who flourished for a brief time, furnishing a buggy with top all leather, including side curtains, with upholstering and painting which would have seemed good to Brewster of New York, with the highest quality of springs and axles, B grade wheels, all for \$50, with material costing more than it does today. As the years passed, manufacturers increasing in numbers and profits diminishing, a time came when all realized that they must

get together and agree on a standard of quality and a higher price for their goods.

"Of the carriage manufacturers who were already in the business when the Sechlers began in 1877, only one is still in the harness, W. A. Sayers, of Sayers & Scoville; and of those who have ceased making buggies I believe J. W. Fisher, of the Emerson & Fisher Co., is the only one living in Cincinnati who was in business in 1880 or before. Spring Grove Cemetery now holds many who in their day were giants in the vehicle industry."

Chicago was selected as the next meeting place of the convention, Richmond Va. being a close second, after which the convention adjourned.

The Banquet

The annual dinner of the association was held Thursday evening at the Hotel Gilson, P. E. Ebrenz, the retiring president, acting as toastmaster.

Honorable Nicholas Longworth spoke on "Industrial Conditions Present and Future," and Dr. Wm. Hammond Parker on "The Place of the Business Man in Modern Society."

South America Buying American Cars

That American-made motor cars are eagerly sought after by residents of South America is the report brought back by Thomas M. Kirker, export representative of the Chalmers Motor Co., who has just returned from a six months' tour through Latin-American countries.

Mr. Kirker sailed from New York early in April and toured through sections of Brazil, Uruguay and the Argentine Republic and effected several important dealer connections.

"Having been absent from South America for several years, the condition that struck me most forcibly was the complete reversal of the former South American attitude toward cars made in the United States," said Mr. Kirker.

"Until recently, European cars outsold Yankee machines by a wide margin. American built cars were considered incapable of standing up on the crude country roads. But this idea has been thoroughly eradicated from their minds by the sturdy performance of even the cheaper cars of American construction. Today there are between 500 and 1,000 cars of European make standing unsold in the warehouses while Yankee cars are selling like the proverbial hot cakes.

"Scarcity of ships and high freight rates are playing havoc with an otherwise bumper crop of sales in South America. Summing up the high cost of freight charges, insurance, boxing and import duties, it means an advance of from 40 to 50 per cent over the American list price of the car if the dealer is to make a fair profit. Scores of German ships are interned in the harbors of Rio de Janeiro, Buenos Aires and other ports and will remain there until the end of the war. Meanwhile, the only vessels in commission are a few British boats. It is assuredly up to the United States government and American merchants to strike while the iron is hot. The need of a protected American merchant marine was never more apparent.

"An example of high freight tariffs is to be found in Brazil. Coffee sells in Brazil at \$1 the bag, but it costs \$2 per bag to transport it to New York. Among the other important shipments now being made from Brazil are great quantities of manganese ore. About 15,000 tons of manganese is shipped weekly from Brazil ports. At the

present time, Germany alone owes Brazil some \$7,000,000 for coffee, crude rubber, ores and other products shipped just before the war.

"In Uruguay a six months drought which destroyed crops and brought heavy damage in its wake, has caused a temporary setback. Cattle and sheep raising, two of the most important industries, suffered from the lack of grazing facilities during the long continued spell of dry weather. The cattlemen and ranch owners are just getting on their feet at the present time.

"I found the most prosperous conditions in the Argentine Republic, with Buenos Aires especially active. Cattle are being shipped in great quantities to England and are bringing war time prices. Practically all the automobile dealers selling American cars are making excellent progress. J. F. Macadam & Co., who have taken on the Chalmers line, have ordered a big consignment shipped them immediately for the big spring and summer trade. Owners of big estancias in the Argentine are finding the motor car a good investment for ranch work. They are buying cars in half dozen lots for the use of their foremen and overseers.

"Undoubtedly the action of the National City Bank of New York in establishing branches throughout South America is responsible for the stimulation in trade with the United States. The National City Bank now has branches in Rio de Janeiro, Sao Paulo, Santos, Montevideo, Buenos Aires and is about to open another in Santiago. All branches are handling a big volume of business. The Guaranty Trust Co. has its investigators on the ground, also, in preparation for going after a share of the profits. Intelligent co-operation between the banking interests of North and South America has at last been established and prosperity awaits the coming of American ships to transport the goods between ports."

According to Mr. Kirker all vessels running to South American points are shrouded in darkness at the present time. Port hole windows are painted black and even masthead lights extinguished. A sharp lookout is maintained at all times for German submarines and raiders. The Vestris, on which he traveled, was twice stopped by British men-of-war, the officers taking on mail and carefully examining the passenger list.

Imitation Leather a Bone of Contention in Australia

In view of the numerous discussions the past year between the tanners and the makers of imitation leather, the following from the Australasian Saddler and Harness Maker is interesting reading:

"Complaining that a substitute for leather, known as 'leather cloth,' was being imported into Australia in large quantities, and advertised for sale in a way that might convince buyers that it was genuine leather, representatives of the master tanners asked the Minister for Customs (Mr. Tudor) on July 19 to say that the article should pay duty as a substitute for leather. Mr. Tudor, in reply, said that the difficulty could easily be overcome by Parliament. At present, however, once the material came into Australia, he could not exercise any control over the way in which it was advertised. He promised to consider the point raised by the deputation.

"A deputation of carriage and wagon builders subsequently waited upon the Minister to oppose the request

of the tanners, which, if acceded to, would, they pointed out, mean a duty of twopence per square foot. The coach builders informed Mr. Tudor there was no possibility of the material such as duck, which they used extensively, being sold as an imitation of leather; as a matter of fact, the two materials were distinct. They supported the government's policy of protection, but to impose a heavy duty on leather cloth and duck would, they considered, penalize the coach building trade without producing any compensating benefit. Mr. Tudor promised to consider the question from both aspects.

"Mr. Zwar, president of the Master Tanners' Federation, in an interview with representatives of this journal, stated that coach builders are under a misapprehension in supposing that his association is desirous of interfering in any way with the importation or sale of duck as used by coach builders. The material aimed at was that used by furniture makers, which was being imposed upon the public as real leather under such names as French chase leather, moroccoline leather, etc. Numerous instances were occurring of these imitations being advertised and accepted by the public as real leather. This they considered a fraudulent practice, and the object of the deputation was to have it dealt with as such."

Smith Form-A-Truck Takes License Under Cook Patent

The Smith Form-A-Truck Co., Chicago, has taken out a license from the Redden Motor Truck Co., New York City, to manufacture converted trucks from touring cars, under the Cook patent, controlled by the Redden company. The Smith company has up to the present converted Ford touring cars into delivery vehicles, having as its patent in this work No. 1,147,131, granted to W. P. Wynne, July 20, 1915, and applied for June 29, 1914. The Redden company controls patent No. 1,180,475 granted to A. E. Cook and T. Van Tuyl, April 25, 1916. It was applied for under date of December 17, 1910.

The Smith Form-A-Truck Co. will continue manufacture of apparatus for converting Ford touring cars into delivery wagons as heretofore, but will do so by payment of royalty on the Cook patent. The contract between the Redden and Smith firms is apparently based on the validity of this patent. The Cook patent, claim No. 32, reads:

"The combination with an automobile of a pair of tractor wheels, a frame supported thereon and affording means to elevate the rear end of the automobile thereon, means on said frame for rigidly engaging the rear end of the automobile thereon, means supporting the front end of the frame on and securing the same to the front end of the automobile, and driving connections between the tractor wheels and the power plant of the automobile."

St. Louis Concern to Build Mail Wagon Bodies

The Commercial Auto Body Co., St. Louis, which manufactures commercial bodies for Ford cars, has been awarded a contract by the United States Postal Department at Washington for government mail wagons. The first order under the contract went to Nashville, Tenn. The cars under specification must be on Ford chassis with screened sides. Between 20 and 30 body builders throughout the United States competed for the big contract, which covers all new mail wagons to be ordered by the government up to June 30, 1917.

Art and the Motor Car

By William B. Stout*

Art is the science of eye-appeal; the appearance-basis of attractiveness. If one builds into a commercial product an appeal to the eye, he establishes the first point of salesmanship, which is impression.

The designing of a motor car is no longer a task for the engineer alone. There was a day when it was merely a mechanism for traveling from place to place, a machine on which seats were mounted that one might enjoy the sensation of swift travel and novelty of mechanical progress. Today the sensation is old and the novelty become the usual.

With the world's acceptance of the motor vehicle and the perfection of car machinery, a new thing was needed to carry appeal further than mere mechanical construction. Comfort and performance stunts have been made a basis of sales. Freak demonstrations and misleading economy tests were tried and succeeded in attracting. Only recently has the value of eye-appeal been recognized, and art even considered in relation to motor vehicles.

The motor car today is a part of the home equipment; standing at the door it reflects the personality and the taste of the home within. Style has come to the motor car.

Reliability is the easiest thing to design into the present-day automobile. Any modern motor car will travel from New York to San Francisco with a satisfactory degree of reliability, and some of the cheap cars with greater mileage per day than the heavy weight, more expensive constructions. The difference then between one car and another, after a certain ultra-cheap class is passed, is in passenger comfort and the self-respect of ownership. This self-respect or pride-value depends upon the authority of the design, and the degree of art involved in its make-up. The art of car building is thus resolving itself more and more into a studio task.

If a car is designed for a certain excellence or standard of mechanical performance, its body lines must be so disposed as to proclaim and suggest that performance. If a car is designed primarily for comfort; the art lines should suggest comfort.

There are certain definite rules and principles of art which have been applied rarely in car design. They were not made use of until a few years ago. Even yet few companies employ artists on their engineering staff. The day will come when bodies will be designed by artists of national reputation spending all their study to make the bodies express by their lines, contours, and arrangement, the individuality and performance the car possesses. If the body backs up in its appeal the statements of the advertising, and the performance and life of the car back up the appearance, the car will be a success, and the marketing of it accomplished along the lines of least resistance and cost. Many a firm today, spending thousands of dollars a year in advertising a body design on a good chassis, might save much by spending a small amount on the hire of an artist experienced in body work. There is a real commercial value in a unique design of car. This has been lost sight of by many manufacturers. It is the advertising value of very car running.

All cars look alike to most people, merely because the makers have followed each other and made the cars look

alike. When one car or another goes by, the public does not distinguish it from the rest. One might hang a sign from end to end to proclaim the make, but the owner would not allow it. If the design be original so that even the man in the street names it as it passes, the car itself is a sign as long as its wheelbase and as insistent as its appearance.

Rules of Appeal in Body Design

The rules of appeal in body design are not intricate but very easily understood. All of the principles are, of course, not treated in this paper, nor can their application to individual requirements be detailed for different cars. The main ideas can, however, be outlined. One generally speaks of the "lines" of a car. It is true a car has lines but they are not the greatest attraction basis of design. We

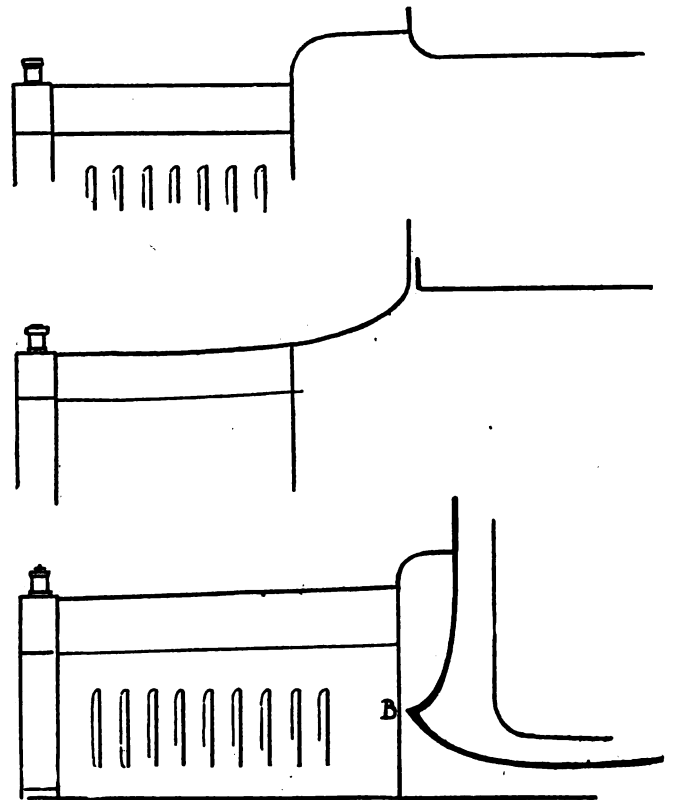

Fig. 1—Upper Hood and cowl with break between them. Fig. 2—Middle—Cowl and body lines growing out of hood lines. Fig. 3—Pointed door or body hook just back of hood.

speak of the human figure or face as having lines, but the profile of the face, for example, is not the most appealing view. Too often the profile of a straight side-view of a car is laid out on the board quarter or half size and the art "lines" judged from this view. This is a view never had by the passer-by and if it were possible to have it there would be no life or action in it, and hence no appeal. All appeal to the beauty sense is by suggestion or implication. Mere lines cannot suggest to nearly as great an extent as masses and edges of shadows can. With the shadows should be included the reflections, which furnish new suggestive edges leading on the subconscious reasoning which gives us our final appeal-decision. This is why a newly finished, highly polished body presents such an extreme appeal, compared with the same car finished dull, unless the car has been designed primarily for dull finish by having contours which make up for the lack of reflection-suggestion.

Types of bodies built a few years ago have lost their

*Consulting engineer, Scripps-Booth Co. Paper presented at meeting of Mid-West Section of S. A. E.

appeal because they were not based on correct principles of art. In nature one thing grows from another, like the branches from a tree trunk, and the twigs from the branches. The newer stream-line bodies aim at this principle in having lines continuous from front to rear with no break, one growing out of the other, but these are pleasing only to the extent that other principles as well are followed. Fig. 1 shows a hood and cowl with a definite break between these parts—a reverse curve which, to look right, would necessitate a hood of different color from that of the cowl and body, to give a reason for the break.

The sketch in Fig. 2 shows the cowl and body lines growing out of the hood lines, as introduced first in this country by the Hudson. I believe, this being one art reason for the great appeal of its body design. The limousine top in this make of car did not look like an attachment or a box seat on a touring car, but, by being continuous in line with the lower design, as part and parcel of and integral with the lower section. This idea of line continuity is one of the greatest problems in the stream-line, curved-top bodies.

Suggestive Lines

We have learned, however, that shadows and reflections are more important than mere lines, and that one must grow from another or from a focusing curve. It is admitted generally that horizontal lines suggest speed and vertical lines stability. This is not true unless the eye hit the right part of the design first. To suggest speed the eye must first alight on the front end of the car and then travel back. Horizontal lines, once the eye is sent to the front end, will help to carry it back, and for this purpose are necessary, but they are useless unless the eye starts at the right place. This illustrates the reason for the nicked radiator or unusual fender arrangements in front on several cars. The Oakland has used the prominent radiator feature for some years, while the Paige in the newer models gains front-end attention by an unusual front shape and fender splash. Packard and Hudson gain attention by unusual radiator caps; the result is the same.

Vertical lines on a car indicate stability only if the eye travels upward from the bottom. One of the reasons for the charm of the pointed door or body hook just back of the hood, as used on coupe and limousine models of prominent makes, is that this accent allows it to travel up and back. A curve to the roof, leading up and back also adds to the speed feeling and appeal of the design. A car with a flat roof and a big ventilator or railing on top looks unstable, rather than sturdy, even though the vertical lines are made more insistent.

Impressions from Proportions

The sense of power in a car can be suggested in two ways; first by the proportion of hood length to the rest of the car, and second by hood height compared to body-sill height:

Body width gives the impression and fact of roominess, while height from the ground suggests stability. Length gives the idea of ability to hold the road at speed, provided the mass of the body's design is carried up front.

Many cars fail in appeal by being too high in proportion to their width. This is sometimes due to frame necessities when a straight frame is used, and sometimes to mechanism carried too high. Cubical dimensions of the body give one a sense of weight or lightness in relation to the

car, and by suggestion of operating expense appeal or repel. To look roomy a car must appear wide in proportion to its depth.

The mass of the running gear, the heavy look of the wheels, etc., suggest comfort. Big wire wheels of red or white denote luxurious riding, though they may ride no more easily.

A great deal of the pleasure of riding is marred by uncomfortable seats. Luxury in cushioning is to be sought, and high curved backs deeply tufted add to comfort, as well as appeal to the eye.

Colors

The final appeal of exterior design is obtained by color and finish and this will depend largely on the experience of the buyer. Black brings out lines and reflections and hides shadows. White emphasizes mass and kills color. Strong colors do not appear well in combination with white, except in small spots or accents, or in striping. Black is a good color for a car of beautiful outline. White is preferable for a car of mediocre outline and gives a sense of largeness. This applies also to tones and colors between white and black. There is a color which best fits a given car. Manufacturing reasons, however, hinder the search for this ideal.

Eventually color will be chosen by the buyer for utilitarian reasons. A color that shows dust and dirt least will be preferred. This points to lighter colors, as black is hardest of all to keep clean, though the easiest to put on in manufacture.

A small vehicle needs more careful finish and appointment than a large one to obtain its measure of road respect. A big limousine obtains its road authority through its mass. A small car must obtain this through insistent appearance. Better finish and trimming almost to the point of flashiness are needed in a light car. What would be bad taste or poor art on a big vehicle becomes good taste on a light car for this reason. Enameled leather upholstery and a quilted dash might look out of place on a big car, but they are quite the things on small construction.

Conclusion

The car of the future will be designed with art lines to suggest the action of its mechanism. It will take every advantage of art knowledge to build up an appeal consistent with its mechanical performance. Speed, power, comfort, luxury, safety and economy will be suggested by appearance, by following art rules as faithfully as engineering rules are followed in the shop.

The automobile for tomorrow is the artist's opportunity.

Trailer Builders Form Association

Fifteen trailer manufacturers met in Detroit, Mich., October 10, and formed a permanent organization to be styled the Trailer Manufacturers' Association of America. It contemplates a model trailer ordinance and other legislation and publicity. The officers are: President, C. A. Geiger, president Troy Wagon Works, Troy, O.; vice-president, Miss K. Gleason, Rochester Trailer Co., East Rochester, N. Y.; secretary-treasurer, J. C. Endebrook, Sechler Co., Cincinnati. The temporary chairman was C. W. Shipley, of the Sechler Co. A. W. Keesler, Watson Wagon Co., Canastota, N. Y., acted as temporary president. An executive committee of four was named.

Efficiency in Cooling Systems for Motor Trucks

Scientific Design and Quality Essential for Simplicity and Adequate Effectiveness in General Use

Efficiency is an essential in the cooling system for engines in power vehicles of any sort, and though it may appear a simple matter, it is nevertheless difficult to obtain, because of the extreme variance of operating conditions. The usual means adopted is the circulating of water through jackets around the cylinder walls, valve chambers and other portions of the engine subject to high temperatures from combustion of fuel. A full understanding of the work required of a cooling system is had by but few. Those who have to do with the operation of motor trucks, and other types of power vehicles, realize that the function of the cooling system is to safeguard the engine, and aside from this knowledge little attention appears to be given to a vital auxiliary of the power plant.

Only a small proportion of the internal combustion engines are built without water jackets. The frequency of explosions varies with the type of engines, a two-cycle type having an explosion in each cylinder at each revolution, and a four-cycle type an explosion every two revolutions. A four-cycle motor, if driven at, say, 1,500 revolutions per minute, which is comparatively slow for a pleasure car motor, but fast for the heavier truck types, would produce 750 explosions per minute, or $12\frac{1}{2}$ per second, which, in an engine operating under normal conditions, would likely produce a temperature of approximately 3,000 deg. F. or higher, during the explosion stroke.

It is apparent that such a temperature would speedily destroy the motor if it was not diffused, or carried off through some cooling medium. Water will very quickly absorb heat, and if engine cylinders are water-jacketed and contain a sufficient volume of water so that it will not boil from the temperature, the heat will be absorbed and the cylinder walls kept cool enough to prevent warping and cracking. Efficient cooling will maintain the cylinder walls at a temperature of probably 700 deg. As it is not practical to so equip vehicles as to carry a large enough supply of water to perform the function of cooling, without circulation, the familiar types of water cooling radiators have become a necessary part of every motor truck, and a most efficient type of such radiator is an adjunct much sought after. These radiators are intended to reduce the temperature of the water to a point slightly less than boiling when an engine is being driven to its maximum capacity. Radiation is promoted by creating a very rapid circulation of air through the cooling units of the radiators, which is accomplished by the use of fans, as the movement of the vehicle is not fast enough to afford a velocity sufficient for this purpose, and to adequately cool the water.

Builders of motors aim to accomplish two results—maintain the temperature of the motor as high as possible and yet not affect the lubrication of the cylinders, etc., nor dissipate the water from the cooling system, and to

draw fuel into the cylinders at as low a temperature as may be practical, in order to maintain the temperature of the valves at as low a point and to obtain the greatest degree of expansion in the combustion chamber as possible. In the field of pleasure car manufacture there is more liberty in the matter of design, perhaps, than is permissible in the motor truck field. The heavier type of engine, and the conditions under which it operates, make necessary the most efficient type of cooling system obtainable for trucks and commercial vehicles generally.

Some details in line with a proposed specification for an ideal motor truck, as brought out at a recent meeting of the Truck Standards Division of the S. A. E., are of pertinent interest, in view of the fact that, in drafting a model specification, particular attention was given the system of cooling to be used.

The proposed specification referred to is to be taken only as a basis from which to build up an acceptable and ideal model of motor truck. We have extracted the para-

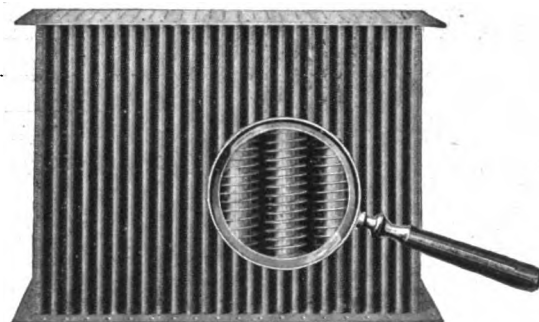

graphs bearing on cooling systems, which read as follows:

"Cooling System—Water cooling must be used, with forced circulation by centrifugal pump, which must be of a design to permit thermo-syphon circulation in event of pump failure. Radiator must be of the vertical individually finned tube type, with detachable upper and lower tanks. All radiators must be interchangeable and constructed as per drawing. Radiators must be flexibly mounted, to prevent strains from any frame distortion. A drain-cock which will drain all the water from the entire cooling system must be fitted in a location where a bucket can be readily placed directly beneath the drain. This drain-cock must have a clear bore of at least $\frac{3}{8}$ in., and must be fitted with a spring-snap lock to hold it in the closed position. All suction hose connections must be provided with means to prevent collapsing. Belt driven fan shall be used with a 28-deg. endless V belt of $1\frac{1}{4}$ in. width, and means of belt adjustment must be provided. A radiator guard must be furnished, in accordance with drawing."

When the water is circulated by means of the pump, and a stated volume forced through the system regularly, it has been assumed by some that because of the rapidity of circulation a constant temperature is maintained, but the generation of heat takes place so rapidly that it is not so well absorbed, and without an increase of the radiator surface, there is no greater dissipation, except from the amount of air drawn through the cooler by the fan. The radiation from the ordinary forward movement of a motor truck, as respects the amount of air drawn through the

form, or appearance of the radiator design is a non-essential, in so far as its actual cooling qualities are concerned.

Types of Radiators

The types of radiators are usually defined by the manner of constructing the cooling section, and are extremely numerous, but they may be classified to be either tubular or cellular. The tubular may be constructed of round, square or flattened tube and the tube may be smooth or finned or gilled, although the flat tube is comparatively small section. The cellular types may be a number of short lengths of round or square tube slightly separated vertically between the rows of tube and with the spaces between the tube ends closed with solder; or the cells may be made of strips of thin sheet brass or copper that are formed so that when the edges are soldered there are small water spaces between the walls and cells through which the air circulates, so that there is large cooling area. There are different methods of forming the metal from which the cores are made, but the main purpose is to make the water spaces very thin and to expose large surface areas, so that the heat may be radiated from the water very quickly. The more rapidly the water is cooled the smaller the volume may be and the less the weight.

The volume of water required for a circulating system may be considerably smaller than that which would be necessary for a thermosyphon or gravity system, and the former is more positive because the pump will force the water through the jackets even when the level is considerably lowered. The thermosyphon circulation does not require a pump and is less complicated and for that reason does not need the same degree of attention, though a thermosyphon radiator must be approximately 25 per cent larger than one for pump circulation.

Motor truck radiators are an entirely different proposition than those of pleasure cars, where appearance and finish count for so much. The slow speed of the truck, driven in traffic centers, and the weight of the car and load, result in an engine always hotter than in the pleasure car, owing chiefly to lack of radiating air influence upon the cooling unit. Truck radiators are sometimes built with heavy top and bottom tanks, and the case made of heavy metal, with side tanks of cast or pressed steel, so designed that the cooling sections can be secured in them by gaskets and bolts or cap screws. With this type, the cooling section, should it become damaged, can be removed and another substituted without a deal of labor or trouble, and the damaged parts repaired.

A number of manufacturers mount the radiators upon trunions, or guides, with springs, to absorb the stress and strains, or chassis distortion, but because of the weight of the radiators when filled with water, some prefer to mount them on supports the full width of the frame, which is believed by radiator builders to be the best or safest construction.

It is, of course, a well known fact that heating water ordinarily causes precipitation of organisms in it, and there are possibilities of scale from the water being carried into the tank at the top, which will settle and accumulate and fill the passages to the radiator, unless these are large enough to insure free flowage. The larger the water passages the less likelihood of their becoming clogged or obstructed. The bottom tank should be large enough to receive the precipitation and retain it. In some cases both top and bottom tanks are finned to promote radiation.

The importance of a properly efficient radiator presents

No. _____

"Radiator Insurance"

**ROME-TURNEY
RADIATOR COMPANY**
of ROME, NEW YORK

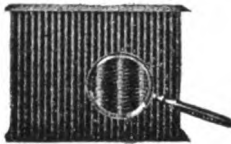

Guarantees

The Seamless Helical Tube Cooling Section Number _____
installed on _____ ton truck, made by _____

FOR THE LIFE OF THE MOTOR NUMBER _____
This guaranty is unreserved, except as against accidental injury
or freezing. If the cooling section develops leaks we will repair
it free of charge.

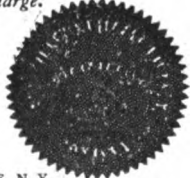

Dated at ROME, N. Y.
this _____ day of _____ 19____

W. L. KINGSLEY, President
BARTON HASELTON, Vice-President
Geo. W. TURNEY, Treasurer-General Manager
W. L. LYNCH, Secretary

cooling unit, is practically negligible, and the fan is depended upon to perform this duty.

It has been figured out that, of the heat generated by an engine, from 50 to 53 per cent is radiated by the cooling system, from 15 to 18 per cent is dissipated by the exhaust, from 15 to 18 per cent is converted into power. The heat losses are known to vary with the degree of cylinder compression and engine speed, but there is no principle or rule by which the variance can be determined.

A realization that radiators are not usually designed to meet the specific requirements of each engine, or, in other words, built to provide the utmost efficiency of cooling for the motor upon which they may be installed, furnishes cause for wonderment at the generally satisfactory results which have been attained. It may be said here, that the

the need for scientific design and construction, as much as in engine building, and in the case of scientifically built radiators, care is taken to provide efficiency in the factors mentioned. Quality construction requires not only high grade material, but proportions, and careful workmanship, that produce satisfactory operation of every function. While not all truck radiators are specially designed for truck service, and though results accomplished seem in many cases to be eminently satisfactory, it is of particular interest to car builders to know that there are concerns that specialize on coolers intended for service only on motor trucks. It is said that the factory of the Rome-Turney Radiator Co., Rome, N. Y., is the largest truck radiator factory in America, and it claims to produce a large part of all radiators built purposely for vehicles constructed for freight carrying.

For 14 years this company has been engaged in the manufacture of radiators, producing practically all types that are used for both pleasure and commercial vehicles, but because of exclusively controlling the production of the helical tube type, it is not paying as much attention to the manufacture of pleasure car radiators as previously, and is specializing in helical tube and aeroplane radiators of different designs. The company has a large and extremely well equipped plant and employs workers who have had exceptional training in radiator building. These men are expert and have every facility for producing high quality coolers. The company is closely affiliated with the Rome Brass and Copper Co., which is a very large manufacturer of these metals, and is in a position to obtain all materials whenever needed and can make deliveries to meet orders without possibility of delay. This has proven to be an exceptional advantage for its customers.

The helical tube radiator is given that name from the fact that the cooling section is constructed of vertical copper tube that is encircled by a helical copper fin from end to end, that is sweated to the tube, and which increases the radiating surface so that extremely efficient radiation can always be obtained. These tubes are fitted with copper plates or slabs that are bolted to the top and bottom tanks of the radiators, and these tanks are also bolted to side members, so that the cooling section is carried in a solid frame that cannot be twisted or distorted. The tanks and side members of the frame may be cast aluminum or other metal, or may be pressed, but when cast radiating fins may be formed which diffuse the heat and at the same time strengthen the parts.

The company will build radiators complete, but it prefers to produce cooling sections only, supplying these to the vehicle manufacturers, who can have the tanks and frame members made to specification elsewhere and assemble the components, for all that is necessary is to place the gaskets between the top and bottom plates and the tanks and tighten the bolts. When the radiators are con-

structed in this manner the manufacturer can have the tanks in design and material to meet his own ideas and can make whatever changes may be desired at any time.

The Rome-Turney Radiator Co. obtains the tube cut to whatever length may be desired. The copper fin is received into the shops in the form of flattened wire that may be likened to ribbon, in large rolls or spools. The tube used is three sizes, $\frac{3}{8}$, $\frac{1}{2}$ and $\frac{3}{4}$ in. diameter, and the walls may be from .028 to .020 thickness. The copper tape from which the helix is formed is either .010 or .012 in. thick and either $\frac{1}{4}$ or $\frac{3}{8}$ in. width. The tube is from 20 to 36 in. length.

In designing a helical tube truck radiator a definite area is determined. If the system is circulated by pumpage the allowance is $8\frac{1}{2}$ sq. ft. of cooling area for each horsepower of normal engine rating for $\frac{3}{8}$ in. tubing, 7 feet if of $\frac{1}{2}$ in. tubing, and $4\frac{1}{2}$ feet if $\frac{3}{4}$ in. tubing. This is worked out very carefully, the $\frac{3}{8}$ tubing having 73 sq. in. of total radiating surface to the running foot of tube, the $\frac{1}{2}$ in. tubing having 89 sq. in., and the $\frac{3}{4}$ in. tube 144 sq. in.

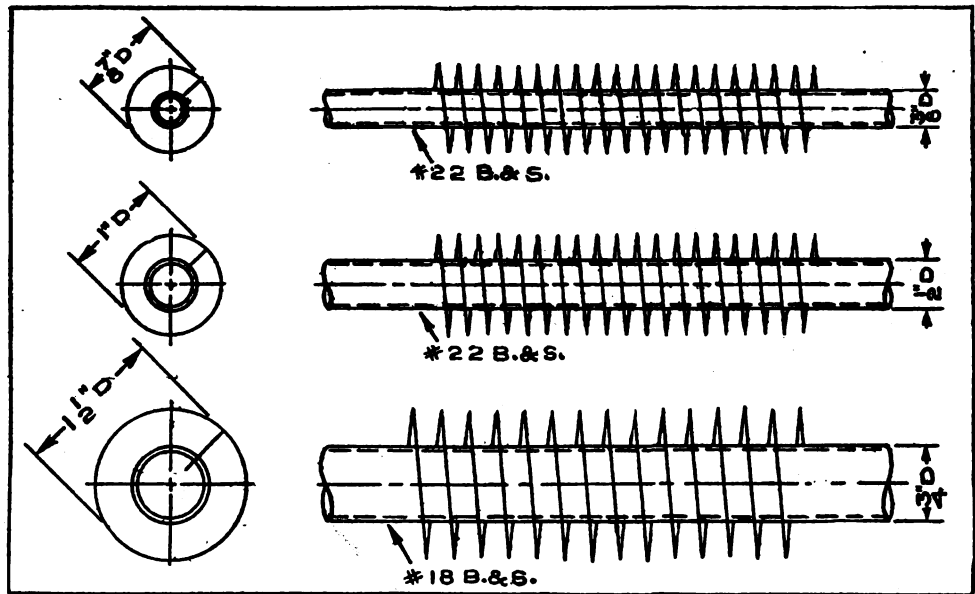

Dimension lines showing the proportions of the tubes and radiating surfaces of Rome-Turney helical tube truck radiators

One will note that there is one square foot of radiating surface to every running foot of the $\frac{3}{4}$ in. tube, and the $\frac{3}{8}$ in. tube has slightly more than a half square foot of radiating surface to the running foot. The proportion of radiating surface to the bare tube is 5.22 for the $\frac{3}{8}$ in. tube, 4.73 for the $\frac{1}{2}$ in. tube, and 5.15 for the $\frac{3}{4}$ in. tube, which shows a very consistent ratio, and the proportion of the radiating surface to the cubic inch of content is 74.5 for the $\frac{3}{8}$ in. tube, 48.2 for the $\frac{1}{2}$ in. and 34.5 for the $\frac{3}{4}$ in. tube.

With these constants the exact radiating surface of an efficient cooling section can be determined, and the length and number of the tubes of different sizes necessary for any engine and for any work accurately found. The statement relative to radiator area applies to forced circulating water systems, and if the engine is cooled by thermosiphon circulation the area is 25 per cent more. The aeroplane radiator, because of the positive and faster circulation of air, is but one-third the area of the truck radiator.

In the shop the tube is received in different lengths. It is seamless drawn and the walls are uniform in thick-

ness. It is inspected to guard against possible defects. The metal for the helix or coil is wound in rolls like ribbon, and to change its shape so that it is practically at an angle of 90 deg. to the tube it is "upset" by machines. Each roll is placed on a plate with its center on a spindle, so that it may be unwound. The loose end is carried through a tool that is known as a "header" and clamped to a collar that is fixed on a mandrel that is turned by power. Each machine has two "headers" and two mandrels that are driven simultaneously. When the machine is operated the copper wire is wound off the plate, through the "header" and on the mandrel, the convolutions being forced in close contact, and the wire then has the appearance of a helical spring. The change is fully shown in the illustrations. This process is exclusively controlled by the company and while the description creates the impression that the process is simple, the construction

helix is firmly held. At the end of the tube the helix is cut and secured. The tube is then taken from the machine with the radiator fin in position as it appears in the radiator.

The soldering process is first dipping the tube in acid baths, and after draining they are dipped into solder heated to approximately 600 deg. F. The tubes are handled with tongs by men who wear cloth gloves and masks to protect them. After dipping they are placed on a run on which they roll rapidly, the centrifugal movement throwing off the molten solder, and then they roll from the run or incline on to a grating which completely clears them of the solder. After cooling the tubes are inspected and the helix straightened if deformed in any way. They are then ready for placing in the top and bottom header plates.

These plates are made preferably of $\frac{1}{8}$ in. copper or brass slabs that are drilled with the required number of holes (as punching would deform them and there would not be the precise fit of the tube that is desired). The tubes are placed in the holes as the cooling sections are assembled, with the ends projecting approximately an $\frac{1}{8}$ in. The plates are given acid baths and coated with solder before assembling. This insures that every joint will be secured. The soldering is done with specially constructed irons and the solder is heaped from the plates to the tops of the tube, forming rings about each that are $\frac{1}{8}$ in. thick, very securely anchoring the tubes and insuring against breakage. The cooling sections are then tested with 10 pounds air under water, and after final inspection are ready for delivery to the customer. When fitted to the tanks rubber gaskets $\frac{1}{16}$ in. thick are placed between the plates of the sections and the tanks, which insures against leakage.

The simplicity of this construction is especially noticeable. In the event of a tube or tubes being damaged these can be removed and replaced by new. The design has been so well proven so far as endurance is concerned that the company guarantees its radiators for the life of the engine, and then another engine. The radiators will endure very hard usage, for if a tube is broken it can be cut and the holes plugged. If there is accident that causes a leak a temporary repair can be made and the machine brought back to the garage. An example of the possibilities is shown in illustrations of a radiator that was in a fire in the plant of the Atterbury Motor Car Co., at Buffalo, N. Y., which was sent to the factory a useless wreck, and of the same radiator after it had been restored.

When these sections are installed in sheet metal cases the cases are strengthened by placing in them wide strips of $\frac{1}{8}$ in. iron that affords the necessary stiffness. How-

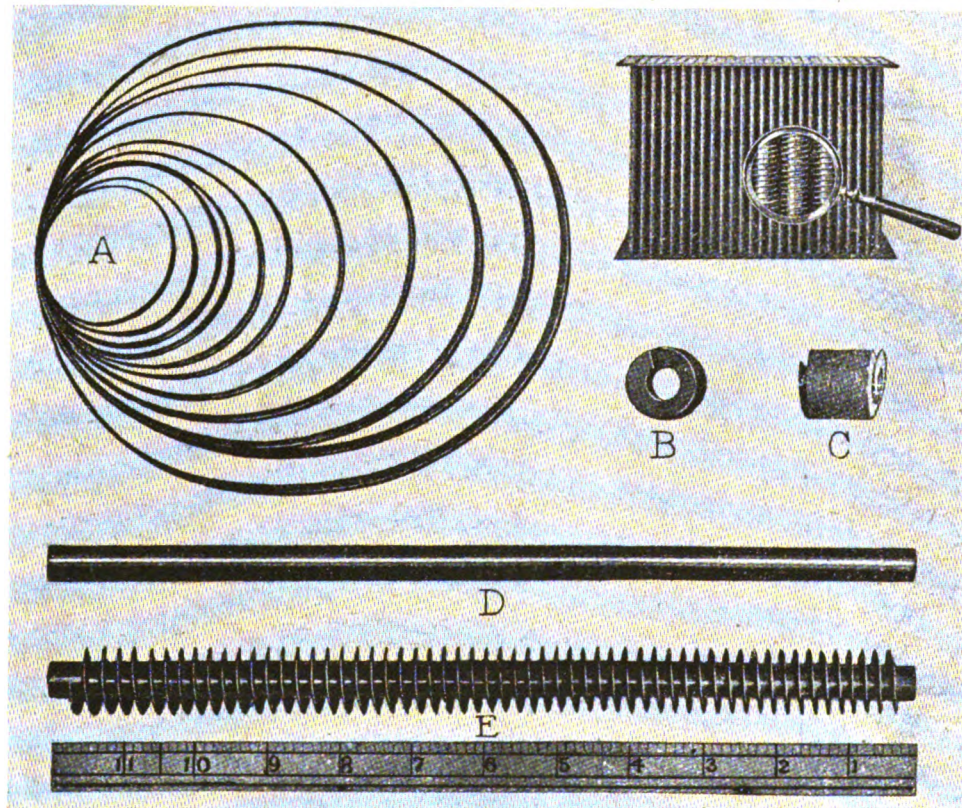

Elements of Rome-Turney helical radiator tube: A, the flat copper wire from which the helix are formed; B, end view of helix after "upsetting"; C, helix as taken from the upsetting machines; D, the bare tube before sweating on the helix; E, the tube complete, the rule showing the number of convolutions to obtain radiating surface

of the machines was a work that required an extremely long period of experimentation before they were satisfactorily operative.

Finishing the Tubes

When the helix are wound the bores are .002 larger than the diameters of the tube on which they are to be used. The tubes are placed in machines resembling lathes, after a section of a helix has been slipped on them. The free end of the helix is shaped with hand cutters and made secure at one end of the tube. A tool is set that as the tube is turned separates the convolutions of the helix so that there are five full turns $\frac{1}{4}$ in. wide to the inch of $\frac{3}{8}$ and $\frac{1}{2}$ in. tube and $3\frac{3}{4}$ turns $\frac{3}{8}$ in. wide to the inch of $\frac{3}{4}$ in. tube. As the helix is stretched along the tube the diameter of the bore is so much decreased that the

ever, the cast frame is approved as being the most desirable, and there is less probability of strains if the radiators are supported by studs from the bottom. The company builds some very large cooling sections, the largest being for use with gas-electric railroad cars that have 1,700 sq. ft. of cooling area.

Annual Convention of C. H. A. T.

The twenty-sixth annual convention of the Carriage, Harness and Accessory Traveling Salesmen's Association was held at the Hotel Sinton in Cincinnati on Monday evening, September 25. The meeting was well attended and full of enthusiasm.

President C. J. Rennekamp called the meeting to order after a few preliminary remarks, and Grant Wright, of Philadelphia, submitted the report of the executive committee, which contained resolutions eulogizing W. W. Wood, formerly president of the organization, who died on July 24. The report also said among others things:

"We believe that the C. H. A. T. has a long and useful life ahead of it, and in this belief we send out the message to all men in the industry that membership in the C. H. A. T. means more than the payment of the small yearly dues; it means that with your membership you should work for the principles of the organization, 'All for one and one for all.'

"Those of us who have read and treasured the reports of the board in the past will hold to the ideals of those reports, but we urge that all face the future with new hope for the success of our calling, and all work through our organization to bring about the best results. This is not an organization for the few, but for the many. We urge members to bring to the attention of our officers ways and means for bettering the organization. We urge members to be mindful of the fact that the C. H. A. T. is planned and operated to help both the salesman and the manufacturer, and that membership in our organization

places every man in the position of using the services of all officers and members to help him in his daily work."

J. A. Niehaus, of the National Hardware Co., was unanimously elected president for the ensuing year. Jesse L. Nelson, Brooklyn, N. Y., was reelected secretary and treasurer for the seventh consecutive term. The other officers are as follows:

Vice-presidents—F. J. Johnson, W. H. Digges, C. A. Quigley, M. S. Bottume, J. Frank Hutcheson, F. S. Collins, W. P. Lippincott, R. A. Bittong, C. G. Ranno, A. M. Williamson, W. F. Terry, A. P. Cleveland, J. C. F. Jackson, D. F. Hass, E. H. Eggers, C. F. Oatway, J. F. Armstrong.

Board of Directors—Grant Wright, chairman; F. D. Reed, P. D. Randall, G. A. Tanner, J. M. Palmer, E. A. McGrew, G. W. Huston, C. J. Rennekamp, W. C. Martin, H. C. Jay, H. S. Cox.

The annual banquet of the association was held in the Gibson House, Wednesday evening, President Rennekamp presiding. About 250 partook of the chicken dinner which was provided, many others being turned away for lack of room.

Among the speakers were: C. S. Clark, president of the Cincinnati Advertisers' Club; Grant Wright, editor of The Eastern Dealer, Philadelphia; Joseph Niehaus, president-elect, and Theodore Luth, president of the C. B. N. A. H. L. Korb gave a clever monologue, after which dancing was indulged in.

Supplying Men as Well as Motors

Not only has the Velie Motor Vehicle Co., of Moline, furnished the U. S. army with large numbers of army trucks, but it is also supplying the men to operate the machines and look after their care. Recently a special train, carrying 25 carloads of two-ton Velie army trucks and two Pullman coaches bearing 54 expert automobile men, left for Douglas, Ariz.

Preliminary Statement on the Manufacture of Automobiles, and Automobile Bodies and Parts

Prepared by the Bureau of the Census, Washington, D. C.

COMPARATIVE SUMMARY: 1909 AND 1914.

	CENSUS				Per cent. of increase 1909-1914
	1914			1909	
	Automobiles	Automobile Bodies and Parts	Total		
Number of establishments	300	971	1,271	743	71.1
Persons engaged in manufacture.....	91,997	53,954	145,951	85,359	71.0
Proprietors and firm members.....	60	700	760	405	87.7
Salaried employes	12,630	5,469	18,099	9,233	96.0
Wage earners (average number).....	79,307	47,785	127,092	75,721	67.8
Primary horsepower	104,983	68,701	173,684	75,550	129.9
Capital	\$312,376,000	\$94,854,000	\$407,230,000	\$173,837,000	134.5
Services	84,901,000	54,552,000	139,453,000	58,173,000	139.7
Salaries	17,966,000	19,560,000	37,526,000	9,479,000	295.9
Wages	66,935,000	34,992,000	101,927,000	48,694,000	109.3
Materials	292,598,000	63,610,000	356,208,000	131,646,000	170.6
Value of products	503,230,000	129,601,000	632,831,000	249,202,000	153.9
Value added by manufacture (value of products less cost of materials)	210,632,000	65,991,000	276,623,000	117,556,000	135.3

¹ In addition, in 1914, 33 establishments primarily engaged in other lines of manufacture, produced automobiles to the value of \$6,636,920, and 434 establishments of this character manufactured automobile bodies and parts to the value of \$10,515,070; in 1909, similar establishments produced automobiles valued at \$830,080 and automobile bodies and parts valued at \$4,415,266.

Engineers Standardize Automobile Names

It has been often said that conflicts between nations, or between groups within nations, are caused by the lack of mutual understanding and appreciation of the various parties involved. The lack of a common and accurately understood language is one of the greatest barriers in international business.

One of the objects of the standardization work now being carried on by the Society of Automobile Engineers is the establishment within the automobile field of a precise and compact language. Copies of a pamphlet on nomenclature were recently mailed to all the members of the society, together with a number of data sheets giving in a concise form the results of standardization work accomplished during the first six months of the present year.

There are many advantages in having uniform names of car parts. The automobile user would find it much easier to make replacements. The manufacturer would benefit for the same reason. The entire industry should welcome any list of names that will remedy the present chaotic condition, in which each maker seemingly uses a different terminology.

The list of names recommended by the S. A. E. was developed through the combined efforts of engineering and service representatives from a number of the leading automobile manufacturers. Over 600 separate names of the more important parts are given but no attempt has been made to list minor parts, the names of which are well settled.

A striking exception to popular usage is the name "engine" which is recommended rather than "motor" to avoid confusion with the electric motors used for starting the engine installed on automobiles. Definitions have been included for axles, brakes and bodies for which usage varies. The names of bodies particularly are in need of standardization because of the wide variety of names used by individual car makers. That this action is appreciated is shown by the fact that the Chicago Automobile Trade Association, composed of practically all the dealers in that city, has recommended that its members adopt the S. A. E. body names. It is likely that the manufacturers, through their organization, the National Automobile Chamber of Commerce, will in the near future adopt the complete nomenclature.

When the difficulties arising from the use of different names for the same things are considered, it surely is desirable that the S. A. E. nomenclature be widely adopted, particularly as it is the result of the painstaking labors of the highest authorities in the industry.

In addition to nomenclature the S. A. E. has adopted a number of other important standards, an outline of which is given on the 39 data sheets sent members of the society. The subjects covered include a new specification for nickel steel, physical properties of nickel and nickel-chromium steels, complete dimensions and tolerances for roller bearings, throttle-lever throw dimensions for carbureters, gearshift positions for three-speed transmissions and dimensions for piston rings of both concentric and eccentric types.

The standards initiated by the electrical equipment division of the S. A. E. standards committee are of special value to every car user. Three sizes of the forked type head-lamp supports are standardized. Dimming devices that operate by reducing the current to the head-lamp are

not recommended for the purpose of eliminating glare. The anchor pins of head-lamp bulbs are to be in a vertical plane when installed. Focusing devices are to be arranged so as to neither revolve nor cause the bulb to move out of its axis; it is recommended that head-lamps be mounted as high as practicable and that the lamp centers should never be less than three feet from the ground. In addition the division has developed complete specifications for the flexible steel tubing used so widely for automobile electric wiring.

Technical School Starts Off With Waiting List

Instructor Andrew F. Johnson, of the Technical School for Automobile Draftsmen and Mechanics, reports that on the opening night of the school, October 2, there were more applicants than could be seated, and since that time applications have been coming in at such a rate that there are now nearly 20 on the waiting list. For several years the school has been overrun, but not to such an extent as this year. This school has proven such a great benefit to those who have taken the course that many are now anxious to have a share in the good things. There is still room in the day class which ought to be filled.

The executive committee of the C. B. N. A. at its meeting last fall concluded to sever its connection with the school, but enough automobile manufacturers have since interested themselves, through the efforts of Daniel T. Wilson, Chas. Richter, and other members of the school board, that it will be kept going without interruption. It will be noted that the name of the institution has been changed to conform to the new order of things. The school is located at the Mechanics' Institute, 20 West 44th street, New York City, and has all the benefits that naturally follow a connection with that institution.

Studebaker to Make Custom Bodies

Owing to the increasing demand for individuality in external appearance, the Studebaker company has made the departure of incorporating within its plant a custom body department in which the range of ideas of purchasers can be met with a corresponding style of body in both open and closed models.

In 1913 the Studebaker company started a body department of its own in which the stock bodies were made, but up to the present time the custom-made bodies have been purchased on the outside.

The method of procedure in securing the specially-built bodies is for the purchaser to describe the type he desires. He is then furnished with a rough sketch prepared by the Studebaker designers and when this is approved it is drawn to full size before the structural drawings are made. In carrying out the work of producing these new bodies, several distinctive shapes have been created, and in each case special style tops have been designed to accommodate the body contour. The custom-made bodies are finished in any color scheme that may be desired.

De Palma Buys Factory

Ralph De Palma and Frank Book, the latter of Detroit, recently organized the De Palma Mfg. Co., to build racing automobiles in the city of Detroit, and have acquired a factory on East Woodbridge street, at a cost of \$23,000. De Palma, who is a veteran racing driver, will supervise the construction of the product.

Steel Conditions--Present and Immediate Future

By Chas. E. Adams*

The old saying is, "That as steel goes, so goes the world," and as steel goes up or down the products of steel and other products go up or down with it. So, since this war began we have seen steel bars that we use very largely go from \$1.25 to \$2.50 to \$2.60 a hundred pounds, and we have seen billets go from \$19 a gross ton to \$46 and \$50 a gross ton; we have seen all kinds of pig iron and all scrap iron, in fact, all kinds of steel products, go up to prices that we never realized were possible, and which we said never could happen. I have bought steel billets as low as \$14 a gross ton, and up to this year I have paid as high as \$32 a gross ton, but, for an average, perhaps from \$22 to \$24 was considered a very high price on billets, and I had supposed that with these modern inventions, with modern labor saving machinery, and with everything being cheapened all along down the line, that we never again were going to see billets at over \$20 or bars at the outside go over \$1.20 a hundred pounds. But something has happened, and billets today are \$46.50 a gross ton, if you can get them at all, and bars are from \$2.60 to \$2.75 a hundred pounds, and we must ask ourselves as business men whether or not these are fictitious values, because when those price go up that high you and I are immediately interested when we realize that there is a drop of from \$25 to \$30 and even \$40 a ton, between the high price that we have to pay today and the low price which we paid, perhaps, a little over a year ago. We also begin to realize that when steel stands a chance to go off \$20 a ton that that is a pretty serious proposition for all of us.

We have on the board of our bank a young man, one of the large manufacturers of Cleveland. He is one of the best read men in Cleveland on our civil war, and on all the wars that have happened. As we sat around this bank board, 24 hours after this war had been declared, we were speculating on what was going to happen to us. Those bankers wanted to know what was going to happen to them, with 25 or 30 million dollars in savings deposits and 120,000 depositors. Our people were perfectly satisfied that this war couldn't last over four months; they said those people would be "busted" in four months; that the war was costing \$25,000,000 a day, and that in four months it would either be ended or the nations would be bankrupt. Our young friend, though, sat at the table and said nothing. Finally, someone said, "Frank, what do you think about the war?" And Frank said, "I think this war will last from three to five years, and maybe ten." Our people were astonished, and they couldn't believe it; they thought Frank was crazy—that he didn't know what he was talking about. But, as it has turned out, he is pretty near right about it, at least up to date. I asked him the other day how long he had it figured out now, and he said, "Why, two or three years more at the outside." We

have men here today who will tell you that this war is going to end by December 1. Gentlemen, there is no hope for this war ending by December 1, unless the Allies want to give up every chance in the world. Perhaps Germany would be perfectly willing to end the war if she could keep what she already has; that may be very true, but as things look now, there is no such chance for an early ending of the war. Now, that's one of the things that has happened to you and I, because, perhaps without knowing it, we are all contributing to this war. Everyone of us who has \$100 or \$200 in the savings bank is contributing. "Oh!" you say, "Our bank doesn't buy any of those war bonds." No, your bank doesn't do it, but your bank deposits your money with some other bank that does do it. Every loan that the Allies have brought over here, whether it was a loan of \$25,000,000 or \$100,000,000 or \$250,000,000 has been taken up, and the last one of those loans has always been taken up easier than the one before. So the sinews of war are being furnished by the 100,000,000 people of the United States, and we will probably be doing that for some time to come.

Steel a Good Buy at Any Price

I believe today that steel and the products of steel and iron are the cheapest at this minute that they will be until 1919. I believe honestly that steel bought today at the present prices, no matter what they are, is a good buy, and I believe that any man who is willing to sell his stuff for six or nine months ahead, no matter if he has every ounce of it covered in his warehouse, is a bad business man, and he is giving away some of the profits that he will need badly at some future time. Every once in a while we hear of some man who thinks a whole lot about his customers and says, "I have this material; I got it right; I was far sighted; I saw ahead, and it is paid for, and I am going to give my customers the benefit of it." Gentlemen, that's bad business. I would like to get some of his stuff myself; I would like to be a customer of his, but I think that's bad business, because I believe we are going to have steadily increasing prices. When you come to the final analysis of all this proposition, after all, most everything that we use, and especially everything in the steel and iron line—the difference between the \$55 or the \$50 billets and ore, is mostly made up in labor. The men up in the northwest who own the land get 25 cents a ton royalty; the ore man may get \$1.50 or \$2 a ton this year, and the rest of it goes to the vessel man or the railroad man and labor. I had a talk yesterday with some of my friends who are here from Georgia, and they told me that labor is still a dollar a day down there. Well, it hasn't reached them yet as it has us, north of the Ohio River, but it is going to reach them, because it is right here, and it is here to stay.

Now, what made labor so high, and why is it that mold-

*President Cleveland Hardware Co. Address at C. B. N. A. convention at Cincinnati, September 27.

ers are scarce, that trip-hammer men are scarce—why is it that machinists are scarce—why is it that all kinds of labor is scarce? To me it is a very simple proposition, when you come to analyze it. Before the war we had a steady flow yearly of 1,000,000 immigrants coming into this country. What did these men come over here to do? They came over here to learn our business. They went into our factories unloading coal and ashes and billets and loading pig iron, and doing the dirty work outside. That's what they did when they came over here. Then, in a little while, somebody wanted a laborer indoors, and he went out into the yard where a man was shoveling ashes on a car, and he said, "John, I want you to labor inside." And John went inside, and he never went back to the ashes again, but he went inside at \$1.75 a day. In a little while after that, one of the men inside wanted a heater, and he went to John and he said, "John, I want a heater on this fire; would you like the job?" And John said "Yes." And John went on the fire at \$2 a day, and when he did, a man outside in the yard came in and took John's place, and still another man just recently through Ellis Island took the place out in the yard. So it kept on all the time, and those men graduated from one job to the other, always moving forward, but never moving backward, until they had graduated into the more expert jobs. But those million men were first doing the things that none of us want to do—the things that none of the men in this country want to do today, and they were first doing those things because they were willing to do anything; they had been trained for that, but when they come over here to America, they only last about six months or a year, and then they are not willing to do those things any more. So we are over 2,000,000 men short, and by the first of August next, we will be 3,000,000 men short, and everywhere business is feeling the loss of those 3,000,000 men who haven't come over.

Common Laborer Will Be Highest Priced Man

I want to make a prediction to you: By the first day of next July, the highest priced men you will have in your places won't be your machinists, they won't be your skilled men, but they will be your common laborers. The common labor is the hardest thing you have to get today, and they will be still harder to get by that time.

So this stuff is bound to cost more all the time, and these steel concerns are getting those prices not only because the stuff is worth it, but for every single ounce that they will be able to produce for 1917 there's a market this minute at prices that are higher than any prices you ever have paid. Every ton of stuff the steel men sell today, no matter what price they get for it, is sold to you at a concession, and when he sells you at all, he is giving you money out of his own pocket. I had a little experience of that kind here less than a month ago. I made up my mind that if we wanted any steel to do business with in 1917, the first part of 1917, we had better get busy and buy it. I had read in the papers, as you no doubt read, that this foreign country was buying 100,000 tons and that one 100,000 tons, and this one 50,000 tons, and that one 200,000 tons. I said to myself, we can't run this plant without billets, and if we are going to do business, this is the time to buy them. I said to our purchasing agent, "I want you to go out and buy 5,000 tons of steel." He asked me, "What price shall I pay?" I said to him, "Any price you have to pay." He went out to get it. Now, ordinarily, if we were in the market for steel, we would

have 15 or 20 men camping at our door to sell it to us. We never had any idea but what we would be able to get some competition on it, but one man after another told us that he had absolutely nothing to sell. Finally, after we had gotten all through, going all around, none of them coming to us, we were going to every one in the business and asking them for that amount of steel, without regard to what the price might be—but finally we found two men. One of those men said, "We started this mill ten years ago, and yours was the first order we had, so as a matter of sentiment, we will let you have 2,000 tons." We bought it. There was another mill in Cleveland that had just started up less than six months before, and they had built that mill with the idea of taking care of Cleveland and vicinity, and they said to us, "When we built, we had your plant in mind, and a lot of other plants in Cleveland, and we still believe that at some time or other we won't have war orders, and we will sell you 3,000 tons or whatever you want." But the seller said, "I want you to know what I am giving you," and he brought out the original order, which showed that they had paid for that steel just \$12 a ton more than they charged us for that 3,000 tons. Now, gentlemen, that is not a fairy tale; that man made us a present of \$36,000. He thought it was good business, because he believed that he would need us some time more than he needs us now. We paid for that 5,000 tons of billets \$130,000 more than we paid for the last we bought, and we were tickled to death that we got it, and we wouldn't sell it today for \$50,000 advance on what we paid them for it.

The Iron Trade Review has said recently that 68 per cent of all steel manufactured in the United States is going abroad in some form or other, and that all those foreign countries are here, ready and willing to take the rest, and my advice to you is, no matter whether you buy steel in the bar, or in some finished form, in hardware or in the malleables, no matter in what sort of shape you buy it, but in whatever shape you buy it, or for whatever it may be worked into, the thing for you to do, if you have the money and can afford to do it, is to buy steel now. Buy as much as you can find; get it in your plant. Pay for it, and then sell as little as you can, because it will make you more money day by day than it will in the finished product, no matter what that finished product may be, and the men who have any idea of going out and selling finished buggies or finished wagons, at prices based on the price of the steel that you bought last year, and perhaps overbought, and you have it in your bins and for that reason you think you can sell your trade a little cheaper—forget it! Because, if we were dealing with anybody like that, we would certainly want to look up their credit—we wouldn't want to sell him, because we would think he would be giving away something that some time he would need and need badly.

Have Seen the Lowest Prices

Some of you may be making some very good profits. Don't spend it all if you are making it, because there's coming a time when you are going to need some of those profits. Don't blow it all in with the idea that prices are going to be lower, for I don't believe anything like that is going to happen this year or next year. I believe that you have seen the lowest prices; in fact, I will guarantee you, and I don't know anything about Mr. Champney's business, only when I have come in competition with him, but I think he believes, and I know I made up my mind,

that you will never see 4½ cent malleables again in this country. I don't believe you will ever buy forgings again as long as you live at the prices you have been getting from the forging manufacturers. I don't believe you will ever see \$1.25 steel bars again, because we are getting up on a different level in this country.

Men are beginning to find out that they can get more money, and they can get it and at the same time do less work for it. And you know what your experience has been; it has been like mine. You have very seldom seen wages go back after they once went up. Perhaps some of these abnormal wages we are paying are not going to last forever, but I am absolutely sure that men generally are getting a taste of something that they never had before; I am absolutely sure that the men of this country, whether foreigners or Americans, are never going to work again as hard as they have worked; that never again are men going to be able to put things over that have been put over. The time is here today when the mechanics, the laboring man, and the man in your factory is demanding a vacation just the same as you have, and he is going to have it whether you like it or not. He has seen you go off fishing or hunting or on some kind of a vacation trip for two or three weeks at a time, and he has asked you for half a day off and you have said, "Oh! no, we are too busy; we would like to have you run your machine every minute; in fact, we would like to have you work overtime." This year he has demonstrated to you that he don't care whether you like it or not, he has gone off for a week, and this winter he will be beginning to plan with his wife what he is going to do for two weeks and they will be laying a little by in the savings bank, and some day he will come out and say to you, "I won't be out Monday; I will be back in a couple of weeks." And you will want to know what's the matter, and he will say, "We are going down home to see the folks in the automobile!" (Laughter.)

Ore Shortage Feared

Now, gentlemen, these are not theories—these are facts, and we have been up against those facts all summer. We have seen the greatest scarcity of stuff; we have seen men who were able to sell their stuff at prices they never dreamed of, and very frequently they can't furnish the stuff even at those prices, because they can't get the one thing they must have, and that is the men. Now, there are a lot of things that make me think that you haven't had much difficulty getting your stuff this last year as compared with the difficulty you will have next year. My friend Jasper Schadell—we just buried him on Monday—but he told me two weeks ago that among the things that were worrying the ore men was this: that they were afraid that there was going to be a shortage of ore next year. He said that for several years the ore men had not sent down as much ore as they had produced—that they had produced a great deal more ore than they had brought down, but that they had kept the men working and piled the ore up in stock piles outside the mines, but this year they were bringing down every ounce of those stock piles and that there wouldn't be a stock pile of ore left in the northwest—not one—every ounce of that surplus ore was coming down. He said that there was only one hope, if they could find enough soft ore, that they could scoop up with steam shovels, they might be able to keep up with the demand, but even then, there may not be ore enough.

All these are things, I think, that we ought to think

about. I think this steel business is the most serious thing we are facing today. I think it is the thing we are most interested in. If there is any question in your mind as to whether you ought to buy, just remember this, that the question is whether you want to sell. Of course, you have got to sell—you have got to keep on doing business, and to do that, you have got to buy, but if you have any notion in your mind today that you are going to get your steel for less tomorrow, or that you are going to get your material more promptly—if you have any notion of that kind in your mind, you want to get it out of it from today, because the other people are here, and they are actually buying it and paying the price for it, and they are ready and willing to take it.

Did you read in last night's paper that a man from Japan went to Pittsburgh last Saturday and bought \$5,000,000 worth of steel products in Pittsburgh for Japan? Do you know that they are buying it for China? The steel orders we are talking about are not all for Germany, for France, England or Russia—they are all coming to America. Do you realize that when we sit here and talk of this war coming to a close that the men down east, the men who are closest to those warring nations, are spending today millions and millions of dollars for buildings and machinery and land? What for? To make war munitions for those foreign countries in 1917, 1918 and 1919, and they haven't got all those plants built yet. They are not selling the machinery they had; they are buying more, and they are getting more order than they ever got before. So when we sit here and talk about the end of the war, we can only hope for it, and God knows, everyone of us hopes for it, as a possibility. But, it may be said, why don't they make their own steel?

Belgium and France Steel Plants Gone Forever

The first thing Germany did was to go and take Belgium and those parts of France where they had the finest steel works in the world, and they tell me what they did with those plants was to take what stuff they needed in them and ship it to Germany, and then burn the rest down, and those plants will never be replaced. If the war were over today, if Belgium were put back where she was before the war, her steel mills are gone, and those that were in France are gone, and they will never be replaced. Germany took what she could to Germany and blew up and burned up the rest, as she naturally would do.

My prediction is that before the first of January that bar steel will be easily \$2.75 base, and that not later than the first of April it will be at least three cents base, if not more. It is not a question of what prices we pay for this stuff, because there are people who want it, and apparently worse than we do, and they are willing to pay the price. It is simply a question of supplying the demand, and at the present time the supply is not equal to the demand.

Now, I hope I haven't tired you with this tale of mine. You may think I am an optimist; I am. I believe we are going to have a good business this year; I believe we are going to have a harder time in getting out the stuff this year than we ever had in all our lives. I don't believe that in our business it is going to be a question of selling, but I do believe that the question will be whether or not we can get it to make the stuff that we can sell, and the best stuff that you have got, the most profitable stuff you have got in your entire plant is not the steel you have got bought or ordered, but the steel you have got in your bins.

Permanently Enclosed Springs

The accompanying drawings show a spring system designed by Lt. J. M. Sanders, Bristol, Eng. The object of the designer has been to provide a permanent protection and oil bath for the springs, and to attain this end he has enclosed a cantilever spring, as shown, in a taper tubular torque and radius member on each side of the chassis. At the rear end each spring rests upon a special seating for it secured inside the end of the casing, and the casing itself is intended to be secured to the back axle while the spring moves within it.

At the front end both the casing and the spring are supported by two helical springs, the longest leaf of the

assembling the parts the spring is inserted through the open front of the casing, and the pivot bolt is then pushed through the side of the casing and the spring bearing. The cantilever type spring is mounted at the center on an eccentric pivot bearing in order that, when the body is fitted upon the chassis, the spring may be set to raise or lower the frame of the chassis so as to render the whole structure normally horizontal.

"Knights of the Motor World"

Twenty representative men, well known in the automobile industry, on Friday evening, August 11, at the Vendig Hotel, Philadelphia, formed a permanent national organization which will be known throughout the country as the "Knights of the Motor World."

Those present included men from the sales departments and executive offices of various automobile concerns, also representatives of auto tires and auto concerns in Philadelphia and other cities.

The new organization is confined to the automobile industry, and although the formation was begun in Philadelphia, it will soon be carried to other cities, until it becomes national in its scope.

The Knights of the Motor World will be beneficial, fraternal, as well as a social organization to bring closer together the men of the automobile industry.

Members will have their choice of becoming beneficial and social members, or social alone. The beneficial member will receive sick, accident and death benefits in one of the largest insurance companies of the United States.

The insignia of the organization will be in the form of a button, worn on the lapel of the coat, being a gold automobile wheel, with a knight in the center, the tire of the wheel being blue, with the words: "Knights of the Motor World."

Robert I. Erlichman, of the Berrodin Rubber Co., is commander of the new organization.

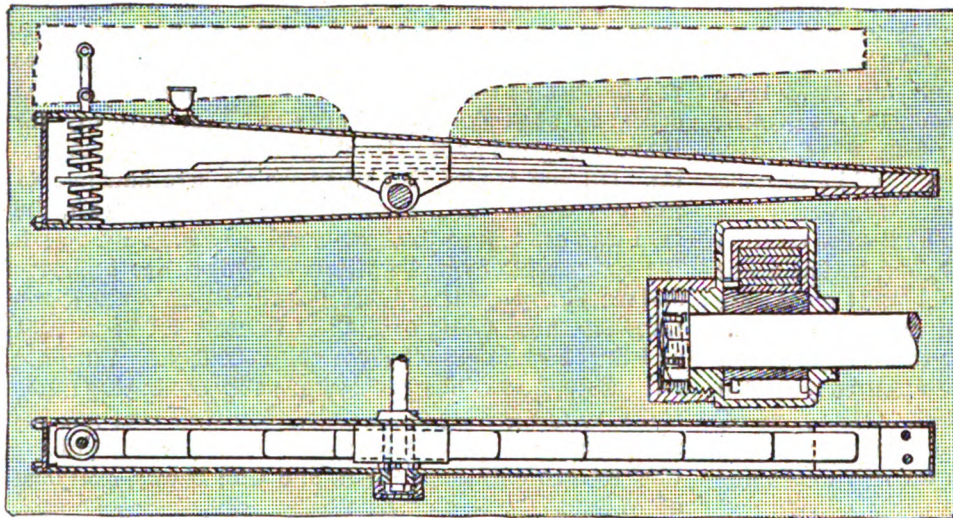

The Sanders spring system as applied to cantilever springs, with enlarged view of the trunnion bearing

cantilever spring being supported between the two supplementary springs as shown, while the casing itself makes use of the same helical springs for its abutment above and below. Both cantilever spring and casing are pivoted on the same center, as shown in the cross-sectional view, so that there is no relative movement between them at this point, although this is not an essential feature.

In the case of a grasshopper spring the casing and the spring, as shown in the illustration, are pivoted in a similar way to that adopted in the case of the cantilever spring on one and the same center, and the rear end of the spring

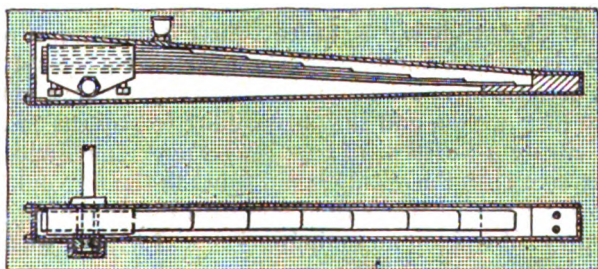

The Sanders system of grasshopper spring suspension

rests upon the seating provided for it within the casing.

In both arrangements the spring casing is closed at the front end and rendered oil-tight, and by means of the oil filler provided (shown in two of the views) the casing can be kept full of oil, so that the spring leaves themselves work constantly in an oil bath, and the pivot bearing of the spring and casing are kept thoroughly lubricated. In

Klaxon in United Motors

The Lovell-McConnel Mfg. Co., of Newark, N. J., manufacturer of the Klaxon horn, has been purchased by the United Motors Corporation and will be made one of the subsidiaries of the latter concern, together with the five other companies already merged, the Perlman Rim Corporation, Remy Electric Co., New Departure Mfg. Co., Hyatt Roller Bearing Co., and the Dayton Engineering Laboratories Co.

The name of the latest acquisition has been changed to Klaxon Company and the concern's productive capacity will be immediately doubled to care for the enormously increased business which has been recently acquired. One of the concern's largest contracts is with the Willys-Overland Co., to run for a term of years, and term contracts have also been made for the exclusive use of this horn on all cars manufactured by the Buick, Cadillac, Oldsmobile, Oakland, Scripps-Booth and Chevrolet companies.

Submarine Model on Mitchell Chassis

An unusual amount of ingenuity has been exercised in designing a special submarine body which has made its appearance recently on the streets of New York. The body was planned by J. H. Clark, of the Mitchell sales force in New York, and several bodies of this type mounted on Mitchell mid-season model chassis have found a ready sale among the younger New York set.

The body, wire wheels, radiator and hood are finished in white enamel and the fenders and running gear are finished to match the upholstery. The body is described as ultra-aquatic, the smooth sides coming to a point at the rear and a planked deck of matched mahogany adds to the nautical appearance.

The carrying capacity is six people, the single door being located on the starboard side. The right front cushion tilts up and affords ready access to the tonneau. The top is of special design similar to the yacht deck top, carries out the yacht effect and is effectually concealed when not in use.

Standard Welding Promotions

Following the resignation of H. A. Flagg, sales manager of the Standard Welding Co., and C. E. Miller from the management of the Detroit office, P. W. Gilbert, assistant sales manager, becomes sales manager; B. A. Quayle, in charge of the Chicago office, becomes general representative, with headquarters at the factory. B. G. L. Dodge, in charge of advertising and publicity, becomes manager of sales promotion.

W. C. Voss, formerly in charge of the Cleveland district, moves to Detroit, where he will assume charge jointly with Ted Palmer. Willus Stutson, of the Indianapolis district, is placed in charge of the Chicago office, with A. J. Brandt as assistant. Mr. Stutson will also handle the Indianapolis district from Chicago. O. L. Miller, formerly of the order department of the factory, replaces Mr. Voss at Cleveland. T. E. Hauser, formerly head of the order department, becomes assistant to the sales manager, while W. Paxton becomes head of the order department.

Buggy Company to Quit

According to reports, the Connersville (Ind.) Buggy Co. at a recent meeting of the board of directors voted to wind up the company's affairs. There is no hint of financial difficulties, but the management, according to the statement, feels that more can be realized by discontinuing the business now than by endeavoring to maintain the vehicle business at a volume in keeping with the capacity of the factory. The company was established about a quarter of a century ago and conducted a profitable business until the automobile made such inroads into vehicle sales.

Brantford Buys Baynes Carriage Co.

The Brantford Carriage Co., Ltd., recently purchased the business of the Baynes Carriage Co., Ltd., of Hamilton, Ont.

Will Manufacture Fifth Wheels

Camp Brothers & Co., of Washington, Ill., have bought the manufacturing rights of a patented fifth wheel for

wagons from Joseph Villiger, a Metamora blacksmith, and will manufacture the invention at their factory. Mr. Villiger invented the fifth wheel several years ago. It is composed of two cast iron discs, operating on ball bearings. The bolster of the wagon is fastened solidly to the upper disc and the whole is made so firm there is no tilt to the front of the wagon bed.

Budd Wheel Co. to Enlarge

The Budd Wheel Corporation, of Philadelphia, Pa., recently incorporated for \$2,000,000, to manufacture steel and wire wheels of its own design, will occupy part of the new building being erected at Twenty-fifth street and Hunting Park avenue by the Budd Manufacturing Co., maker of all-steel bodies. The new company will have about three acres of floor space in the new building. W. B. Read is secretary and treasurer of both companies.

Ford to Build Plant in England

The Ford Motor Co., of Detroit, states that the Ford Motor Co., of England, a separate corporation, will shortly erect a large plant near Southampton, England, for the production of Ford cars. Construction will be in charge of L. D. Perry, who sailed for England on October 6. The general details of the new factory will be planned by Mr. Perry after his arrival.

Overland Buys Newark Service Plant

In the bringing to completion of its plans for taking direct charge of the Metropolitan territory through the medium of a factory branch, the Willys-Overland Co., Toledo, O., has bought the one-story building at 243 Central avenue, Newark, N. J. This had been erected by the C. T. Silver Motor Co. as a service station, and will now be operated as such by the Overland company itself.

To Specialize on Hearses

The Houghton Motor Co., Marion, O., announces its production scheduled for the coming year as 500 ambulances and hearses. Fifty of the vehicles are to be delivered by January 1, 1917. All vehicles are to be delivered by October 1, 1917. The concern has been devoting the past year to experimental work.

Sells One Hundred Buggies

Robert Orr, Brooklyn, Ia., dealer, reports a great year for the buggy trade. He says he already has sold 100 buggies this season and that with 10 good prospects in view he confidently expects to sell at least that many more before winter rings down the curtain on the light vehicle trade for the year.

All-Weather Top for Chevrolet

The Chevrolet Motor Co. is supplying as standard equipment an all-weather top which is removable. This top, which is made by the Detroit Weather Proof Body Co., will cost \$70 extra.

Fire that swept rapidly through structure destroyed the building and stock of the Schurmeier Wagon Co., Ninth and Pine streets, St. Paul, Minn., September 23, causing a loss of \$20,000.

Records Fix Individual Wage Rates

Facts which are systematically recorded at regular intervals and tell precisely the quantity and value of services performed by a workman, now fix individual wage rates at the Franklin automobile plant in Syracuse, N. Y.

This system, developed by the Franklin company, represents the first attempt in this country to measure the value of factory workers with mathematical certainty and consequent equity for both employer and employes.

The method has proven a success so far and is gradually being applied to all of the 2,000 workmen at the plant, who can properly be rated. At present about 400 men are under the system.

Proficiency, reliability, continuity of service, indirect charges, the cost of living and periods of lay-off are factors which determine, for example, whether John Doe, operating a lathe, shall receive 35 cents or 45 cents an hour as a base rate.

First, an employe's record is investigated, and from this information are determined the factors of an algebraic equation, which is then solved.

The solution is the day rate per hour, upon which the worker has an opportunity to earn a steady premium. The higher the premium he earns, the higher the base rate rises. Fixing premiums is a complex problem due to the conditions imposed. But here are the essential elements:

Rate of production.

Spoiled work or damage to equipment.

Years of continuous service.

Lateness and absence.

Number of major processes which the worker can do.

Monetary responsibility which is placed in the hands of the worker.

With a base rate fixed, it is up to the employe to make a record on his rating reports which will fatten his pay envelope. Several months experience has shown an eagerness on the part of the employes to take advantage of the new opportunity, and as a result there has been a general increase in the wages of the persons rated.

Decline in Buggy Sales

At the annual meeting of the stockholders of the Moline (Ill.) Plow Co., President Stephens pointed out that the sales for the year show an increase of approximately 5½ per cent over those of the preceding year, the improvement having been made in the foreign business of the company. Sales of all products have been maintained excepting Henney buggies, the decline of this product being attributed to the prevailing conditions in the southern states and the tendency of the times to substitute automobiles for horse-drawn vehicles. The company has recognized the latter tendency and has made provision to meet it by converting one of its buggy factories in Freeport for the production of automobiles.

The Torbensen Axle Co.

The Torbensen Axle Co., which was formerly called the Torbensen Gear and Axle Co., will shortly occupy its new plant in East 152d street, Cleveland, O., which is rapidly nearing completion. The manufacturing shops, as well as the offices of the company, will be located at this site.

The new works, which are located on a property of four acres, will be a model of up-to-date construction and will

be equipped with the very latest types of modern machinery, enabling the company to considerably increase its production.

Four buildings are now nearing completion, a machine shop with 12,000 square feet of floor space; a machine shop with 10,000 square feet of floor space; a warehouse with 4,000 square feet of floor space, and a warehouse with 10,000 square feet of floor space. In the near future another machine shop with 15,000 square feet of floor space will be added.

Electric Car That Will Recharge Itself

The building of an electric car with a battery that will recharge itself when running on level ground, and which can run two or three days without getting a boost, is being planned in Boston. The car will run very cheaply, will weigh less than 1,500 lbs. and will sell in the neighborhood of \$500. Plans are under way to place the stock on the market, and the men behind it are all big enough so that their names mean something. The man who has devised the machine has a national reputation in the electrical world, and is connected with the biggest company in the country making electrical apparatus.

An experimental car has been thoroughly tried out and it has proved a success.

Kentucky Wagon Promotes Executives

W. I. Shaw, who has been sales manager of the Kentucky Wagon Mfg. Co. and the Dixie Motor Car Co., Louisville, Ky., has been made general sales manager of these companies. Stephen K. Miller, who has been assistant sales manager, is promoted to sales manager of the wagon department. Frank H. Holman has been appointed sales manager of the gasoline truck department, and A. B. Challinor will become sales manager of the passenger car department. These promotions and additions have been made necessary by the increase in the company's business. The number of employes is one and a half times the number a year ago.

Columbia Motors Buys Argo Electric Co.

The Argo Electric Vehicle Co., Saginaw, Mich., has been purchased by the Columbia Motors Co., Detroit. The Columbia Motors plans to begin the manufacture of its new car January 1, 1917. This company is capitalized for \$500,000 and expects to produce approximately 3,500 cars during the coming year at a price of about \$1,000. The first Columbia was produced early this summer, but further product was delayed pending the Argo purchase.

The new merger admits the Columbia Motors to a membership in the National Automobile Chamber of Commerce, and allows them to exhibit their product in the national automobile shows in New York and Chicago this next winter.

Removes Department to Toledo

The Doehler Die-Casting Co. announces the removal of its brass-back bearing department from the Brooklyn to its Toledo plant, where an entire new factory building, housing foundry and machine shop, fully equipped with all modern labor-saving devices, is devoted to the exclusive manufacture of "Doehler" babbitt-lined brass-back bearings.

Use of Rubber Tires in Guatemala

The director of police of Guatemala City states that of the rubber tired vehicles in use in that capital 307 are carriages of all sorts, 113 are automobiles, 573 bicycles, and 17 motorcycles, a total of 1,010. It is safe to say that in the rest of the country there are not more than 15 or 20 automobiles and rubber tired carriages.

As there is no specific provision in the Guatemalan customs tariff for rubber tires, the director general of customs for the republic was asked for a ruling. He replied that automobiles, tires, and other accessories are classed with carriages and their accessories, the duties on which are as follows:

Paragraph 1367—Carriages weighing up to 100 kilos, per kilo (2.2046 pounds) net weight, 0.30 peso (\$7.21 per 100 pounds).

Paragraph 1368—Carriages weighing from 100 to 250 kilos, per kilo net weight, 0.28 peso (\$6.73 per 100 pounds).

Paragraph 1369—Carriages weighing from 250 to 500 kilos, per kilo net weight, 0.25 peso (\$6.01 per 100 pounds).

Paragraph 1370—Carriages weighing from 500 to 750 kilos, per kilo net weight, 0.22 peso (\$5.29 per 100 pounds).

Paragraph 1371—Carriages weighing from 750 to 1,000 kilos, per kilo net weight, 0.20 peso (\$4.81 per 100 pounds).

Paragraph 1372—Carriages weighing more than 1,000 kilos, per kilo net weight, 0.17 peso (\$4.09 per 100 pounds).

He indicated that automobile tires and rubber tires for carriages when shipped alone would be classified under paragraph 1367, but it is believed that tires shipped with a carriage or automobile would be subject to the same duty as the vehicle to which they appertain.

Duties are payable one-half in United States currency and one-half in the money of the country, which is worth about \$0.023 gold to the peso.

Tri-State Exhibit Called Off

Directors of the Tri-State Vehicle and Implement Dealers' Association have decided to cancel the annual exhibition of implements and vehicles announced to take place at Louisville, in November. In connection with this announcement it is stated that the association's annual exhibit has not yet been abandoned, but will be renewed one year hence.

The Tri-State association will hold a meeting at Louisville, December 1, at which time the question of organizing separate state associations for Kentucky and Indiana will be discussed. Ohio, the third state embraced by the Tri-State association, has a separate organization, which was formed at a meeting held in Columbus last winter. The present officers of the Tri-State association will submit the question to members from Kentucky and Indiana and will support whatever plan the members agree upon.

Perfex Radiator Erects New Plant

The Perfex Radiator Co., Racine, Wis., manufacturer of pleasure and commercial car and tractor radiators and cooling systems in the middle west, on October 9, began operations in its new factory at Holmes and Fleet avenues. The factory is 75 x 255 ft. in size, and a model of factory lighting and sanitation. The capacity is increased to 400 radiators a day by the improvement. More than 150 skilled men are employed at this time. The new plant represents an investment of \$45,000 to \$50,000.

Enormous Truck Exports

During the fiscal year ending June 30, 1916, a total of 21,265 commercial vehicles, valued at \$56,805,548, were exported from the United States as compared with 13,996 during the corresponding period in 1915, of a value of \$39,140,682. During the fiscal year ending June 30, 1914, the exports of commercial vehicles totaled only 784, with a valuation of \$1,181,611.

In July of this year there was marked falling off in the exports of trucks, only 1,243 being shipped as against 2,469 during July, 1915.

151,067 Overlands in Year

The Willys-Overland Co., Toledo, O., shipped 151,067 automobiles during the 12 months ending September 19, of which 59,378 were small light cars. This is nearly double the record of the preceding 12 months when 80,750 cars were shipped. More unfilled orders for immediate shipment are on hand at present than there were a year ago.

Death of Former Tri-State Secretary

R. M. Brown, Shelbyville, Ky., who was secretary of the Tri-State Vehicle and Implement Dealers' Association during the early days of its career, died during the past month at Henderson, N. C. He was 49 years old and is survived by a son, Verlong, who makes his home in Chicago.

Silver Will Handle Dort in New York

C. T. Silver has closed a contract with the Dort Motor Car Co., Flint, Mich., to sell the Dort car in the New York territory.

STATEMENT OF THE OWNERSHIP, MANAGEMENT, ETC., REQUIRED BY THE ACT OF CONGRESS OF AUGUST 24, 1912, OF THE HUB, published monthly at New York, N. Y., for October 1, 1916.

State of New York,

County of New York, ss.

Before me, a Notary Public in and for the state and county aforesaid, personally appeared G. A. Tanner, who, having been duly sworn according to law, deposes and says that he is the Business Manager of The Hub, and that the following is, to the best of his knowledge and belief, a true statement of the ownership, management, etc., of the aforesaid publication for the date shown in the above caption, required by the Act of August 24, 1912, embodied in section 443, Postal Laws and Regulations, to wit:

1. That the names and addresses of the publisher, editor, managing editor, and business manager are:
 Publisher, Trade News Publishing Co., 25 Elm St., New York, N. Y.
 Editor, G. A. Tanner, 25 Elm St., New York, N. Y.
 Managing Editor, none.

2. That the owners are: (Give names and addresses of individual owners, or, if a corporation, give its name and the names and addresses of stockholders owning or holding 1 per cent or more of the total amount of stock.)
 G. A. Tanner, 25 Elm St., New York, N. Y.
 Joseph H. Wright, Tom's River, N. J.
 G. A. Tanner, 25 Elm St., New York, N. Y.
 Geo. W. Hills, Fairfield, Conn.

3. That the known bondholders, mortgagees, and other security holders owning or holding 1 per cent or more of total amount of bonds, mortgages, or other securities are: None.

4. That the two paragraphs next above, giving the names of the owners, stockholders, and security holders, if any, contain not only the list of stockholders and security holders as they appear upon the books of the company but also, in cases where the stockholder or security holder appears upon the books of the company as trustee or in any other fiduciary relation, the name of the person or corporation for whom such trustee is acting, is given; also that the said two paragraphs contain statements embracing affiant's full knowledge and belief as to the circumstances and conditions under which stockholders and security holders who do not appear upon the books of the company as trustees, hold stock and securities in a capacity other than that of a bona fide owner; and this affiant has no reason to believe that any other person, association, or corporation has any interest direct or indirect in the said stock, bonds, or other securities than as so stated by him.

G. A. TANNER, Business Manager.

Sworn to and subscribed before me this 4th day of October, 1916.

(SEAL)

JOSEPH R. FRITH,

Notary Public, New York County.
 (My commission expires March 30, 1918.)

Trade News From Near and Far

General News of the Vehicle Trade

The Ford Motor Co. of Canada, Ltd., Ford City, Ont., has commenced the erection of an assembling plant at Calgary, Alberta.

The National Screw & Tack Co., Cleveland, has acquired a site, 45 x 143 ft., adjoining its present plant, on which to build additions.

C. Cowles & Co., manufacturers of carriage hardware, New Haven, Conn., have awarded a contract for an addition, 61 x 160 ft., five stories.

The Fehring Carriage Co., Columbus, Ind., has begun construction on two additions to its plant, one to be 27 x 100 ft., and the other 50 x 50 ft.

The Maxwell Motor Car Co. will commence work shortly on the erection of a plant at Windsor, Ont., to cost \$50,000. A site was purchased some time ago.

The Dayton Steel Wheel Co., Dayton, O., has been incorporated with \$50,000 capital stock by George Walther and others. Manufacturing plans have not yet been given out.

The Chevrolet Motor Co. of Texas has been incorporated at Fort Worth for the purpose of constructing an automobile assembling plant in that city, to cost about \$600,000.

The Winton Co., Cleveland, is having plans prepared for an addition to its automobile plant to cost \$80,000. Contracts will be placed so that the work can be started early in the spring.

The Fostoria Light Car Co. has filed a voluntary petition in bankruptcy. Liabilities are given as \$223,387.42 and assets, consisting of real estate, machinery and materials, at \$398,768.44.

The Haynes Automobile Co., Kokomo, Ind., will build an extension to its present office building 100 x 116 ft. Two lots were purchased to make the extension possible. Work will be started at once.

The Perlman Rim Co., Jackson, Mich., is working on an addition to its factory, 100 x 440 ft. A similar unit has just been completed; also an addition, 80 x 380 ft. These were made necessary by increased business.

The Chevrolet Motor Co., Flint, Mich., has acquired property on Monmouth street, Hightstown, N. J., and will build a plant for assembling work for all cars sold throughout this section, including Trenton and vicinity.

The Chandler Motor Car Co., Cleveland, will enlarge its plant by the erection of a four-story reinforced concrete building, 60 x 500 ft., to be used for assembling and finishing. Ernest McGeorge, Cleveland, is the architect and engineer.

The Peerless Motor Car Co., Cleveland, has placed contracts for two three-story factory buildings, one 60 x 270 ft. and the other 53 x 160 ft. It has completed plans for a one-story steel-frame building with saw-tooth roof, 120 x 300 ft., all to be used in the manufacture of touring cars.

The Star Motor Car Co., Cincinnati, has been incorporated with \$200,000 capital stock and will establish a plant for assembling steam-driven automobiles. Among the equipment wanted is one 16 in. lathe, several upright drilling machines and portable electric drilling machines. R. M. Wallingford, 1903 Race street, is secretary.

The Victor Motor Co., 1530 Chestnut street, Philadelphia, has taken over the business of the Victor Car Co. of Philadelphia, automobile maker. Twelve acres of land have been purchased at Grubbs Landing, Del., five miles north of Wilmington on the Pennsylvania Railroad, of which five acres are to be utilized by the Victor Motor Co. for a plant and the other seven acres are to be developed for housing employes. The factory will be put up in units, the first being 80 x 425 ft., with a separate power house. It is planned to have the structure complete by December 1. It will be one story, of steel frame construction.

Doings of the Motor Truck Builders

The Gramm-Bernstein Motor Truck Co., Lima, O., will build large extensions to its plant.

The Knutsen Motor Truck Co. has been incorporated at Cleveland with a capital of \$50,000.

The Indiana Truck Co., Marion, Ind., has increased its capital stock from \$200,000 to \$250,000.

The Atterbury Motor Car Co., Buffalo, is repairing fire damage to its plant, Elmwood and Hertel avenues, at a cost of \$20,000.

The Cadillac (Mich.) Auto Truck Co. will shortly bring out a new model. This will be a 3½ ton truck, the largest yet made by this concern.

Incorporation papers have been issued to the E. V. Stratton Motors Co., Albany, to manufacture motors, trucks, etc. The capital stock is \$51,000.

The merging of the Signal Motor Truck Co. and the Commerce Motor Truck Co. at Detroit, under the name of Signal-Commerce Motor Truck Co. has been abandoned.

The United States Motor Truck Co., Covington, Ky., reports the receipt of an order for 25 large trucks to be shipped to Norway. It has recently filled orders from both England and France.

The Rainier Motor Corporation has been chartered in New York state with a capital of \$600,000 to manufacture the Rainier truck. The incorporators are J. T. Ranier, P. N. Lineberger, and J. A. Rainier.

The Commercial Automobile Co., Lexington, Ky., will equip a plant for assembling automobile running gears and bodies and for the manufacture of bodies, etc. Equipment to cost \$8,000 will be installed.

The American Motor Truck Co. has announced its 1917 model, a two-tonner, equipped with a 36 h.p. Wisconsin motor. The company's executive offices are in New York City and the factory is in Hartford, Conn.

The St. Louis Motor Truck Co., St. Louis, Mo., has been bought by H. A. Woerman under the name of the Anchor Auto Co. He will continue the manufacture of the Paulding trucks and give service to present owners.

The Myers Machine Co., Sheboygan, Wis., is now making regular deliveries of the Wisconsin motor truck. The company was reorganized several months ago to purchase the Wisconsin Motor Truck Co., Baraboo, Wis.

E. H. Orersmith, Jonesville, Mich., who is building motor trucks of the front-drive type on a small scale, is negotiating with the business men's association of Waukesha, Wis., with a view to establishing a plant at that point.

The Gramm-Bernstein Co., Lima, O., has been reorganized, its capital stock increased to \$4,000,000, and named the Gramm-Bernstein Motor Truck Co. M. Bernstein is president and treasurer; B. A. Gramm, vice-president and general manager.

Organization of a holding company in New York to be known as the United Truck and Equipment Co., to operate the United Motor Truck Co., is being perfected. Other companies may be controlled by the holding company, possibly including the Republic Truck Co., Alma, Mich.

The Hurlburt Motor Truck Co., Third avenue and Harlem River, New York, has plans for turning out a new one-ton motor truck, beginning January 1. Certain driving parts will be manufactured, otherwise the truck will be an assembled machine. It is expected to turn out 5,000 a year.

The Essex Motor Truck Co., of New York, is planning a new factory building to be erected at Flushing, L. I. The structure will be one story in height with a saw-toothed roof. The main offices of the company are being moved from 299 Madison avenue in New York City, to 1649 Broadway.

The Abbott-Downing Co., of Concord, N. H., will open sales rooms on Brookline avenue, in Boston, for the distribution of truck bodies. This concern is one of the oldest carriage manufacturing firms in the United States and for some time has been contemplating the manufacture of complete motor trucks.

The Moreland Motor Truck Co., Los Angeles, Cal., has announced a new model light delivery truck, the chassis to sell at \$990. This is a 1,500 pound capacity rapid service utility truck, equipped with Wisconsin motor, Timken axles and roller bearings, three-speed transmissions and with solid or pneumatic tires optional.

The Gary Motor Truck Co., Gary, Ind., which is now manufacturing $\frac{3}{4}$ -ton, 1-ton, $1\frac{1}{2}$ -ton and 2-ton trucks, will soon build a $3\frac{1}{2}$ -ton worm drive machine. The engineering department of the company is now working on the design, which will be known as the model K. It will be equipped with Buda motor and Sheldon axles.

The Commerce Motor Car Co., Detroit, has increased its capital stock from \$200,000 to \$400,000. The company is bringing out a new one-ton truck, of which 3,000 are to be built during the fiscal year. The price is \$1,175 for the chassis with seat. There will also be made 1,800 $\frac{3}{4}$ -ton trucks. An addition 250 x 60 ft. is being added to the plant.

The Willys-Overland Co. has put on the market the new Overland 75-B chassis fitted with a panel delivery body, selling at \$625 f. o. b. Toledo. Features are the

four-cylinder $31\frac{1}{2}$ h.p. block engine, electric starting and lighting system and 31 x 4 in. tires. The panel delivery body fitted provides more than 78 cu. ft. of loading space back of the car. The driver's seat extends only half way across the car. The car is light and has a short turning radius.

Body Builders Briefs

The Springfield Body Co., of Springfield, Mass., has purchased a factory site near Dearborn, Mich. They will employ between 4,000 and 5,000 men.

The Edward G. Budd Mfg. Co., 25th street and Hunting Park avenue, Philadelphia, manufacturer of steel automobile bodies, etc., has awarded contract for electrical equipment for its recent plant additions, at an estimated cost of \$20,000.

The Harvey Top & Body Co., Buffalo, has been incorporated with a capital stock of \$20,000 and will establish a plant for the manufacture of autos, auto tops, bodies, etc. Lambert G. Smith, Farnham, N. Y.; Henry C. Harvey and Harvey B. Harrison, 614 Morgan Building, Buffalo, are the incorporators.

The J. S. Morris Co., Waupun, Wis., carriages and vehicles, is now specializing in the manufacture of special motor car bodies, such as hearses, limousines, coupes and other types. Several hearse bodies were delivered recently and orders for similar bodies are on the books and will require maximum production for five to six months to fill.

The Hench & Drongold Co., York, Pa., large manufacturer of garden implements, has entered the automobile field as maker of wood work of all kinds for automobiles and trucks, including bodies and parts of both wood and metal. The company will also build special machinery and do machine and forge work. Special equipment has been installed in the company's large new plant, which covers about six acres.

Herbert E. Barkley, manufacturer of auto bodies for delivery trucks, at Grand Rapids, Mich., will erect a two or three-story steel and brick building to provide facilities for doubling the output of his plant. Mr. Barkley is a pioneer in the wagon and automobile business and, in addition to his auto body business, has a large repairing and refinishing department. Several months since his plant was badly damaged by fire, and since that time he has been considering plans for increasing his facilities.

The Fisher Body Corporation, Detroit, the largest automobile body manufacturer in the world, has made arrangements with New York bankers to take \$5,000,000 seven per cent preferred stock and part of the common shares of the corporation. The Fisher Body Corporation is a consolidation of the Fisher Body Co. and the Fisher Closed Body Co., of Detroit, and the Fisher Body Co. of Canada, Ltd. The concern makes bodies for Ford, Cadillac, Buick, Maxwell, Chalmers, Hudson and a number of other cars.

Cars Painted to Suit Buyers

The Barley Automobile Mfg. Co., Streator, Ill., has decided to paint all of the cars manufactured in the future in accordance with the wishes of the buyers. A lengthy list of color combinations has been prepared which is submitted to patrons.

United Motors Buys Brown-Lipe-Chapin Co.

The Brown-Lipe-Chapin Co., Syracuse, N. Y., largest manufacturer of differential gears, has been purchased by the United Motors Corporation.

The general policy of Brown-Lipe-Chapin will be continued as at present, but the capacity of the plant in the manufacture of differentials will be doubled as soon as additional buildings can be erected. President Sloane's name will be added to the board of directors of Brown-Lipe-Chapin, but H. W. Chapin will continue as general manager.

The purchase of the Brown-Lipe-Chapin Co. in no wise involves the Brown-Lipe Gear Co., of Syracuse, which has been very closely connected with Brown-Lipe-Chapin. The latter concern is practically controlled by Messrs. Brown and Lipe, wealthy Syracuse capitalists connected with the Smith-Premier typewriter company. These gentlemen owned approximately one-half of the Brown-Lipe-Chapin stock, the remainder being held by C. W. Mott and his General Motors associates.

This latest purchase gives the United Motors Corporation seven large manufacturing organizations, each of which is continued as a separate manufacturing concern. The list to date includes: Hyatt, New Departure, Delco, Remy, Perlman, Klaxon and Brown-Lipe-Chapin.

Henry Ford on Inspection Tour

Henry Ford, the Detroit automobile builder, recently visited the Edgar Thomson blast furnaces of the Carnegie Steel Co., at Bessemer, Pa., and then spent several days in Youngstown, O., with Julian Kennedy, consulting engineer, Pittsburgh, and others, making an inspection of the blast furnaces, steel works and finishing mills of the Youngstown Sheet & Tube Co. As announced some time ago, Mr. Ford contemplates the building of two large blast furnaces near Detroit, Mich., for which Mr. Kennedy is consulting engineer. It is planned to connect the furnaces with the Ford foundry, so that it will be possible to keep the iron in a molten state from the time it leaves the furnace tap hole until it is poured into the foundry molds.

Bearings on British Embargo List

Ball and roller bearings and steel balls and rollers for bearings have been added to the British list of goods the exportation of which is prohibited to all destinations. Spark plugs have also been included in the embargo list, but these are prohibited from being exported to all foreign countries in Europe and on the Mediterranean and Black Seas, other than France, Russia (except through Baltic ports), Italy, Spain and Portugal.

WANTS

Help and situation wanted advertisements, 1 cent a word; all other advertisements in this department, 5 cents a word; initials and figures count as words. Minimum price, 30 cents for each advertisement.

PATENTS

Patents—H. W. T. Jenner, patent attorney and mechanical expert, 606 F St., Washington, D. C. Established 1883. I make a free examination and report if a patent can be had and exactly what it will cost. Send for circular.

Index To Advertisers

Acme Die-Casting Corporation.....	4
Acme Rubber Mfg. Co.....	42
Anti-Borax Comp. Co.....	Back cover
Barrell Co., Wm. L.....	43
Bliss, E. W. Co.....	3
Bookwalter Wheel Co.....	42
Bradley, C. C., & Son.....	41
Brawley, T. R.....	2
Brennan Motor Mfg. Co.....	4
Cargill Co., The.....	37
Carter, Geo. R., The, Co.....	42
Columbus Bending Co.....	42
Columbus Bolt Works.....	Back cover
Cowles, C., & Co.....	42
Decker, J. C.....	42
Doehler Die-Casting Co.....	4
Dowler, Chas. L.....	42
DuPont Fabrikoid Co.....	39
Eberhard Mfg. Co.....	40
Eccles, Richard, Co.....	39
Fairfield Rubber Co.....	43
Felton, Sibley & Co., Inc.....	Back cover
Hartford Clock Co., The, Inc.....	8
Hoopes Bro. & Darlington.....	43
Hotel Brunswick.....	41
Hotel Cumberland.....	37
International Rubber Co.....	41
Jenner, H. W. T.....	36
Johnston Paint Co.....	42
Keratol Co., The.....	38
Laidlaw Co., Inc.....	38
Meyer, John C., Co.....	2
Millersburg Fifth Wheel Co.....	42
Mulholland Co., The.....	42
Murcott-Duden Co., The.....	8
O'Bannon Corporation.....	38
Parrott Varnish Co.....	42
Payne, E. Scott, Co.....	42
Porter, H. K.....	42
Pressed Steel Co. of New York.....	2
Rome-Turney Radiator Co.....	6
Russel, Burdsall & Ward Bolt & Nut Co.....	41
St. Marys Wheel & Spoke Co.....	2
Sheldon Axle & Spring Co.....	7
Shortsville Wheel Co.....	37
Smith, H. Collier.....	42
Smith Wheel, Inc.....	Front cover
Standard Oil Cloth Co., Inc.....	5
Technical School for Automobile Draftsmen.....	41
Valentine & Co.....	Back cover
West Tire Setter Co.....	43
White-Quehl Mfg. Co.....	42
Wilcox Mfg. Co., D.....	42
Willey Co., C. A.....	37
Williams, J. H., & Co.....	8
Wing, Chas., Co.....	42
Zwick & Greenwald Wheel Co.....	42

WILLEY'S COLORS

The Recognized Standard



C. A. WILLEY CO.

COLOR GRINDERS

and Manufacturers of Specialties in

CARRIAGE, AUTOMOBILE and CAR

PAINTS

COLORS, VARNISHES, ETC.

HUNTER'S POINT, NEW YORK CITY

CONTRACT TIME IS AT HAND

Do not fail to get our prices
before signing up for next year

We can furnish promptly standard Shortsville Wheels

Quality Wheels at Right Prices are
A GOOD INVESTMENT

Write Us

Shortsville Wheel Co.

The Daylight Factory

Shortsville - - New York

HOTEL CUMBERLAND

NEW YORK

Broadway at 54th Street

Near 50th Street Subway Station and 53d Street L



Broadway Cars from Grand
Central Depot.

Seventh Avenue Cars from
Pennsylvania Station.

**NEW AND FIRE-
PROOF**

Best Hotel Accommodations
in New York at Reason-
able Rates.

**\$2.50 with Bath
and Up**

EUROPEAN PLAN

All Hardwood Floors and
Oriental Rugs.

Ten Minutes' Walk to 40
Theatres

Excellent Restaurant. Prices Moderate.
Send for Booklet.

HARRY P. STIMSON

Only New York Hotel window-screened throughout

Catalog Building

Is similar to that of other prod-
ucts. The raw materials, *plus*
expert designing, *plus* competent
workmanship, *plus* the know
how (and we have had over
twenty-five years of the latter),
equal the finished article.

The Cargill Company

Complete Printing Service

Grand Rapids, Michigan

Split Leather

a substitute for and always inferior to

KERATOL

Any
Finish



All
Grains

Nothing but hair grain leather wears better than KERATOL!

SAMPLES AND PRICES UPON REQUEST

The Keratol Co.

South and VanBuren Sts., Newark, N. J.

O'BANNON ARTIFICIAL LEATHER

Reg. U. S. Pat. Off.

Moleskin Quality

The Best Leather Substitute

All the
Standard Leather Grains, Colors and Finishes

GUARANTEED

Against Cracking, Peeling or Wearing Down
to the Cloth Backing

WRITE FOR SAMPLES

O'BANNON CORPORATION

200 Fifth Avenue, New York City

The Caidlaw Company Inc.

New York City

AUTOMOBILE FABRICS

A Fabric For Every Purpose

For Closed, Open or Convertible Bodies



Top Material

is a single texture, light weight, strong and pliable, water and weather proof topping sincerely guaranteed for one year's service, but made to last the life of the vehicle.

Top your vehicles with RAYNTITE — the widely advertised, warranted fabric.

Motor Quality Fabrikoid is the standard seat upholstery.

Samples sent on request.

Du Pont Fabrikoid Co.

WILMINGTON, DEL.
TORONTO, ONT.

High Grade Forgings

for CARRIAGE, WAGON, AUTO-MOBILE and SPECIAL WORK

ECCLES BALL-BEARING COUPLINGS are the BEST on the MARKET for DURABILITY and EASE OF ADJUSTMENT

LEATHER BUSHINGS ARE FASTENED IN THE SOCKET WHERE THEY BELONG



Patented Nov. 25, 1902, and June 11, 1907

SPECIAL FEATURE—THE SPRING IS PIVOTED AT THE FRONT TO ALLOW EASY ADJUSTMENT.

Please bear in mind that we make a FULL LINE of Carriage and Wagon Forgings, also many of those for Auto and Special Work.

Send for our new Catalogs showing our Regular and Special Forgings.

QUALITY GUARANTEED. SERVICE—THE BEST

Richard Eccles Co.

AUBURN, NEW YORK

CLASSIFIED INDEX

For Addresses See Alphabetical Index and Advertising Pages

AUTO FABRICS

Acme Rubber Mfg. Co., Trenton, N. J.
Barrell, Wm. L., Co., New York
Laidlaw Co., Inc., The, New York

AXLES (Including Ball and Roller Bearing)

Sheldon Axle & Spring Co., Wilkes-Barre, Pa.

BOLTS AND NUTS

Columbus (O.) Bolt Works Co.
Russell, Burdall & Ward Bolt & Nut Co., Port Chester, N.Y.

BOLT CLIPPERS

Porter, H. K., Everett, Mass.

BRAZING SLEEVES

White-Quehl Mfg. Co., Cincinnati, O.

CLOCKS

Hartford Clock Co., Inc., New York City.

DIE CASTINGS

Acme Die Casting Corp., Brooklyn, N. Y.
Doehler Die Casting Co., Brooklyn, N. Y.

FIFTH WHEELS

Millersburg Fifth Wheel Co., The, Millersburg, Pa.
Wilcox Mfg. Co., D., Mechanicsburg, Pa.

HARDWARE (Carriage, Wagon and Automobile)

Columbus (O.) Bolt Works Co.
Dowler, Chas. L., Philadelphia.
Eccles Co., Richard, Auburn, N. Y.
Wilcox Mfg. Co., D., Mechanicsburg, Pa.
Wing Co., Chas., Amesbury, Mass.
Cowles, C., & Co., New Haven, Conn.
Payne Co., E. Scott, Baltimore.

LEATHER SUBSTITUTES

Barrell Co., Wm. L., New York.
International Rubber Co., New York City.
Keratol Co., The, Newark, N. J.
O'Bannon Corp., New York.
Standard Oil Cloth Co., New York.
DuPont Fabrikoid Co., Wilmington, Del.

MACHINERY AND TOOLS

Bliss Co., E. W., Brooklyn, N.Y.
Smith, H. Collier, Detroit, Mich.

West Tire Setter Co., Rochester, N. Y.
Williams, J. H., & Co., Brooklyn, N. Y.
White-Quehl Mfg. Co., Cincinnati, O.

MACHINERY (Metal Working)

Bliss Co., E. W., Brooklyn, N.Y.
Smith, H. Collier, Detroit, Mich.

METAL STAMPINGS AND NOVELTIES

Murcott-Duden Co., Inc., New York.

PATENTS

Jenner, H. W. T., Washington, D. C.

PAINTS AND COLORS

Felton, Sibley & Co., Inc., Philadelphia, Pa.
Johnston Paint Co., R. F., Cincinnati, O.
Sherwin-Williams Co., Cleveland, O.
Valentine & Company, 456 4th Ave., New York; 343 S. Dearborn St., Chicago; 74 Pearl St., Boston.
Wiley Co., C. A., Hunter's Point, N. Y.

PASTE

Indianapolis (Ind.) Paste Co.

SCHOOL FOR DRAUGHTSMEN

Mechanics' Institute, New York

SHAFT COUPLINGS

Bradley & Son, C. C., Syracuse, N. Y.
Eccles Co., Richard, Auburn, N. Y.

SPRINGS

Mulholland Co., Dunkirk, N. Y.
Sheldon Axle & Spring Co., Wilkes-Barre, Pa.

THREADS

Meyer, Jno. C. & Co., Lowell, Mass.

VARNISH AND JAPAN

Felton, Sibley & Co., Inc., Philadelphia, Pa.
Parrott Varnish Co., Bridgeport, Conn.
Sherwin-Williams Co., Cleveland, O.
Valentine & Company, 456 4th Ave., New York; 343 S. Dearborn St., Chicago; 74 Pearl St., Boston.
Wiley Co., C. A., Hunter's Point, N. Y.

WELDING COMPOUND

Anti-Borax Compound Co., Ft. Wayne, Ind.

WHEELS

Bookwalter Wheel Co., Miamisburg, O.
Hoopes Bros. & Darlington, Inc., West Chester, Pa.
St. Mary's Wheel & Spoke Co., St. Mary's, O.
Shortsville (N. Y.) Wheel Co.
Zwick & Greenwald Wheel Co., Dayton, O.

WOOD BENDINGS, WHEEL STOCK, ETC.

Columbus (O.) Bending Co.
St. Mary's Wheel & Spoke Co., St. Mary's, O.
Shepard, H. G., & Sons, New Haven, Conn.



SERVICE—QUALITY

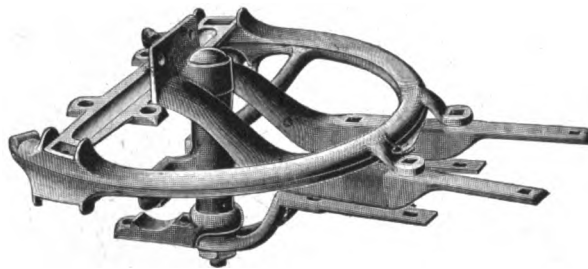

THE EBERHARD MANUFACTURING CO.

CLEVELAND, OHIO



The Only One-piece Moulded Leather Packing

The Bradley Carriage Coupler

All-Steel Noiseless Quick-Shifting Ball-Bearing

(MADE IN FIVE SIZES FOR AXLES 1/4 INCH TO 2 1/4 INCH)

The only carriage coupler that is furnished with a ONE-PIECE MOULDED LEATHER PACKING

C. C. BRADLEY & SON, Syracuse, N. Y.



The Bradley Carriage Coupler

Vehicle Mechanics

Desiring to improve their present Condition should attend the

TECHNICAL SCHOOL

For

Automobile Draftsmen and Mechanics

Supported by the

The National Automobile Chamber of Commerce, Inc.

The object of the School is to teach men to design vehicles and make working drawings, and to otherwise facilitate their work in the shop. Only those men employed in carriage or automobile building or their accessory trades are admitted to its privileges.

The classes are conducted in three divisions, viz.: Corresponding, Day, and Evening. The former is open during the entire year, while the day and evening classes are in session only from October 1 to April 1.

The tuition is moderate.

For prospectus and full particulars, write to the instructor.

ANDREW F. JOHNSON,
20 West Forty-fourth St.,
NEW YORK CITY

THE BRUNSWICK



Boylston Street, Corner Clarendon,
(Facing Copley Square)

BOSTON - - MASS.

High class modern house, intelligent service, pleasant rooms, superior cuisine. Ladies traveling alone are assured courteous attention. European plan, single rooms, \$1.50 up; with bath, \$2 up; double, \$2 up; with bath, \$3 up. American plan, \$4 per day up.

FRED E. JONES - Proprietor

RUSSELL, BURDSALL & WARD BOLT & NUT CO.

Established 1845

PORT CHESTER, N. Y.

MAKERS OF THE CELEBRATED EMPIRE BOLTS AND NUTS

Western Office: Continental & Commercial Bank Bldg., Chicago, Ill. Branch Works: Rock Falls, Ill.

"INTERNATIONAL" RUBBER CARRIAGE CLOTH

The Rubber Carriage Cloth of SERVICE and QUALITY
INTERNATIONAL RUBBER CO.

Write for Samples and Prices
120 Broadway, New York

BUSY BUYERS BRIEFS

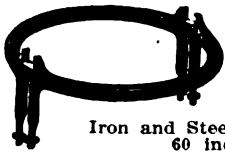

Manufacturers
FIFTH WHEELS
All Varieties
Heavy Goods a Specialty
Iron and Steel Rings from 4 to 60 inches wide
MILLERSBURG FIFTH WHEEL CO.
Millersburg, Pa.

The Zwick & Greenwald Wheel Co.

High Grade Vehicle
WHEELS

DAYTON - - OHIO

WE MANUFACTURE
FINE VEHICLE
WHEELS

The Bookwalter Wheel Co.
MIAMISBURG, OHIO

**JOHNSTON'S
KRAKNO**

Color Card Free
\$3.50 per gallon

The R. F. Johnston Paint Co.
Cincinnati, Ohio

THE CHARLES WING CO.

Established 1848

Manufacturers and Wholesale Dealers in
**AUTOMOBILE AND CARRIAGE
HARDWARE AND TRIMMINGS**
AMESBURY, MASS., U. S. A.



The **PARROTT
VARNISH CO.**
BRIDGEPORT, CONN.
Automobile, Coach and Wagon
VARNISHES
and VARNISH REMOVER

Columbus Bending Co.

Successors to The Wildermuth Bending Co.
COLUMBUS, OHIO

Manufacturers of **BENT RIMS**

For Wagon, Carriage and Auto Wheels

Why Not Have the Best?



One of a Large Variety

G. Cowles & Co.
NEW HAVEN,
CONN.

J. C. DECKER

MONTGOMERY, PA.

Manufacturer of

Carriage, Skate and Pad Straps

Side Loops, Bridle Fronts, Tail Ties, etc.

SUBSCRIBE FOR
THE HUB
\$2 PER YEAR

E. SCOTT PAYNE CO.
Carriage and Automobile
HARDWARE

Horse - Shoers' Supplies
362-364 North Gay St., Baltimore, Md.

CHARLES L. DOWLER

CARRIAGE AND WAGON HARDWARE

108 North Third St., Philadelphia, Pa.

CUSHION MANUFACTURER

Pure Stearic Acid Candles. Wheel Stock. Snow
Flake Auto Grease.

**Automobile and Carriage Leathers,
Leather Welts and Gimps**

All Kinds of Leather Specialties
WRITE US FOR PRICES

THE GEO. R. CARTER CO.
CONNERSVILLE, IND.

**MULHOLLAND
BUGGY SPRING**

Reduces weight of springs one-half.
Made in one size only but will fit bodies
of all widths.

Write for further particulars and prices.
THE MULHOLLAND CO. DUNKIRK, N. Y.

White's Brazing Sleeves

For applying Rubber Tires
Send for Samples.

WHITE-QUEHL MFG. CO.

431 E. Pearl St.
CINCINNATI, OHIO

WILCOX

FINE
FINISHED
FORGED

**CARRIAGE HARDWARE
AND GEAR IRONS**

Write for Prices and Catalog

The D. Wilcox Mfg. Co.

MECHANICSBURG, PA.

Acme

means

Highest Quality

in

Rubber Carriage Cloths

Acme Rubber Mfg. Co., Trenton, N. J.

PORTER'S BOLT CLIPPERS

"Easy" "New Easy" Allen-Randall



To Cut 5-16, 3-8, 1-2, 5-8, 3-4 Inch.

H. K. PORTER, EVERETT, MASS.

"Quickwork"

Sheet Metal
Working Machinery

For Automobile and Carriage Bodies, Fenders, Hoods, etc.

H. COLLIER SMITH

807-815 SCOTTEN AVE. DETROIT, MICH.

HOOPES BRO. & DARLINGTON

(INCORPORATED)

WEST CHESTER, PA.

WE ARE MAKING

AUTOMOBILE WHEELS

Forty Years' Experience as WHEEL MAKERS is guarantee we can make good ones.
Will not make any other kind. Try them.

The "Rochester" Helve Hammer

was originally designed especially for the Carriage and Wagon making trade

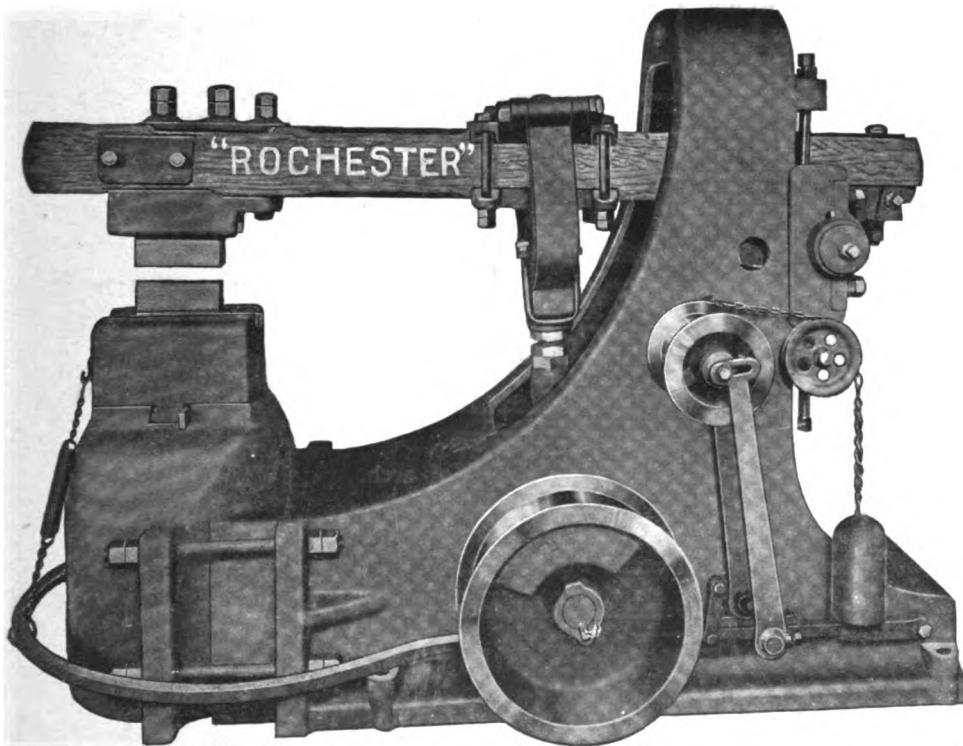

It is highly efficient and sold at a reasonable price. Built in two types of frame and six sizes—25 lb. to 100 lb. head. Furnished with dies set lengthwise or crosswise of helve as desired. A fine hammer for welding tires.

Send for our catalog and prices.

... The ...

West Tire Setter Co.

Rochester, N. Y.

THE FAIRFIELD RUBBER COMPANY

Manufacturers of

Carriage Cloth, Imitation Leather,

Automobile Cloths, etc.

FAIRFIELD,

CONNECTICUT



QUALITY

Automobile Top Fabrics
and Cotton Duck

WRITE FOR SAMPLES

WILLIAM L. BARRELL COMPANY
NEW YORK

Valentine's Painting Materials

Valentine's varnishes are the highest grade vehicle varnishes made—that is, the most brilliant, most easily used, and most durable.

Also, they are of necessity the most expensive; by using them the makers of all the best automobiles and carriages show that they pursue the

policy of equipping their products with the best materials, whatever their cost.

Owners of automobiles and carriages should ask for Valentine materials when having them re-finished. Any vehicle painter will use them if specified. Most painters use them regularly.

Write for our book, "The Care of the Car"



Valentine & Company

Largest Manufacturers of High Grade Varnishes in the World

456 Fourth Ave., New York 343 S. Dearborn St., Chicago 74 Pearl St., Boston



"E-Z" Welding Compound is the best for general welding.

Because it sticks to the metal at a low heat.

Because it makes perfect welds at fully 250 degrees lower heat than any other.

Because it does not boil up and waste while fluxing.
Because it prevents slipping of laps.



CRESCENT Welding Compound is the best substitute for borax known. It is particularly good for welding under dies

and where parts are fastened together before welding, like Toe Calks, etc.

FOR SALE BY ALL JOBBERS
Samples Sent Free

Manufactured only by

ANTI-BORAX COMPOUND COMPANY, Fort Wayne, Ind.

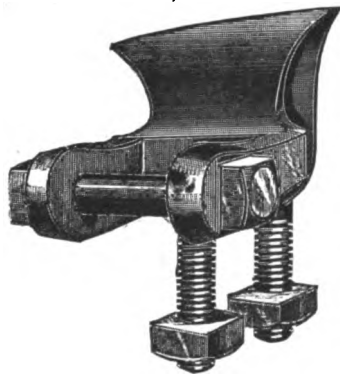

Skewed Shaft Couplings

**Regular or Oval Patterns
For High Arched Axles**

Furnished in rights and lefts for any height of arch.
Oval Axle Clips $\frac{5}{8}$ or $\frac{3}{4}$ width to match Oval Couplings. Bolts, Clips, Couplings, Carriage Hardware and Special Forgings

Catalogue "H" and Prices on Application

COLUMBUS BOLT WORKS COMPANY

COLUMBUS, OHIO

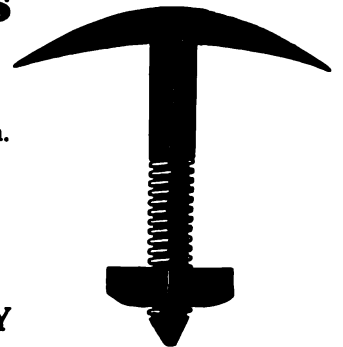

"F-S" Products Hold Their Own Against All Comers

Many coach, wagon and automobile manufacturers haven't been without a supply of "F-S" Raven Gloss Carriage Paint in their shops for years. It always gives a good, durable job. Ready for the brush and, when applied over the same shade, requires but one coat.

FELTON, SIBLEY & CO., Inc.

Manufacturers of
Colors, Paints and Varnishes since 1863

136-140 North Fourth Street
PHILADELPHIA

The Hub

First Journal of the Vehicle Industry

Vol. LVIII

NEW YORK, NOVEMBER, 1916

No. 8

SHELDON

"The Name Internationally Famous"

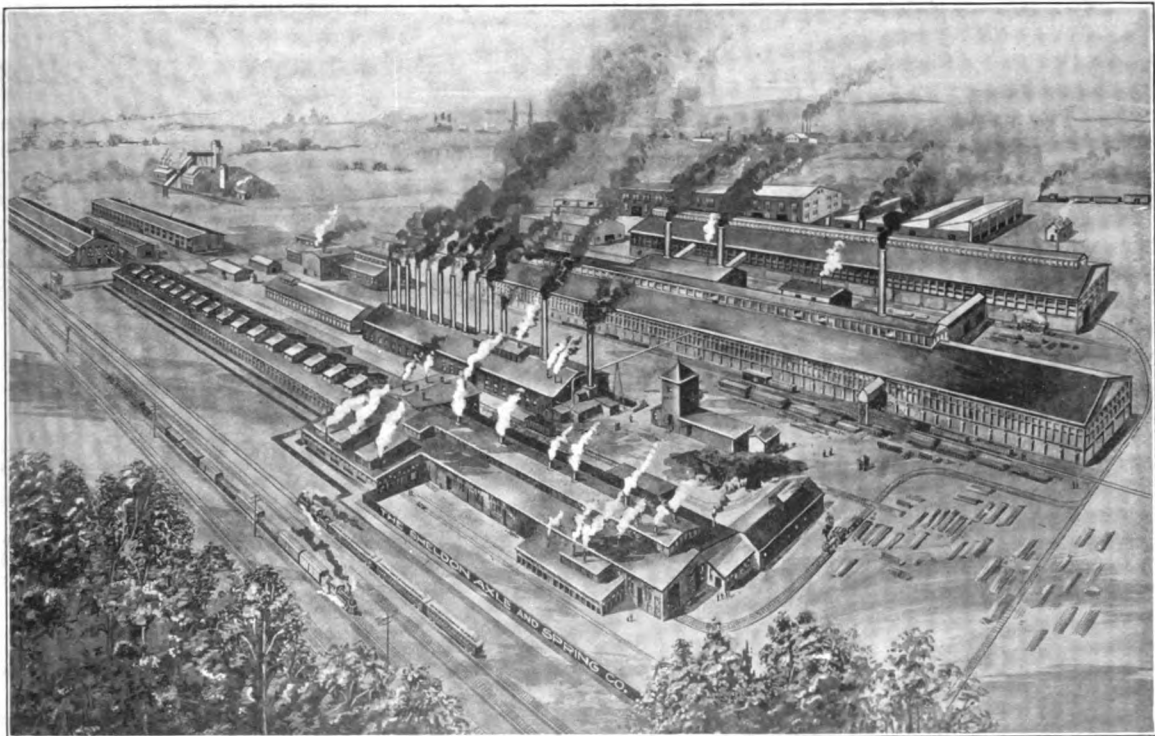

SPRINGS AND AXLES

Sheldon Axle and Spring Company

Wilkes-Barre, Pa., U. S. A.

Buy "Hickory Nut," "Acorn" Vehicle Wheels

You cannot buy better wheels dollar for dollar paid. A bad wheel is a big "Leak" in your business.

STOP THAT LEAK TODAY
By Asking Your Jobber for
WHEELS "MADE IN ST. MARYS"

Export Office: 8 Bridge St., NEW YORK CITY
Factories: ST. MARYS, O.; RICHMOND, VA.

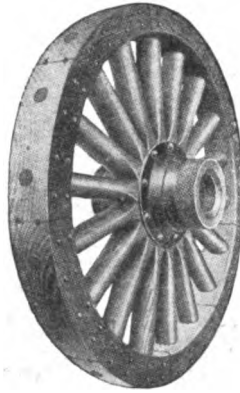

and "Star" Brand Carriage Woodstock

We make a specialty of Spokes, Hubs, Bent Hickory and Oak Rims, Poles, Shafts, Singletrees, etc., for **New Work or Repairs.**

Buy "Star" Brand and be a satisfied customer.

INSIST ON OUR BRANDS

St. Marys Wheel & Spoke Co.
Consolidated with CRANE & MacMAHON, Inc.
ST. MARYS, O. :: U. S. A.

steel stampings

especially for
COMMERCIAL TRUCKS

The Pressed Steel Co. of N. Y.
141 Broadway

CONTRACT TIME IS AT HAND

**Do not fail to get our prices
before signing up for next year**

We can furnish promptly standard Shortsville Wheels

**Quality Wheels at Right Prices are
A GOOD INVESTMENT**

Write Us

Shortsville Wheel Co.

The Daylight Factory
Shortsville - - New York



85-87 ADAMS ST.
BROOKLYN, N.Y.

Felts for the Automobile and Machinery Trades a Specialty
DUST RINGS FOR HUBS **STRIPS FOR CRANK CASES**
FELT WASHERS AND GASKETS FOR ALL LUBRICATING AND DUST EXCLUDING PURPOSES
No order too small to receive prompt and most careful attention



MEYER THREADS

**CAN BE HAD
IN ANY SIZE
OR COLOR
THAT IS
WANTED**

**Send in your
orders at once**

**JOHN C. MEYER
THREAD WORKS
LOWELL, MASS.**

There is a size that will successfully meet your exact requirements

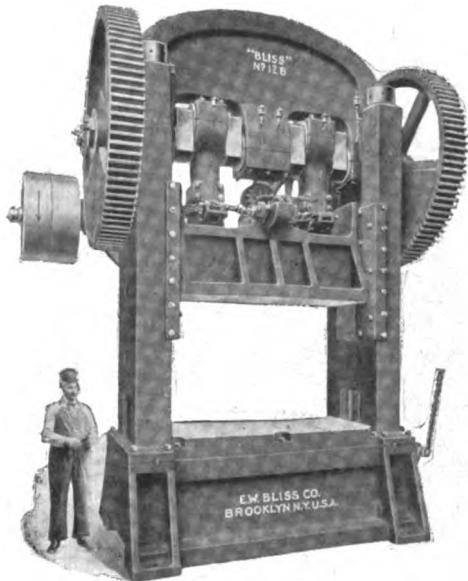

Presses with correct proportions for use in the manufacture of large sheet iron and steel goods. The large diameter shafts and well-gibbed sides allow quantity production that's profitable.

Bliss Double-Crank Presses

Adapted for the economical production of vapor stoves, wrought iron ranges, agricultural implements, automobile stampings, steel car parts, ceilings, sidings, metal doors, window frames and sashes, metal furniture and similar goods.

Built in over 150 sizes, there is one adapted to your special requirements. Write today for descriptive matter.

Talk to us about presses for any and every requirement

E. W. BLISS CO

38 Adams St., Brooklyn, N. Y.

Chicago Office: 622 West Washington Boulevard
Detroit Office: Dime Bank Building.



We Emphasize Quality and Service

Manufacturing Engineers

Body Hardware

Tools

Dies

Metal Stampings

Automobile Parts

Electric Welding

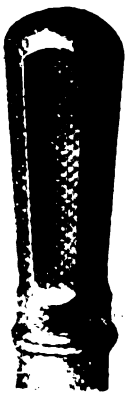

No. 4
Lever
Handle

Our No. 39 Concealed Door Hinge has taken the lead on merits alone. There are millions of them in use.

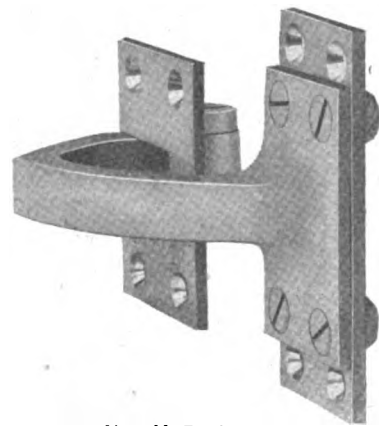

No. 44 Deck Hinge



Detroit, U. S. A.

DOEHLER DIE-CASTINGS

are used with the utmost confidence and in ever-increasing quantities by the leading manufacturers in nearly every branch of the metal working industries.

The economical advantages derived from the use of die-castings, delivered in a finished state practically, over parts produced by machining methods, are clearly apparent. The use of "DOEHLER Die-Castings insure a realization of every advantage because of the excellence of the "DOEHLER" quality and reliability of the "DOEHLER" service.



Aluminum Die-Cast
Magneto Housing

DOEHLER DIE-CASTING CO.
BROOKLYN, N. Y.
NEWARK, N. J. TOLEDO, OHIO.

ROME-TURNEY (TRUCK TYPE) RADIATOR COOLING SECTIONS

ARE INSURED FOR THE LIFE OF THE ENGINES

Built of Seamless Copper, Helical Tubes and Heavy Copper Top and Bottom Plates. They are practically indestructible in normal service. Every Rome-Turney Truck-Type Radiator Cooling Section is sold with this written guarantee of quality. It is radiator insurance in every sense.

No. _____

"Radiator Insurance"

**ROME-TURNEY
RADIATOR COMPANY**
of ROME, NEW YORK

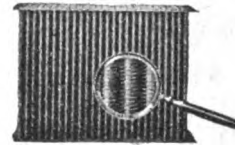

Guarantees

The Seamless Helical Tube Cooling Section Number _____
installed on _____ ton truck, made by _____

FOR THE LIFE OF THE MOTOR NUMBER _____
This guaranty is unreserved, except as against accidental injury or freezing. If the cooling section develops leaks we will repair it free of charge.

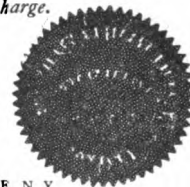

Dated at ROME, N. Y.
this _____ day of _____ 19__

W. L. KINGOLEY, President
BARTON HAMILTON, Vice-President
Geo. W. TURNEY, Treasurer-General Manager
W. L. LYNCH, Secretary

Rome-Turney radiator cooling sections are constructed of seamless copper helical tubes, of which we are exclusive makers, and they are designed to exact proportions. The workmanship is as close as that on the highest priced engine. The radiating results are absolutely certain and endurance is almost unlimited.

Rome-Turney units represent extremely advanced engineering. We have built radiators of all types for 14 years and are specialists in designs developed for truck construction. No better radiators can be built. If this were possible we would build them.

Fullest Information Will Be Supplied at Request.
Correspondence Is Invited.

ROME-TURNEY RADIATOR CO.
ROME, NEW YORK

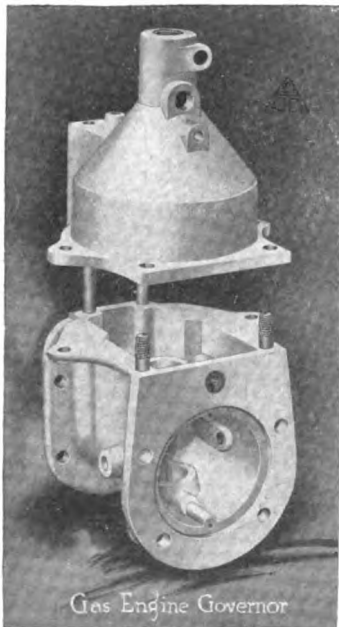

Gas Engine Governor

Examine an ACME Die- Casting

Test it in every way. Note the close-grained, homogeneous metal, the accuracy, the consistency of the product, and the beautiful finish. The illustration is an example of what we are doing for others. Come to our factory, if you can, and see the character of the work we are shipping. You would need no more convincing argument of the fact that we can aid vehicle makers to derive the utmost benefit from the Die-Casting process. Send blue prints or models for estimates.

Acme Die-Casting Corporation

Bush Terminal Bldg. No. 5 35th St. and Third Ave.
BROOKLYN, N. Y.

SALES OFFICES:

Boston—176 Federal St. Chicago—549 Wash. blvd
Philadelphia— Widener Bldg. Detroit— 965 Woodward Ave.

CANADIAN DISTRIBUTORS:

Lyman Tube & Supply Co., Ltd., Montreal



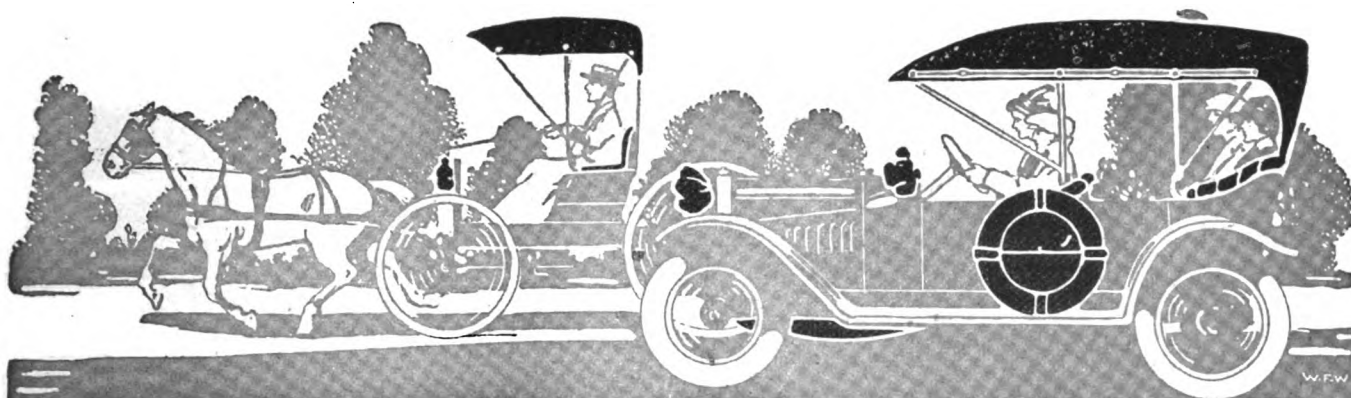

The Leading Leather Substitute For Carriage and Auto Trade

When you need a leather substitute, join the other progressive carriage and automobile manufacturers and select the leading leather substitute—

MERITAS

LEATHER CLOTH

A leather substitute is but a substitute after all—but Meritas leather cloth is made and finished to withstand the hardest wear and handling.

Meritas Leather Cloth is durable, of non-cracking finish and guaranteed perfect by our trademark stamped on the back of every yard. You will like the selection of colors and the lasting finish of this serviceable leather substitute.

Meritas Leather Cloth is made in muslin, duck and drill; dull or glazed; smooth or grained; in black and colors.

Learn more about this leading leather substitute by writing for sample book—sent on request.

Write
for
sample
book of
MERITAS
LEATHER CLOTH
NOW

The Standard Oil Cloth Co., Inc.

320 Broadway, New York

COMMENTS

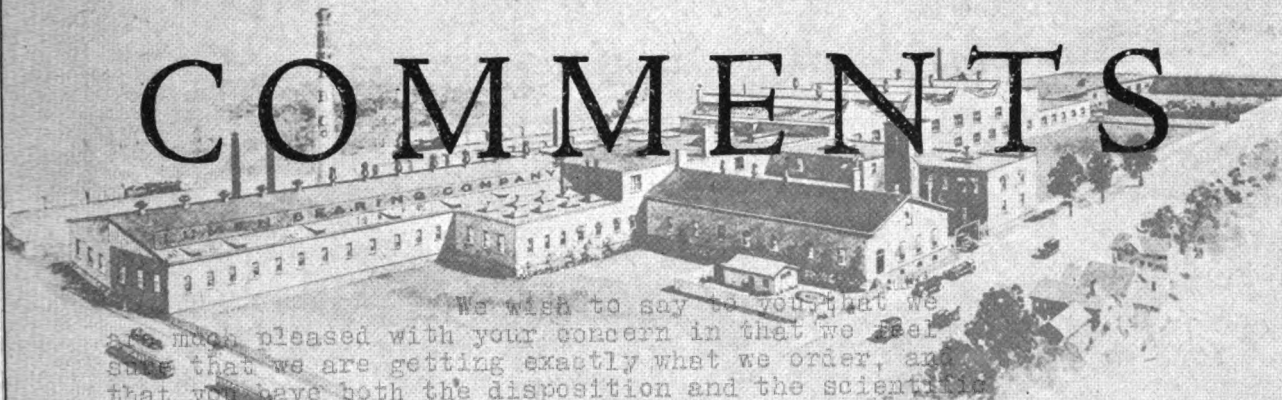

We wish to say to you that we are most pleased with your concern in that we feel sure that we are getting exactly what we order, and that you have both the disposition and the scientific means of duplicating your product. The bearing bronze that we are using at present, so far as the light of our experience has taught us, is the best we have ever used.

QUALITY

In the past we operated a brass foundry making our bronze and brass castings at our factory, but the excellent quality of the castings and the prompt service given us by your company made it much to our advantage to shut down our own foundry and to place our orders with you.

ECONOMY

We are however pleased to state that we have used this metal continuously for the past ten years in making the most important bearings for the machines we build. Judging from our own experience and reports from customers using our machines, we believe you are furnishing material that we need not hesitate to put into the construction of the high grade machinery which we endeavor to manufacture.

CONFIDENCE

THE *Quality* of our castings and the *Economy* derived from their use will inspire your *Confidence* in our product.

We will gladly send you complete letters from which the above comments are taken, upon request.

LUMEN BEARING COMPANY

BRASS FOUNDERS

BUFFALO

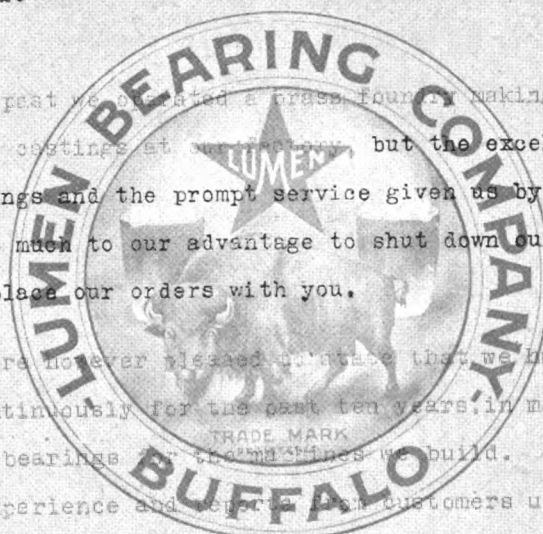



SEAMLESS TUBING STEEL—BRASS—COPPER

Send Us Your Specifications
for Rush Requirements

MURCOTT-DUDEN CO., Inc.
253 Broadway New York



Meet me at the Tuller for Value, Service, Home Comforts

NEW HOTEL TULLER Detroit, Michigan

Center of business on Grand Circus Park. Take Woodward car, get off at Adams Avenue.

ABSOLUTELY FIREPROOF

200 Rooms, Private Bath, \$1.50 Single, \$2.50 Up Double				
200 " " " 2.00 " 3.00 " "				
100 " " " 2.50 " 4.00 " "				
100 " " " 3.00 to 5.00 " 4.50 " "				

Total, 600 Outside Rooms

ALL ABSOLUTELY QUIET

Two Floors—Agents' Sample Rooms

New Unique Cafes and Cabaret Exellente

Drop-Forged Tools for the Machine Shop

Suitable Design,
Dependable
Construction,
Sufficient Performance

Safety, Strength, and
Ultimate
Economy
Back Up Our Guarantee

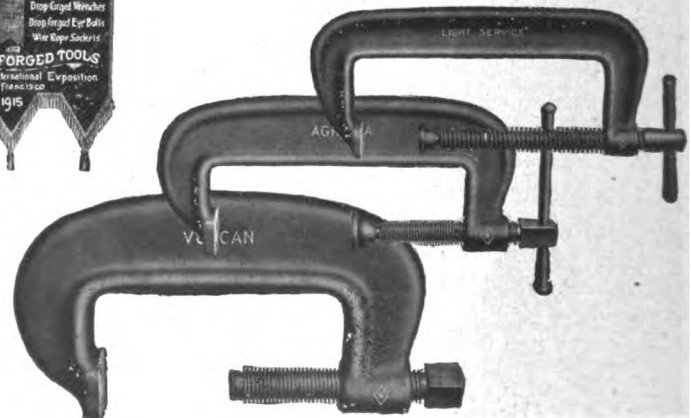

REQUEST MACHINISTS'
TOOLS PAMPHLET FOR
FULL DETAILS

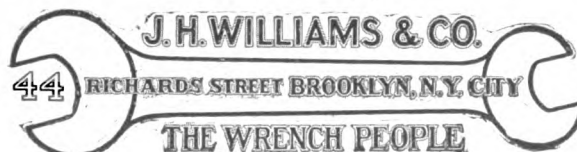

LEADING DEALERS
SUPPLY ALL "VULCAN"
AND "AGRIPPA" TOOLS

Please mention "The Hub" when you write

The Hub

INCLUDING Carriage and Wagon Builder and American Vehicle

Vol. LVIII

NEW YORK, NOVEMBER, 1916

No. 8

Published Monthly by

THE TRADE NEWS PUBLISHING CO. OF N. Y.

PAUL MORSE RICHARDS, *President* G. A. TANNER, *Secretary and Treasurer*
EDISON BUILDING, COR. ELM AND DUANE STS., NEW YORK

THE HUB, a monthly authoritative journal on all subjects pertaining to the vehicle industry from its engineering and construction viewpoints. It publishes information of live interest to manufacturers of motor vehicles, trailers, carriages, wagons, the accessory trades, repair shops and garages.

Subscription price for the United States, Mexico, Cuba, Porto Rico, Guam, the Philippines, and the Hawaiian Islands, \$2.00; Canada, \$2.50; payable strictly in advance. Single copies, 25 cents. Remittances at risk of subscriber, unless by registered letter, or by draft, check, express or post-office order, payable to the order of THE TRADE NEWS PUBLISHING CO.

For advertising rates apply to the publishers. Advertisements must be acceptable to publishers. Copy for new advertisements must be received by the 25th of the preceding month. All communications must be accompanied by the full name and address of writer.

Entered in the New York Post Office as Second-class Matter

Reason for Well Built Roads

A news item to the effect that a company has been formed to operate a line of heavy motor trucks between New York City and points in New Jersey, for the hauling of freight and general merchandise manufactures, is particularly of interest because of the fact that it is just this sort of traffic that wears out our good roads so quickly that they are almost always in need of repair. The company referred to will put in service about 100 trucks with the object of providing additional facilities for those firms which experience congested freight service on the railroads. It is an argument for the building of better trunk-line roads between cities of importance and throughout the country generally.

Good roads are numerous throughout the section of the country contiguous to New York City, but as a matter of fact there are many of these roads that could, and should, have been built in a much better manner. There are, many of them, roads that will never stand up under the strain of continued heavy traffic, in all weathers. Those people who have been urging the construction of better highways, and all organizations and individuals interested, should wage a strong fight for the establishment of specifications that will result in a standard of durability for road building throughout the states.

Commendable Move by S. A. E.

It is quite certain that much interest will be centered on the efforts of the S. A. E. to evolve a set of specifications for an ideal army truck. As a matter of fact, there have always been enough obstacles in the way of an engineer to prevent the production of an ideal truck, of the capacity specified in the preliminary requirements, sug-

gested by the society. The new step is a notable one in the advance of the S. A. E., and much credit is due those who have started this new movement. It may well be expected that there will be worked out some efficiency details that have so far been lacking in the small truck field, more especially for those vehicles intended for such severe work as army trucks are put to. There is room for much improvement and there seems to be no reason why concerted effort should not result in the realization of something far above present attainments in the industry.

Molybdenum as a Steel Alloy

The business of producing alloy metals, though a virgin field, has sprung into especial prominence because of the necessity of husbanding the supply of iron. The steady advance in the price of ore gives the strongest evidence of the increasing scarcity of this metal; and the greatest economy in prospect is the use of the rare mineral alloys which produce such a radical increase in strength coupled with reduction in weight of material consumed. The use of tungsten and vanadium in this connection is more or less of an old story; and the producers of molybdenum now claim for it a future far outreaching that of either of its competitors.

It is stated that the great guns with which Germany did such destruction when her artillery preparation took the world by surprise in 1913 were molybdenum guns; that, containing three to four per cent of this substance, their life was 20 times that of the ordinary gun. It is estimated that at the present market price the use of a 3¼ per cent molybdenum alloy would increase the cost of a 12-inch gun about 25 per cent, while increasing its useful life 2,000 per cent. And in rifle barrels for high power powder, the strength can be increased even though the weight be materially reduced.

In the form of molybdenite—the disulphide—and wulfenite—the molybdate of lead—this metal is found in Colorado, Arizona, Washington and Maine, and extraordinary deposits are being uncovered in the province of Ontario, so that for it, at least, we shall probably not have to depend upon European sources of supply.

Demand for Autos in Straits Settlements

The demand for American automobiles in the Straits Settlements, according to Consul Harry Campbell, Singapore, has steadily increased and there is reason to believe that the American car has found a permanent place in this market. The shortage in the supply from Europe at a time of prosperity in that country has inevitably resulted in a demand for cars of American manufacture. There were many moderate priced cars on sale during the latter

part of the year and the available supply can not fill the demand. Traveling representatives of American cars who have called at Singapore report that their cars are all sold out in advance and that sales are only limited by inability to secure shipping space for delivery here, notwithstanding the high freight charges.

Farm Wagon Standardization

At the annual meeting of the National Implement and Vehicle Association, held at Atlantic City, October 18-20, the activities of the farm wagon department were enumerated in a report submitted by the president of the department, E. E. Parsonage.

"At the beginning of our year's work," says the report, "standardization of farm wagons was well under headway. Most of the old style wood stocks are exhausted, and practically all factories are now shipping standardized styles exclusively. Reports from dealers who have received the new style wagons are most favorable. Traveling salesmen as a general rule advise that they are not handicapped on account of the changes.

"Two widths, i. e., 4 ft. 6 in. narrow and 5 ft. wide, have been agreed upon out of a variety of 12 widths in use. The special committee will continue to co-operate with the roads bureau of the Department of Agriculture, officials of the automobile association, and Carriage Builders' National Association, with the view of ultimately arriving at one track only for all wagons.

"The special tire committee is now active in directing legislation toward the establishment of a schedule of tire widths to be gauged by capacity of the vehicle. The accomplishment of this will be of great benefit in conserving road beds, preventing their deterioration, resulting in great saving to the tax payers.

"Conditions made it necessary in standardization plans to settle upon two wheel heights on farm and mountain wagons. On one-horse wagons it was determined to go a little further, and at the meeting of November 30, 1915, resolved to eliminate all heights of one-horse wagon wheels except 40-44, this to take effect July 1, 1917.

"Standardization of farm trucks is well under way. Nearly all manufacturers of trucks have signified their willingness to conform to plans now outlined.

"We have from time to time given consideration to the rapid increase in costs of material and production. This study has resulted almost universally in recognizing the imperative necessity of adjustments in selling prices, and the steps taken to that end by individual manufacturers have been means of promoting more intelligent competition.

"Consideration has been given to army transport wagons and the results taken up with the War Department as to the advisability of changing their specifications for army wagons so as to utilize stocks of materials regularly carried by various wagon manufacturers. In times of emergency this will expedite the filling of orders and provide the government a greater source of supply.

"A great deal has been accomplished by exchanging views between all members in the direction of shortening up all wagon terms and improving general selling conditions.

"There has been no material decrease in the annual requirements for farm and freight wagons, such as we manufacture, although we will have to admit that the number of farm trucks have increased, and there is some

change in the volume of standard farm wagons. The motor has made no such inroads into our line of business as it has in horse-drawn pleasure vehicles, and until good roads are more general than now we are not likely to see the rapid abandonment of wagons and trucks as now constructed, for there is no vehicle that yields more service for the investment.

"There is, therefore, no reason why our line intelligently handled through the general direction of this department of the association should not continue for many years to come to be both fairly profitable and as satisfactory as any other line of manufactured commodity. Every member should strictly adhere to the standardization recommendations and resist every influence that would turn back this progress and cause him again to indulge in the manufacture of needless variety.

"There are other steps in standardization yet to be considered, and these together with the gradual shortening of terms, will repay all the energy and effort we put into it."

British Trade Combine Reported

"An important item of news," says Light Car and Cycle-car, London, England, "is the statement that several big munition concerns are about to pool their capital to the extent of £30,000,000 (\$145,995,000), and sink their identity in a combine. That this will embrace a section of the motor trade is almost certain, and, as the object is to combat foreign trade after the war, its influence upon the motor industry is obvious. It will be suggested that such a pooling of interests will enable the problem of the cheap car with a gigantic output to be tackled as has never before been possible, but so far as we can ascertain at present it does not seem to any appreciable extent to affect the manufacture of light cars, which is likely to be the biggest side of the motor industry after the war. It is early yet to speculate on the ultimate result, however, and the scheme will be watched with the greatest interest.

"The manufacturers of this country will undoubtedly be faced with some very big problems after the war, and it may be that we shall have to Americanize our manufacturing methods."

Germany Fears American Invasion

The *Automobil Welt*, a Dutch motor paper, recently devoted columns of matter regarding the American invasion which is anticipated in Germany after the war. According to the writer, the German motor trade will be quite able to deal with the demand for higher powered cars, but it is extremely doubtful regarding smaller and cheaper cars. The light cars have never been so necessary as they will be after the war, and it is hoped, therefore, that the German manufacturers will be able to give quick delivery in order to prevent the anticipated influx of American cars immediately peace is declared.

Cast vs. Malleable

Do not mistake malleable iron, which is used in rear housings and other parts of an automobile, for cast iron. It cannot be welded with cast iron. Use care in welding any cast iron which has been previously brazed. Make certain that all brass is removed before starting to weld, and if this is impossible, scrape out the weld as much as possible while adding the welding rod.

Aluminum in Modern Automobile Construction

By James E. Diamond*

Aluminum in nature is more abundant than any other metal, constituting as it does, 8 per cent of the earth's crust. It is the basic metal of all clays, although not all clays readily lend themselves to reduction. But three of these clays deserve to be classed as ores of aluminum—bauxite, cryolite, and corundum. Of these bauxite ranks first in importance, since it can be refined with greater facility than either of the others.

The first step in the reduction at the refinery is determined by a peculiarity in the metallurgy of aluminum. With the ores of most other metals it is necessary simply to concentrate and separate the true ore from the gangue by mechanical means, which take advantage of the different densities of the two parts. The ores are then smelted and the impurities worked out by various methods of refining. In the case of aluminum, the ore must be carefully refined before smelting. In refining the bauxite, advantage is taken of the fact that alumina forms with soda a compound called sodium aluminate, which is soluble in water. The impurities, iron oxide and titanitic acid, are insoluble and silica is nearly so. The sodium aluminate is formed either by roasting the bauxite with carbonate of soda (known as soda ash), or by digesting with caustic soda in a closed vessel under pressure. In either case sodium aluminate is formed and is separated from the impurities by filtration and by washing the residue with hot water. The sodium-aluminate solution is decomposed by two methods, the alumina being thrown out of solution as a hydrate. In the Bayer process the solution is decomposed by agitation in the presence of some freshly precipitated hydrate. The spent liquor is drawn off and is used to take up a fresh quantity of alumina. Another method of decomposition employs the injection of carbonic acid, which forms carbonate of soda and aluminum hydrate. This hydrate then is carefully washed to free it from soda salts.

When apparently dry the aluminum hydrate contains 34 per cent of water chemically combined which must be removed before the ore is ready for reduction. The hydrate is therefore placed in furnaces where it is subjected for 48 hours to a heat gradually increased to 2,000 deg. F. The removal of the water from the hydrate leaves it alumina, as it comes from the furnaces. This looks like a white powder. Now is the point in the process in which the electric current is utilized in the Hall process of reduction. The reduction plants are located at points where waterpower is available in large quantities. The heat and electrolytic actions of the electric current reduce the oxide to pure aluminum, the reduced metal collecting at the bottom of the reduction pot and being tapped off and cast into ingots.

Physical Properties of the Metal

The fundamental advantage of aluminum is quite naturally that of lightness. The specific gravity of pure aluminum when cast is 2.59; when rolled, 2.68. The specific gravity of iron is about 7.21; that of steel somewhat higher. Thus it will be seen the weight of aluminum is, for equal

volumes, but slightly more than one-third that of iron. The coefficient of expansion of aluminum is 0.000022 per deg. C. (Richards); that of iron is 0.0000119 per deg. C. (Roberts-Austin). The melting temperature of pure aluminum is 659 deg. C. or 1,218 deg. F. The specific heat of aluminum is 0.22. Its thermal conductivity based on the conductivity of pure silver as unity is 0.313. Of the baser metals copper with 0.5 is the only one that exceeds it in thermal conductivity. The conductivity of iron is 0.11 or only one-third that of aluminum. It has recently been discovered that the thermal conductivity of aluminum increases with its temperature, and at a temperature of 700 deg. F. is practically three times the conductivity at ordinary temperature. The electrical conductivity of aluminum is 60.5 per cent that of copper for equal volumes, and since copper is three times as heavy, its conductivity is higher, weight for weight. Aluminum is preceded by gold only in malleability, preceding in this respect silver, copper, tin and platinum. It ranks sixth in ductility. The tensile strength of approximately pure aluminum is about 15,000 lbs. per sq. in. Therefore, as far as strength is concerned, it is seen that even in the unalloyed state, weight for weight, it will compare favorably with fair grades of cast steel.

It was early discovered that aluminum unalloyed was too soft, and that structures cast in it lacked rigidity. A number of alloys have been developed that have corrected the inherent limitation of the pure metal, at the same time sacrificing only to a limited degree its fundamental advantage of lightness.

The most widely used alloying metals are copper and zinc. Copper and aluminum alloy particularly well with high or low content of either metal. The aluminum bronzes with high copper content have been found to be equal, if not superior, to any other bronze so far developed. The copper-aluminum alloy most commonly used has a tensile strength of about 20,000 lbs per sq. in. Zinc alloys have been developed having greater strength, but at the present time probably 95 per cent of all automobile and aviation engine castings are made of copper-aluminum alloy.

Casting of Aluminum

The production of aluminum castings is a science in itself, and present-day success is built on many early failures. It is a long cry from the first attempts at castings to the complicated work turned out today. The mere possession of the formulas of suitable alloys by the foundry is not all that is required. Haphazard methods in the foundry are not conducive to the production of sound castings. In the early days "hit or miss" methods in the metal room in the preparation of the "charge" resulted in a great variation in quality of castings. It was found necessary in the furnace room to control the temperature lest the metal be burned. Too high a temperature destroys the natural vitality of the metal, and castings made from this burned metal are brittle.

Insofar as strength is concerned, probably no one factor is of more vital importance than the pouring temperature. The lower this is the stronger the casting. The casting

*Chief engineer Aluminum Castings Co. Extract of paper presented at Metropolitan Section meeting S. A. E.

that has barely escaped being a "mis-run" in the thinnest section, because of a low pouring temperature, is the best casting from all standpoints. The reason for this is found in the rapidity of crystallization. Naturally where the metal is poured cold, so to speak, the crystallization takes place quickly, and the crystals do not have time to arrange themselves in orderly manner, as they do if a longer time is granted. The production of successful castings requires careful attention to all the little details. In the foundries of the Aluminum Castings Co. technically trained men supervise every stage in the evolution of a casting, from the analysis of the virgin ingot to the delivery of the casting to the sand blast. Every foundry bay has a pyrometer, each casting being poured at the temperature an expert has determined to be the proper one, that is, just short of a mis-run. It is not too much to say that it is this technical oversight all along the line that makes it possible, to cite an actual case, to produce 125 crank cases, weighing about 100 lbs. apiece, in a day, and yet have an insignificant defective casting loss.

By far the larger number of aluminum engines are those in which the cylinders and crank cases are integral. This is an extremely rigid construction, and the aluminum makes a much lighter construction than the iron engines constructed after this design. Here again, the overhead-valve engine is the favored type, although occasionally an L-head is found. Both the Marmon and the new Premier engines have overhead valves. Except in rare cases the heads of all these integrally-cast cylinder and crank case engines are removable. From a structural and mechanical standpoint, the ideal way to make this engine may be with the head integral, but it multiplies many times the difficulties in the foundry. In the present stage of the art it is doubtful if this type of construction can ever be placed on a production basis. The foundry occasionally finds itself taxed to turn out individual castings with integral heads. The cores in the heads are extremely intricate and require the ingenuity of the best pattern makers and foundrymen to determine how to make and how to hold them properly.

Details of Sleeve Construction

The general practice has been to lay down a design similar to that dictated by past and current iron-cylinder practice, taking into account the modifications necessitated both by foundry and by mechanical requirements. The outside diameter of the cylinder barrels is made larger than would be the case with an iron engine, thus accommodating a cast iron or steel sleeve. These sleeves are either a drive fit and forced into place with a light press; or steam or hot water is run through the jacket space and the sleeve dropped into place. It is essential to get the sleeve into place at once, without loss of time, as otherwise it will heat and expand, sticking before it has been dropped home. This construction, in the main, differs from iron cylinder construction only in that the piston and piston rings operate against an iron sleeve. In the overhead-valve construction this sleeve is flanged at the upper end, fitting in a corresponding recess. In the integral-head jobs, of course, it is necessary to put the sleeve in from the bottom.

When the cylinder blocks are not cast integrally with the crank case, the bottom of the sleeve is machined flush with the bottom of the casting, and is supported, although such support is not at all necessary on the top of the crank case, the cylinder opening being somewhat smaller

than the outside diameter of the sleeve. When the cylinder head and crank case are integral, the sleeve can be flanged at the bottom and held by one or two machine screws. Another method is simply to upset the aluminum about the bottom of the sleeve.

Status of Aluminum Pistons

A discussion of the use of aluminum in modern motor car construction would not be complete unless mention were made of the Lynite piston. The aluminum piston has come and has come to stay. Any trouble existing has been in the nature of "growing pains." We have learned in the past year that it is not wise to attempt to carry weight saving to the limit. In other words, we should all be fully satisfied in cutting the weight of an iron piston in half instead of following the exact design of the latter in order to avail ourselves of the two-thirds saving in weight. The metal thus added will have beneficial effects if employed in increasing the length and the wall thickness of the piston. I have always advocated a long piston with a reasonably thick skirt. In a paper given before the Detroit section of the society last winter I advocated a length equal to one and one-third the piston diameter. The long piston with a fairly heavy skirt will take care of piston slap and should help materially in preventing oil pumping. On account of limitations that cannot be removed, occasionally it may not be found advisable to substitute aluminum pistons for iron ones in an engine already built. The piston unquestionably is the heart of the engine, which should largely be built around the piston.

Bodies of Cast Aluminum

The advantages are many in constructing the body with cast aluminum members. When the various sections are carefully proportioned the extreme bracing required in sheet metal body structures is unnecessary. In the elimination of some of these braces, sufficient weight can be saved to make the body built in the manner suggested as light, if not lighter, for equal strength, than the more commonly employed construction. It is certain that the body built up of cast aluminum sections is more rigid and sturdier than any sheet metal body can possibly be. The possibility of body squeaks is eliminated; warping and buckling cannot occur; and the body will outlast the engine. It will stand punishment that would be absolutely destructive of the ordinary sheet metal body, and after such punishment, more often than not, can be put back into as good condition as it was when new. A careful analysis of costs based on a normal metal market shows that this type of construction is not nearly as much more expensive than the prevailing one as would be expected.

Small Automobile Castings

Innumerable covers—transmission case covers, gear box covers and hand hold plates are usually made of aluminum. In most cases the clutch cone is an aluminum casting faced with suitable brake lining. Steering wheel spiders are almost invariably aluminum. Not infrequently aluminum footboards are used. Aluminum bearing caps have proved eminently satisfactory. Aluminum carbureters are practically always used on aviation engines. Pump housings as a rule are built of aluminum castings. Aluminum fans are used on many cars. In a number of cases the radiator tanks are aluminum castings. The radiator frames themselves are often aluminum castings. The hun-

dred and one of the smaller brackets around a car have been cast in aluminum.

The use of the aluminum brakeshoe is another step in the direction of unsprung weight reduction. Aluminum brake shoes, lined with suitable brake material, have rendered eminently satisfactory service, when and wherever tried. Aluminum brake shoes have not had much vogue in America, but in Europe both the Panhard-Levassor and the Peugeot companies use Cothias permanent mold aluminum brake shoes on all their models, both touring cars and trucks. Ordinarily, brake shoes of conventional design lend themselves extremely well to production by the Cothias process. We have produced Lynite permanent mold brake shoes, in some cases imbedding in the casting a steel slug to take the action of the expansion cam. Unquestionably future development in car construction will be in the direction of refinement of details, and I am certain that the aluminum brake shoe will be heard from in the next three or four years.

Machine Qualities of Aluminum

Casting for casting, aluminum can be machined nearly twice as fast as cast iron, resulting in a corresponding reduction in costs. Fewer men, consequently smaller floor space, are demanded when the shop is laid out to machine aluminum, than would be the case with cast iron. Considering the ease with which an aluminum casting can be handled in the machine shop, from the unloading platform to the assembly floor, to say nothing of the rapidity with which the casting can be put through one machine after another, comparative costs will show aluminum, even with the abnormal conditions prevailing with an increased initial cost for castings as a consequence, to be quite competitive with cast iron. When the market is normal, considering initial costs, casting for casting, it will be found that it is cheaper to use aluminum than iron.

Some time ago a certain manufacturer whose crank cases were machined outside his own plant considered the use of an iron crank case in the belief that he might reduce his costs. It happened that the manufacturer was, and will be for some time to come, dependent on one shop for the machining of his cylinders and crank case castings. The managers of this outside shop refused pointblank even to consider machining iron cases, stating that the trouble they were having with the one iron casting was quite sufficient.

Advice to Engineers

An engineer should bear in mind when designing a structure to be cast in aluminum the wisdom of consulting with the pattern maker and the foundryman. Make the keynote the elimination as far as possible of complicated coring. When it is necessary, bend every effort so to design the job that as much of the coring as possible can be green sand work. Design as far as possible all sections with uniform thickness. In crank case design do not try to decrease the thickness of the walls below 3/16 in. A thickness of 7/32 in. is better. The number of sound castings will increase appreciably if the foundry is granted this additional metal, and paradoxical as it may seem, the heavier casting can cost less because of the reduction in the defective casting loss. Design cases so that the ribs, brackets and bosses have plenty of taper. Further, have such parts join the main casting with liberal fillets. It is imperative that when a fairly light section runs into a heavy one large fillets be employed. As far as possible, do not use loose pieces on the pattern for

bosses. In most cases the green sand is not sufficiently strong and it is necessary to use dry sand cores, thus increasing the expense of the work. As far as possible, crank case interiors should be so designed that the ribs are far enough apart to do away with sharp sand projections, which complicates the making of cores.

Aluminum has an extremely promising future. When it is recalled that the output has increased from 283 lbs. in 1886 to 136,400,000 lbs. in 1914, the tremendous strides that have been made will be appreciated. Aluminum has been really known only for 30 years; iron has been known for a matter of 30 centuries, more or less; its heat treatment is but a development of the past few years. If this is borne in mind, we can easily believe that aluminum will, before many years have passed, be used in places where today the suggestion of its employment would be ridiculed.

Details of Trailer Manufacturers' First Meeting

Brief mention was made in the October issue of *The Hub* of a meeting of trailer manufacturers for the purpose of effecting a permanent organization, which was held in the Statler Hotel, Detroit, Mich., October 10. The preliminary meeting was presided over by C. W. Shipley, president of Sechler & Co., Cincinnati, and the regularly organized meeting by A. A. Keesler, president of the Watson Wagon Co., Canastota, N. Y.

After a full discussion of the question effecting a permanent organization, it was the opinion of those present that such organization should be effected, and immediate action in this direction was taken with the result that "The Trailer Manufacturers' Association of America" was unanimously adopted as a suitable name for the organization. The officers elected were:

President—C. A. Geiger, president of The Troy Wagon Works Co., Troy, O.

Vice-president—Miss Kate Gleason, secretary of The Rochester Trailer Co., Rochester, N. Y.

Vice-president—A. P. Warner, of The Warner Mfg. Co., Beloit, Wis.

Secretary-treasurer—J. C. Endebrock, secretary of The Sechler Co., Cincinnati, O.

The executive committee to be composed of the four officers of the organization and three additional members in the persons of S. A. Griggs, of The Detroit Trailer Co., Detroit, Mich.; A. A. Keesler, president of The Watson Wagon Co., Canastota, N. Y., and James E. Britton, of Rogers Bros. Co., Albion, Pa.

There were open discussions of a number of questions very important to the trailer industry. The first one was on the matter of publicity and education, which is really the keynote of the organization.

It was the concensus of opinion that what the trailer industry needs most right now is a wide campaign of publicity and education in the principles and advantages of trail-hauling.

Those present were favored with a talk by Geo. B. Russel, of the Russel Motor Axle Co., of Detroit, who, on account of his direct connection with the Internal Gear Drive Association and its publicity and educational campaign pertaining to internal gear drive axles, was well qualified to speak on the subject under discussion. Mr. Russel stated that the campaign inaugurated and carried on by the Internal Gear Drive Association resulted in

very excellent results and contributed not a little toward the great success which the internal gear drive axle has met with in the past two years. Mr. Russel outlined somewhat the plan under which their campaign was conducted.

It was decided that the association enter on a general campaign of publicity and education along the lines discussed and that the question as to the amount necessary to put into effect such campaign and the methods by which the amount should be raised, be left to the executive committee.

The matter of shows and exhibits was also canvassed. The question as to whether demonstrations were necessary in the making of sales was also briefly dealt with, the sentiment generally being against demonstrations. There was also a comparison of sales policies and methods by which trailers are being introduced.

Recognizing the desirability of having trailers properly classified and listed in railroad classifications, a freight committee was appointed, consisting of the following members: J. W. Menhall, Warner Mfg. Co., Beloit, Wis., for central classification; W. F. Jolly, Miami Trailer Co., Troy, O., for southern classification; J. N. Patterson, Los Angeles (Cal.) Trailer Co., for western classification; C. A. Geiger, The Troy (O.) Wagon Works Co., for eastern classification.

The time was very interestingly consumed in the various discussions and nothing was accomplished beyond organizing. There will shortly be a meeting of the executive committee, at which definite plan of action regarding the interests of the trailer manufacturers at large will be outlined.

"It was a most enthusiastic meeting," says Secretary J. C. Endebrock, "and was the best evidence that we have had up to the present time that the trailer industry has arrived. The meeting was very well attended and the amount of enthusiasm displayed and backed up by actual business done, augurs well for the trailer industry. The meeting would hardly have been possible 12 months ago. Trailer manufacturers for the most part at that time had very little behind them in the way of actual sales made. It is different now and a sufficient number of trailers have been sold and are in use to indicate more clearly than ever a very big field."

Companies represented at the meeting and their representatives were as follows: Detroit Trailer Co., Detroit, O. E. Bryon and S. A. Griggs; Fox Trailer Co., Windsor, Ont., Mr. Fox; Service Auto Trailer Co., Detroit, R. E. Leppo; Rochester Trailer Co., Rochester, N. Y., Miss K. Gleason and Mr. Elliott; Warner Mfg. Co., Beloit, Wis., J. W. Menhall; Rogers Bros. Co., Albion, Pa., R. C. Steers and Jas. E. Britton; Los Angeles Trailer Co., Los Angeles, J. N. Patterson; Martin Rocking Fifth Wheel Co., Springfield, Mass., C. H. Martin; Jahns Semi Trailer Co., Detroit, Messrs. Jahn and Kring; Troy Wagon Works Co., Troy, O., R. C. Sykes and A. R. Miller; The Sechler Co., Cincinnati, C. W. Shipley and J. C. Endebrock; Watson Wagon Co., Canastota, N. Y., A. A. Keesler; Miami Trailer Co., Troy, O., W. F. Jolley; Ohio Trailer Co., Cleveland, W. E. Ferris.

Death of Michael Higgins

Michael Higgins, founder and president of the Higgins Spring & Axle Co., Racine, Wis., died recently at the age of 61 years, after being a sufferer from throat trouble for more than a year. He was born in Oswego, N. Y.

Chile's Purchases of Foreign Motor Cars

The growth of the automobile business in Chile has been remarkable in that it has not been hampered apparently by the nonimprovement of the roads. This is shown by comparing the totals for 1908, 1909, and 1910, which were \$14,054, 11,760, and \$26,971, respectively, with the totals for 1913 and 1915, which were \$494,355 and \$302,813. The following table shows these latter figures in detail:

Imported From	1913	1915
United States	\$44,169	\$202,498
Argentina	84,608	25,290
Belgium	21,150	2,971
France	114,804	26,201
Germany	115,212	2,721
Great Britain	67,213	24,823
Italy	46,687	16,649
Peru	512
Spain	1,660
Total	\$494,355	\$302,813

At present there are about 1,300 cars in Santiago, between 300 and 400 of them being used as taxicabs.

As there are very few trips that can be taken outside the city, the most popular cars for private use are gasoline broughams, limousines, and landaulets, although it can not be said that any single type or style predominates. Black and dark blue cars should be sent only on special order. The underslung type is rarely seen, as it is not practicable on Chilean roads and streets.

Two-seated runabouts are not common, and when seen generally have a small seat behind for the chauffeur. This is demanded by custom, for even though the owner of the car is driving he must always have the chauffeur with him in case of need, as it would never do for the owner to change a tire or to crank the machine himself. American runabouts with a third seat behind, which could be folded into the body when not in use, thus giving the car a smarter appearance, should find a market.

Another undeveloped field is in electrics. No electrics have been seen in Santiago. Their introduction would be hindered at first by the lack of proper repair mechanics and charging facilities.

There should also be a limited market for a smart, high-priced American car of the limousine type.

Trucks are not used to any extent in the central and southern part of the country and the low cost of hauling by oxcart and wagon would limit their introduction. In the nitrate fields, however, they have begun to be used with apparently good results. There, where fodder and mules must be imported and labor is expensive, the truck should be able to compete.

Growth of Worm Drive

The Packard Motor Car Co., Detroit, Mich., has issued a bulletin on Packard worm drive motor trucks, which gives a brief but interesting history of the development of the worm drive principle and its application and use on the Packard trucks. The bulletin states that in 1913 only 1 per cent of the motor trucks manufactured by recognized truck builders were worm drive types. All other forms of final drive made up 99 per cent of the total. In 1915, 58.6 per cent of all motor trucks manufactured were driven by worm shaft and wheel. All other types of final drive represented only 41.4 per cent of the total.

Single-Piece Cast Metal Wheels

Practical and Efficient Design—Light Weight—Great Durability—Features of the New Smith Wheel for Trucks

Wheeled vehicles on the highways and byways of the world have been familiar objects for centuries. Present day models are the development of the earlier types to a higher plane of efficiency. Necessarily, with the advent of self-propelled vehicles, there came a demand for a specially designed type of wheel. Wagon and carriage wheels did very well for a time, but the rapid advancement of the motor truck industry has brought the need for something distinctly and specifically designed to provide for the extraordinary strains and stresses of heavy truck usage. While the automobile buyer perhaps holds the opinion that there is nothing to know about wheels that is not already known, and therefore pays little or no attention to their design, it is nevertheless easily understood that there are at least two qualities more especially desirable, perhaps, than any others—strength sufficient to withstand the hardest sort of service and insure safety and endurance, with as light weight as is possible without a sacrifice of any of the strength.

It is said that lack of a suitable wood for the construction of such wheels lead the European makers to consider the advantages of metal construction, and both cost and endurance were factors that impelled experiment with solid types, hollow spokes, hollow spokes and rims, and hollow hub, spokes, and rims, cast in one piece or in sections, assembled by welding or riveting. Assembled wheels were defective in that rivets loosened or sheared in heavy service. Experiments, however, resulted in the improvement of the quality of the metal, and although the defects of assembled wheels were not entirely overcome, metal wheels were regarded the more enduring for trucks, though they cost more than wood. Such wheels were usually made of steel and possessed many advantages, as light weight, greater strength, freedom from expansion or contraction from moisture or drying, rigidity when subjected to greater stresses, greater conductance and radiation of heat that may be created by the friction of tires, and less wear on the tires.

Metal wheels have been made in America and some truck manufacturers have designed and finished castings especially made to fit their requirements. These wheels have proved so satisfactory that their use has been continued. The limited demand, however, and the expense involved in producing such wheels on a commercial scale, as well as the fact that they cost more than wood wheels and have been practically unknown to truck buyers is responsible for the reluctance of manufacturers to adopt them as standard equipment for their trucks.

Accompanying illustrations show the details of construction and design of the Smith wheel. This advanced type of cast metal wheel is the invention of Burns L. Smith, of the Smith Wheel, Inc., a corporation of Syracuse, N. Y., which is now producing a series of sizes

suited for use on all machines of 3,000 pounds load capacity or more. The company maintains that its wheels, which are now used on a considerable number of trucks, have every quality that is claimed for metal wheels by European manufacturers, that the wheels are lighter than wood, are decidedly cheaper, and they are guaranteed for the life of the trucks on which they are used.

Burns L. Smith, the inventor of the Smith wheel, is a member of the Smith family for years connected with some of the largest business enterprises in central New York state, including the Smith Premier Typewriter Co., L. C. Smith & Bro., the Smith Gun Co., and the Iliion Arms Co., all of which are known as successful, progres-



Smith metal wheel designed for front axles, ready for installation of the hub

sive enterprises. Mr. Smith was for a long time connected with the L. C. Smith & Bro., and early in 1915 assumed control of the Smith Wheel, Inc.

He has a thorough knowledge of mechanics and his experience covers a practical training as a manufacturer, and he is in every way fitted to conduct the affairs of the new company in a most efficient and progressive manner. While he was developing the practical construction of cast wheels, Mr. Smith studied innumerable designs and drawings of foreign built types, in this manner obtaining a knowledge of the results of such work in actual service. He also judged these by the cost and the advantages of the one against other types and so knew that the wheel he intended to produce would have to meet this measure of every business man.

The Smith wheel is not made of steel or cast iron, but is an alloy that is made to a formula that the company possesses exclusively, which is unknown to others and is

regarded as an extremely valuable industrial asset. The metal weighs about the same as cast steel or iron and the composition is such that when exposed to strong oxidizing influences it will show very slight oxidation in a long period of time. The metal is maintained to be as strong as steel, being tough and elastic, and while it cannot be tempered to have spring resiliency, it has such structure that it does not crystallize when subjected to vibratory stresses, so that it will break as will steel, from fatigue, when exposed to vibration for a greater or lesser period. Another quality is that it can be worked easily and to close dimensions with machine tools.

The Smith wheel is cast with the core built in the mold and in such a manner that all of the walls are uniform in thickness. The hub is formed with a series of 12 openings from the bore (in which the axle hub is fitted) with flat external sides. This hub is shown in the illustrations, with a series of holes to which the hub flanges are bolted, and these holes are formed in the casting. The spokes, 10 in the front wheels and 12 in the rear wheels, have the vertex of the arches between them well rounded instead of sharp, and from the wall of the hub opening and from the wall at either side of the hub are webs that reinforce the hub structure. These may be noted in the illustration. The walls of the spokes of front wheels increase in diameter, but not in thickness, close to the rim, and the walls of the rear wheels are widened with reference to the axes, until they are approximately the full width of the rims, having a decided flare until they are united with the rims. This affords a much stiffer construction and insures against vibratory stresses that might cause crystallization of smaller areas of metal.

The rim is hollow, and within it, between the two metal surfaces, are a series of supports, as will be noted in the

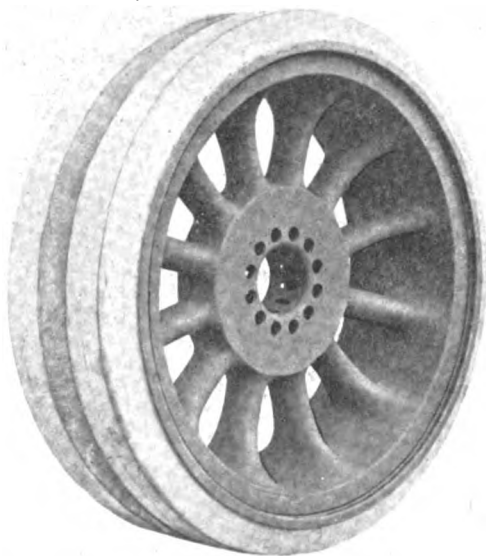

Smith metal wheel with dual tire adapted for service on trucks of large capacity

accompanying cut. Between the outer wall of the rim and the walls of the spokes is another series of supports in the form of crosses, with the arms that are transverse of the rim twice the length of those that extend circumferentially. The sectional illustration shows the substantial strength of each spoke due to the method of construction. Single spoke sections of these wheels are subjected to a test pressure of 30 tons, without showing the

slightest signs of distortion. As the load is always carried by six spokes, three upper and three lower, this fact gives some idea of the strength of the complete wheel. The Smith Wheel, Inc., has purchased additional machinery and is preparing for a large volume of business from truck manufacturers. The company's plans include the

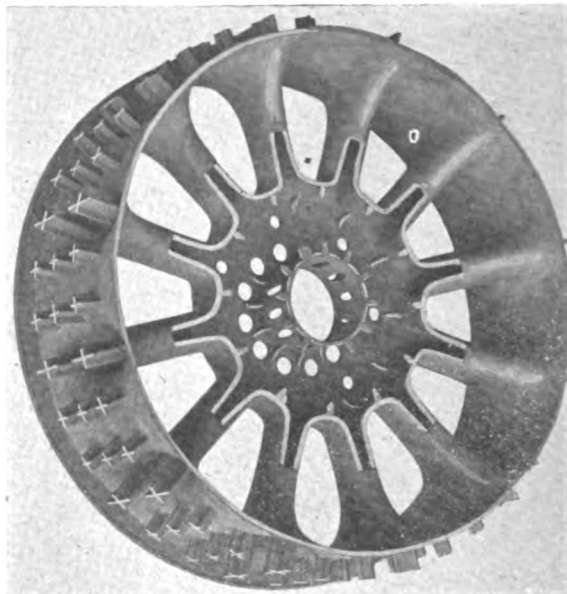

Smith rear wheels with outer rim and hub walls cut away to show the supports and webs that strengthen the metal casting

enlargement of its plant to whatever capacity may be necessary to meet the demand for Smith wheels. The low cost of the wheels and the many decided, practical advantages claimed for them by the makers should be large factors in the increasing popularity of this type of cast metal wheel, and in the growth of the company's business. Smith wheels are now in use on a number of American made trucks.

To Build Victor Automobiles Near Wilmington

The Victor Motor Co. has been formed with a capital of \$2,000,000, to take over the business of the Victor Car Co., of Philadelphia, and has bought 12 acres of land on the Delaware River at Grubb's Landing, north of Wilmington, to build a plant for the manufacture of moderate priced automobiles. This company expects to build about 5,000 cars a year.

The officers of the new company are C. P. Grandfield, president; C. V. Stahl, vice-president; H. H. Skerrett, treasurer; Regnault Johnson, secretary; and W. H. Bischoff, director.

Boston's Automobile Show

The fifteenth annual Boston automobile show, held under the auspices of the Boston Automobile Dealer's Association, Inc., and the Boston Commercial Motor Vehicle Association, Inc., will take place in Mechanics' Building, Boston, from March 3 to 10, inclusive. The exhibition, which is for pleasure cars, commercial vehicles, motorcycles and accessories, will be under the management of Chester I. Campbell, 5 Park square, Boston, Mass.

Steam Cars, Past and Present*

By Abner Doble

The Stanley steam car has been consistently manufactured since 1898 without cessation. The Stanley Bros. have maintained a production of about 600 cars a year, without paid advertising of any description, although they have very recently started a campaign. Their sales force has always been very meager, largely because people interested in steam cars simply went and bought them.

The evolution of their car has been gradual and conservative and Stanley cars have enjoyed a well merited reputation for service at low cost. They have used a fire-tube boiler and locomotive-type engine from the very first, and were not led astray by such faddish brain storms as single acting engines and red hot steam, which served to kill off such a large percentage of early builders. Improvements were added only when there was a well recognized demand from their customers. They have thus accumulated those necessities of modern motor cars, such as dynamo, electric lights, streamline bodies and one-man top, including a condenser, which they adapted to their car in 1914, and which allows about 200 miles' run on one filling. They now burn kerosene in the main burner (with gasoline for starting and for the pilot), and secure a very large mileage per gallon.

The fusible plug and its terrors were abandoned in favor of a thermostat for shutting off the fuel in case the driver ran short of water. Altogether the Stanley car has proved a very remarkable exception to regular automobile production.

Increased Water Mileage

One great disadvantage that steam cars labored under was insufficient mileage on the amount of water which could be conveniently carried. This was accompanied by the emission of good sized clouds of steam, and necessitated considerable searching at inopportune times for a further supply. Several steam cars were equipped with an apparatus intended to condense the steam, but a continuous run of a hundred miles without refilling was exceptional. Due to the use of heavy cylinder oil, these condensers as well as the water tank required periodical cleaning, which was an exceedingly distasteful job. Steam cars not so equipped would run approximately 30 to 35 miles on a tankful, about 35 to 40 gallons. In order to handle such large quantities of water, a steam syphon was used to fill the tank.

On making our preliminary investigations we found that no one apparently had considered using a honeycomb radiator, which would, in the same size, give approximately six times as much radiating surface. The reasons advanced against this use were that the thick oil was liable to clog the extremely small passages, and that the exhaust steam (particularly in cars with flash boilers) was liable to melt the solder. We also found a superstition to the effect that oil would injure the boiler and cause violent foaming. It was also believed that the successful lubrication of a steam engine required a heavy oil with a molasses-like behavior. It was particularly hard to reconcile these beliefs, and we determined that the best thing to do was to put a honeycomb radiator onto a car and operate it in conjunction with a fire-tube boiler. This we succeeded in doing late in 1913, and realized several startling results. The car would run anywhere from 1,000

to 1,500 miles on one supply of 24 gallons of water. The boiler in its operation was entirely oblivious to the fact that all of the oil used by the engine cylinder was pumped into it. Having established with absolute certainty that it was possible to travel an adequate distance on one supply of water, we turned to the study of the steam generator, with special regard to its operation when fed with water containing oil, graphite, and in winter, alcohol.

Defects of Flash Boiler

The so-called flash boiler, comprised of a series of coils forming, in effect, one continuous tube, was naturally out of it, as its entire absence of steaming stability was a source of constant aggravation to a driver in a hilly country. However, it had the immense advantage that the direction of the water flow was opposite to the flow of the gases of combustion, which placed the coolest water in position to take the last possible b.t.u. out of the flue gases. Its all steel construction with the consequent immunity from leaks due to low water was also a great advantage. These were worth having, so we marked them down on our specification of the perfect boiler.

The vertical fire-tube boiler was also out of the question for production, on account of its great weight, potential danger present with a large diameter shell, the high cost due to the apparent necessity for winding the shell with a mile of piano wire, liability to leak from oil working through the expanded joints where the tubes are fastened into the heads, and to overheating with low water. Notwithstanding these formidable disadvantages, it was the nicest boiler from the driver's standpoint when in good condition, due to its large reserve of water heated to the steam temperature, which admitted of a perfectly terrifying acceleration, and gave a feeling of absolutely unlimited power. It was also the most efficient boiler due to the regular close arrangement of the heating surface with extremely short distance through which the gases radiated their heat to the tubes. These advantages were therefore added to our specification.

The water-tube boiler, which has been built in almost every conceivable shape for motor vehicle service, had a black eye, and yet seemed to offer a basis on which the good characteristics of the flash and water level types of boilers might be combined. This at first seemed a very forlorn hope, as the maze of apparently conflicting conditions seemed unreconcilable.

Deposits of scale occurred in every type of boiler, with a resultant drop in efficiency and added liability of burning the already highly stressed heating surface.

In the water-level types of boilers, this scale would settle particularly in non-circulating portions of the boiler, such as the water column, and blow-off connections. This condition was the cause of most of the little bothers which beset the steam-car user.

In studying the apparently conflicting phases of this situation, we could see that every function was closely related to all others. That is, a water-level type of boiler held the temperature of the medium practically constant, with no possibility of temperatures high enough to effect a deleterious change in the lubricating oil. This allowed the continuous re-use of the oil. It also allowed the use of a soldered radiator to condense the exhaust steam. The honeycomb radiator condenses such a large portion of the exhaust steam that very little make-up water is required, with the result that much less scale is introduced into the system. Since very little medium is lost, espe-

*Paper read before Cleveland S. A. E.

cially in winter, alcohol can readily be used in large enough proportions to keep the car from freezing up. The use of a mixture of alcohol and water results in an imperceptible drop in power due to the large amount of heat carrying medium that must be circulated. By using regular gasoline engine cylinder oil for the lubrication of those parts in contact with the steam, we were able to make a steam generating and condensing system of this kind practical. First, it is more agreeable to handle and easier to procure than heavy steam oil. After it is introduced into the circulating medium, it rapidly goes into an emulsion with the water, due to the violent agitation and intimate contact. It cannot form clots and clog up the radiator passages, and since the return from the radiator is introduced into the bottom of the water tank, the agitation of the contents of the tank is sufficient to maintain the emulsion. This insures that the oil is regularly pumped into the boiler along with the water. The oil that thus finds its way into the boiler performs several valuable functions. First, it thoroughly coats every portion of the interior of the boiler with an exceedingly thin coating of oil. While this coating is extremely thin at ordinary temperatures, it is very much thinner at 485 deg. F., which is the approximate temperature of the boiler at 600 lbs. pressure.

Scale Cannot Stick

No scale will stick to a surface coated with oil, so that the interior of the boiler is absolutely protected from accumulations of scale as well as from rusting. Although there is very little scale bearing water introduced into the system due to the efficient condenser, in several years' operation, there would be an accumulation of the scale formed large enough to render a boiler useless, even though no scale adhered to the tubes. The second function of the oil in the water is to combat this condition, which it does with thoroughness and dispatch. As soon as a particle of scale material is thrown out of solution it is thoroughly coated with oil, which renders it incapable of sticking to any other particle of scale material. This scale, therefore, remains in suspension, and due to the violent ebullition and constant flow of the medium toward the steam outlet, is carried along and out with the steam, finally ending up in the water tank. This action appears to be exceedingly thorough, and in several years' use no accumulation of scale can be detected in any portion of the boiler.

The steam generator, which has been worked out to fulfill these interrelated conditions, is a flash generator in theory, and yet has the appearance of a water-tube boiler and carries a water level in the evaporating zone. The close regular heating surfaces duplicate the heat transference conditions of a water-tube boiler, and yet the progressive water flow, counter to the flow of the gases, with no circulatory flow, is true of the flash type. The water enters the bottom of the economizer zone, and flows to the top under the action of the pumps and gravity, which means that the hottest water collects at the top. From here the water overflows through a connecting pipe into the evaporating zone, where it is converted into steam. The water level is maintained about half way up the generator by means of an automatic by-pass valve, so arranged that when the regulator tube is filled with steam and consequently hot, the by-pass valve is closed by the expansion of this tube, forcing the water from the pumps to lift the check valve and enter the generator. As the water level rises, the regulator tube is filled with

water from an exposed pipe leading from the water manifold. This water is not in circulation in the generator, and, therefore, remains quite cool. The regulator tube contracts, opening the by-pass valve, allowing the water to return to the tank.

Perhaps the greatest disadvantage of steam cars was that known as "firing up," or getting the burner started to raise steam. After a fairly discouraging series of experiments, we discovered that kerosene could be ignited by an electric spark with absolute certainty and regularity if certain conditions were observed. These conditions were: First, the kerosene must be broken down mechanically so that the individual particles are sufficiently small to insure a rise in temperature past the point of ignition in the time element during which they absorb heat from the spark. Second, the spark must occur near the atomizing nozzle where the fog is dense enough, so that one group of kerosene particles igniting would invariably ignite the rest before being consumed. Third, the velocity must be sufficiently low so that the particles have time enough to absorb sufficient heat from the spark to pass the igniting temperature. Fourth, the mixture must be very much richer at the place where ignition is to occur than the best mixture for efficient combustion.

In connection with the mixing and igniting apparatus, it is necessary that the combustion shall occur in a refractory chamber so arranged that it attains a very high temperature. The intensely hot chamber gives an ideal thermal condition, and complete combustion of a large amount of fuel can be obtained in a very small space.

Thus, in the complete apparatus, we have an electric motor, direct connected to a multivane blower, and a graduated kerosene pump. The kerosene pump draws a measured quantity of fuel from the supply tank and forces it through the atomizing nozzle; the resultant fog is ignited by a spark plug. A measured amount of air is forced in by the multivane blower, which whirls this rich ignited mixture down through an inlet tube against the bottom of the refractory combustion chamber, where the fuel is consumed. To stop the combustion it is only necessary to break the blower-motor circuit. This is done automatically by means of a regulator set to operate at a pre-determined steam pressure.

Having thus reviewed the situation, and having described what specific mechanism has been designed (and tested) with a view to bringing the steam power plant as near perfection as possible, it might be well to consider what advantages may be rightly expected with a perfected steam power plant, and to compare the operation of the present-day gasoline car.

Steam Car Qualities

1. 100 per cent torque range, with maximum torque available at zero speed, thus making superfluous change gear mechanisms and clutch. The m.e.p. (and its equivalent d.b.p.) always under control of the operator, and variable by means of the throttle from zero to maximum, a maximum which is limited only by the tractive capacity of the driving wheels.
2. Utmost mechanical simplicity, with not over 25 moving parts in the entire car, and only 15 in the engine.
3. Perfectly smooth and quiet, due to very low engine speed with one to one ratio, and to location of engine on axle.
4. Low running cost due to use of kerosene or crude oil for fuel.

5. Low manufacturing cost due to simplicity—to lack of fussy work in production.

6. High thermal efficiency, which should be at least twice the efficiency of an internal combustion engine at ordinary driving speeds. As the maximum performance of automobiles is pushed higher, the greater will be the advantage of the steam plant under every-day operation.

7. Entire absence of lubrication troubles, since no contamination of the crank-case oil, by kerosene, gasoline, water, road dust, and carbon, can take place. The internal lubrication of cylinders, etc., is mostly accomplished by the water in the steam.

Motor Truck Club Considers Legislation

The first meeting of the season of the Motor Truck Club of America was held October 18 at the Automobile Club of America. The events of the evening were an illustrated talk by E. W. Stern, chief engineer of the Bureau of Highways of the Borough of Manhattan, and a general discussion of the truck legislation proposed for the state of New Jersey.

Mr. Stern described the motor trucks used by contractors for hauling broken rock excavated from the new subways from the Times Square district to the dump at West 54th street and North River. These trucks are of the semi-trailer type and carry six skips, each weighing from 2½ to 3 tons when loaded. Ten of them have been in operation 16 hours a day for almost a year, thus averaging about one trip an hour. They operate at speeds from 4 to 6 m.p.h. during the day and from 12 to 14 m.p.h. at night. About two-thirds of the load is carried on the steel-tired rear wheels, which are 41 in. diameter and 8½ in. wide.

As a result of the use of these heavy vehicles the granite block and asphalt pavement over which they have passed has deteriorated enormously. Mr. Stern stated that the amount of pavement repaired on these streets during the past year was over 60 times the amount repaired during the year previous to the operation of the trucks. The blocks and asphalt had fairly crumbled away and in some cases the concrete foundation of the street had failed.

As far as the engineering features of the proposed legislation are concerned, the club approved of limitation of a truck of 4,000 lbs. per wheel to a width of 96 in., so long as there was provision for special permits for other widths in special requirements. The club disagreed with the flat requirements that no metal tire be permitted to come in contact with the highway surface, unless the provision be made to apply to horse-drawn vehicles as well as motor-driven. The maximum height of a truck at 12 ft. 2 in. was agreed to be fair, so long as special permits are provided for emergency cases.

The provision that every truck have a sealed governor was not considered as reasonable, because it is impossible to keep governors sealed. It is desirable at times, when a truck is unloaded or to prevent an accident, that it be able to exceed its governed speed. The bill does not indicate which is to be limited, the speed of truck or of engine. It seemed to be the opinion that the provisions of the Massachusetts law, providing different speeds for different conditions and different pavements, are more reasonable than an arbitrary limit for all conditions alike.

There was no serious objection to the limitation of length of vehicles to 23 ft. 6 in., but it was decided to urge 28 ft. over all, with provision for special licenses for

unusual loads. No objection was offered to the requirement forbidding a center searchlight on trucks and regulating the height of headlamp rays. The club did seriously disagree with the requirement that trailers should be rubber tired, and many arguments were advanced to show that it is unjust and unnecessary, especially if horse trailers are to be permitted freely. In fact, it was pointed out that a trailer might be used alternately with motor truck and horse draft.

The requirement that every motor truck carry a spare wheel was considered too absurd to be defended, and the club frankly opposed it. The provision that tire width be measured on the rubber tire was assented to. Basing the license fee on width of tire was considered as unreasonable and inequitable, wrong in principle and not to be tolerated unless made to apply to all types of vehicles using the highways.

American Motors Adopts Eight-Hour Day

The eight-hour day has been put into effect at the Plainfield, N. J., plant of the American Motors Corporation, of which Louis Chevrolet is vice-president and chief engineer. The plant employs several hundred men, beginning operation November 1. In announcing the adoption of the eight-hour schedule, General Manager John C. Speirs stated that his experience as an employer of large bodies of men in the automobile, bicycle and other industries long ago convinced him that under modern high-speed conditions existing in the really efficient factory a man reaches his maximum of usefulness under the eight-hour day because he has daylight hours for recreation and rest and for family life and pleasures that keep him always at the top notch of efficiency. He looks on himself as a man and not as a mere drudge, an intelligent interested factor in the business, contributing to its success. He is proud of his job. In this way while humanitarian motives may not be the first consideration in adopting the eight-hour plan they are weighty and substantial in the matter of business results.

Coupled with the eight-hour day in the American Motors plant is the Speirs plan of paying on Tuesday instead of at the end of the week. This is done primarily to avoid errors, mistakes and inconvenience due to the rush incident to the end of the week and the short Saturday, but the plan is found to have a distinct advantage to the men as they administer their money to better advantage when paid in mid-week when the regularity of work serves to keep them reminded of their own and their family's real needs instead of the luxuries which a Saturday holiday suggests.

Got Contract for 100 Sleighs

William Bonell, of the Bonell Wagon Works, Eau Claire, Wis., some time ago was awarded the contract for the building of 100 sets of sleighs for the Jewel Tea Co., with headquarters in Milwaukee. The first shipment of 25 sets go to Butte, Mont. Shipments are to be made into five states as follows: One set to Oswego, N. Y.; one set to Watertown, N. Y.; six sets to Spokane, Wash.; one set to Wallace, Idaho; one set to Kellog, Idaho; two sets to Laurim, Mich.; one set to Geneva, N. Y.; one set to Gloversville, N. Y.; four sets to Syracuse, N. Y.; four sets to Elmira, N. Y. The remainder of the contract will be shipped subject to future orders by the Jewel Co.

Surplus of Maple First Time in Five Months

For the first time in five months there is a surplus of 2 in. maple offered in the hardwood market at St. Louis, Mo. Maple of 2 in. and thicker is used almost exclusively by automobile builders for frames on which to build the metal sides of the bodies. The maple is quoted at \$27 per 1,000 ft. at the mill, or at about \$35 at most of the automobile factories. There is considerable speculation among hardwood men as to why this accumulation while the automobile industry is forging ahead so rapidly. There are two explanations: First, the automobile builders are not buying far ahead because they are uncertain as to the steel deliveries; second, the rapid advance of maple last spring and a scarcity for a time persuaded the mills to cut more than is needed. The figures in the hands of the local sawmill men do not bear out the latter theory.

St. Louis a Center

A very large proportion of the maple used by the automobile industry is sold in St. Louis, which is one of the great hardwood markets of the country. It is the largest hardwood reshipping point, there being half a dozen large reshipping yards there and a dozen small ones. These yards buy hardwoods from small yards throughout this section and the south, and regrade the lumber in St. Louis, and then reship it. Most of the maple produced in this country comes from Missouri and Arkansas, and the Missouri cut is estimated at 4,000,000 ft. The Arkansas cut is smaller. Maple is only an incidental part of the output of mills, probably the largest output being that of the Gideon-Anderson mill at Gideon, Mo., with sales offices in St. Louis. The output of this mill is about 750,000 ft. a year, while the mill cuts more than 100,000 ft. daily of all hardwoods. From 250 to 500 ft. of lumber is required for an automobile.

Before the automobile industry came into being, maple was used chiefly by furniture makers and was then not cut more than 1½ in. thick and sold on a mill basis of about \$15 per 1,000 ft. At first ash was used for automobile body frames, but when it mounted to \$50 per 1,000 ft. a substitute was sought and was found in maple. In the four years since this use of maple began the price has advanced about \$9 per 1,000 ft.

Gum Widely Used

Last spring there was a pronounced scarcity of maple, says Automobile, and for a short time there was considerable bidding for it; but the builders of lower-priced machines turned to gum and relieved the pressure. Some of the gum used for automobiles is sold through St. Louis, but a greater portion is sold through Memphis. One-inch gum has for a long time been used by automobile builders for floors, etc. Yellow pine, which is sold chiefly through St. Louis and Kansas City, is used for crating.

Emerson Buys Plant and Materials for First Lot of 500 Cars

The Emerson Motors Co., of New York City, manufacturer of the Emerson four-cylinder car, has purchased a factory in Kingston, N. Y., where the car will be produced in quantities. The factory purchased is known as the Peckham plant. This factory when equipped will have capacity for 100 cars per day. There is a machine shop 424 x 70 ft., which is having an addition of 96 x 70 ft. built which is incorporated in the 424 x 70 dimensions. There is a main factory 487 x 224 ft., with a 2 in. plank

floor, which will be used for assembly purposes; and in addition are four warehouses with floor area of 70,000 sq. ft. The power house is 60 x 40 and the office building 50 ft. sq.

T. A. Campbell, president of the company, says that much machinery has been purchased and will be installed as soon as the floors are ready. The company also has a factory in Long Island City of 18,000 sq. ft., where the first 110 cars will be built.

The Emerson company early in October placed a contract for the manufacture of 500 motors with an outside concern, all to be delivered before January 8. Deliveries will be starting in the near future.

That the Emerson company is prepared to go forward with its first lot of 500 is proven by the orders placed for other car components and the quantity of these at present on hand. Over 100 frames are already on hand and the other 400 on the way to the factory. The 500 bodies are at present well under way and will all be delivered by December 20. Ninety axles are on hand and two carloads are in transit. All of the 500 will be delivered by December 21. There are 100 gearsets and 300 sets of lamps on hand. The same stocks of parts applies to many other minor components of the car.

The Emerson company has not yet signed with a single agent or allotted territory. There are applications on hand from several thousand agents, and allotment of territory will be started on December 15.

The finances of the company as of October 1 are shown by the audit report of the American Audit Co., of New York, which shows liquid assets at that date of approximately \$551,000. Cash on hand totaled \$307,447 and securities \$182,000.

Addition of Harrison Mfg. Co. to United Motors

The Harrison Mfg. Co., Lockport, N. Y., manufacturer of radiators, has been purchased by the United Motors Corporation. The purchase of the Harrison company brings the total United Motors Corporation purchases up to eight companies, these being: Hyatt, New Departure, Delco, Remy, Perlman, Klaxon, Brown-Lipe-Chapin, and Harrison.

The Harrison Mfg. Co. now becomes the Harrison Radiator Corporation, and plans have been perfected to increase its present capacity of 350 radiators daily to 3,000 per day. The corporation will make radiators for Chevrolet and other General Motors Co. subsidiaries.

The directors of the Harrison company have voted to keep the industry in Lockport and have secured options on all property adjacent to the plant on which a three-story factory will be built at once, to cost \$300,000. Further additions will follow. The company will employ about 700 men when the new facilities are available. It now has nearly 300 on its payroll. The enlarged factory capacity will be ready by March, 1917.

Goodrich Expansion Planned

Plans have been prepared by the B. F. Goodrich Co., of Akron, O., for the erection of a new group of buildings as an addition to the present plant at a total cost of over \$500,000. One of the buildings will be six stories in height and will cost \$415,000, and two others of one story each, will cost \$44,000 and \$38,000, respectively.

Pleasing Design of Body for Ford Chassis

Many types of body design have been evolved for fitting to Ford motor car chassis, and it is interesting to note the model recently built by a firm of Australian coach builders, at Melbourne, Australia. The accompanying drawing illustrates a small stream line body, with new features, designed for a particular customer. The effect of altering the bottom line as shown is a pleasing break away from the regular Ford lines, which effect is heightened by certain alterations to the chassis, which include the following:

A Livingston angular radiator is fitted in place of the standard pattern; steering wheel is lowered to give clearance of 18 in. between top of chassis and under wheel; a new tank (square), fitted in body behind seat, and built up as high as possible; new brackets or corner plates are fitted in place of old ones, and made level with bottom of chassis. This is necessary, as the body is built below top of chassis between center of hind wheel and dash; also new fittings for front and hind mudguards, also headlights as required.

The body is made on the curve principle, the bottom of framing from just forward to dash to forward of hind wheel being built down level with bottom of chassis. This means that the bottom sides are got out in two pieces, 1½ in. thick, swept as to plan, and butted against dash. A block is fitted between dash and bottom platform to finish sweep on elevation. Sections A, B, C, D are framed the same as an ordinary scuttle, and bolted on to bottom sides. A rail joins these sections together down the center of boot, terminating at D. Three curved pieces are fitted from D to bottom side on rail. Sections B and D should be left far enough apart to give ample room for

lid of boot. Two rails then are fitted from A to D to give desired width of lid. The middle rail is then cut away, also center of section C. Elbow rail is bolted on to shut pillar and section A, the corner being made either with a bend corner or block. Under door the rocker is made to stand up 1 in. above chassis frame as the floor top of chassis rests on this, and gives 1¼ in. for lino or carpet. Seat is made level with top of chassis at back, and raised to 3 in. front to give desired fall. Scuttle is framed as ordinary, also the dash. A cross bar runs across and resting on top of chassis, is fastened to bottom sides at N. Three pieces are framed to section A, and cross bar at N, to which is fixed the seat back. The body can now be panelled up either in sections and riveted or welded. No beading is employed excepting around door. Panels are turned over on top and underneath bottom sides. A block can be fitted in center if a bucket seat is desired. Polished wood is fitted completely round top to form finish. A neat low hood and a small frameless screen are fitted, the whole making a very neat and comfortable runabout.

Madison Motors Acquires Anderson Buggy Plant

The Madison Motors Co., Anderson, Ind., has consummated a deal for the acquisition of the buggy and wagon plant of the Anderson Carriage Co. This plant will be known as the Madison plant No. 2, and is to be used for manufacturing and finishing bodies and tops, as well as final assembly. Plant No. 1, the old Rider-Lewis building, later occupied by the Nyberg company, will be used for chassis manufacturing and assembly only. The addition of the Anderson carriage plant gives the company additional floor space of about 175,000 sq. ft.

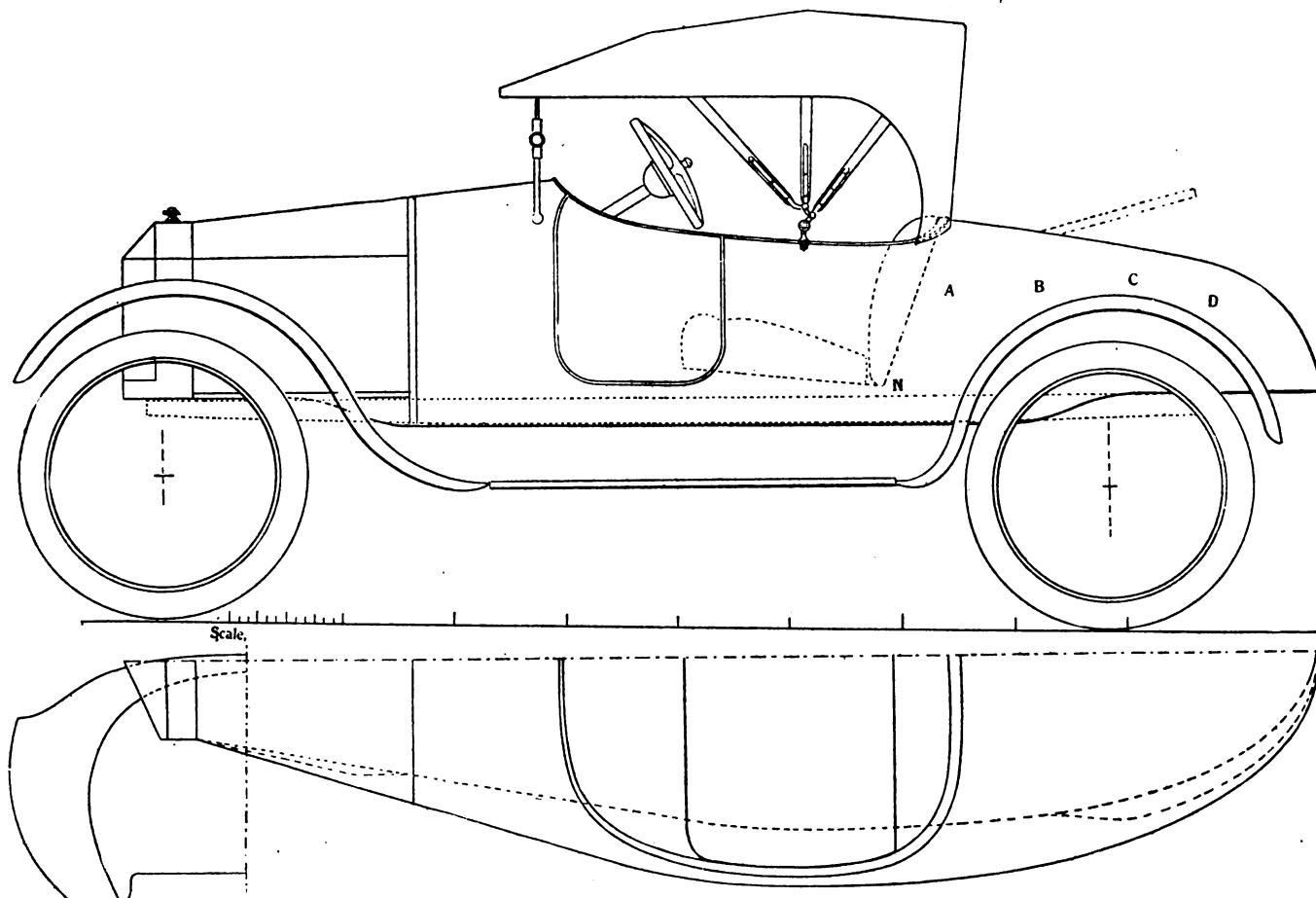

Time Payment Plan for Truck Sales

A time payment plan for truck sales has been adopted by the Guaranty Securities Corporation, New York City. About a year ago this company entered the field to finance the sale of passenger cars by dealers. The new plan is similar to the passenger car plan, but the percentage of cash demanded is not so great because the truck is a necessity and pays for itself. The Guaranty company, since January 1, has financed \$18,000,000 of passenger car business.

When the dealer sells a truck he collects 25 per cent cash from the customer and is paid nearly all the balance by the Guaranty corporation, which collects from the truck buyer through notes. For handling and for insurance a Guaranty charge is made and is paid by the truck buyer. A small part of the sales price of the truck is retained by the Guaranty corporation until the buyer's notes are paid, but on his deferred payment the dealer gets the prevailing rate of interest.

When a dealer sells a truck of which the f.o.b. factory list is \$1,200 the dealer adds freight and the Guaranty charge in arriving at the "buyer's delivered price." This buyer's delivered price is the basis of figuring.

Delivered Price to the truck buyer consists of the list price of the truck, including body and chassis, the freight from the factory to the dealer and the Guaranty charge. If the truck is an electric the delivered price may include the battery provided the Guaranty corporation approves of the make of battery. This, in effect, means that the battery may be included if it is supplied with the truck as shipped from the factory.

Guaranty Charges are approximately three per cent, but for convenience in figuring the prices of trucks have been graded in units of \$250 and a flat price arrived at for each class.

There are two charges, Charge A and Charge B. Charge A applies to all trucks below \$1,500 and Charge B must be applied to all above \$1,500. Charge B may be applied to those below \$1,500. Charge B is the addition of a flat \$30.50 to Charge A to cover collision insurance, and in case the service is such that collision is at all probable the dealer may insist upon the buyer paying Charge B where Charge A might otherwise prevail.

Above \$1,500 the Charge B is 5 per cent of the delivered price.

These two charges are made because the collision risk is considered greater on the heavier trucks. Rather than base the charge on weights it was deemed more satisfactory to base the dividing line on price, the corporation believing that \$1,500 is a good mark between heavy and lighter vehicles.

In case trucks are going into such a rush-and-hurry service as mail delivery, and if the price is below \$1,500, the collision risk is greater, and in that case Charge B would apply below \$1,500.

Charge A, as does Charge B, includes the usual fire and theft insurance and covers the cost of handling the deal. The insurance becomes effective as soon as the contract is signed and the truck delivered.

The dealer determines whether Charge A or B is to be made.

In case the dealer takes a car or truck in trade the allowance made must be included in the 25 per cent cash payment that he secures when the new truck is delivered.

The Guaranty corporation will not finance the sale of used trucks.

If a buyer wishes he may pay more than 25 per cent down and may make the term of payment less than one year—but not more. Dealers are encouraged to get as much down as possible and as short a payment term as possible.

After the dealer has secured the 25 per cent cash payment he enters into a conditional sale contract with the buyer.

Having the contract signed, the dealer forwards them to the Guaranty Securities Corporation and in a few days receives 90 per cent of the face of the note in cash. He then has 25 per cent of the whole and 90 per cent of the 75 per cent balance, which amounts to 92½ per cent of the whole price of the truck, including freight.

For the remaining 7½ per cent the dealer has to wait until the buyer makes the last payment, but this is represented by a deferred certificate, upon which he receives interest at the same rate the note itself carries.

The dealer has nothing whatever to do with making collections, and the buyer deals only with the securities corporation.

The buyer must fill out a purchaser's statement. Statement A is used in case the buyer is worth more than \$5,000 and Statement B if he is worth less.

Matters are still further simplified for the dealer by the attachment to the contracts, which are in duplicate, of a printed letter form. This is filled out by the dealer and mailed with the note and contract to the Guaranty corporation.

Advantages to the dealer are: He can extend his business without increasing his capital; secure sales where cash buying might stand in the way; get all his cost and nearly all his profit at the time of sale.

The buyer: Gets his truck at once and pays for it while he is using it; does not have to have credit handled through local bank; notes are held in trust, not hawked about.

Wagon Makers to Merge and Build Motor Vehicles

Steps have been taken by a number of wagon manufacturers of Cincinnati for the merging of their interests into a large concern for the manufacture of both horse-drawn and motor-driven wagons, to be used for all purposes. A preliminary meeting was held October 28, when the project was discussed and Attorney Emil Hauch was instructed to draw up the articles of corporation for a \$500,000 concern.

It is planned to erect a large central plant and use a number of the existing plants as branches. Some of the present plants will be abandoned entirely. Among those interested in the movement are Fred Dhonau, Jr., president of the F. Dhonau Son's Co.; L. J. Froelicher, of A. Froelicher Sons Co.; Michael Klopp, of Philip Klopp & Sons; George Finn, of the J. Finn Sons Co.; J. H. Lewis, H. Burdorf, and Harry W. Monning, individual manufacturers.

The fourteenth annual convention of the American Road Builders' Association, the seventh American Good Roads congress and the eighth annual national show of road building machines and material will take place at Mechanics' Hall, Boston, Mass., February 5-9, 1917.

Paint Shop

Points on Varnish

By. W. G. Scott

All of the oil varnishes are made on a basis of 100 pounds of gum, and the number of gallons of oil per 100 pounds of gum determines the grade or kind of varnish produced.

Polishing varnishes generally contain from four to eight gallons of oil, and are emphatically "short-oil" varnishes.

Rubbing varnishes usually contain six to twelve gallons of oil, although it is possible to rub a long-oil varnish, providing it dries quickly and is hard.

Architectural or interior varnishes contain anywhere from 16 to 32 gallons of oil.

Floor varnishes contain from 24 to 48 gallons of oil, and are generally made with China wood oil to render them scratch-proof and impervious to water.

Agricultural implement varnishes, which must be cheap as well as durable, contain from 32 to 48 gallons of wood oil with four to eight gallons of linseed or soya-been oil, per 100 pounds of rosin.

Railway carriage and automobile finishing varnishes are strictly "long-oil varnishes," and contain from 25 to 50 gallons of linseed per 100 pounds of kauri or other hard gum. Occasionally a small amount of wood oil is introduced to increase the hardness, and, in some of the cheaper grades, a certain amount of rosin replaces part of the hard gum.

The "short-oil" varnishes dry more rapidly than the "long-oil" varnishes, consequently less drying salts are required in the short-oil goods.

Litharge, red lead, manganese borate, black oxide of manganese and the resinates of manganese and lead are the drying salts used in varnishes.

The thinners are invariably turpentine and benzine, with occasionally a small amount of kerosene.

The agricultural implement varnishes seldom contain any other thinner than benzine, while the high grade carriage varnishes are thinned entirely with turpentine.

Medium grades of varnish are thinned with a mixture of turpentine and benzine, the price governing the quantity of benzine used.

Baking varnishes usually contain from 16 to 32 gallons of oil and must necessarily include some kerosene as a thinner. Kerosene in a baking varnish aids the "flow," permits of a higher baking temperature, and prevents brittleness.

Kerosene is also permissible in mixing and grinding varnishes where pigments are combined with the varnish, as the pigment takes up the small quantity of heavy hydrocarbon oil always present in the kerosene.

On the other hand, kerosene in the finishing varnishes is a positive detriment, as the varnish dries on top and remains soft underneath.

The presence of kerosene in a varnish is generally manifest by the presence of numerous small bubbles when being worked under the brush.

Whereas from four to six gallons of kerosene as a part

of the thinner might not do any harm, a large quantity would seriously interfere with the drying and hardening.

The durability of a varnish is nearly always determined by a "weather test," made by coating painted steel plates with the varnish, setting the plates at an angle of 45 deg., with a southern exposure, for 90 days or more. If the purchaser could know the exact amount of oil in the varnish, it would furnish some idea as to the durability. For instance, an agricultural implement varnish with 24 gallons of wood oil per 100 pounds of rosin cannot possibly be as durable as one containing 48 gallons of oil.

Whenever an alteration is made in a varnish to obtain a desired effect, some sacrifice must be made in other directions. Thus, if the oil be increased to the maximum to insure durability, some of the lustre will be sacrificed, therefore the purchaser must not expect impossibilities of the varnish maker.

In brief, the short-oil varnishes will possess great lustre and little durability, while the long-oil varnishes will have less lustre, but possess more durability.

Another important point in connection with varnish is the amount of thinner present. If the oil, especially wood oil, be cooked for any great length of time it will become so thick that an excessive amount of thinner will be required to reduce it to brush consistency, consequently a "false body" is produced and the varnish cannot be thinned to any extent without losing its lustre. A "true-body" varnish is one which will stand reduction with an equal volume of turpentine or benzine and still have a fair gloss.

To obtain the highest lustre possible with a long-oil varnish it is essential that the undercoat be perfectly dry and hard. A soft, oily undercoat will invariably absorb the oil in a varnish, causing it to "die away" or flat out.

Shellac varnish, unless very thin, is one of the worst foundations for varnish, as it possesses no "tooth," consequently when the varnish becomes hard it will chip or flake off, and is most easily marred.

A non-absorbent undercoat or a paint containing some varnish is preferable to an "all oil" paint as a foundation for varnish.

"Blending" is the term used to designate the mixture of different varnishes to produce one with certain desired properties. Thus, if two volumes of a varnish containing 40 gallons of oil per 100 pounds of gum, be mixed with one volume of varnish containing 10 gallons of oil, the "blend" will contain 30 gallons of oil per 100 pounds of gum.

Considerable experience is required in blending, as the varnish maker must know the characteristic properties of all the varnishes used.

"Blooming" of varnish may come from several different causes, viz., from moisture or a cold surface; from the presence of zinc resinate; and from the varnish being too new. Varnish, like wine, improves with age.

"Flattening" and "spotting" are due to applying the varnish on an absorbent paint; the presence of too much thinner; varnishing over a cold, damp surface; obnoxious

gases or impure air; and, in the case of wood oil varnishes, too low a temperature in cooking the wood oil.

"Skinning over" of wood oil varnishes in the can may be due to the use of raw rosin and under-cooked wood oil; too much drier for the oil present; and either too low or too high a temperature in the treatment of the varnish.

"Silking" is the term used to describe the silky appearance of a varnish which dries with minute parallel straight lines up and down. It is generally caused by insufficient cooking, where the gum is not properly combined with the oil; by the varnish "setting up" too quickly, as in the case of varnishes deficient in flow and levelling properties; and to an uneven drying of the material.

"Tears" are caused by air bubbles, and generally occur in varnishes containing kerosene.

"Sagging" is frequently due to fatty varnish, and occurs in varnishes containing an excess of driers and gum, also with varnishes not properly thinned.

"Yellowing," or the varnish showing brown on white striping, letters, etc., is due to an excess of benzine and gum, the color of the gum becoming manifest on the evaporation of the solvent.

To remove dirt specks from a freshly varnished surface, place a small piece of thick fatty varnish on the end of a sharp stick and touch the speck with the coated point. The dirt will adhere to the fat varnish on the stick and leave no mark behind.

Miscellaneous Pointers

"Wrinkling" of paint and varnish is due to an excess of drying oil with insufficient thinner. The fault may be corrected by adding more thinner, but part of the lustre and durability will be sacrificed by such treatment.

"Sweating" is the term used to describe the return of lustre or gloss on a painted or varnished surface which has been flatted by rubbing with pumice stone and water, or with pumice and oil. If the surface be rubbed too soon, i. e., before the paint or varnish is hard, it will "sweat back" or take on more or less lustre again. An excess of linseed oil in the paint or varnish will also frequently give the same result.

"Pin holes" in dried paint and varnish are the result of occluded gases or air in the liquids, and may come from briskly stirring the paint just previous to applying it, or may be produced by adding an excess of thin liquid drier. Continued brushing of the paint or varnish on a damp surface will also result in a pin-holed surface.

"Rubbing oil," occasionally used with rotten stone, and with pumice, in place of water, is nothing more or less than common paraffin oil. Occasionally it is thinned with a small quantity of benzine or kerosene, and in some cases crude petroleum is substituted for paraffin oil.

"Polishing oil" is made by mixing 15 parts of neutral oil with one part of kerosene, and a little of the mixture applied to a cloth moistened with water produces a beautiful polish on pianos, furniture etc., by rubbing briskly, then going over the surface with a soft, dry piece of cloth.

"Floor wax" is made by dissolving three pounds of ceresin and two pounds of carnauba wax in three gallons of warm turpentine. If preferred, the waxes may be melted together and the turpentine then added in a fine stream, stirring constantly. A water bath should be used, as an open fire is dangerous.

"Flexible paint" for canvas is made by dissolving 2½ pounds of rosin soap (in shavings) in 1½ gallons of hot

water, then mixing this soap solution with 3½ gallons, or more, of mixed oil paint.

Paint and varnish brushes are best cleaned with "paint and varnish remover," that containing acetone, benzole, alcohol, and paraffin wax being specified.

Place the brushes in the paint remover overnight, then rinse in benzine and wipe dry.

To keep brushes, place them in a brush-safe containing a slow drying finishing varnish. Benzine, benzole, turpentine, kerosene, and raw linseed oil are not suitable for the purpose. Water should never be used for bristle brushes, as it softens the glue setting, and also softens the bristles to such an extent that they become limp and flabby.

To remove white spots on a varnished surface, rub the spot several times with the following mixture: One part of raw linseed oil, one part of turpentine, one part of denatured alcohol. Mix thoroughly and keep in a tightly corked bottle.

Painting Iron and Steel

The fact discovered on the Continent that a single coat of paint resists the rust of the metal more than either two, three, or four coats, leads to the conclusion that it may be possible to not only economize in paint but to obtain better results by this less expensive method.

Although paints do not appear to possess much structure when viewed by the naked eye, the pigments of which they consist are revealed very definitely upon magnification. In some cases, says *Automobile and Carriage Builders' Journal*, the granules are exceptionally minute, uniform, and equally distributed. Frequently, however, they are either initially coarse, or coalesce into groups which practically become enlarged nodules. In many specimens the actual speck-like pigment is accompanied by semi-crystalline particles of apparently large dimensions either hard or soft, or a mixture of the two kinds, and upon these objects depends to a great extent the success or failure of the paint to be properly protective. The nature of the solvent is also important, and operates with much influence in regard to the pigment itself.

The writer covered glass slides thinly with even coats of various paints, and then sent reflected light up through them on the assumption that what is seen on the glass is the same formation as when it is over the metal, unless, indeed, the irregularities are increased, thus helping to understand what happens.

A wholly spirituous paint or varnish resolves itself into a gyrating mass of comparatively large globules, owing to the extreme mobility of the solvent. The granules are rolled over most remarkably, and arranged alternately into a central spot in each globule, and swished to the contours, where they meet others adjoining, and form large angular patterns. These movements keep up until the solvent has evaporated, and then the granules subside and coalesce into overlying flaky films. The point to note is that, as the globular collections of pigment granules are disposed of, they produce bold hexagonal designs with intervening clear spaces. Air and moisture can find their way underneath the flakes, and when the latter harden there remain little tunnels level with the plane of the metal.

The outer surface of the paint dries first, so that the resultant film thus formed tends to press down upon the softer under part and force it into available cavities, there-

by filling them with pigment and rendering them fairly impervious.

In actual practice the following happens: A moderately thin layer of paint is applied. It dries with open spaces around its larger granules; then there are tiny cellular cavities where free oil globules, or air, have been present, narrow under-grooves, and scattered particles of fairly large size. To all appearances it becomes hard, firm and intact, but really it is not so. Upon adding another coat to this first one, it is partly redissolved; the fresh substance soaks rapidly through the spaces of the first layer and resoftens the under parts. It also dissolves the soluble granules, and thus opens up for itself an extra number of passages. The second coat apparently dries, but, in reality, it has made an increased amount of porosity. Each additional coat must be supposed to produce the same effect until, finally, when we think there is a thick, firm, waterproof layer, it is really slenderly honeycombed from top to bottom with intercommunicating pores as invisible as those in an egg shell, and yet as free as the latter in admitting air and vapor. On the other hand, if a fairly thick single coat of paint is laid and undisturbed by too much brushing, the fine pigment granules and the larger particles sink to the bottom, and the solvent flows above them, and, during gradual oxidation, prevents the formation of the empty spaces.

South Enjoying Record Prosperity

"King Cotton has again ascended his throne and the south is enjoying the greatest period of prosperity in its history," declares A. Burwell, Jr., Chalmers distributor in Charlotte, N. C., who arrived in Detroit recently in an effort to boost shipments south of the Mason and Dixon line. He is brim full of enthusiasm over the business outlook for the next six months and is making plans on a broad scale to take full advantage of present record-breaking conditions in the cotton belt.

"The south is buying more and better motor cars than ever before," continues Mr. Burwell. "Since last May I have doubled my dealer organization and I expect to increase it another 100 per cent in the next six months.

"We have been face to face with the car shortage problem for the past 30 days and I made this rush trip to Detroit to try and secure more cars. Planters and farmers in the agricultural district of which Charlotte is the center, have more ready money this fall than they know what to do with. Many are purchasing their first motor cars, but a far larger number are trading in their cheap machines for automobiles of higher quality. We expect to hang up a record of sales in the next two months that will stand for some time.

"The reason for present prosperity is, of course, the high prices paid for the cotton crop. Cotton was bringing from 18 to 20 cents per pound when I left home, with prospects of reaching a new high level. Then, too, the planters in the recent lean years learned well the lesson of diversified farming. Practically every plantation in the south is now on a self-supporting basis, with healthy crops of wheat and corn and extensive herds of cattle.

"Not since the civil war has such a demand for cotton goods existed, and southern mill owners are waxing rich on the big shipments sent abroad. Practically all the mills are on an overtime schedule.

"Half of my territory has a deep sandy soil that provides the stiffest sort of test for an automobile. Around

Charlotte the country is extremely hilly and the cars with hill climbing ability sell most readily.

"With my entire dealer organization undergoing a process of expansion, I confidently expect to increase my 1916 sales by 200 per cent in the coming campaign."

Franklin Plans \$1,000,000 Enlargement

H. H. Franklin, president of the Franklin Automobile Co., Syracuse, N. Y., has just made public plans for the immediate enlargement of the company's plant to an extent involving the investment of \$1,000,000. Three extra floors, to cost \$500,000, with machinery installed, are to be added to a three-story reinforced concrete building at present under construction, the cost of which, fully equipped, also amounts to \$500,000.

This, the fifth factory addition within a year, will, when completed, add six acres of floor space to Franklin manufacturing facilities, and will bring the total area to 16 acres. During the 1915-1916 season, the Franklin factory has shown an expansion of 156 per cent, or an increase from 6½ acres to 16 acres of floor space, the largest building development in the company's history.

July 1, 1915, the capacity of the Franklin plant was 4,000 cars annually. With three of the five new additions now in use, the company is producing at the rate of 10,000 cars a year. The factory output will reach 15,000 cars a year when all the new facilities are in operation.

When the first three floors of the new building are ready for manufacturing purposes, the working force will be increased 17 per cent, and when the entire building is completed, the present number of workmen will be increased by 40 per cent.

Build Car of Pressed Steel

Ray Harroun, the well known racing driver and automobile engineer, who designed the Harroun car that is to be built by the Harroun Motors Corporation, a \$10,000,000 concern, says that the car of the future will be built almost solely of pressed steel, a type of construction which he has employed extensively in the new Harroun design.

This car, according to the designer, will contain a greater proportion of pressed steel than any car on the market. He also intimates that there will be important developments in pressed steel manufacture and that the products of dies and presses will largely displace such materials as gray iron, malleable castings, aluminum, wood, brass, bronze and a large proportion of the forgings now used.

"We have already solved the problems attendant on the manufacture of our frames, radiator shells, hoods, fenders, running boards, hub caps, rim carriers, crank cases, oil pans, instrument boards, clutches and clutch housings from pressed steel," Harroun declares.

"The Harroun bodies will be built of pressed steel panels. Our rear axle construction goes a good deal further than anything else in its line by utilizing pressed steel parts throughout its housing. All the brackets and supports throughout the car are of pressed steel. We have made wide use of pressed steel even in the motor."

Demountable Top for Buick

The Buick Motor Co. is equipping its touring cars with an all-weather top which is demountable. This body will be standard equipment and will cost \$212 extra in New York City.

Papers at S. A. E. Winter Meeting

The technical papers to be presented at the one-day (January 11) professional session of the winter meeting of the Society of Automobile Engineers will be truly representative of the enlarged activities of the society. Some of the papers will, of course, relate to automobile engineering, but in addition subjects of interest to aeroplane, tractor and marine engineers will be presented. The papers committee, of which K. W. Zimmerschied is chairman, is making the arrangements.

Captain Virginius E. Clark, U. S. A., will present a paper on aeroplanes with special relation to engines. This paper will deal also with the experiences of the army aviators on the Mexican border and suggest improvements in construction. It is also hoped that a detailed description will be given of a foreign aeroplane engine, which has recently been produced commercially in this country. A well known engineer will discuss the design of engines for farm tractors. A paper will probably be read on motor trucks, with reference particularly to the proposed military specifications now being considered by the truck standards division of the S. A. E. standards committee and a specially appointed board of the war department.

Tentative plans have been made to have experts contribute papers on pleasure car spring suspension, electrical equipment of gasoline cars, high speed automobile engines, dynamics of the automobile and crankshaft balancing. It will thus be seen that the papers are of sufficient variety to attract every member of the society. The authors will give brief digests of their papers, thus allowing for lengthy and adequate discussion of the more important ones.

A. O. Smith Co. Extensions

The A. O. Smith Co., Milwaukee, maker of pressed steel products and motor trucks, has increased its capital stock from \$1,000,000 to \$3,000,000, with an additional issue of 100,000 shares without par value, to accommodate the increase in its business, which has grown from a volume of \$500,000 in 1905 and \$2,000,000 in 1910, to more than \$7,000,000 in 1916.

Considerable new equipment is being installed in the main works at Twenty-seventh and Hopkins streets, and the old works at Park and Clinton streets, abandoned in 1909, will be transformed from a warehouse into a branch works to handle the overflow. The new equipment includes a 2,000-ton press, said to be the largest ever built, which does the work of four ordinary presses for producing steel frames for automobiles and motor trucks.

L. Raymond Smith, who succeeded his father, Arthur O. Smith, as president and general manager upon his death in 1912, continues to hold the chief interest and the active management of the business.

Nash Brings Out New Jeffery Sedan

The Nash Motors Co., Kenosha, Wis., has brought out two new Jeffery sedans in four and six-cylinder seven-passenger types, the tops being removable for summer touring. The large French plate windows drop 5 in. for ventilation in warm weather, the rear window measuring 19½ x 31 in. Divided front seats eliminate the necessity of fore doors and thus do away with the need for a panel between the front window and the rear door. Upholstery is gray whipcord and there are roll curtains on the windows.

Automobile Situation in Ceylon

On August 2, 1916, the Ceylon Legislative Council passed an ordinance imposing a duty of 33 1/3 per cent ad valorem on imports into Ceylon on motor vehicles, other than motor lorries (trucks) and other than vehicles which are imported under license given by or on behalf of the governor, for every 100 rupees of the value thereof, 33.33 rupees. The import duty on trucks remain at the old rate of 5½ per cent ad valorem.

Imports of motor cars into Ceylon for the 12 months ending May 31, 1916, with the countries of origin, were: United Kingdom, 61; France, 9; Italy, 2; United States, 270.

These figures are taken from the Ceylon monthly customs returns. There were 407, 459, and 273 cars imported into Ceylon in 1913, 1914, and 1915, respectively. It is estimated that there are over 3,000 cars in the island.

It is thought that the new duty will not affect the trade in low-priced cars so much as in the higher priced ones. However, the object of the new law is prohibition; hence, if imports continue in normal quantities it is probable that importation will be prohibited altogether. Dealers predict that the trade in motor lorries will be stimulated by the operation of the new law.

Until 1915 motor trucks were not listed separately from motor cars in the Ceylon customs returns. The figures show that 23 lorries were imported during that year, and it is estimated by local dealers that there are now about 100 trucks in the island. The usual retail price of a 3-ton truck is 10,000 rupees (\$3,245).

Monroe Co. Increases Capital and Elects Officers

The Monroe Motor Car Co., Pontiac, Mich., has increased its capital from \$250,000 to \$1,000,000. New officers were elected at a directors' meeting held October 24, and include R. F. Monroe, president and general manager; S. W. McFarland, secretary and treasurer, and S. S. Jenks, vice-president and manufacturing manager. The board of directors is composed of R. F. Monroe, S. W. McFarland, S. S. Jenks and W. C. Rowles, Pontiac; L. E. Haase, general sales manager, and R. T. Armstrong, of the Armstrong Mfg. Co., Flint, Mich.

The company plans to utilize the Port Huron plant for the construction of motors until some time in the future, when the plant will be moved to Pontiac.

The Monroe company, which opened its plant in August, 1914, making its first delivery January 1, 1915, has heretofore been selling its product through the Chevrolet company, of Flint. It will sell direct in the future. The company made 3,500 small roadsters in the past year and plans to turn out 7,000 cars during the coming year, which will include 2,000 small roadsters with roadster, clover-leaf or sedan bodies, and 5,000 four-cylinder touring cars with either touring or clover-leaf bodies. Its prices will be \$565 for its present roadsters, \$635 for the clover-leaf roadsters, \$965 for the sedan, and \$985 for the new touring cars with either touring or clover-leaf bodies.

Doehler Die-Casting Co. Extension

The Doehler Die-Casting Co. has contracted for a steel and concrete addition to its Brooklyn factory at Court and Ninth streets. The addition is to be 50 x 100 ft., seven floors high, at an approximate cost of \$150,000.

Determining Carbon in Steel by Combustion

By Jacob W. Barbey*

The working conditions in the chemical laboratory of one of the largest automobile companies required a large number of carbon determinations and the development of a very rapid and accurate method. The work had to be done by a single operator. It is possible to obtain accurate results, under the conditions outlined, at a speed of 10 determinations per hour. In the following, a brief outline of the chemical operation and a more detailed account of the mechanical features is given.

The well known rapid method of direct combustion of the steel and the absorption of carbon dioxide in potash was chosen. The carbon train consists of an oxygen tank, purifier, furnace, purifier and a potash bulb. The first purifying train is made up of, in order, a Johnson bulb filled with liquid potash, a mercury gage connected by a T tube, and third, a tower filled with calcium chloride. The furnace is an ordinary Hoskins tube furnace with a 30 in. quartz tube. Provision is made for advancing the tube as it becomes clogged with oxide. Following the tube is a U tube containing in order granulated zinc, calcium chloride and phosphorus pent-oxide introduced and separated by glass wool. The use of the chloride tends to lengthen the life of the phosphoric acid and save refilling.

The bulb used is an enlarged form of Geissler bulb, made

A table of operations and a thorough time study of all the individual units revealed a great loss of time and expenditure of effort in carrying the bulb to and from the balance and the samples to the boats. This was then absolutely eliminated by moving the balances close to the train, or vice-versa. A tube was led from the last dryer to the balance and directly to the bulb on the pan through the side door. Aside from the time and energy saved, the bulb temperature and surface moisture condition is never changed, is absolutely parallel by the counter balance and can be weighed absolutely accurately at once.

The following table of operations gives the average time required for each unit and the routine work to be done by the operator as ascertained by a test run on four different classes of steels:

Table of Operations: Conditions—Bulb weighed and oxygen gas running at required speeds

No.	Name	Unit	Time		Routine
			Sec.	Min. Sec.	
1	Connecting bulb..	17	0	17	
2	Withdrawing and inserting boat..	37	0	54	
3	Time to ignite....	40	1	34	Putting chips in boat for next determination.
4	Ignition	59	2	33	Figuring last determinations and adjusting weights for this one.
5	Sweeping out CO ₂ ..	120	4	33	Weighing out two samples (2 x 40 in.) Record Nos.
6	Disconnecting bulb	12	4	45	Determine the position of rider as closely as possible by sensitivity of balance before taking a full swing to verify.
7	Weighing	61	5	46	

From this table and the illustration the exact conditions can be realized. The fastest determination has been made in 5 minutes and 7 seconds. An average rate is 10 combustions per hour. The output on one single 8-hour day was 70 combustions in a running time of 7 hours and 9 minutes, the rest of the time being used for bulb filling and other work. Inasmuch as there are two three-minute rest periods every alternate two determinations, the operator has a total rest of 25 per cent and should not be overly fatigued. Routine checks average under one point with a maximum of one and one-half points of carbon, a control of 0.746 per cent on a 0.745 per cent Textor standard being not unusual.

Further study of the table may show where changes and improvements consistent with all other factors are possible.—Iron Age.

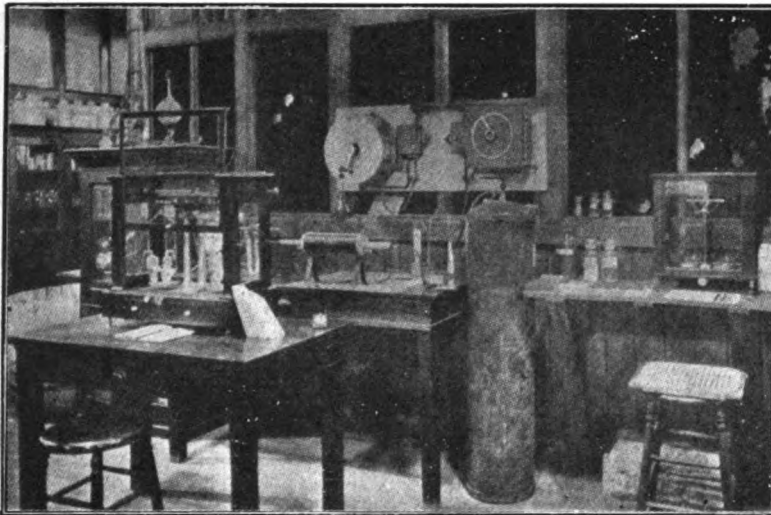

General arrangement of the apparatus in the laboratory of the Packard Motor Car Co. for rapid combustion of carbon in steel

to order. The bulb contains potash, Sp. Gr. 1.27. The first half of the drying tube contains broken stick KOH and the second half P₂O₅, introduced in small quantities by the use of glass wool.

The capacity of this bulb is 100 to 150 determinations and a weight increase of four to five grams. The bulb is connected and the oxygen passed at the rate of 340 c.c. per minute, indicated by gas meter at the end of the train, and the position of the mercury noted. At the end of five minutes the bulb is disconnected and weighed against another bulb similarly filled (a discarded one). The apparatus is then ready for use. During a series of combustions the oxygen is never turned off, saving the loss in time and annoyance of readjustment. A half-factor weigh, 1.3636 gram of sample, is used, laid on alundum contained in a platinum boat.

*Chemist, Packard Motor Car Co., Detroit, Mich.

National Motor Activities

The newly organized National Motor Car & Vehicle Corporation of New York will take over the National Motor Vehicle Co., Indianapolis, and will enlarge the plant in addition to a three-story reinforced concrete building 60 x 385 ft. now in course of erection. Property has been purchased for the other additions, the main building of which will be 140 x 328 ft. These improvements will increase the capacity of the plant to 6,000 cars a year. The new corporation at present is only a holding company for the entire capital stock, but it will eventually take over the company as a going concern. A. C. Newby, president; W. G. Wall, vice-president, and George H. Dickson, secretary-treasurer, all identified with the company since its establishment in 1900, will hold similar positions with the new corporation.

Sherwin-Williams Co. Celebrates With Golden Jubilee

The Sherwin-Williams Co. celebrated its fiftieth anniversary with a jubilee convention in Cleveland on November 13-14.

The Jubilee Chameleon, the convention daily, thus describes the opening day of the convention:

"Amid thunderous applause and waving of banners and handkerchiefs, President Cottingham opened the jubilee convention. Seated at the platform were Vice-president S. P. Fenn, Director E. M. Williams, and Secretary to the President F. E. Davis. To expedite matters, the roll was called by districts, each district manager responding for the number represented on the roster.

"For half an hour previous, as representatives and managers of The Sherwin-Williams Co. of the World filed into the auditorium, many interesting scenes, both amusing and impressive, were witnessed. Attired in auto dusters, caps and goggles, and each carrying a banner, the Kansas City Speed Boys made a dramatic entrance, led by Wayne Haverfield playing the district song on a cornet. Cincinnati division was given hearty applause for their comical "Cover the Earth" caps illuminated with Ever-Ready flashlights. Most districts had yells, cheers and songs, each trying to drown the noise of the others.

"President Cottingham's first words were to welcome the various units of our company—The Sherwin-Williams Company of the United States, The Detroit White Lead Works, which he referred to as our great allies, The Sherwin-Williams Company of Canada, The Canada Paint Co., and representatives of Lewis Berger & Sons, Ltd., both of London and Australia.

"Speaking of the absence of the late H. A. Sherwin, Mr. Cottingham said, 'The only cloud in our clear skies of rejoicing is the sorrow we all feel that the great founder of our business is not here to celebrate.' A gracious tribute was also paid to E. P. Williams and others who took so active a part in the inception of the business.

"Vice-president S. P. Fenn next welcomed the convention. He told of the inspiring influence of the men associated with the company from the earliest days, and gentleness and modesty of the founders. He said Mr. Sherwin regarded his co-workers as brothers, and idolized his home, and was a powerful factor in the community.

"Director E. M. Williams next followed, and spoke of the intangible and illusive spirit of the company and our responsibility toward the future.

"At the close of the prize distribution, Mr. Cottingham stated that he would like to have all present remain seated to listen to a brief word from the members of some of our affiliated companies.

"In the afternoon, G. A. Martin traced the historical development of The Sherwin-Williams Company, showing the increase in output, number of formulæ, etc. Together with H. J. Hain, he explained the manufacturing facilities of the company.

"R. H. Horsburgh outlined the new competition by divisions for the trade sales representatives. He explained that the district trade sales representatives competition, as formerly carried out, will be continued.

"In his closing remarks, Mr. Joyce outlined briefly the basis on which he decides upon the estimates for each representative. This is determined largely by their own ability, the conditions existing in their territories which may influence the results, and not—as some men have

seemed to think—upon the basis of their previous year's sales. Mr. Joyce heartily thanked the representatives for the loyal support they have given him during the past few years."

Cincinnati Carriage Makers' Club

The first meeting and dinner of the Carriage Makers' Club since the Carriage Builders' National Association convention was held at the Hotel Sinton, Cincinnati, on October 12, and was presided over by President Charles Fisher.

Charles Sawyer, a prominent attorney of Cincinnati, was the principal speaker of the evening. His subject was "The Personal Equation in Business."

Theodore Luth, the newly elected president of the C. B. N. A., made an address and thanked the members for their loyal support and hoped that all members of the Cincinnati Carriage Makers' Club would affiliate with the Carriage Builders' National Association during his term.

P. P. Hunter also urged the members to give Mr. Luth all the assistance they possibly can and further the interests of the C. B. N. A. Mr. Hunter said that the Cincinnati convention was one of the best in recent years.

Clarence Rennekamp, secretary of the club, spoke of the many favorable comments made concerning the work of the Cincinnati entertainment committee during the convention.

Mr. Hunter suggested that the Christmas dinner of the club be elaborated somewhat and that the ladies be invited. The idea was well received and will be taken up at the November meeting.

Edward Huling, of The Chicago Varnish Co., was elected to membership at the October meeting.

The question of "Standardization" was again taken up by the club. Talks along this line will no doubt come up from time to time until some definite action is taken.

Philadelphia Carriage and Wagon Builders' Association

The monthly meeting of the Carriage and Wagon Builders' Association of Philadelphia was held at the Hotel Hanover on Friday evening, October 20. Mr. Brodsky, an expert in the miscellaneous insurance field, was the speaker of the evening. He took for his subject "The Pennsylvania Workmen's Compensation Law," with which he is thoroughly familiar, and explained all its workings to the members. Following his address, Mr. Brodsky answered many questions.

Upon motion of A. P. Cardwell, of the Technical School committee, it was voted to again guarantee any deficit up to \$50, which may occur in conjunction with the drafting school at the Central Y. M. C. A.

During the week of November 13 the association conducted a series of benefit nights at the Walnut Street Theatre, the oldest house of amusement in the United States. The proceeds will be put into the hands of the entertainment committee for the purposes of the association.

Colfax Mfg. Co. Buys Top Co.

The Frederick W. Loomis Co., manufacturer of automobile tops, has been bought by the Colfax Mfg. Co., of South Bend, Ind.

Automobile Repair Business and Conditions Leading to Success

As a reader of trade papers devoted to blacksmithing, carriage building and painting, writes G. P. B., in *The Blacksmith and Wheelwright*, I was much amused at the plaint of a writer who claims to be familiar with conditions confronting the smith who takes up auto repairing. The writer stated that the smith who mixed up with the automobile business would find that he would either lose his old customers or would make a failure of auto repairing, and hinted that both might be the penalty.

There is no dodging the fact that some smiths will make a failure of auto work. Men fail in every line of business. The majority of failures are, in my opinion, due to conducting business as our forefathers did. It is surprising the number of smiths who look with disfavor upon what they term "new fangled contraptions." It is difficult to convince them that labor and time saving equipment is a good investment. Even when their trade goes to a progressive competitor the old timer will lament the lack of appreciation of the smith who learned his trade 25 years ago.

The automobile work was not sought by the blacksmith. It was thrust upon him. As one of your writers stated some time ago the smith (carriage builder) was depended upon by the automobile repairmen to do work long before any smith gave a thought to automobiles. The development has been gradual, it is true, but nevertheless it has been steady, and today there are hundreds of carriage shops that do thousands of dollars worth of automobile work each year.

Personally I do not know of a single case where the smith went into auto work completely at a single step. Very few are capable of taking up the work in all its branches and because of the knowledge any experience required to be successful, to compete with established automobile repair shops, the smith who are now conducting large shops developed gradually.

I know of two other carriage builders in my city who started this way and who are today doing a large volume of automobile work. By automobile work I mean aside from the overhauling of the chassis, the lengthening of chassis to take a special body, the building of all types of bodies for truck chassis, painting and lettering the same, as well as painting pleasure automobiles. And there is always opportunity to obtain one's share of municipal work, to say nothing of suburban work. On this subject I will speak later.

We were pushed into automobile work by our customers. At first we repaired springs, straightened out axles, attached fenders, ironed bodies for tops, installed tire holders, shock absorbers, fuel tanks, etc., work that was sent us by auto repair shops. The body work developed with the demand for commercial automobiles, and our trimming department did quite a business repairing tops. A little advertising in the newspapers on this line of work greatly increased our business and we expanded as it were by catering to the municipal authorities for special body work on motorized apparatus, police patrol, ambulance, fire and health department.

The work of repairing the automobile proper began in a small way when we purchased a second hand car and when one of our employes volunteered to keep it in order. He was a natural mechanic, had some knowledge

of automobiles, and was quick to learn. After he had helped out a few of our regular customers in locating trouble that developed while they were at the shop on general business, we decided to take up repairing in a small way. We were fortunate in hiring during the winter months an expert repairman, and setting off a portion of the carriage display room, started in. Many of our carriage customers owned pleasure cars and we did not have any trouble in keeping our man busy. He had a fine set of tools and by supplementing these with others from time to time we gradually obtained a practical tool equipment. By spring the work increased and we engaged another man, which made three, as the helper, under the tuition of the expert, was capable of any reasonable overhaul.

The increase in business was gradual but it grew in volume and the auto department became too small. A careful investigation of the possibilities and based on what had been accomplished led us to erect a one-story brick building and practically join it with the two-story carriage, blacksmith and paint shop, 50 x 40 ft. This afforded a repair shop of 40 ft. sq., as 10 ft. was taken for the office, also a space 10 ft. sq. for the oil, grease and fuel room which has a brick partition between it and the office proper. The building is on the corner, affording an opportunity to use two large display windows for showing accessories and supplies which are stocked. The fuel pump, a curb outfit, was installed. We did quite a business on fuel, having a sign stating the price. A push button rang a bell in the shop, summoning the boy when anyone desired gas. This saved the expense of keeping a man in the fuel room. Sundays the boy took charge of selling gasoline for a small amount. As we sold at the same price as the nearby garages, our profits at the end of the year on gas were considerable.

Entrance to the repair shop was by a door, and the partition has a large window so that we can see what is going on in the shop. A large cabinet is filled with catalogs, descriptive matter, etc., relating to accessories, equipment and supplies. Tires are carried in a rack easily seen through the windows from the street. The phone is located on the big desk and is attended to by the bookkeeper. Branch phones connect the repair shop, blacksmith, paint, woodworking and trimming departments. The layout of the repair shop included benches, pits, machinery, etc. There is a door leading from the shop and marked "To the elevator." This brick partition is against the side of the old shop, and the elevator to the second story or paint shop is opposite the door. This arrangement makes for convenience and saves time when a chassis or body is to be painted.

When the auto shop was completed and machinery installed, we installed a time recording system, one that kept a record of the arrival and departure of the employes as well as furnished an accurate record of the exact time spent on each piece of work. The clock is a standard affair, and the system includes a job card which is stamped by the workman when he starts a piece and when he leaves it. The system takes care of a workman leaving a job for another, then returning to the original. The system absolutely protects the house as well as the customer. It also relieves the foreman of the work of keeping track of the time, etc. Provision is made for computing the cost of each item as well as charging the stock used. An advantage of the clock referred to is that it

can be obtained with card systems that can be changed to meet different conditions.

The automobile department is maintained as a separate unit of our business; in fact, the system is such that it might be located in another state insofar as the expense of maintaining it is concerned. A certain sum is charged for interest on the cost of the building, on the tools and equipment, and a certain per cent for depreciation. Insurance and lighting are charged separately from the other building which supplies the heat. A certain amount is charged the automobile shop for the heat and credited the carriage shop.

If a workman of the auto shop spends any time on a carriage, for example, such as machining, etc., the time and stock is charged to the carriage shop. If any blacksmith, wood or trimming work is done on motor cars by these departments, a charge is made against the automobile department.

To keep track of the work and insure that each department will receive credit for work performed on automobiles we use a card system which is best explained by assuming that a car comes to the shop for repairs, painting, etc. The name and address of owner, number and model, and work to be done is made out on a slip, and the time the job is to be delivered is also entered. The bookkeeper makes out the repair card for auto shop, and as there is work for the blacksmith, woodworker, trimmer and painter, a separate slip is made for each. These consist of a manila tag bearing the job number and the four used are sketched herewith. The smith work calls for welding the frame (we use oxy-acetylene), repairing springs and setting demountable rims. The tag is in two parts, the upper being attached to the car while the lower is retained in the office. As soon as the chassis is ready for the smith it is sent to the blacksmith shop. The time, stock, helper, etc., is entered on the tag which is removed when the work is completed and sent in to the office. This varies from the usual method. Generally the smith and helper strips or gets the chassis ready. By having the automobile department do the work it is done much quicker and auto rates are charged. It does not cost the customer as much in the end.

The slip for the wood work is practically the same. Here it will be seen that the demountable rims were furnished by the customer. The bookkeeper, however, checks up this point by charging up the rims to the customer and crediting them when they are brought to the shop by him. There is also a slip for the trimming department and another for the paint shop. The latter does not give the time of labor as do the others. When the slips are returned to the office the labor and stock is computed and entered on the books.

By this system we are able to note at the end of three months or a year just what each department is doing, the gross business, expenses and profits. An overhead is charged to each department of the carriage shop, and as all automobile work is credited it, we know how much business is brought in by autos. In other words, by running both shops separately and charging up or dividing the common overhead expense, such as phone, bookkeeper, etc., we can at the end of any time know just where we stand. It is surprising the amount of work that is credited to the carriage shop in the course of a year. This is explained by the fact that we build and attach all types of truck and commercial bodies to chassis and install

bodies for a number of automobile agents. We also carry a number of bodies in stock, particularly for Fords. This brings up a point generally overlooked by the small shop and that is the opportunity of building up a trade on the light delivery type of bodies for Fords and other cars. It is a simple matter to obtain photographs, catalogs, specifications, etc., of ready made bodies, and with these on hand the requirements of a customer can be met. This will bring additional business to the smith, as the bodies must be installed, some iron work done, as well as painting and lettering.

The fact that we erected a building especially for auto work answers the question as to whether there is profit in the work and another question is, are automobile tools and repair equipment a good investment? I would not advise the small shop to invest too heavily, but to feel the way by taking on a certain line of the work and increasing it as conditions and experience warrant. Much of the equipment can be bought on easy terms, but the purchase of a lathe, sensitive drill, arbor press, etc., should be avoided until sufficient work is being done to warrant investing in these. It is a business proposition and should be handled as such. The future is what one makes it in auto repairing. It can be made successful by charging a reasonable price, by a one price to all, and by giving personal attention to all details. Keep in close touch with every branch of the business, know what each workman is doing and give every customer your personal attention. Always be accessible to a customer with a real or imaginary complaint. Insist on courtesy being shown the customers. It means hard work and long hours, but to succeed in these days one has to work hard and long. Judicious advertising in the papers helps. Never promise a delivery of a job unless you can do it. Keep abreast of the times by following the developments in the automobile industry and its allied trades. If you find a department not showing the proper returns find out why and correct the trouble.

Job No. 27	BLACKSMITH		Auto Work
	Weld Frame	Hours	Min.
	Repair Springs
	Demountable Rims
	Stock
	Helper
	(Sign) Workman

Job No. 27	Auto	Blacksmith
	Weld Frame.	
	Repair Springs.	
	Fit Demountable Rims (furnished by owner).	

Job No. 27	WOODWORKER		Auto Work
	Build Up Rims for Demountable.....	Hours	Min.
	(Rims supplied, see office).....
	One new Bow.....
	Stock
	(Sign) Workman

Job No. 27 **Auto** **Woodwork**
 One Set Demountable Rims.
 (Furnished by Owner).
 One new Bow.

Job No. 27 **Auto Work**

TRIMMING

	Hours	Min.
Repair Curtains		
Repair Top (New Bow).....		
Clean Top		
.....		
(Sign) Workman (Jones).....		
.....		

Job No. 27 **Auto Work** **Trimming**
 Repair Curtains.
 Repair Top (new Bow).
 Clean Top.

Job No. 27 **Auto Work**

PAINT SHOP

Paint Gear.
 French Gray.
 Fine Black Stripe.
 Touch Up and Varnish Body.
 Note—Paint fenders same color as gear.

Job No. 27 **Auto** **Paint Shop**
 Paint Gear and Fenders French Gray.
 Fine Black Stripe.
 Touch Up and Varnish Body.

Death of James F. Taylor

James F. Taylor, vice-president and treasurer of the American Oak Leather Co. and prominently identified with the business interests of Cincinnati, died suddenly Saturday evening, October 21. He had returned home only a few hours before from the Business Men's Club, where he had dined with a party of friends. While seated in his library he complained of a severe pain in the region of his heart and despite heroic treatment passed away a few minutes later.

Mr. Taylor was president of the Paint and Enamel Leather Manufacturers' Association and a member of the Carriage Builders' National Association.

He was born in Westport, Ky., October 17, 1850. After completing his education he became associated with the firm of Conrad, Fabel & Mooney, Louisville, Ky., manufacturers of leather. In 1886 he and several other men actively identified with his firm, went to Cincinnati and organized the American Oak Leather Co.

The decedent is survived by his widow and two sons, Benjamin P. and Frank L. Taylor.

Bankers Purchase Control of Hess-Bright

The Hess-Bright Mfg. Co., manufacturer of ball bearings in Philadelphia, Pa., announces the purchase of controlling interests in its company by a group of financial men who also own a substantial interest in the S. K. F. Ball Bearing Co., Hartford, Conn., including Frank A. Vanderlip, National City Bank, New York, and Phillip W. Henry, Thatcher M. Brown, and Franklyn B. Kirkbride,

of New York, and Marcus Wallenberg, of Stockholm, Sweden.

The Hess-Bright company and the S. K. F. company will be operated independently of each other. The manufacturing facilities of Hess-Bright will be materially increased. B. D. Gray, recently elected president, retains his former stock holdings and will continue to manage the business as president. F. E. Bright, one of the organizers of the company, has retired from active participation but remains as chairman of the board of directors. The remainder of the organization continues as heretofore, excepting the board of directors, which follows: Chairman of board, F. E. Bright; president, B. D. Gray; Willard Parker Butler, New York; Arthur V. Morton, Philadelphia; Paul von Gontard, managing director of the Deutsche Waffenund Munitions Fabriken, Berlin, Germany.

Complete control of the Conrad patents will continue with the Hess-Bright Mfg. Co. as heretofore.

New Company Takes Over Pierce-Arrow

The Pierce-Arrow Motor Car Co., Buffalo, N. Y., will be taken over by the Pierce-Arrow Motor Car Corporation, which has been formed with 100,000 shares of 8 per cent convertible preferred stock and 250,000 shares of common without par value. A syndicate of New York bankers, headed by J. & W. Seligan & Co., will underwrite the new issues. The new capital will be used to increase the factory facilities.

George K. Birge, now president of the company, and prominent in the wall paper business, will retire, and Col. Charles Clifton, now treasurer of the concern and for several years head of the N. A. C. C., will succeed him. Otherwise there will be no change in the organization.

Discher Patent Held Valid

The Discher patent covering bumper bracket construction has been held valid and infringed by the Auto Parts Mfg. Co., of Milwaukee, Wis., and a permanent injunction has been granted in favor of Grant F. Discher, president and general manager of the Gemco Mfg. Co., Milwaukee, which controls the patent. The patent, No. 1,052,224, relates to a bumper bracket having a lug, which bears against the front end of the automobile frame side member, and an adjustable clamp, using a transverse bolt passing through two vertical slots, one on each side of the frame member. John F. Harper has been appointed special master to determine damages.

The Auto Parts Mfg. Co. petitioned for an appeal to the U. S. circuit court of appeals for a temporary suspension of the injunction. The court granted the suspension on condition that the company file a bond for \$15,000 to cover any damages that might be sustained while the appeal was pending, should the higher court confirm the decree of the district court.

Ditzler Color Co. Increases Capital

At the annual meeting of the stockholders of the Ditzler Color Co., Detroit, held on September 6, it was decided to increase the capital stock to \$300,000, of which one-half is preferred and one-half common stock. The annual election resulted in the selection of the same officers as heretofore: T. W. Connor, president; E. R. Hoag, vice-president; K. W. Connor, secretary; R. Pulfer, treasurer.

United Motors Buys Houk Co.

The Houk Mfg. Co., maker of Houk wire wheels, Buffalo, N. Y., has been purchased by the United Motors Corporation, bringing the total number of concerns owned by this corporation up to nine. The Houk company will continue as a separate manufacturing organization, and George W. Houk, founder of the company, will continue as manager.

There are 500 men at present on the Houk payroll, but this number will be increased by 300 at once. Previous to November 1 the capacity was 1,000 wheels per day. It will be 4,500 per day by February 1, according to present plans.

Approximately \$1,000,000 will be expended on new buildings and equipment, the work to be started at once. The capacity of the plant will be doubled.

George W. Houk's work in this country started as a licensee of the Rudge-Whitworth company of England. He began manufacturing September 23, 1913, and first deliveries were made in February, 1914. Today the company has an account with 85 different car makers. It is manufacturing 40 per cent of the wire spokes used in its wheels. The spoke manufacture was started in March, 1915, when Houk purchased the American Spoke and Nipple Co., of Detroit, and moved the factory to Buffalo.

New Up-to-date Plant for Saxon

The Saxon Motor Car Corporation, Detroit, Mich., has begun the erection of a new plant on 40 acres of land recently purchased by them. The first unit will be 240 x 1,262 ft. and will have 500,000 sq. ft. of floor space, and will house several departments so grouped that a car will move steadily forward from one end of the building to the other for assembly construction.

Progressive manufacturing and assembling will be employed in every department possible. Incoming material will be moved by traveling cranes and elevators to the stock rooms, and a system of conveyors is planned by which stock will be carried to the different manufacturing departments. The first unit will be completed May 1, and the remainder of the buildings June 1, 1917.

Acme Producing New Truck Worm Axle

The Acme Motor Truck Co., Detroit, Mich., is now producing a worm-driven truck axle incorporating, as its principal features, the M. & S. worm differential. Another feature of the axle is that the brakes, of special design, have a full contact for the entire circumference excepting the small space occupied by the actuating cams.

It is built in a size for 2½ or 3-ton trucks, the standard reduction for this size being 7¾ to 1. The axle is a one-piece steel casting, with the worm gear carried in a separate carrier secured by eight bolts and having the small worm housing and axle bowl cover integral with it. The axle is of the semi-floating type, running on ball bearings throughout. The worm is of the straight type.

Templars Motors Corporation Formed

The Templars Motors Corporation, Cleveland, has been formed, and will manufacture a four-passenger roadster at \$1,250, a five-passenger touring car at \$1,250, a five-passenger sedan at \$1,850, and a two-passenger roadster at \$1,225.

Production Started on Princess Cars

The Princess Motor Car Co., of Detroit, Mich., has started production at the rate of about ten cars a day. The line includes three different body models, finished in five different color combinations. The power plant consists of a Golden, Belknap & Swartz engine with a Grant-Lees clutch and gear box. It is fitted with a floating axle and the wheel base is 108 in. A Disco lighting and starting outfit is used and a Splittorf-Dixie magneto for ignition. Two special features in the construction are a fuse box on the dash and the use of genuine leather in the upholstery.

Monarch to Be Built in Hyattsville

Monarch cars will be manufactured in Hyattsville, Md., as soon as all the machinery and materials arrive. The Carter Brothers Co. has secured the exclusive rights of the Monarch Motor Car Co., Detroit, and will build both Monarch models, an eight and a twelve. In addition to the above standard models a new design of light car will be added to be known as the Monarch Midget. The business of the Monarch company will be continued under the Monarch Motor Car Co., a subsidiary organization of the Carter Brothers Co.

Ford Co. Raises Probation Salaries

The Ford Co., Detroit, has raised the salaries of workmen laboring under the probation system to 43 cents an hour, an increase of 9 cents over the former rate of 34 cents per hour. Ford employes are placed on a probation basis for six months and do not receive the \$5 a day salary until they qualify through the probation. As the Ford work day is 8 hours, probationers now receive \$3.44 per day in place of \$2.72. The raise was made because of the increased cost in living.

All women workers in factories and offices will receive the same wages as the men, \$5 per day after probation.

To Build Charter Oak Car

The Eastern Motors Syndicate, organized some time ago for the development of a high grade automobile, at Hartford, Conn., has the designing work well advanced and plans are practically completed for construction of a building for manufacturing purposes. The car will be known as the Charter Oak in honor of the city of Hartford, where the famous tree was located. The manufacturing organization, which will be known as the Eastern Motors, Inc., will take over the present syndicate and has been incorporated for \$1,000,000.

Lozier Bros. Co. Organize \$10,000,000 Company

Harry A. Lozier, former president of the Lozier Motor Car Co., and who recently retired as president of the H. A. Lozier Co., Cleveland O., has launched a new company, the Lozier Bros. Co., capitalized at \$10,000,000. New York and Philadelphia capital is stated to be behind the company. Only 25 per cent of the capital is to be issued at present, the balance being reserved for subsequent disposal in expanding the business. The incorporators are F. R. Hansell of Philadelphia and G. H. B. Martin and S. C. Zymour of Camden, N. J.

Meeting of Carriage Builders in Cincinnati

Pursuant to call, there was held a meeting of carriage manufacturers in the Hotel Gibson, Monday, September 25, 1916, for the purpose of discussing matters of vital interest to the industry. The meeting was called to order by P. E. Ebrenz, St. Louis, acting as chairman; G. W. Huston was elected secretary. After a brief discussion a motion was made to adjourn until Wednesday, September 27.

The adjourned meeting was called to order Wednesday afternoon at 2 o'clock by Chairman P. E. Ebrenz, G. W. Huston acting as secretary. Those present engaged in an informal discussion in regard to many matters of interest to the trade, especially the necessity of increasing the price of vehicles owing to the increased cost of material. No concerted action was taken, the matter being left to the individual decision of the carriage builders.

A motion was made by W. H. Roninger that the organization be made permanent, and that regular meetings be held every three months. After some discussion it was decided to leave the calling of the next meeting to the incoming president.

The following is a list of those who were in attendance:

P. E. Ebrenz, Reliance Buggy Co., St. Louis, Mo.
 C. R. Crawford, Moon Bros. Carriage Co., St. Louis, Mo.
 E. E. Hughes, Hughes Buggy Co., Lynchburg, Va.
 Chas. A. Smith, Colonial Carriage Co., Circleville, O.
 W. J. Glunt, Ross Carriage Mfg. Co., Union City, Ind.
 S. H. Barrett, Poste Bros. Buggy Co., Columbus, O.
 E. A. Johnson, Eckhart Carriage Co., Auburn, Ind.
 A. H. Ahlbrand, Ahlbrand Carriage Co., Seymour, Ind.
 O. L. Ahlbrand, Ahlbrand Carriage Co., Seymour, Ind.
 L. C. Fehring, Fehring Carriage Co., Columbus, Ind.
 W. H. Fehring, Fehring Carriage Co., Columbus, Ind.
 Frank Delker, Delker Bros. Buggy Co., Henderson, Ky.
 Ed. Schlamp, George Delker Co., Henderson, Ky.
 George Gerstenslager, Gerstenslager Co., Wooster, O.
 G. B. Smith, F. A. Ames Co., Owsnboro, Ky.
 M. Hission, Union City Carriage Co., Union City, Ind.
 W. H. Roninger, Banner Buggy Co., St. Louis, Mo.
 O. M. Baum, Ligonier Carriage Co., Ligonier, Ind.
 John Gummer, Noyes Carriage Co., Elkhart, Ind.
 Thomas Parry, Parry Mfg. Co., Indianapolis, Ind.
 James B. Haler, Harper Buggy Co., Columbia City, Ind.
 Theo. Luth, Luth Carriage Co., Cincinnati, O.
 Ed. Moore, Moore Buggy Co., Fayetteville, Tenn.
 C. E. Adams, Cleveland Hardware Co., Cleveland, O.
 Samuel Nichols, Empire Buggy Co., Jackson, Ga.
 W. A. Sayers, Sayers & Scovill Co., Cincinnati, O.
 W. P. Champney, Eberhard Mfg. Co., Cleveland, O.
 Thos. Sechler, D. M. Sechler Implement Co., Moline, Ill.
 John Delker, John Delker Co., Henderson, Ky.
 W. G. Norman, Norman Buggy Co., Griffin, Ga.
 A. M. Parry, Parry Mfg. Co., Indianapolis, Ind.
 P. P. Hunter, American Carriage Co., Cincinnati, O.

There being no further business, a motion was made and duly seconded that the meeting adjourn.

National Implement and Vehicle Association

The twenty-third annual convention of the National Implement and Vehicle Association opened on October 18, and was brought to a close the evening of October 20 with the annual banquet. It was one of the most successful meetings the organization ever held.

More than 250 persons attended the convention. This

number included practically the entire membership of the organization, a large number of members of the Auxiliary to the N. I. & V. A., and a large number of the fair sex. The business meetings were well attended, while the entertainment features were on a more magnificent scale than any attempted heretofore.

Thursday morning's meeting was given over to the consideration of manufacturing and selling costs; the afternoon session was occupied with the consideration of foreign trade and cash sales; Friday morning's session provided ample opportunity for the study and discussion of agricultural extension. The closing meeting was devoted entirely to the reports of the various appointive committees, election of officers, and the selection of Atlantic City as the next place of meeting.

This convention marked the first opportunity for a closer acquaintance between the implement men and the hardware manufacturers and hardware jobbers. The two latter organizations were in convention at the Marlborough-Blenheim Hotel at the same time that the National Implement and Vehicle Association was meeting in the Hotel Traymore. On Wednesday evening these three organizations were entertained in a joint party at Young's Million Dollar Pier.

The election of officers resulted in the selection of Joseph Dain, Moline, Ill., president, and C. S. Brantingham, Rockford, Ill., chairman of the executive committee. Members of the executive committee and a long list of vice-presidents were also chosen, and W. C. Nones, Louisville, Ky., and John W. Stoddard, Dayton, O., were elected to honorary membership.

Brunswick Motor Car Co. Formed

The Brunswick Motor Car Co. has been formed with a capitalization of \$500,000 to produce an assembled automobile selling at \$1,950, f.o.b. Newark, N. J. A four-cylinder Wisconsin engine, 4¾ x 5½, with a Rayfield carburetor is used. Other features are: Fedders radiator, Bosch magneto, Westinghouse starting and lighting, Brown-Lipe gearset, Timken axles, and Parish & Bingham frame. It also uses Gemmer steering gear, Stewart vacuum feed, and Silvertown cord tires. Drive is Hotchkiss type.

The body is of a high quality job, all rear compartment woodwork being of mahogany, as is the instrument board. There are also five mahogany cabinets in the rear compartment, containing a set of Thermos bottles, sandwich tins, and room for other articles. Each cabinet has a Yale lock. Two Waltham clocks are furnished, one on the instrument board and one in front of the rear compartment.

Russel Smith is president of the company, Everett Cadmus is vice-president, J. T. Bunt is secretary, and A. V. Weeks is treasurer. The company is temporarily using a plant of 15,000 sq. ft. floor space, but a new plant will later be established along the Pennsylvania Railroad tracks outside of Newark. From 500 to 1,000 cars will be produced during the coming year.

Dudley Ad. Manager for Federal

Lynn B. Dudley has been appointed advertising manager of the Federal Motor Truck Co., succeeding George W. Cushing, who recently joined the Hudson Motor Car Co. Dudley had been handling the Federal account for the Campbell-Ewald Co.

New C. B. N. A. Members

The following are the names of new members of the Carriage Builders' National Association, submitted by Secretary Henry C. McLearn since making his report at the convention in Cincinnati in September:

Active Members

Albert Armstrong, The A. Armstrong Co., Cincinnati, O.
 A. L. Black, A. Wrenn & Sons Co., Norfolk, Va.
 N. J. Baxter, The Baxter Buggy Co., Hampton, Ga.
 C. R. Crawford, Moon Bros. Carriage Co., St. Louis, Mo.
 L. C. Fehring, Fehring Carriage Co., Columbus, Ind.
 M. C. Hission, Union City Carriage Mfg. Co., Union City, Ind.
 John B. Hower, The Akron-Selle Co., Akron, O.
 R. J. Jones, The Henderson Buggy Mfg. Co., Henderson, N. C.
 J. R. Knight, Knight Buggy Co., Franklin, Va.
 J. A. Moores, Moores Buggy Co., Fayetteville, Tenn.
 Thomas J. McNamara, Phoenix Buggy Co., Cincinnati, O.
 W. B. Pratt, Elkhart Carriage and Motor Co., Elkhart, Ind.
 S. W. Rowland, Rowland Buggy Co., Sumter, S. C.
 James C. Strong, Montgomery, Ward & Co., Chicago Heights, Ill.
 H. H. Wood, Eureka Co., Rock Falls, Ill.

Associate Members

J. L. Adams, Cambria Steel Co., Cincinnati, O.
 W. J. R. Alexander, Wright Varnish Co., Cincinnati, O.
 G. C. Foster, Evansville Woodstock Co., Evansville, Ind.
 John W. Herron, Royer Wheel Co., Aurora, Ind.
 J. F. Howerton, The Ohio Valley Tanning Co., Cincinnati, O.
 Richard Hirst, The Hirst-Rogers Co., Philadelphia, Pa.
 W. A. Jacob, Cincinnati Varnish Co., Cincinnati, O.
 Carl Kloos, Enterprise Brass and Plating Co., Cincinnati.
 J. Lichtenaur, Standard Varnish Co., Cincinnati, O.
 S. W. Mitchell, Mitchell Wheel Co., Miamisburg, O.
 W. O. Rutherford, The B. F. Goodrich Co., Akron, O.
 C. J. Rennekamp, The Auto Vehicle Parts Co., Newport, Ky.
 F. H. Sawyer, The Goodyear Tire and Rubber Co., Akron, Ohio.
 L. C. Vaughn, James R. Rhodes & Co., Chicago, Ill.
 Roger Williams, The Keystone Spring Works, Philadelphia, Pa.

Federation of Implement and Vehicle Dealers' Associations

The seventeenth annual convention of the National Federation of Implement and Vehicle Dealers' Associations was held at the Sherman Hotel in Chicago, October 11-13. The attendance was larger than for some years, and all but two of the member associations were represented.

The dealers' associations which sent delegates were as follows: Iowa Implement Dealers' Association, Illinois Implement and Vehicle Dealers' Association, Michigan Implement and Vehicle Dealers' Association, Mid-West Implement Dealers' Association, Minnesota Implement Dealers' Association, Mississippi Valley Implement and Vehicle Dealers' Association, North Dakota Implement Dealers' Association, Ohio Implement Dealers' Association, South Dakota Implement Dealers' Association, Tri-State Vehicle and Implement Dealers' Association, Texas Hardware and Implement Association, Western Retail

Implement, Vehicle and Hardware Association, Wisconsin Implement and Vehicle Dealers' Association.

The usual routine business of the organization was transacted and many interesting reports were received from officers and standing committees. The election of officers for the ensuing year, which occurred on the last day of the convention, resulted in the choice of the following: President, C. M. Johnson, Rush City, Minn.; vice-president, William L. Derry, Vermont, Ill.; directors, E. P. Armknecht, Donnellson, Ia., and M. D. Thompson, Vermillion, S. D. T. J. Turley, Owensboro, Ky., was chosen to fill a vacancy in the board of directors, occasioned by the advancement of Mr. Derry to the vice-presidency.

Will Bring Out New Engine

The Herschell-Spillman Company, North Tonawanda, N. Y., is going to bring out a 3¼ x 5 L-head four-cylinder engine for truck and small car use, and will have capacity to build about 15,000 to 20,000 of these motors per year. The details are now being worked out by E. O. Spillman, and the company claims it will have something that will maintain its high reputation for good motors. The price has not been definitely decided upon but will be in line with other motors of its class. While details are not yet complete the company hopes to have samples ready for distribution about January 1.

With its new plant comprising a total floor space of nearly four acres and the installation of the most up-to-date machinery which will be purchased especially for the manufacture of this one model, the company claims it will be in shape to make deliveries on time.

Emil Grossman Expansion

Emil Grossman has reorganized the Emil Grossman Mfg. Co., Brooklyn, N. Y., reincorporating it as the Emil Grossman Mfg. Corporation, with \$310,000 capital stock. The stock is divided into \$150,000 first preferred, \$160,000 second preferred, and there are also 10,000 shares of common stock of no par value. Grossman is president of the company; L. M. Schwartz is vice-president; Harmon August, treasurer; and C. L. Hemphill, assistant treasurer and secretary. The expanded program of the company will result in a concentration of activities on the production of Red Head spark plugs and Ever Good bumpers and mirrors in increasing quantities. Additional manufacturing facilities are to be secured.

Skilled Labor Shortage

Shortage of skilled labor is general throughout Wisconsin. The motor car and truck industry is feeling the result. The Four Wheel Drive Auto Co., Clintonville, Wis., is advertising heavily in Milwaukee and Chicago newspapers for 50 turret and engine lathe, milling machine and drill press operators; ten bench hands; ten assemblers, and two inspectors, but has been able to get only a very small number of men. From 800 to 1,200 skilled machinists would be given immediate employment if they were available.

Studebaker Price Advanced

Announcement has been made by the Studebaker Corporation that the prices of Studebaker cars, both the four and the six, will be advanced from \$75 to \$100 over present prices, on or about December 1 because of increased cost of materials.

Trade News From Near and Far

General News of the Vehicle Trade

The Ghent Motor Car Co., Chicago, has purchased a plant at Ottawa, Ill., which will be remodeled for its use.

The Maxwell Motor Co. will build an assembling plant at Kansas City, Mo., to cost with equipment about \$250,000.

The Militaire Motor Vehicle Co. of America, Buffalo, N. Y., recently increased its capital stock from \$250,000 to \$650,000.

The Sidney Mfg. Co., Sidney, O., has commenced work on two additions to its plant, 45 x 100 ft., four stories, mill construction.

Sterling Automobile Mfg. Co. is rushing its plant at Amston, Conn. The company now occupies a plant in Paterson, N. J.

The Kissel Motor Car Co., Hartford, Wis., is building an auxiliary assembly shop, 40 x 100 ft., of concrete and brick, one story.

Baker Wheel and Rim Co. has been organized at Chicago; capital, \$5,000; incorporators, Erie K. Baker, Chas. G. Hawley, John R. Lefevre.

R. H. Reynolds & Co., New Albany, Ind., are erecting an automobile woodstock plant, combining two factories now at Corydon and De Pauw, Ind.

The contract for the erection of an addition to the Ford Motor Co.'s plant at Ford City, Ont., of reinforced concrete and brick, has been awarded. It is to cost \$100,000.

Packard Motor Car Co. has acquired additional property in Long Island City, adjoining its present plant, on which it will erect an eight-story building, more than doubling its present facilities.

The Parker Collapsible Rim Corporation has filed a charter at Dover, Del., under which it will manufacture and deal in rims and other parts of all kinds of vehicles. The capitalization is \$5,000,000.

The Ebbeler Motor Car Co., St. Louis, has been incorporated with a capital stock of \$100,000, by L. B. Ebbeler, Windsor Springs, Mo.; J. J. Pitlyk and L. E. Erwin, St. Louis, to manufacture automobiles.

The White Co., Ltd., Toronto, has been incorporated with a capital stock of \$40,000, by Wilfrid M. Cox, 801 Dominion Bank Bldg.; Howard A. Harrison, William J. Beattie, and others, to manufacture automobiles, etc.

Brewster & Co., Long Island City, N. Y., have increased their capital stock from \$2,000,000 to \$2,500,000, to provide funds for the manufacture of a chassis for its automobiles, formerly imported from England and France.

The Raybestos Co., Bridgeport, Conn., maker of automobiles and accessories, has been incorporated with capital stock of \$1,500,000. The incorporators are S. Simpson, L. V. Simpson and H. G. Farwell, all of Bridgeport.

The Mogul Wagon Works, at Hopkinsville, Ky., which has a normal annual capacity of 10,000 finished wagons, started to working both night and day shifts in order to

keep up with the large amount of business they are receiving.

The Maibohm Wagon Co., Racine, Wis., is now building automobiles, the Maibohm Motors Co. having been organized for that purpose. The product will be exclusively a light roadster type, selling for \$695, and trade-marked "Maibohm."

The Hayes Wheel Co., Jackson, Mich., has increased its capital stock from \$1,000,000 to \$1,500,000, and is preparing to manufacture wire wheels in addition to its present output of 1,000,000 sets a year. C. B. Hayes is president and general manager.

The Brunswick Motor Car Co., Maywood, N. J., has been incorporated with a capital of \$500,000, to manufacture automobiles, engines, etc. Alden V. Meeks, Maywood; James T. Bunt, Norwood, and Russell Smith, New York, are the incorporators.

The Disco Electric Starter Corporation, Detroit, will begin the erection of a new factory with more than 28,000 sq. ft. of floor space which will triple its output, according to an announcement made by President S. W. Elston. Sol. Meyer, Detroit, is treasurer.

The Kelsey Wheel Co., North Memphis, Tenn., and Detroit, Mich., will consolidate its factories, bringing the Detroit plant to Tennessee. This will increase the capacity of the Memphis plant, which is now producing 2,000 complete automobile wheels daily.

The Kent Motors Corporation, 1790 Broadway, New York City, recently incorporated, has increased its capital stock from \$100,000 to \$2,000,000, to provide for the erection of its proposed automobile manufacturing plant on property acquired on Washington avenue, Belleville, N. J.

The Reo Motor Car Co., Lansing, Mich., has received materials to rush work on its new three-story addition, 175 x 407 ft. It has a consignment of \$30,000 worth of lathes, part of this being reserved for the new machine shop. Other machinery will be installed as soon as the addition is completed.

Doings of the Motor Truck Builders

The Ford Motor Co. of Canada, Ltd., will begin the manufacture of trucks in March, 1917.

The Globe Motor Truck Co., Detroit, has been incorporated by Spencer Clark, Robert C. Yerkes and Charles A. Dolph.

The Packard Motor Car Co. of New York, has opened a used motor truck department at 239-241 West Fifty-sixth street.

Eugene Goldman, Chicago Republic truck dealer, is severing his connection with that company and has organized his own company to build trucks.

Stockholders of the Globe Motor Truck and Body Co. met November 3 and organized the Ypsilanti (Mich.) Motor Truck Co., with a capitalization of \$100,000.

The Commercial Car Unit Co., Philadelphia, has been incorporated with a capital of \$10,000, to manufacture motor trucks. N. S. Mackie, Philadelphia, is treasurer.

The General Motors Truck Co., Pontiac, Mich., announces plans for doubling its factory capacity during the year. A track system of assembling will be immediately installed.

The Hayes Motor Truck Wheel Co., St. Johns, Mich., will double its factory output. A large boiler is to be installed and a new tire press and facer added to the equipment.

The Kelly-Springfield Motor Truck Co., Springfield, O., has increased its capital stock from \$1,740,000 to \$7,000,000. Additions to its plant are planned that will nearly double the capacity.

The Pullman Motor Truck Co. has been organized in New Castle, O. with a capital of \$600,000, the concern having purchased a site on the Gibson farm, along the Butler Avenue Road.

Robert Kirk, Jr., has purchased from the board of education the Central school building at Findlay, O., and will convert it into an automobile manufactory, taking care of light trucks and light touring cars.

Shipments of the Republic Motor Truck Co., Alma, Mich., amounted to 626 trucks in October, compared with 190 in 1915 and 35 in 1914. For the first ten months of this year the shipments were 4,902 trucks, against 1,442 in the corresponding period of last year.

The Four Wheel Drive Auto Co., Clintonville, Wis., is spending approximately \$20,000 in new tools and equipment for additions now being completed. It has a standing order for 20 trucks per week for an indefinite period and is now producing four a day. By January 1 the output is to be six a day.

Kenosha, Wis., is to have another big motor company—the Winther Motor Truck Co., with a capital of \$330,000. The company is headed by Martin P. Winther, for many years prominently connected with the truck department of the Thomas B. Jeffery Co. The company has purchased $3\frac{1}{2}$ acres of land just west of the city and will be ready for business by the middle of April.

N. L. Le Blond, formerly secretary and general manager of the Hannibal Motor, Wagon & Body Co., Hannibal Mo., has been made western manager of the Dearborn Motor Truck Co. and will make his headquarters at Kansas City. Augustine Gilmore, formerly of Chicago, succeeds Mr. Le Blond in the Hannibal company as general manager, Miss Hattie Salee being made secretary.

The Duplex-Power Co., Charlotte, Mich., manufacturers of auto trucks, announces a special meeting of the stockholders to be held at the office of the company on November 20, for the purpose of considering the question of selling and transferring all of the assets, rights and properties of the company to a corporation now being organized for the purpose of taking over the properties and assets of the corporation.

C. E. Collard, formerly Philadelphia branch manager of the Chase Motor Truck Co., and C. N. Gillette, southern division sales manager in the same organization, have severed their connections with that company to become associated with the Selden Truck Sales Co., Rochester, N. Y. Mr. Collard becomes division sales manager in the Philadelphia territory, while Mr. Gillette assumes the same

position in the southern territory, with headquarters at Charlotte, N. C.

The Corliss (Wis.) Motor Truck Co. is now ready to supply a new type of small truck of 1,000 lbs. capacity selling for \$695. It has an all-steel body, combined with the frame in such a way as to make the body a strength factor in the chassis. The engine fitted is a four-cylinder $3\frac{1}{8} \times 4\frac{1}{2}$ in. and there is a three-speed gearset with selective shift. The rear axle is bevel-driven, three-quarter floating and has double roller bearings to carry the load. Elliptic springs are used and pneumatic tires 31×4 in., the wheelbase being 100 in.

The Milwaukee Locomotive Mfg. Co., Milwaukee, Wis., pioneer builder of gasoline locomotives, is placing on the market a new type of gasoline truck tractor similar in appearance and uses to the electric industrial trucks in use by various railroads. It is intended for the handling of freight at railway terminals, steamship docks and freight houses. Power is supplied by a four-cylinder, vertical, block engine with a bore and stroke of $3\frac{3}{4}$ and $4\frac{1}{2}$ in., power being transmitted through a bevel gear differential and external gear-drive axle. The truck will transport 4,000 lbs. on its platform and will haul a trailer load of $3\frac{1}{2}$ tons.

Body Builders Briefs

Jonesville, Mich., will have a new factory for the manufacture of auto bodies.

The Continental Auto Top Mfg. Co., St. Louis, has doubled its capital stock and will extend its manufacturing plant.

The American Body Co., Buffalo, N. Y., is building a two-story brick addition to its factory at Niagara and Breckinridge streets.

Charles Drum has been made the superintendent of production for the Springfield Body Co. Mr. Drum was formerly connected with the Haynes Mfg. Co.

The Commercial Body Co., Trenton, N. J., manufacturer of bodies for automobiles, has acquired property at 809 South Broad street for an addition to its plant.

W. Leahy, of Albany, N. Y., has disposed of his holdings in the Kingsbury-Leahy Co., designer and builder of automobile bodies, to devote his attention to other business interests.

In order to increase its space the Fisher Body Corporation has purchased one of the units of the factory of the Regal Motor Car Co., situated opposite the main Fisher plant in Detroit.

The Springfield Body Co. will move to its new plant at Springwells, near Detroit, by Feb. 15 and will have a capacity of 100 bodies per day. At present the company has a capacity for 35 bodies daily.

The Troy Mfg. Co. has purchased the factory known as plant 5 of the Studebaker Corporation, at Detroit, for \$100,000. The Troy company will use the factory for the manufacture of automobile bodies.

Simplex Automobile Co., New Brunswick, N. J., is planning the erection of a new plant for the manufacture of automobile bodies. A new factory for the manufacture of aeroplanes is also under consideration.

The Commercial Auto Body Co., Bay City, Mich., has been organized by W. B. Fitzgerald, Henry Kinney, Robert Woodsworth, A. E. Hubbell and others, to develop an

automobile body business. A factory will be erected at once.

C. F. Barth has been made works manager of the C. R. Wilson Body Co., Detroit. G. D. Wilson has been made manager of production and sales, and will also have charge of the inspection department. For the past four years he has been production manager.

A new high record was established by the Fisher Body Corporation, Detroit, in October, when the sales amounted to \$1,470,000, compared with \$773,000 in October, 1915, an increase of 90.12 per cent. For the eight months ended October 31 last the sales increased 79.74 per cent.

The Harvey Top & Body Co., Buffalo, recently incorporated for the manufacture of automobile bodies and tops, has taken over the plant and business of Bosche Brothers, Main and Summer streets, and will make improvements. Henry C. Harvey, 918 Main street, is secretary and general manager.

The Detroit Weatherproof Body Co., Detroit, recently organized with a capital stock of \$200,000, is constructing several additions to its factory on Mount Elliott avenue. It is reported that its entire output for the remainder of the year has been sold to automobile factories, and work on the additions is being rushed to provide for next year's business.

Haynes to Have New Building

The board of directors of the Haynes Automobile Co., Kokomo, Ind., has authorized A. G. Sieberling, general manager, to prepare plans for a new building and to buy machinery for a capacity of 100 cars daily. Contracts will be let for buildings which will have a capacity of three times the number of cars made at present. The new buildings will have about 600,000 sq. ft. of floor space, which will be added to 350,000 sq. ft. now in operation in the company's plant.

\$2,000,000 Plant for Cadillac

The Cadillac Motor Car Co., Detroit, Mich., has purchased a 40-acre site formerly owned by the American Car & Foundry Co. and will erect a new factory for the construction of Cadillac cars. The projected plant, upon completion, will entail an investment in buildings and machinery of approximately \$2,000,000. The company plans to employ about 12,000 men in the new factory. At present the company has 8,000 employees.

Anderson Buys Chicago Electric

The Anderson Electric Car Co., Detroit, has purchased the Chicago Electric interests of the Walker Vehicle Co. and will shortly take over all the new Chicago Electrics completed and those in process of manufacture, together with all parts and service. The Walker Vehicle Co., which is owned by the Commonwealth Edison Co., will devote its efforts to the building and selling of Walker electric trucks.

Ghent Company Buys Plant

The Ghent Motor Co. has purchased the Gay factory at Ottawa, Ill., and will immediately prepare it for production of a four and eight-cylinder car. The Ghent company has been building cars for a year and a half in Chicago.

To Revive Arbenz Car

The Arbenz Motor Car Co. of Chillicothe, O., incorporated under the laws of that state, with a capital of \$1,000,000, will resume the manufacture of the Arbenz car, which has not been on the market for several years. The new concern has taken over the old Arbenz Car Co. M. F. McFadden, E. C. Spoder, M. C. Hayes, W. J. Purcell and R. I. Pillars are the incorporators.

Railroad Uses Studebaker for Special Work

By removing the ordinary wheels and substituting metal flanged wheels on a Studebaker four, the Maryland and Pennsylvania Railroad converted the car for rail use by inspectors. The car runs 40 miles per hour, operates on railroad schedule and averages 22 miles to the gallon of gasoline.

Columbia Motors to Make Light Six

The Columbia Motors Co., which recently acquired a plant in Detroit, where the Columbia light six, a five-passenger car, will be manufactured, will have machines on exhibition at both the National Automobile Shows in New York and at Chicago. The car is to be an assembled product and will sell at somewhere near \$1,000.

Pullman Price Up \$85

The price of the four-cylinder Pullman car, manufactured by the Pullman Motor Car Co. of York, Pa., has been advanced to \$825, an increase of \$85. Three body types will be marketed, a two-passenger roadster, four-passenger roadster and a five-passenger touring car. Green will be the standard color finish.

Brewster Joins N. A. C. C.

Brewster & Co., famous as carriage builders for half a century or more, and who two years ago began the making of a car equipped with a Knight engine, have been admitted to membership in the National Automobile Chamber of Commerce. The Brewster plant is located in Long Island City, N. Y.

Make 1,000 Sets of Wheels in a Day

The Hayes Wheel Co. recently built 1,000 sets of Ford wheels in one day at its Anderson, Ind., plant. The 4,000 wheels were produced by the regular force of 300 men running day turn. A night shift of 300 employees is to be added so that the required capacity of 2,000 sets of Ford wheels daily may be reached.

King Adds \$50 to Prices

The King Motor Car Co., Detroit, has officially announced an advance of \$50 on the list price of the eight-cylinder King car, to become effective November 15. This brings the price of the seven-passenger touring car and three passenger roadster to \$1,400 each, and the sedan to \$1,950, all f.o.b. Detroit.

\$9,000,000 for Freight Cars

The Michigan Central Railroad has just closed a contract for the construction of 6,750 freight cars, of which 4,000 will be cars equipped for carrying automobiles.

Malleable Castings and Woodwork

When attaching malleable iron castings to woodwork for carriage or wagon purposes, the better the contact between the iron and the wood the better and more lasting will be the joint obtained when the bolt which holds the wood to the casting is screwed home. If the casting only touches the wood in a few places, continual wear of the vehicle will cause the wood to fit itself more closely to the metal, and it will be necessary to screw up the nut of the bolt which holds the parts together. Therefore, take as much care as possible when fitting malleable castings to wood, and, if possible, rub the parts together. This may be done by first rubbing the face of the casting with blue or red chalk or with red lead mixed with oil. Then rub the casting back and forth for a small fraction of an inch over the part where it is to be bolted fast, and it will easily be seen where the two touch each other.

Using Sandpaper Properly

Many persons do not know that there is a right and wrong way to cut a sheet of sandpaper in two, says The Woodworker. The right way is to fold it evenly, with the sanded part inside, which will prevent cracking or uneven folding. Then cut with a knife, pulling the blade against the sanded paper. For sanding off surfaces, say those which are large and level, it is best to use a block of soft wood, about 2½ x 3½ in. To one side of the block glue a piece of rubber belting, or sheet rubber of some sort, and, when the glue has become dry, saw the block into a series of slits, 3/16 in. apart and to within about 1/8 in. of the rubber. The purpose of these slits is to make the block flexible, which will enable it to fit into a concaved or other shaped surface. Still another and similar block may be made solid, for sandpapering large, even surfaces.

British Government Requisitions Leather

According to a cablegram from the American consul general at London, dated September 30, notice has been given that the War Office intends to take possession of all leathers, finished or unfinished, of the following classes: Vegetable tanned bends of 6 pounds and upwards, butts of 12 pounds, backs of 8 pounds, vegetable tanned shoulders, medium and heavy butts of 1½ millimeters substance and upwards, kip sides except semichrome; also vegetable grained upper leathers, chrome leather, and upper leathers of any other process of 1½ millimeters substance. Sale or removal of any such leathers subject to permission from director of army contracts.

WANTS

Help and situation wanted advertisements, 1 cent a word; all other advertisements in this department, 5 cents a word; initials and figures count as words. Minimum price, 30 cents for each advertisement.

PATENTS

Patents—H. W. T. Jenner, patent attorney and mechanical expert, 606 F St., Washington, D. C. Established 1883. I make a free examination and report if a patent can be had and exactly what it will cost. Send for circular.

Index To Advertisers

Acme Die-Casting Corporation.....	4
Acme Rubber Mfg. Co.....	40
Anti-Borax Comp. Co.....	Back cover
Barrell Co., Wm. L.....	40
Bliss, E. W. Co.....	3
Bookwalter Wheel Co.....	42
Bradley, C. C., & Son.....	41
Brawley, T. R.....	2
Brennan Motor Mfg. Co.....	43
Cargill Co., The.....	42
Columbus Bolt Works.....	Back cover
Cowles, C., & Co.....	42
Decker, J. C.....	42
Doehler Die-Casting Co.....	4
Dowler, Chas. L.....	42
DuPont Fabrikoid Co.....	39
Eccles, Richard, Co.....	39
Fairfield Rubber Co.....	43
Felton, Sibley & Co., Inc.....	Back cover
Hoopes Bro. & Darlington.....	43
Hotel Brunswick	41
Hotel Cumberland	42
Hotel Tuller	8
International Rubber Co.....	41
Jenner, H. W. T.....	38
Johnston Paint Co.....	42
Keratol Co., The.....	40
Laidlaw Co., The.....	40
Lumen Bearing Co.....	7
Meyer, John C., Co.....	2
Millersburg Fifth Wheel Co.....	42
Mulholland Co., The.....	42
Murcott-Duden Co., The.....	8
Parrott Varnish Co.....	42
Parsons Mfg. Co.....	3
Payne, E. Scott, Co.....	42
Porter, H. K.....	40
Pressed Steel Co. of New York.....	2
Rome-Turney Radiator Co.....	4
Russell, Burdsall & Ward Bolt & Nut Co.....	41
St. Marys Wheel & Spoke Co.....	2
Sheldon Axle & Spring Co.....	Front cover
Sherwin-Williams Co., The.....	6
Shortsville Wheel Co.....	2
Skinner, J. M., Bending Co., The.....	6
Smith, H. Collier.....	40
Standard Oil Cloth Co., Inc.....	5
Technical School for Automobile Draftsmen.....	41
Valentine & Co.....	Back cover
West Tire Setter Co.....	43
White-Quehl Mfg. Co.....	42
Wilcox Mfg. Co., D.....	40
Willey Co., C. A.....	43
Williams, J. H., & Co.....	8
Wing, Chas., Co.....	42

High Grade Forgings

for CARRIAGE, WAGON, AUTO-MOBILE and SPECIAL WORK

ECCLES BALL-BEARING COUPLINGS are the BEST on the MARKET for DURABILITY and EASE OF ADJUSTMENT

LEATHER BUSHINGS ARE FAST-ENED IN THE SOCKET WHERE THEY BELONG

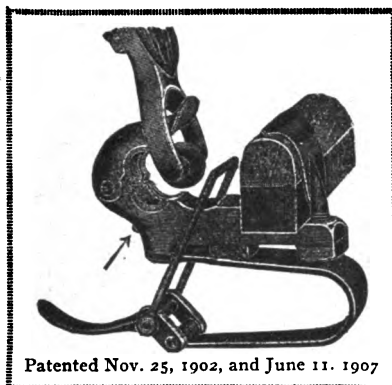

Patented Nov. 25, 1902, and June 11, 1907

SPECIAL FEATURE—THE SPRING IS PIVOTED AT THE FRONT TO ALLOW EASY ADJUSTMENT

Please bear in mind that we make a FULL LINE of Carriage and Wagon Forgings, also many of those for Auto and Special Work.

Send for our new Catalogs showing our Regular and Special Forgings.

QUALITY GUARANTEED.

SERVICE—THE BEST

Richard Eccles Co.

AUBURN, NEW YORK



RAYNTITE

Is Right on Top

Because RAYNTITE is a light weight, strong, water and weather proof, single texture topping guaranteed for one year, but made to last the life of the vehicle.

Adopt RAYNTITE—the continuously advertised, warranted fabric and you have a superior product that will meet your demands with absolute satisfaction.

MOTOR QUALITY FABRIKOID is the standard vehicle upholstery.

Write for samples and full information

Du Pont Fabrikoid Co.

Wilmington, Delaware
Toronto, Ontario

CLASSIFIED INDEX

For Addresses See Alphabetical Index and Advertising Pages

AUTO FABRICS

- Acme Rubber Mfg. Co., Trenton, N. J.
- Barrell, Wm. L., Co., New York
- Fairfield Rubber Co., Fairfield, Conn.
- International Rubber Co., New York City.
- Keratol Co., The, Newark, N. J.
- Laidlaw Co., Inc., The, New York.
- O'Bannon Corporation, New York City.
- Standard Oil Cloth Co., New York City.

AXLES (Including Ball and Roller Bearing)

- Sheldon Axle & Spring Co., Wilkes-Barre, Pa.

BOLTS AND NUTS

- Columbus (O.) Bolt Works Co.
- Russell, Burdsall & Ward Bolt & Nut Co., Port Chester, N.Y.

BOLT CLIPPERS

- Porter, H. K., Everett, Mass.

BRAZING SLEEVES

- White-Quehl Mfg. Co., Cincinnati, O.

BRONZE BEARINGS

- Lumen Bearing Co., Buffalo.

CLOCKS

- Hartford Clock Co., Inc., New York City.

DIE CASTINGS

- Acme Die Casting Corp., Brooklyn, N. Y.
- Doehler Die Casting Co., Brooklyn, N. Y.

FIFTH WHEELS

- Millersburg Fifth Wheel Co., The, Millersburg, Pa.
- Wilcox Mfg. Co., D., Mechanicsburg, Pa.

HARDWARE (Carriage, Wagon and Automobile)

- Columbus (O.) Bolt Works Co.
- Dowler, Chas. L., Philadelphia.
- Eccles Co., Richard, Auburn, N. Y.
- Wilcox Mfg. Co., D., Mechanicsburg, Pa.
- Wing Co., Chas., Amesbury, Mass.
- Cowles, C., & Co., New Haven, Conn.
- Parsons Mfg. Co., Detroit, Mich
- Payne Co., E. Scott, Baltimore.

LEATHER SUBSTITUTES

- Barrell Co., Wm. L., New York.
- International Rubber Co., New York City.
- Keratol Co., The, Newark, N. J.
- O'Bannon Corp., New York.
- Standard Oil Cloth Co., New York.
- DuPont Fabrikoid Co., Wilmington, Del.

MACHINERY AND TOOLS

- Bliss Co., E. W., Brooklyn, N.Y.
- Smith, H. Collier, Detroit, Mich.
- West Tire Setter Co., Rochester, N. Y.
- Williams, J. H., & Co., Brooklyn, N. Y.
- White-Quehl Mfg. Co., Cincinnati, O.

MACHINERY (Metal Working)

- Bliss Co., E. W., Brooklyn, N.Y
- Smith, H. Collier, Detroit, Mich

METAL STAMPINGS AND NOVELTIES

- Murcott-Duden Co., Inc., New York.
- Pressed Steel Co. of New York, New York City.

MOTORS

- Brennan Motor Mfg. Co. Syracuse, N. Y.

PATENTS

- Jenner, H. W. T., Washington, D. C.

PAINTS AND COLORS

- Felton, Sibley & Co., Inc., Philadelphia, Pa.
- Johnston Paint Co., R. F., Cincinnati, O.
- Sherwin-Williams Co., Cleveland, O.
- Valentine & Company, 456 4th Ave., New York; 343 S. Dearborn St., Chicago; 74 Pearl St., Boston.
- Willey Co., C. A., Hunter's Point, N. Y.

PASTE

- Indianapolis (Ind.) Paste Co.

RADIATORS

- Rome-Turney Co., Rome, N. Y.

SCHOOL FOR DRAUGHTSMEN

- Mechanics' Institute, New York

SHAFT COUPLINGS

- Bradley & Son, C. C., Syracuse, N. Y.
- Eccles Co., Richard, Auburn, N. Y.

SPRINGS

- Mulholland Co., Dunkirk, N. Y.
- Sheldon Axle & Spring Co., Wilkes-Barre, Pa.

THREADS

- Meyer, Jno. C. & Co., Lowell, Mass.

VARNISH AND JAPAN

- Felton, Sibley & Co., Inc., Philadelphia, Pa.
- Parrott Varnish Co., Bridgeport, Conn.
- Sherwin-Williams Co., Cleveland, O.
- Valentine & Company, 456 4th Ave., New York; 343 S. Dearborn St., Chicago; 74 Pearl St., Boston.
- Willey Co., C. A., Hunter's Point, N. Y.

WELDING COMPOUND

- Anti-Borax Compound Co., Ft. Wayne, Ind.

WHEELS

- Bookwalter Wheel Co., Miamisburg, O.
- Hoopes Bros. & Darlington, Inc., West Chester, Pa.
- St. Mary's Wheel & Spoke Co., St. Mary's, O.
- Shortsville (N. Y.) Wheel Co.
- Smith Wheel, Inc., [Metal], Syracuse, N. Y.
- Zwick & Greenwald Wheel Co., Dayton, O.

WOOD BENDINGS, WHEEL STOCK, ETC.

- Columbus (O.) Bending Co.
- St. Mary's Wheel & Spoke Co., St. Mary's, O.
- Skinner Bending Co., J. M., Toledo, O.

The
Laidlaw Company

Inc.
New York City

.....

**Automobile
Fabrics**

.....

**A Fabric for
Every Purpose
For Closed, Open or
Convertible Bodies**

Split Leather

a substitute for and always inferior to

KERATOL

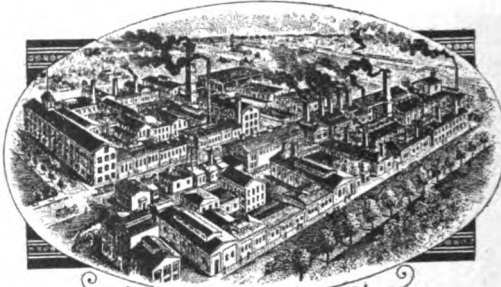

Any
Finish

All
Grains

THE HOME OF KERATOL

Nothing but hair grain leather wears better than KERATOL!

SAMPLES AND PRICES UPON REQUEST

The Keratol Co.

South and VanBuren Sts., Newark, N. J.

"Quickwork"

Sheet Metal
Working Machinery

For Automobile and Carriage Bodies, Fenders, Hoods, etc.

H. COLLIER SMITH

807-815 SCOTTEN AVE. DETROIT, MICH.

PORTER'S BOLT CLIPPERS

"Easy" "New Easy" Allen-Randall



To Cut 5-16, 3-8, 1-2, 5-8, 3-4 Inch.

H. K. PORTER, EVERETT, MASS.



QUALITY

**Automobile Top Fabrics
and Cotton Duck**

WRITE FOR SAMPLES

**WILLIAM L. BARRELL COMPANY
NEW YORK**

Acme

means

Highest Quality

in

Rubber Carriage Cloths

Acme Rubber Mfg. Co., Trenton, N. J.

WILCOX

FINE
FINISHED
FORGED

**CARRIAGE HARDWARE
AND GEAR IRONS**

Write for Prices and Catalog

The D. Wilcox Mfg. Co.

MECHANICSBURG, PA.



The Only One-piece Moulded Leather Packing

The Bradley Carriage Coupler

All-Steel Noiseless Quick-Shifting Ball-Bearing

(MADE IN FIVE SIZES FOR AXLES ¼ INCH TO 2¼ INCH)

The only carriage coupler that is furnished with a ONE-PIECE MOULDED LEATHER PACKING

C. C. BRADLEY & SON, Syracuse, N. Y.



The Bradley Carriage Coupler

Vehicle Mechanics

Desiring to improve their present Condition should attend the

TECHNICAL SCHOOL

For

Automobile Draftsmen and Mechanics

Supported by the

The National Automobile Chamber of Commerce, Inc.

The object of the School is to teach men to design vehicles and make working drawings, and to otherwise facilitate their work in the shop. Only those men employed in carriage or automobile building or their accessory trades are admitted to its privileges.

The classes are conducted in three divisions, viz.: Corresponding, Day, and Evening. The former is open during the entire year, while the day and evening classes are in session only from October 1 to April 1.

The tuition is moderate.

For prospectus and full particulars, write to the instructor,

ANDREW F. JOHNSON,
20 West Forty-fourth St.,
NEW YORK CITY

THE BRUNSWICK



Boylston Street, Corner Clarendon,
(Facing Copley Square)

BOSTON - - MASS.

High class modern house, intelligent service, pleasant rooms, superior cuisine.

Ladies traveling alone are assured courteous attention
European plan, single rooms, \$1.50 up; with bath, \$2 up; double, \$2 up; with bath, \$3 up.

American plan, \$4 per day up.

FRED E. JONES - Proprietor

RUSSELL, BURDSALL & WARD BOLT & NUT CO.

Established 1845

PORT CHESTER, N. Y.

MAKERS OF THE CELEBRATED EMPIRE BOLTS AND NUTS

Western Office: Continental & Commercial Bank Bldg., Chicago, Ill. Branch Works: Rock Falls, Ill.

"INTERNATIONAL" RUBBER CARRIAGE CLOTH

The Rubber Carriage Cloth of SERVICE and QUALITY

Write for Samples and Prices

INTERNATIONAL RUBBER CO.

120 Broadway, New York

BUSY BUYERS BRIEFS

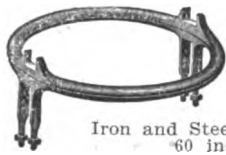

Manufacturers
**FIFTH
WHEELS**
All Varieties
Heavy Goods a
Specialty
Iron and Steel Rings from 4 to
60 inches wide
MILLERSBURG FIFTH WHEEL CO.
Millersburg, Pa.

WE MANUFACTURE
FINE VEHICLE
WHEELS
The Bookwalter Wheel Co.
MIAMISBURG, OHIO

**JOHNSTON'S
KRAKNO**
Color Card Free
\$3.50 per gallon
The R. F. Johnston Paint Co.
Cincinnati, Ohio

THE CHARLES WING CO.
Established 1848
Manufacturers and Wholesale Dealers in
**AUTOMOBILE AND CARRIAGE
HARDWARE AND TRIMMINGS**
AMESBURY, MASS., U. S. A.



The **PARROTT
VARNISH CO.**
BRIDGEPORT, CONN.
Automobile, Coach and Wagon
VARNISHES
and **VARNISH REMOVER**

Why Not Have the Best?

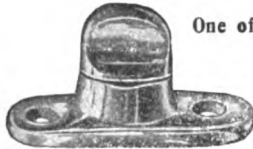

One of a Large Variety
G. Cowles & Co.
NEW HAVEN,
CONN.

J. C. DECKER
MONTGOMERY, PA.
Manufacturer of
Carriage, Skate and Pad Straps
Side Loops, Bridle Fronts, Tail Ties, etc.

SUBSCRIBE FOR
THE HUB
\$2 PER YEAR

E. SCOTT PAYNE CO.
Carriage and Automobile
HARDWARE
Horse - Shoers' Supplies
362-364 North Gay St., Baltimore, Md.

CHARLES L. DOWLER
CARRIAGE AND WAGON HARDWARE
106 North Third St., Philadelphia, Pa.
CUSHION MANUFACTURER
Pure Stearic Acid Candles. Wheel Stock. Saw
Flake Axle Grease.

**MULHOLLAND
BUGGY SPRING**
Reduces weight of springs one-half.
Made in one size only but will fit bodies
of all widths.
Write for further particulars and prices.
THE MULHOLLAND CO. DUNKIRK, N. Y.

White's Brazing Sleeves
For applying Rubber Tires
Send for Samples.
WHITE-QUEHL MFG. CO.
431 E. Pearl St.
CINCINNATI, OHIO

HOTEL CUMBERLAND

NEW YORK

Broadway at 54th Street

Near 50th Street Subway Station and 53d Street L



Broadway Cars from Grand
Central Depot.

Seventh Avenue Cars from
Pennsylvania Station.

**NEW AND FIRE-
PROOF**

Best Hotel Accommodations
in New York at Reason-
able Rates.

**\$2.50 with Bath
and Up**

EUROPEAN PLAN

All Hardwood Floors and
Oriental Rugs.

Ten Minutes' Walk to 40
Theatres

Excellent Restaurant. Prices Moderate.
Send for Booklet.

HARRY P. STIMSON

Only New York Hotel window-screened throughout

Catalog Building

Is similar to that of other prod-
ucts. The raw materials, *plus*
expert designing, *plus* competent
workmanship, *plus* the know
how (and we have had over
twenty-five years of the latter),
equal the finished article.

The Cargill Company

Complete Printing Service

Grand Rapids, Michigan

HOOPES BRO. & DARLINGTON

(INCORPORATED)

WEST CHESTER, PA.

WE ARE MAKING

AUTOMOBILE WHEELS

Forty Years' Experience as WHEEL MAKERS is guarantee we can make good ones.
Will not make any other kind. Try them.

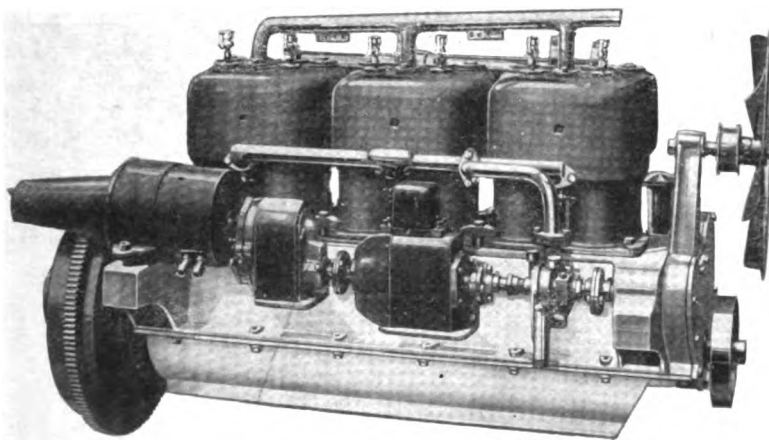

Model 6B Motor, 4½" bore by 5" stroke

Quality and Service

are the two essentials that for 17 years have been built into

BRENNAN STANDARD MOTORS

The manufacturer of Commercial or Pleasure cars who equips his product with Brennan Standard Motors can feel assured his every requirement regarding this vital part has been fulfilled.

Built in the following sizes:

- | | |
|---------------------------|----------------------------|
| 4 Cylinder Model M—4 x 5 | 4 Cylinder Model 12—5½ x 6 |
| 4 Cylinder Model B—4½ x 5 | 4 Cylinder Model 12—6 x 6 |
| 4 Cylinder Model 11—5 x 5 | 6 Cylinder Model 6B—4½ x 5 |

Let us send bulletins telling WHY Brennan Motors are STANDARD motors

Brennan Motor Mfg. Co., Syracuse, N. Y.

WILLEY'S COLORS

The Recognized Standard



C. A. WILLEY CO.

COLOR GRINDERS

and Manufacturers of Specialties in

CARRIAGE, AUTOMOBILE and CAR

PAINTS

COLORS, VARNISHES, ETC.

HUNTER'S POINT, NEW YORK CITY

The WEST Hydraulic Tire Setter

WILL CUT DOWN EXPENSE

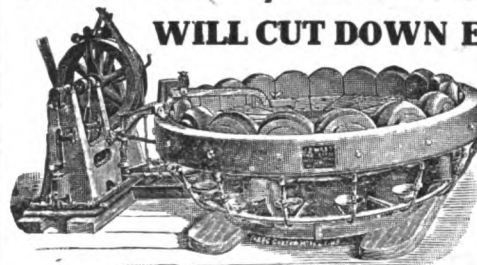

Tires set cold in one minute. This machine saves time—does the work better and quicker, does a way with burned streaks. Only necessary to measure one wheel in a lot. Does not char the rim, and

thus make the tire loosen prematurely. Saves resandpapering of wheels. This machine is now increasing the profits of many manufacturers. Send for catalog and read about it.

WEST TIRE SETTER CO., ROCHESTER, NEW YORK

THE FAIRFIELD RUBBER COMPANY

Manufacturers of

Carriage Cloth, Imitation Leather,

Automobile Cloths, etc.

FAIRFIELD,

CONNECTICUT

The Hub

Valentine's Painting Materials

Valentine's varnishes are the highest grade vehicle varnishes made—that is, the most brilliant, most easily used, and most durable.

Also, they are of necessity the most expensive; by using them the makers of all the best automobiles and carriages show that they pursue the

policy of equipping their products with the best materials, whatever their cost.

Owners of automobiles and carriages should ask for Valentine materials when having them re-finished. Any vehicle painter will use them if specified. Most painters use them regularly.

Write for our book, "The Care of the Car"

TRADE **VALENTINE'S** MARK.

Valentine & Company

Largest Manufacturers of High Grade Varnishes in the World

456 Fourth Ave., New York 343 S. Dearborn St., Chicago 74 Pearl St., Boston



PAT. MAY 27, 1909

"E-Z" Welding Compound is the best for general welding.

Because it sticks to the metal at a low heat.

Because it makes perfect welds at fully 250 degrees lower heat than any other.

Because it does not boil up and waste while fluxing.
Because it prevents slipping of laps.

CRESCENT
WELDING
COMPOUND
TRADE MARK

CRESCENT Welding Compound is the best substitute for borax known. It is particularly good for welding under dies and where parts are fastened together before welding, like Toe Calks, etc.

FOR SALE BY ALL JOBBERS
Samples Sent Free

Manufactured only by

ANTI-BORAX COMPOUND COMPANY, Fort Wayne, Ind.

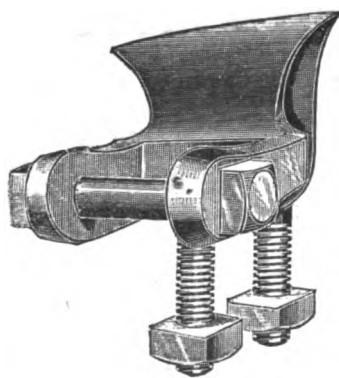

Skewed Shaft Couplings

Regular or Oval Patterns
For High Arched Axles

Furnished in rights and lefts for any height of arch.
Oval Axle Clips $\frac{5}{8}$ or $\frac{3}{4}$ width to match Oval Couplings. Bolts, Clips, Couplings, Carriage Hardware and Special Forgings

Catalogue "H" and Prices on Application

COLUMBUS BOLT WORKS COMPANY

COLUMBUS, OHIO

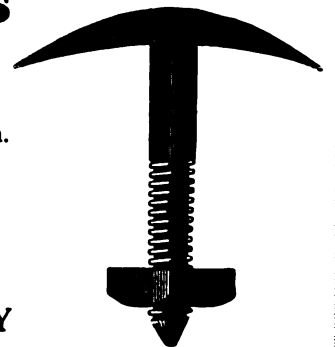

Ask the Man

Who Uses "F-S" Products

The beauty, durability and working qualities of our Coach, Carriage and Automobile Varnishes and Japans are apparently appreciated by numerous users. Their confidence is maintained by a policy that prevents any variation in the quality of the ingredients.

FELTON, SIBLEY & CO., Inc.

Manufacturers of
Colors, Paints and Varnishes since 1863

136-140 North Fourth Street
PHILADELPHIA

The Hub

First Journal of the Vehicle Industry

Vol. LVIII

NEW YORK, DECEMBER, 1916

No. 9

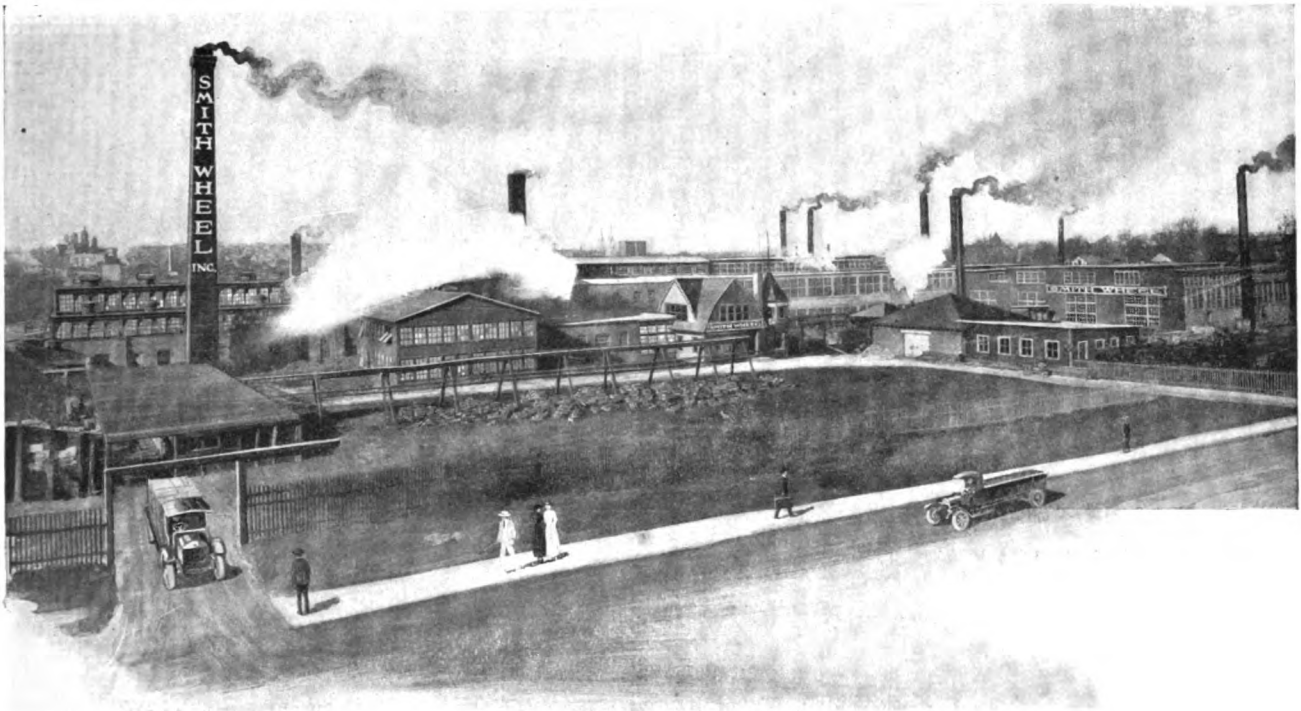

Home of the Smith Wheel



Tire Mileage Increased—Gasoline Mileage Increased—Truck Life Increased

Smith Wheels Guaranteed during LIFE OF TRUCK on which originally placed.

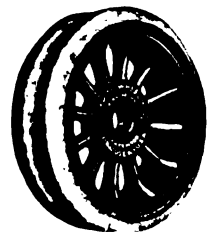

Smith Wheels Make Trucks More Saleable

Made for Trucks of any size and to fit any axle.



We will prosecute any manufacturer of a wheel of hollow spoke design, or of a type having a felloe with internal braces, for infringement of our Patent Rights.

Buy "Hickory Nut," "Acorn" Vehicle Wheels

You cannot buy better wheels dollar for dollar paid. A bad wheel is a big "Leak" in your business.

STOP THAT LEAK TODAY

By Asking Your Jobber for
WHEELS "MADE IN ST. MARYS"

Export Office: 8 Bridge St., NEW YORK CITY
Factories: ST. MARYS, O.; RICHMOND, VA.

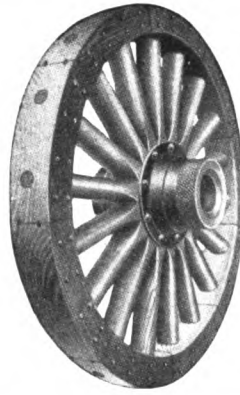

and "Star" Brand Carriage Woodstock

We make a specialty of Spokes, Hubs, Bent Hickory and Oak Rims, Poles, Shafts, Singletrees, etc., for **New Work or Repairs.**

Buy "Star" Brand and be a satisfied customer.

INSIST ON OUR BRANDS

St. Marys Wheel & Spoke Co.

Consolidated with CRANE & MacMAHON, Inc.

ST. MARYS, O. :: U. S. A.

steel stampings

especially for
COMMERCIAL TRUCKS

The Pressed Steel Co. of N. Y.
141 Broadway



SEAMLESS TUBING STEEL—BRASS—COPPER

**Send Us Your Specifications
for Rush Requirements**

MURCOTT-DUDEN CO., Inc.

253 Broadway

New York



85-87 ADAMS ST.
BROOKLYN, N.Y.

Felts for the Automobile and Machinery Trades a Specialty

DUST RINGS FOR HUBS STRIPS FOR CRANK CASES
FELT WASHERS AND GASKETS FOR ALL LU-
BRICATING AND DUST EXCLUDING PURPOSES

No order too small to receive prompt and most careful attention

WILCOX

**FINE
FINISHED
FORGED**

**CARRIAGE HARDWARE
AND GEAR IRONS**

Write for Prices and Catalog

The D. Wilcox Mfg. Co.

MECHANICSBURG, PA.

A sure way to reduce your costs!

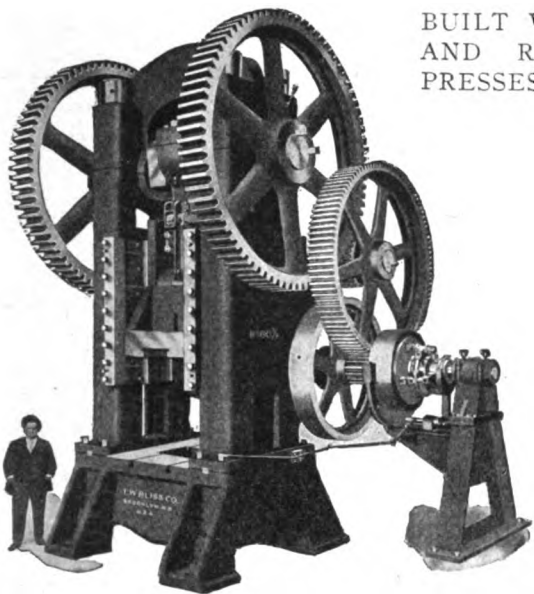

BUILT WITH THE GREATEST POSSIBLE STRENGTH AND RIGIDITY, BLISS STRAIGHT-SIDE POWER PRESSES MINIMIZE THE MAINTENANCE COST OF BOTH MACHINE AND TOOLS.

Bliss Straight-Side POWER PRESSES

are being widely used for heavy punching, piercing, shaping, stamping and drawing operations in the manufacture of automobile parts, agricultural implements, electrical instruments, cutlery and heavy hardware. They are also adapted for trimming drop forgings, hot or cold.

Built in various sizes ranging in weight from 5,000 to 175,000 pounds.

We are anxious to send you full details.

Let us know your requirements and we'll be glad to offer you a few valuable suggestions. Write us at once.

"Bliss" No. 80 1/2 Straight Side Press
Weight, 175,000 Pounds

E. W. BLISS CO.

38 ADAMS STREET

BROOKLYN, N. Y., U. S. A.

Chicago Office: 622 West Washington Boulevard
Detroit Office: Dime Bank Building

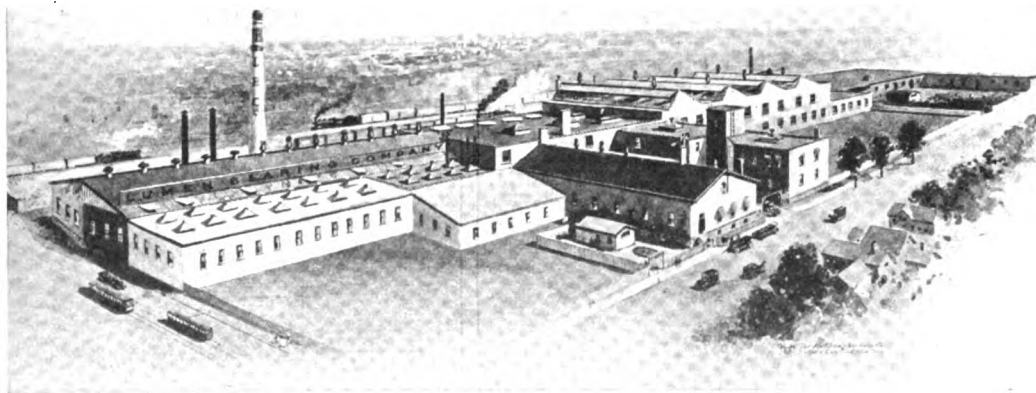

THIS COMPANY WILL EXHIBIT A COMPLETE LINE OF BRASS AND BRONZE CASTINGS AS MANUFACTURED FOR THE AUTOMOBILE TRADE IN SPACES C-69 AND 70 AT NEW YORK AUTOMOBILE SHOW, AND IN SPACES 6 AND 7 COLISEUM GALLERY, CHICAGO AUTOMOBILE SHOW

LUMEN BEARING COMPANY
BRASS FOUNDERS
BUFFALO

Keratol

**A Combination for Co-operation
Not Restraint of Trade**

Two of the largest and most important factors in the manufacturing of automobile fabrics have combined in the supplying of a material of superior quality:

The Wm. L. Barrell Company, a long established cotton house with a traditional reputation for the quality of the fabrics which they have been furnishing to the automobile trade,—

The Keratol Company, originators and pioneers in the making of Keratol, for which split leather is an inferior substitute,—

The combined resources of these firms and their affiliations make for an efficiency in the production and distribution of Keratol which no automobile or vehicle manufacturer can afford to overlook.

Inquiries should be directed to the Wm. L. Barrell Company.

The Keratol Company
Newark, N. J.

WM L. BARRELL CO
8 Thomas St. ————— New York

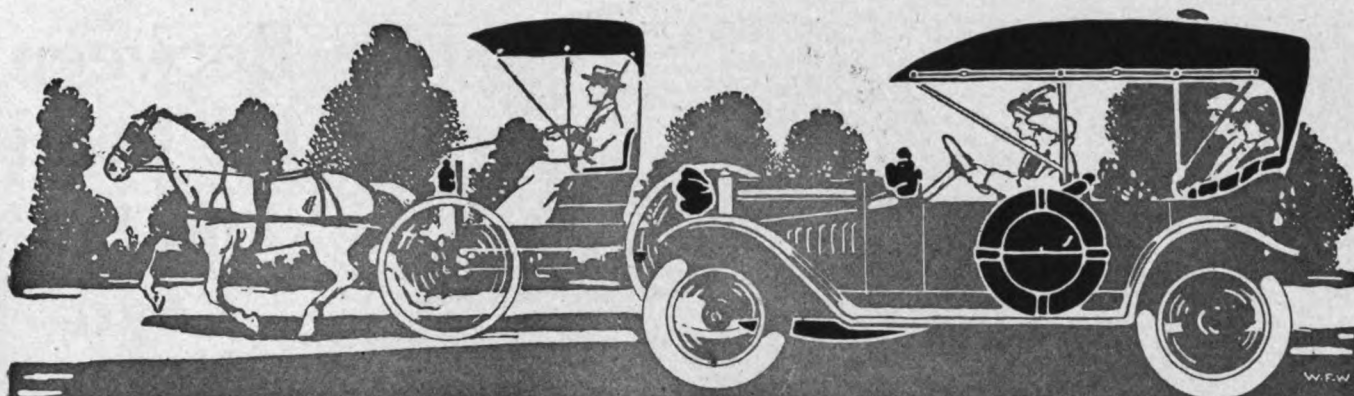

The Leading Leather Substitute For Carriage and Auto Trade

When you need a leather substitute, join the other progressive carriage and automobile manufacturers and select the leading leather substitute—

MERITAS

LEATHER CLOTH

A leather substitute is but a substitute after all—but Meritas leather cloth is made and finished to withstand the hardest wear and handling.

Meritas Leather Cloth is durable, of non-cracking finish and guaranteed perfect by our trademark stamped on the back of every yard. You will like the selection of colors and the lasting finish of this serviceable leather substitute.

Meritas Leather Cloth is made in muslin, duck and drill; dull or glazed; smooth or grained; in black and colors.

Learn more about this leading leather substitute by writing for sample book—sent on request.

Write
for
sample
book of
MERITAS
LEATHER CLOTH
NOW

The Standard Oil Cloth Co., Inc.

320 Broadway, New York

Between the Load and the Road

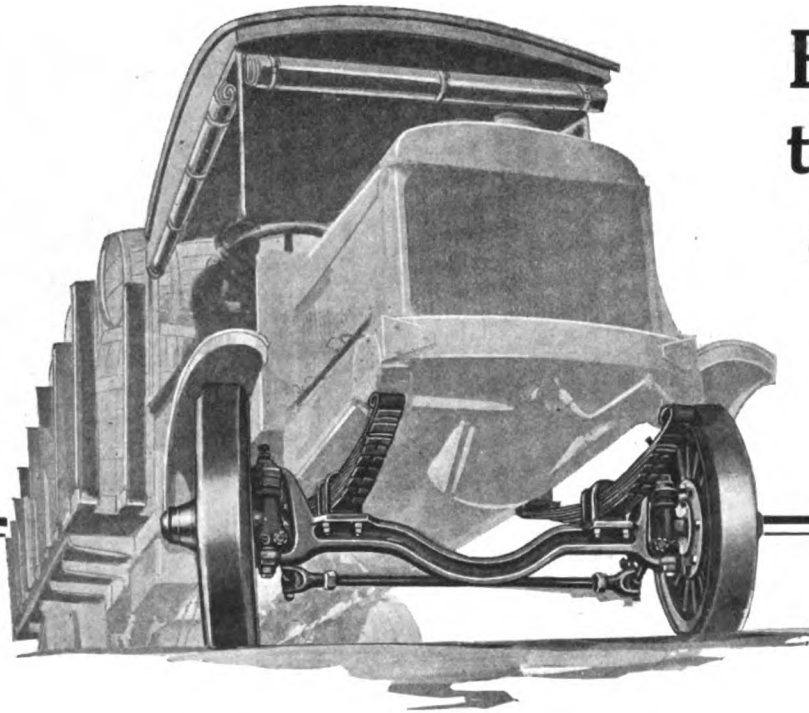

are the Axles and Springs, the parts that determine whether the truck is going to "get there" with its load, and how much it's going to cost to do it.

Do you realize, Mr. Truck Buyer, that these three factors

1. How steadily a truck runs,
 2. How much it costs to keep it in condition to give continuous service, and
 3. How little it depreciates in performing this service,
- are what really determine the value of the truck. Purchase price, often the deciding factor in the choice of a truck, is not a reliable guide. Usually the cheapest truck to buy is the most expensive to maintain—the hardest to keep in operation—the quickest to depreciate.

SHELDON

SHELDON Axles and Springs are the highest priced on the market, hence SHELDON-equipped trucks generally bring a higher price than trucks equipped with other makes of Axles and Springs. But SHELDON-equipped trucks are CHEAPER IN THE END because the extra money represents value, and value in Motor Trucks means low upkeep, constant operation, and little depreciation.

Hadn't you better learn all about it? We'll be glad to send full particulars and give you a list of SHELDON-equipped trucks on request.

Sheldon
Axle
&
Spring
Company

Wilkes-Barre,
Penna.

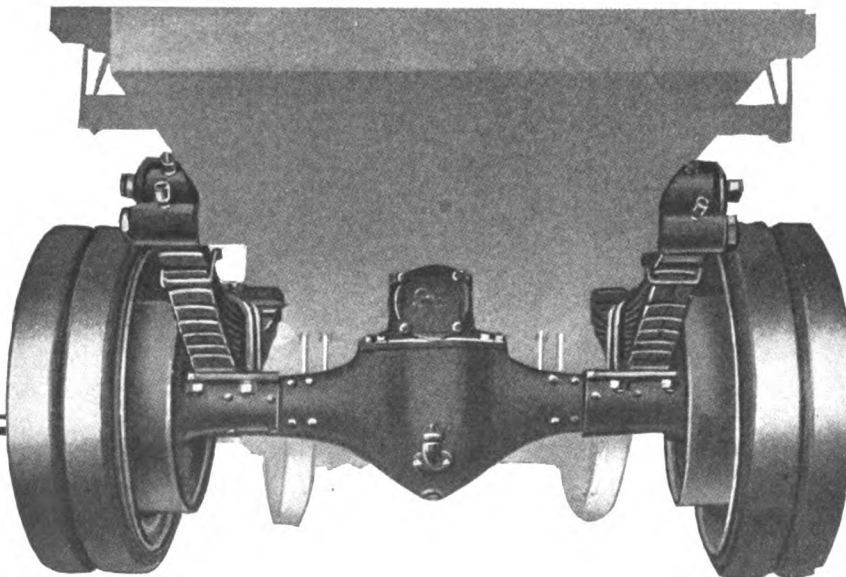

Please mention "The Hub" when you write

The Pike's Peak Record

Boston and Other Hard Ones

Both Ads from Collier's Sept. 30, 1916

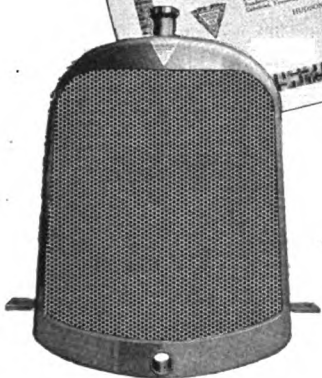

It is significant that such records in Hill Climbing are made by cars equipped with the

HARRISON

Original Hexagon

CELLULAR RADIATOR

It is also significant that 80 per cent of radiation now used is of the hexagon type. You can identify the original by the horizontal arrangement of the cells—the design that gives greater cooling capacity with less weight.

Watch the Harrison this year on cars like the
CHANDLER — HUDSON — HUPMOBILE — MITCHELL
 also **GRAMM and FEDERAL TRUCKS**

Book of Radiator Design and Efficiency on request

THE HARRISON MFG. CO., Inc.
LOCKPORT, N. Y.

Please mention "The Hub" when you write

DROP-FORGING PROGRESS REFLECTS

Crystallized Thought

Specialized Study

Vitalized Achievement

Dependable
Drop-Forged Parts

Lever
Clevis
Tappet
Rocker
Special Rod and
Yoke Ends

Parts for
Starters
Lighters
Electrical Devices
Shock Absorbers
Accessories

If you want early delivery,
send us your specifications for
small and medium sized drop-
forgings

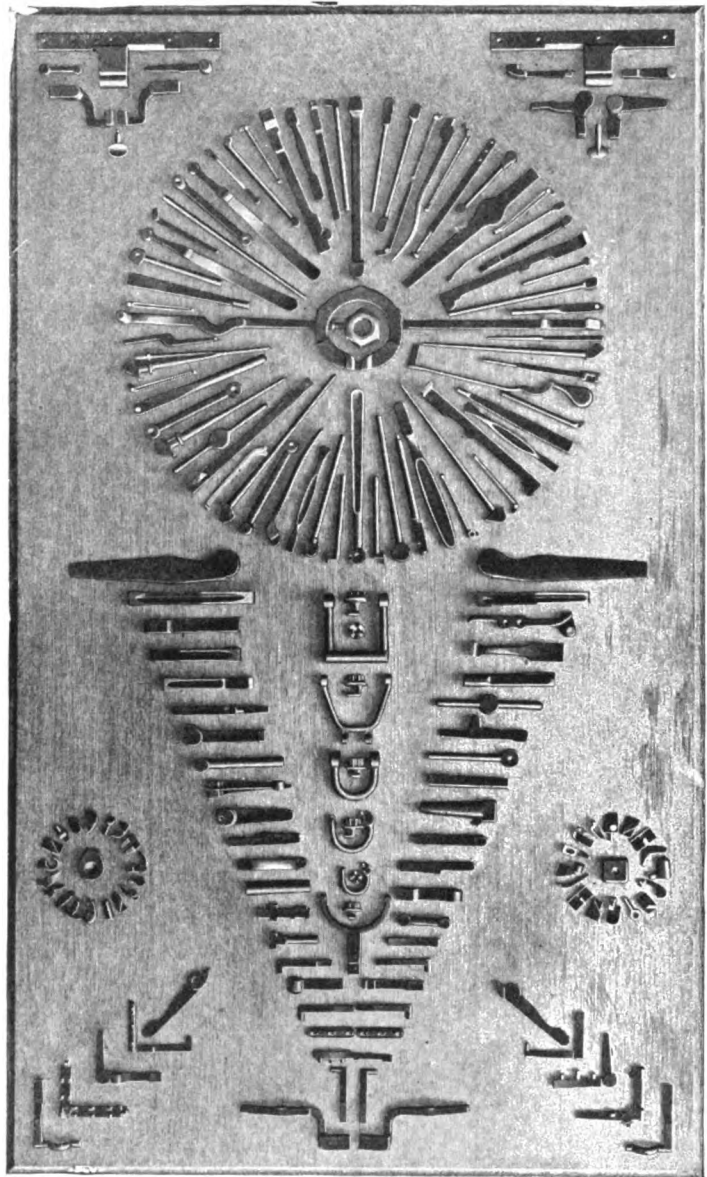

A few of Williams' Superior Drop-Forgings,
Winners of the P. P. I. E. "Grand Prize" for Special Drop-Forgings

Its "standard bearers" anticipated exacting requirements and measured their product in terms of quality alone. Time and experience have confirmed their judgment. Only in rare cases now can weaker substitutes be used in place of

"Superior Drop-Forgings"

We specialize in the careful forging and proper heat treating of all alloy materials. We possess the necessary facilities and experience in chemical and physical laboratories to develop the maximum in strength and durability with the minimum of size, weight and form.

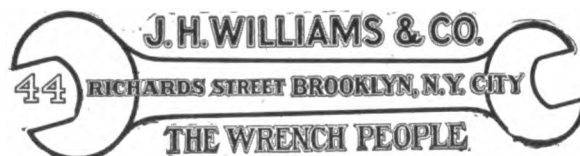

Please mention "The Hub" when you write

The Hub

Vol. LVIII

NEW YORK, DECEMBER, 1916

No. 9

Published Monthly by

THE TRADE NEWS PUBLISHING CO. OF N. Y.

PAUL MORSE RICHARDS, *President* G. A. TANNER, *Secretary and Treasurer*
EDISON BUILDING, COR. ELM AND DUANE STS., NEW YORK

THE HUB, a monthly authoritative journal on all subjects pertaining to the vehicle industry from its engineering and construction viewpoints. It publishes information of live interest to manufacturers of motor vehicles, trailers, carriages, wagons, the accessory trades, repair shops and garages.

Subscription price for the United States, Mexico, Cuba, Porto Rico, Guam, the Philippines, and the Hawaiian Islands, \$2.00; Canada, \$2.50; payable strictly in advance. Single copies, 25 cents. Remittances at risk of subscriber, unless by registered letter, or by draft, check, express or post-office order, payable to the order of THE TRADE NEWS PUBLISHING CO.

For advertising rates apply to the publishers. Advertisements must be acceptable to publishers. Copy for new advertisements must be received by the 25th of the preceding month. All communications must be accompanied by the full name and address of writer.

Entered in the New York Post Office as Second-class Matter

The Labor Situation

The labor situation has been inevitably strained by the rise of living costs. The steel and textile industries, two of the greatest employers of labor in the country, have granted a 10 per cent increase in wages for the third time since January 1, 1916, and wage advances are general. Employers admit both the justice and necessity of this policy. They are prosperous, willing to pay more, and eager to work their plants to capacity. The situation is interesting from an economic standpoint as showing the inevitable reaction upon wages when capital is prosperous, but there is no little anxiety as to what the attitude of the wage-earners will be if conditions after the war will not allow the payment of such wages.

The controversy between the railway companies and the trainmen has been revived by the action of the companies in bringing suit to obtain a judicial interpretation of the Adamson act. In a case brought before Judge Hook, of the United States Circuit Court, at Kansas City, he gave what he admitted to be a hurried opinion, in order that the case might be expedited to the Supreme Court, holding that the law was unconstitutional. The case will be argued at once before the Supreme Court, and it is expected that a decision will be obtained before January 1, when the law, by its terms, is to take effect. If it should be found invalid, the situation will be what it was before the law was hastily passed under the threat of an immediate strike, except that there has been an opportunity since then to take the opinion of the country upon it. There can be little doubt that the judgment of the country has been unfavorable. In the long run the interests of

the public, rather than the interests of either railway owners or railway employes, are bound to determine the conditions upon which the railways shall be operated.

It is quite possible that the companies and men may get together upon a settlement while the case is pending, and if not, it is probable that the President's recommendation for a law similar to the Canadian arbitration act, which forbids a strike upon railways until a government inquiry has been held, will be carried out. In asserting a right to tie up the commerce of the country by concerted action the trainmen have been led to take a position that cannot be sustained. The difference between an individual's right of action and the right of combination is the basis of all the anti-trust legislation.

Looking After Our Foreign Trade

The new Federal Trade Commission has been going further into American export business as related to that of Europe after the war. It takes a common-sense view in expecting that Europe's industrial recovery will be slow. Time will be required to gather the capital and material needed to repair the wastage, and thereafter will be the handicap of higher taxes and higher wages.

But there will remain for us to deal with the old European advantages of large investments in neutral markets, extensive bank facilities, steamship connections and export associations.

We are developing with extraordinary rapidity all these factors for foreign trade except the last. The bars which were up against them have been let down. But there is still some doubt about the legal right of small producers to act together exclusively for export purposes, which would enable them to stand up not only against the single great exporting concerns at home but exporting combinations abroad. This doubt, concludes the commission, should be removed.

It is the business of the Federal Trade Commission to look into and look after such matters, and it is testifying to its usefulness in this particular matter. Congress can much more safely grant such a power to restrain trade at home than it could without the commission. A bill to this effect was up at the last session. It should find enactment now.

Huge Foreign Commerce

The foreign commerce of the United States in the calendar year 1916 will approximate \$8,000,000,000, or one-fifth of the international trade of the world. It will be 50 per cent greater than that in 1915 and double that of 1914. A compilation by the Foreign Trade Department of the National City Bank of New York shows that the total for-

ign trade of the year, which ends with this month, seems likely to approximate \$8,000,000,000 against \$5,326,000,000 in 1915 and \$3,903,000,000 in 1914. The excess of exports over imports in 1916 will approximate \$3,000,000,000 against \$1,768,884,000 in 1915, \$324,348,000 in 1914 and \$691,422,000 in 1913.

Car Shortage

The American Railway Association announced that on November 1 there was a shortage of 108,010 cars on the railroads of the United States. This is the largest shortage ever recorded and its growth has been rapid since September 1, when it was only 19,873 cars. The railroads own about 2,450,000 freight cars. The supply was more than sufficient until August to meet all demands.

Shippers and receivers of freight should see to it that their cars are released as promptly as possible in order that they may be put to the fullest use and the danger of congestion minimized.

War Prosperity

The warring countries of Europe, according to the Federal Reserve Board, have paid the United States more than \$7,000,000,000 since the war began.

The disbursement of this enormous sum indicates the source of the prosperity which is felt from one end of the country to the other. Payments of this kind will cease almost entirely when the war ends. Far-sighted American manufacturers are already preparing for the time when the golden torrent will be cut off and they will be compelled to fall back to normal conditions.

Sale of Munitions

The allied governments bought from American firms during last September, firearms and munitions to the amount of \$117,500 for every hour of the day and night. The total was more than \$84,500,000. The exports included cartridges, value, \$5,788,653; gunpowder, value, \$34,886,942; all other explosives, \$34,615,989; firearms, value, \$9,259,253.

National Bank Resources

The resources of the national banks on September 12 were \$14,411,000,000, which was \$216,000,000 greater than they had ever been in the history of the country. The deposits amounted to \$11,362,000,000, or \$227,000,000 greater than they had ever been before.

Favors Absolute Limit on Wheel Loads

Nelson P. Lewis, chief engineer of the Board of Estimate and Apportionment, New York, in speaking before the annual meeting of the American Road Builders' Association at the Automobile Club of America, in November, regarding the growing congestion of traffic owing to the increasing width and capacity of motor vehicles, favored the imposition of an absolute limit upon wheel loads and dimensions in order to preserve the highways both in the city and country. The only effective remedy, he said, appeared to be the enactment of drastic ordinances and laws that will absolutely prohibit the use of vehicles having more than a specific load per inch width of tire. That load should probably be less for steel tires than for rubber tires. The width and length of such vehicles was also a matter of serious concern, especially on city streets. It

is believed that if the increase in width is allowed to proceed, costly street widenings will become necessary. The capacity of the roadway was of course decreased, owing to the width of vehicles. Mr. Lewis stated that the Pennsylvania Legislature in 1913 had passed a law prohibiting the registration of motor vehicles exceeding 90 in. total width and carrying loads in excess of 24,000 lbs. for vehicle and load combined. The gross load on any axle was limited to 18,000 lbs., or 750 lbs. per inch nominal width of solid tire.

In closing he gave some interesting figures regarding the load carrying capacity of trucks now being manufactured. Of 221 manufacturers producing commercial vehicles at the beginning of the present year, 133 confined themselves to those of less than three tons' capacity. Of the 88 manufacturers offering trucks of more than three tons capacity, 12 appear to have increased this capacity in their models for this year, only two of these increases being to six tons; six makers have decreased the capacity of their trucks, one from 4 to 3½ tons, three from 5 to 3½ tons; one from 6 to 4 tons, and one from 7½ to 5 tons. Of 12 newcomers in the field only one offers a truck with a capacity of 6 tons and two of 5 tons, while the rest provide for smaller loads.

Description of Fashion Plates

Products of Studebaker Custom Department

The two illustrations on page 11, as well as the one on the top of page 12 represent special jobs turned out by the custom department of the Studebaker Corporation. These models are supplied on the six-cylinder chassis only and are furnished in several different colors, viz., cadet blue, azure blue, carmine, maroon, purple lake, battleship gray natural gray and Brewster green.

These jobs are well appointed in all respects, equipped with special grade silk mohair tops, with the exception of the Victoria top, which is made of leather, and the windshields on all are nickel plated.

Delivery Wagon

The illustration on the bottom of page 12 represents a delivery wagon built by the Trenton (N. J.) Body Co. The body is mounted on a Ford chassis. It has built-in windshield which breaks outward at any angle. The curtains are vertical and roll toward driver's seat, and fasten. Remove the fasteners and they roll forward.

A Combination for Co-operation

The advertising pages of this issue of *The Hub* contain a story of unusual interest to the trade. It is the announcement of a combination of two of the large and important factors in the manufacture of automobile fabrics.

The Wm. L. Barrell Co., of New York City, well known for the excellent quality of the fabrics which it has been supplying the automobile trade, has combined with the Keratol Company, of Newark, N. J., the makers of Keratol, "for which split leather is an inferior substitute," as that company uniquely puts it.

This combination in the production and distribution of Keratol should make for an efficiency which no automobile or vehicle manufacturer can well overlook.

The population of the United States gained only 169,061 from immigration during the last fiscal year. This is the smallest increase during 18 years.

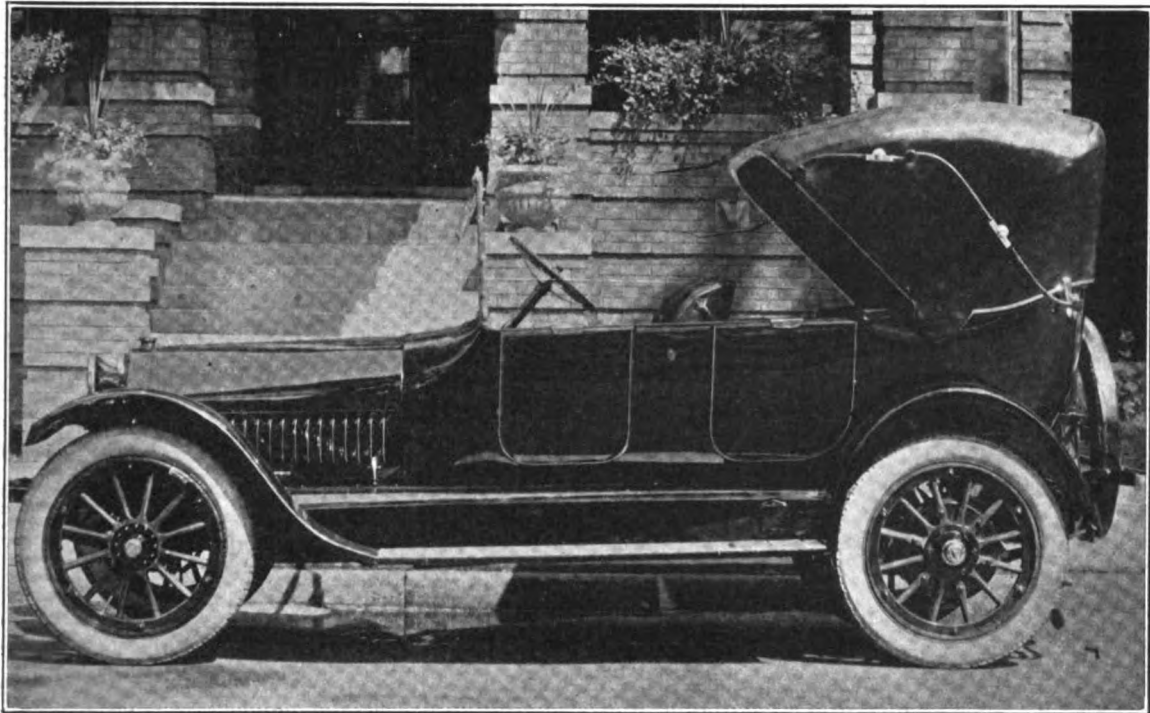

PRODUCT OF THE STUDEBAKER CUSTOM DEPARTMENT

See Page 10

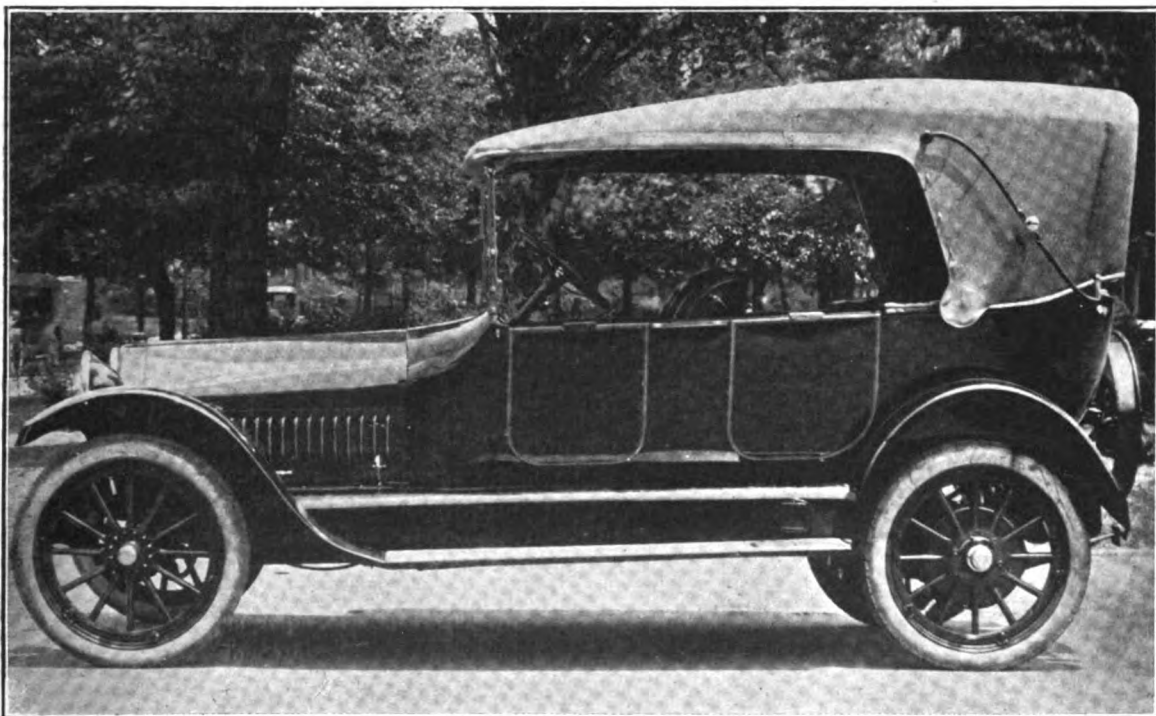

PRODUCT OF THE STUDEBAKER CUSTOM DEPARTMENT

See Page 10

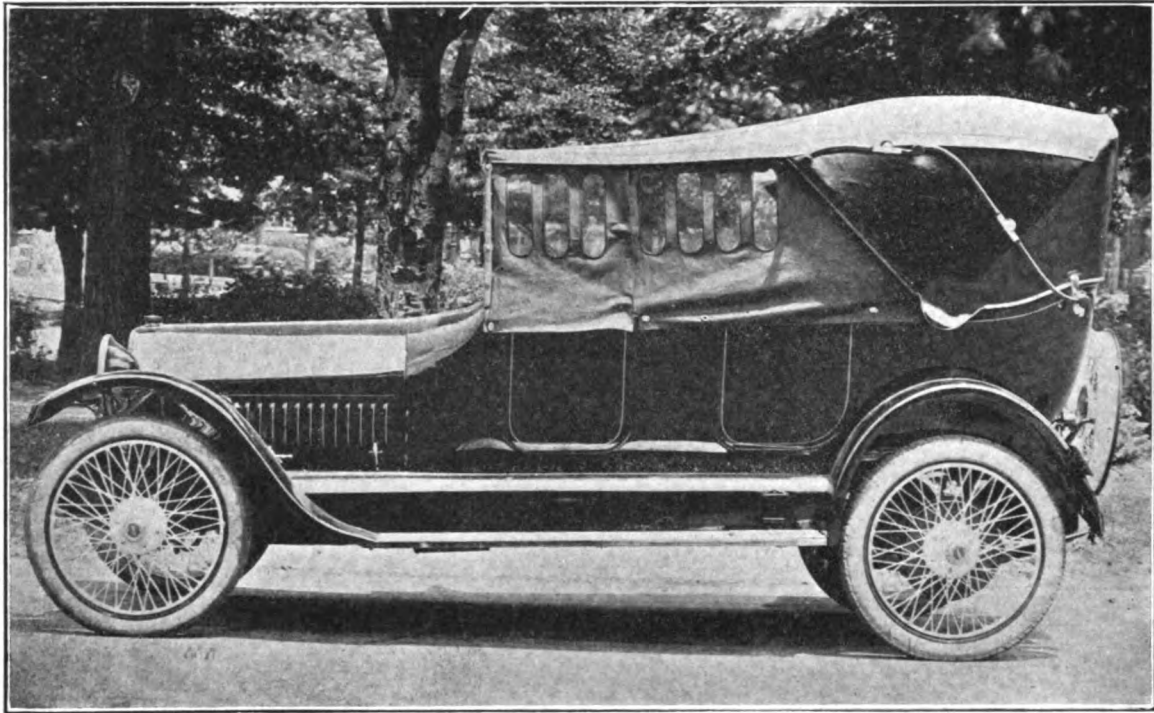

PRODUCT OF THE STUDEBAKER CUSTOM DEPARTMENT
See Page 10



DELIVERY WAGON
Built by Trenton (N. J.) Body Co.
See Page 10

Production Methods Adapted to Shop With Small Output

How a Buggy Plant Was Transformed Into an Automobile Works With Small Outlay

That it is possible to build good cars in out-of-the-way places and that it is not only possible but highly profitable to apply to production in small quantities certain of the methods that have been developed and heretofore employed almost wholly where very large production is involved is indicated in a contributed article to *Automobile Topics*. The writer says:

The experience on which these statements are based was gained in an isolated community which might be either north, east, south or west of Detroit, but actually is removed from the center of automobile industry in neither of those directions. For many years a leading industry of that community has been the building of buggies, but with the coming of the motor vehicle, buggy sales languished as did the business, so that in due course the eventful decision was reached to convert the plant into the production of motor cars. As to the precise details of the plan that was achieved and the nature of the car that was evolved detailed explanations are needless. It is sufficient here to indicate that the car is a good one in its class, by no means low in price; and that it is produced, just now, at a rate of not over 200 jobs a year.

Production in this plant at first was like production in any one of the numerous plants of the same general character that dot the country here and there. A few parts were purchased, a few mechanics, long in the employ of the concern, set at work putting them together, "haphazardlike," and occasionally a car would emerge. System there was none. Uniformity was lacking. Results were uncertain.

Throughout the territory that had long been supplied with buggies, however, were numerous agents who had been tuned up to handle the company's cars. Customers they had in satisfactory numbers, there was abundant good will for the business, and means to carry it through. Early results, however, were not altogether pleasing in some respects and so a retainer was found for the consulting engineer.

A preliminary survey of the situation revealed two things: a grand little opportunity and splendid means to fulfill it. The opportunity consisted of the general situation just outlined. The means consisted of a very good design on the order of the assembled car, embodying well-selected and well-balanced components, nearly all of which were of well known and standard make.

The problem presented to the engineer was to find means for putting the cars together in an economical way and insuring their production with a fair degree of regularity and uniformity. Similar undertakings in the past have not proved wholly satisfactory to the consultant in every case. Better success here may have been due to more favorable surroundings, or it may have been due to the employment of "regular" production plans.

By way of plant, the company was provided with a main building, four stories high, something over 200 feet in length and approximately 50 feet in width. It was practically barren of equipment, and it is an interesting fact that such as was ultimately provided, and is now in use, cost little more than \$1,000 and was largely fabricated on the spot.

The general scheme of production adopted was the now

familiar progressive assembly, barring, of course, the cable system, that is needful where large production is involved. All chassis work was centralized on the ground floor, the upper floors being set aside for body assembly and for painting. The only change in the building was the cutting of a large hatchway in the second floor at a point near the end of the assembling line.

As at present worked the little, slow-moving, progressive system begins with the framing of the bodies on the top floor, the frames receiving the metal sheathing and being rubbed down before going to the floor below. There they are leaded, painted, rubbed and varnished, all except the final coat, before proceeding to the second floor, where they receive the upholstery and all equipment.

The upholstery is completed in separate units, ready for attachment and final mounting in the car, and the complete equipment is put in the bodies before they go downstairs, up to and including all trimmings and fittings, the tools and the numerous incidentals that help to make the car attractive to its rural purchasers, over and above the attractions of some of the offerings of the larger markets. When ready for the chassis, therefore, the body is entirely complete save for attachment.

Chassis assembling, on the other hand, begins with the sub-assembling of three units, namely, the front and rear groups, consisting of wheels, axles and springs and the frames, with fenders and running boards attached. Upon passing the assembly, which includes a "running-in" test for the gears, these groups are carried to the painting floor above, where they are finished in color up to and including every operation except the final varnish coat. They are then returned to the ground floor for final assembly.

Considering the nature of the car it is perhaps needless to explain that a unit power plant is used, or that it arrives at the "factory" in completely assembled form, barring the electrical equipment. Upon arrival at the factory each power plant is taken to the "dynamometer room" for its running-in and economy tests.

The dynamometer equipment is simple, consisting merely of a double-bladed fan, mounted in heavy supports at the rear of the engine cradle. A speedometer, permanently installed on the wall, serves to give the speed readings by connection with the permanent speedometer drive in the gear box. As for power readings, there are none. The tester simply has instructions to see that each engine is capable of making "50 miles an hour" by the speedometer on the power test; and that it will run a quart of gasoline at "15 miles an hour" in not more than 11 minutes on the economy test.

While being operated in this manner, each engine is thoroughly gone over with the stethoscope for hidden noises, excepting only such as come from the tappets. At the end of the economy test, when the tappets have had a chance to become partly bedded-in, a final adjustment of the lifts is made.

In further explanation of the dynamometer system, it may be added that occasional calibrations are made by means of a simple prony brake. Experience has proved, however, that such variations in the fan load as occur, are not sufficiently great to destroy the practical value of the routine. The beauty of the system, of course, is that it was practically all constructed on the job and therefore cost little more than the time of the mechanics that produced it, lumber and labor being scandalously cheap in the vicinity of the plant.

Carried over to the assembling line in the main building, the power plant is dropped into the chassis, which by this time has received its steering gear and radiator and is therefore ready for the engine. As soon as the propeller shaft has been hooked up, the chassis under the open hatchway and the body lowered from above—one man handling the trolley and hoist—attached, and the hood fitted. Up to this point the chassis has been conveyed on castors. At this point, however, it is pushed over inclined planes in the floor which serve to lift it, permitting it to be rolled away on its own wheels. After being finally inspected and given a short test run, the car is taken to a special varnishing room for its final flowing coat of gloss.

In all this, there is employed only the native labor that has long been employed in the carriage work. Ingenious blacksmiths and millwrights are to be found at any such plants, so that there was little difficulty in carrying out the engineer's ideas as to shop equipment needs. Labor and lumber are plentiful and cheap. Fitting up for the work, therefore, involved astonishingly little difficulty.

As for the carrying out of the engineer's ideas in "production," there was likewise little difficulty in establishing the routine. The older mechanics took readily to the notion of piecework, and were promptly given contracts for assembly units, and permitted to hire their own helpers. Once the ball got rolling, it rolled very nicely.

True, other things might be told as to the difficulties of maintaining routine in a shop where routine had never been known; of the difficulty of enforcing standards of workmanship in an organization too small to maintain a regularly constituted inspection department. But that is another story. One incident may indicate how possibilities of building good cars under such circumstances as have been outlined may be snagged by small matters.

The engineer, returning after an absence, was shown a series of letters of complaint from a dealer who had just received his first carload—three cars. They had arrived, it seemed, minus certain minor accessories, that the sales manager had decided "would never be missed." The accessories not having reached the plant when the cars were otherwise in readiness, he had merely taken a chance. Unfortunately, however, the printed matter described all the equipment in most minute detail, and the purchasers had been reading the printed matter thoroughly. What it cost in telegrams and expressage to straighten out the tangle would have equipped about a dozen cars with that particular doodad.

These and other difficulties may be described as organization troubles, however. They have nothing whatever to do with the possibilities of building good cars cheaply under such circumstances. That has been affirmatively shown, in physical experience, if not in its narration heretofore. The point to which attention has not been sufficiently directed up to this time is that the small assembler of cars, doing largely a local business, can, if he knows how, build them so cheaply as to become a very live competitor for the big maker, whose offerings must be set back by heavy freight charges.

Will Declare Wage Dividend

Beginning January 1, 1917, whenever the Doehler Die-Casting Co., of Brooklyn, N. Y., and Toledo, O., declares the regular dividend on its stock it will also declare a wage dividend amounting to 10 per cent per annum to all employes based on all wages actually received including

piece work and overtime. This wage dividend is subject to the following conditions:

An employe must be in the employ of the company without interruption for a full year before he can participate in the wage dividend. Upon completion of a full year's employment he automatically becomes a candidate for this wage dividend. His wage dividend will be calculated from the date of completing the first year's employment to the date of declaration of dividend.

This wage dividend when declared will be applied as follows: Will be paid in full to all employes who have been in the company's employ for a full period of three years or more. Two-thirds will be paid to all employes who have been employed for a full period of two years and less than three years. One-third will be paid to all employes who have been employed for a full period of one year and less than two. This wage dividend will be declared quarterly same as the stock dividend.

It is further announced that beginning January 1, 1917, all employes who have been working on the basis of 50 hours per week, will be put on a basis of 48 hours per week at the same pay, believing, as Mr. Doehler said, that eight hours per day was sufficient for all men who work. This company employs 1,200 men, and has a weekly payroll of approximately \$25,000.

Heavy Production of Benzol and Toluol

The present output of benzol and toluol in the United States is conservatively estimated at 3,500,000 gal. per month or 42,000,000 gal. per years. Of this total 3,000,000 gal. each month is benzol. When the new by-product ovens still under construction are completed the yearly output will easily exceed 50,000,000 gal. per year. Before the war this output was inconsequential in comparison.

STATEMENT OF THE OWNERSHIP, MANAGEMENT, ETC., REQUIRED BY THE ACT OF CONGRESS OF AUGUST 24, 1912, OF THE HUB, published monthly at New York, N. Y., for October 1, 1916.

State of New York,
County of New York, ss.

Before me, a Notary Public in and for the state and county aforesaid, personally appeared G. A. Tanner, who, having been duly sworn according to law, deposes and says that he is the Business Manager of The Hub, and that the following is, to the best of his knowledge and belief, a true statement of the ownership, management, etc., of the aforesaid publication for the date shown in the above caption, required by the Act of August 24, 1912, embodied in section 443, Postal Laws and Regulations, to wit:

1. That the names and addresses of the publisher, editor, managing editor, and business manager are:
Publisher, Trade News Publishing Co., 25 Elm St., New York, N. Y.
Editor, G. A. Tanner, 25 Elm St., New York, N. Y.
Managing Editor, none.

Business Manager, G. A. Tanner, 25 Elm St., New York, N. Y.
2. That the owners are: (Give names and addresses of individual owners, or, if a corporation, give its name and the names and addresses of stockholders owning or holding 1 per cent or more of the total amount of stock.)
Trade News Publishing Co., 25 Elm St., New York City,
Joseph H. Wright, Tom's River, N. J.
G. A. Tanner, 25 Elm St., New York, N. Y.
Geo. W. Hills, Fairfield, Conn.

3. That the known bondholders, mortgagees, and other security holders owning or holding 1 per cent or more of total amount of bonds, mortgages, or other securities are: None.

4. That the two paragraphs next above, giving the names of the owners, stockholders, and security holders, if any, contain not only the list of stockholders and security holders as they appear upon the books of the company but also, in cases where the stockholder or security holder appears upon the books of the company as trustee or in any other fiduciary relation, the name of the person or corporation for whom such trustee is acting, is given; also that the said two paragraphs contain statements embracing affiant's full knowledge and belief as to the circumstances and conditions under which stockholders and security holders who do not appear upon the books of the company as trustees, hold stock and securities in a capacity other than that of a bona fide owner; and this affiant has no reason to believe that any other person, association, or corporation has any interest direct or indirect in the said stock, bonds, or other securities than as so stated by him.

G. A. TANNER, Business Manager.

Sworn to and subscribed before me this 4th day of October, 1916.
(SEAL) JOSEPH R. FRITH,

Notary Public, New York County.
(My commission expires March 30, 1918.)

Electric Ovens in an Automobile Plant*

New Type with Conveyer Equipment at Willys-Overland Plant for Baking Enamels—Some of the Steam-Heated Ovens

One of the recent innovations in the manufacturing methods in the automobile industry is the use of electric ovens for drying or baking enameled parts. Electrically heated ovens in smaller sizes are also now being used in some other manufacturing plants. The first installation of electric ovens for drying enameled automobile parts was made, it is believed, by the Willys-Overland Co., Toledo, O., something over a year ago. This company has recently installed a large number of additional ovens and at present there are 52 electric ovens in the Overland plant. These are in various sizes, depending upon the material they are

ovens in a somewhat different manner, conveyors being used to take a load of small parts into the oven where they remain stationary until the baking operation is completed, when the conveyor carries them out the opposite side of the oven. This conveyor type of oven is particularly interesting from an economical standpoint in that it is found to effect a great saving in time and labor and to increase greatly the oven capacity.

The Willys-Overland installation of conveyor type of electric ovens include a battery of ten ovens 21 ft. 6 in. wide, divided in two compartments, 21 ft. 4 in. deep and

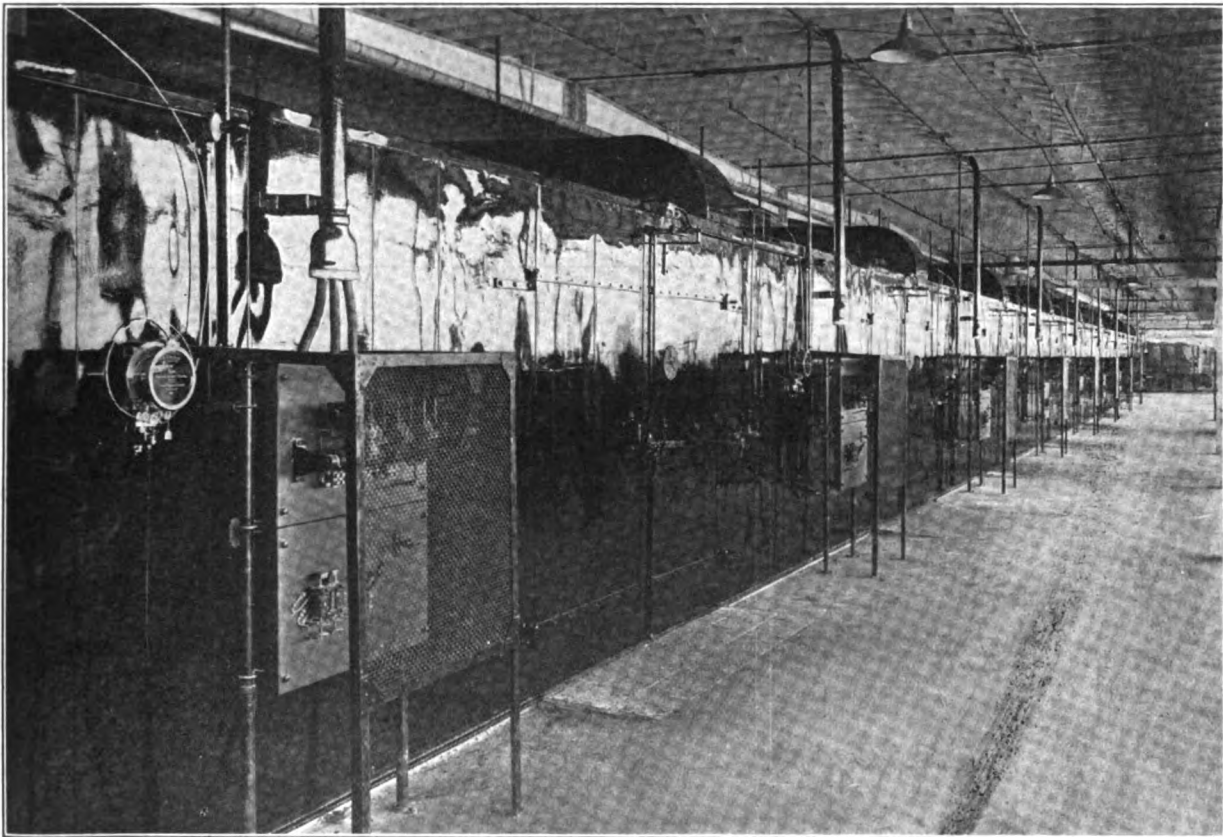

One of the batteries of electric ovens, these for baking car bodies. Local switchboards and temperature control apparatus are provided as indicated

to handle. They take no less than 7,000 to 8,000 kw. of electric energy.

Among the new oven installations at the Willys-Overland plant is a battery of conveyor ovens of a new type. Continuous open-end steam-heated ovens of the conveyor type and with long heating chambers, in which the frames and chasses are dried during progressive assembling while being carried very slowly on conveyors through the ovens, are now used quite generally in the automobile industry. The conveyor system is now being applied to electric

8 ft. in height. These are used for fenders, dust-pans, hoods and various other parts and have a capacity for drying the parts of 1,000 cars per day. Under the method generally followed, the parts are dipped and then are carried into the oven one by one. That method makes it necessary for the oven to cool off sufficiently for the workmen to go inside with the parts and from 40 to 60 minutes is lost in bringing up the heat after the oven is filled, to say nothing of the time required in carrying the individual parts into and out of the oven.

Under the new method with the ovens equipped with

*This article and illustrations reproduced through the courtesy of *The Iron Age*.

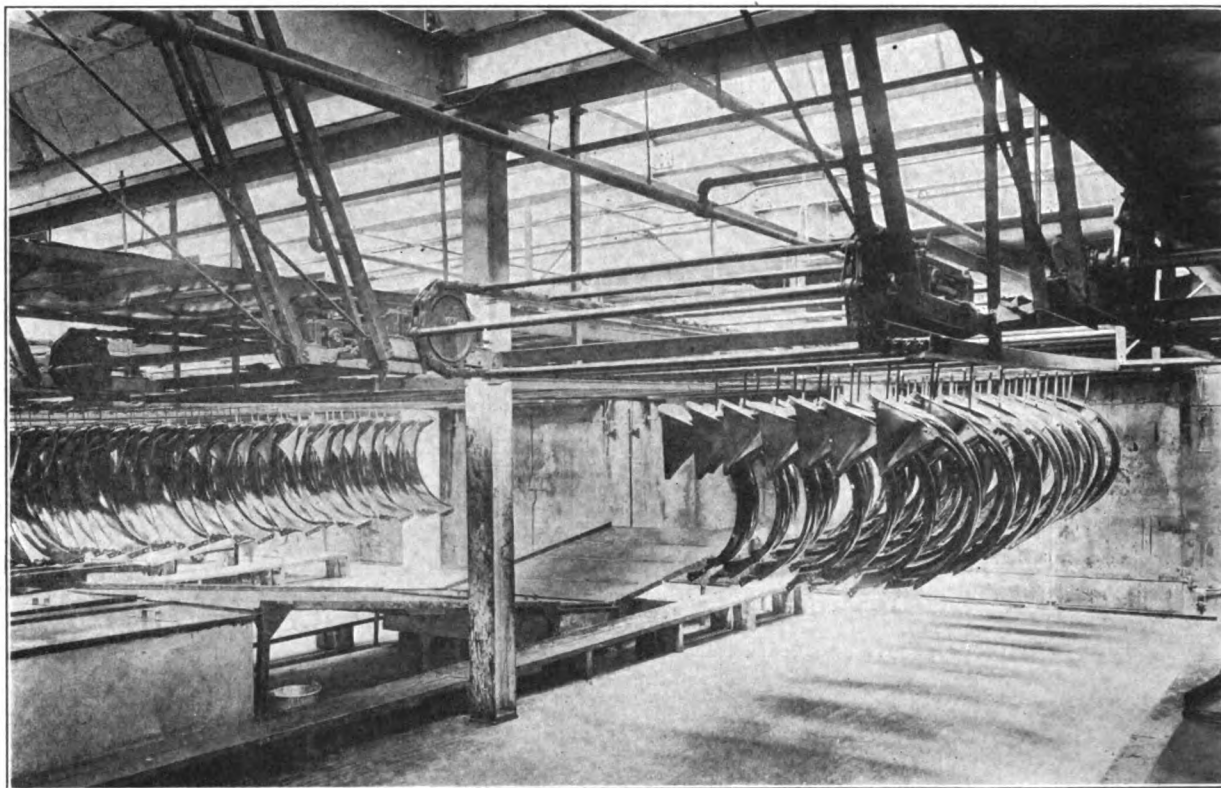

After the parts are dipped in the enamel they are hung on the cross bars of the conveyor, ready to be carried into the ovens, the fronts of which may be seen in the background of the picture

mechanical conveyors the parts are dipped in the first coat of enamel at the side of the conveyor and are then hung on the conveyor over drip pans in front of the oven doors. After the conveyor is loaded the oven doors are opened and the conveyor is set in operation and the load is carried into the oven. In this way the maximum capacity of the oven is carried into it at one time and it is necessary to

keep the oven doors open only a short time. While one conveyor load is being baked another load is being dipped and placed on a section of the conveyor outside of the oven.

When a load of freshly enameled parts goes into the oven the conveyor carries those parts just baked out the opposite side, and if they require a second coat of enamel

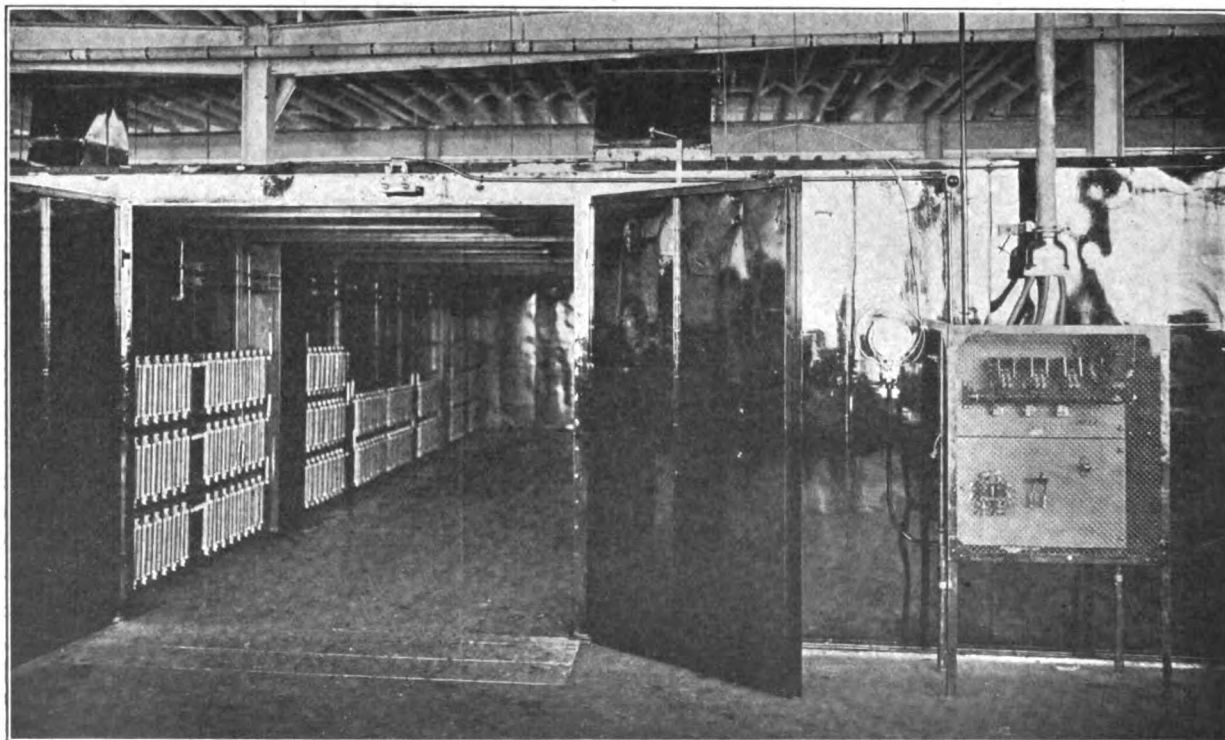

The electric heating units are distributed between the two compartments of the body baking ovens, for example, as here shown

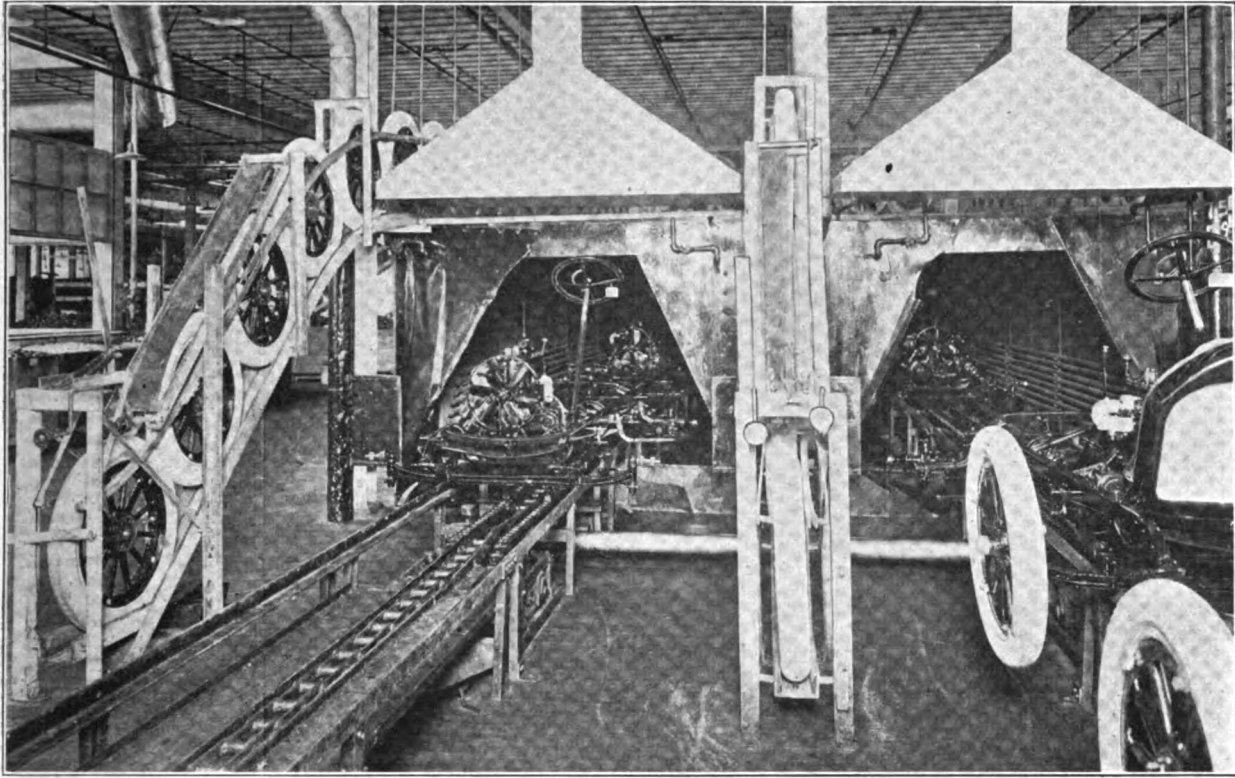

The chasses are shown coming from the steam heated ovens which are also used in the plant, ready for the application of the wheels

they are again dipped on that side and come back through the other half of the oven in the opposite direction. It will be seen from this that both the first and finishing coats are dried in the same oven, which, although a departure from the usual practice, is found to work out very satisfactorily.

The conveyor is of the chain type 8 ft. wide and 64 ft.

long, each end extending approximately 22 ft. outside the oven and providing outside loading space at each end. The conveyors are driven from one line shaft that extends in front of the ovens, each conveyor being operated independently by means of a clutch. It takes 2½ minutes for the conveyor to move approximately 21 ft. to carry a fresh load into the oven and to deliver the baked load,

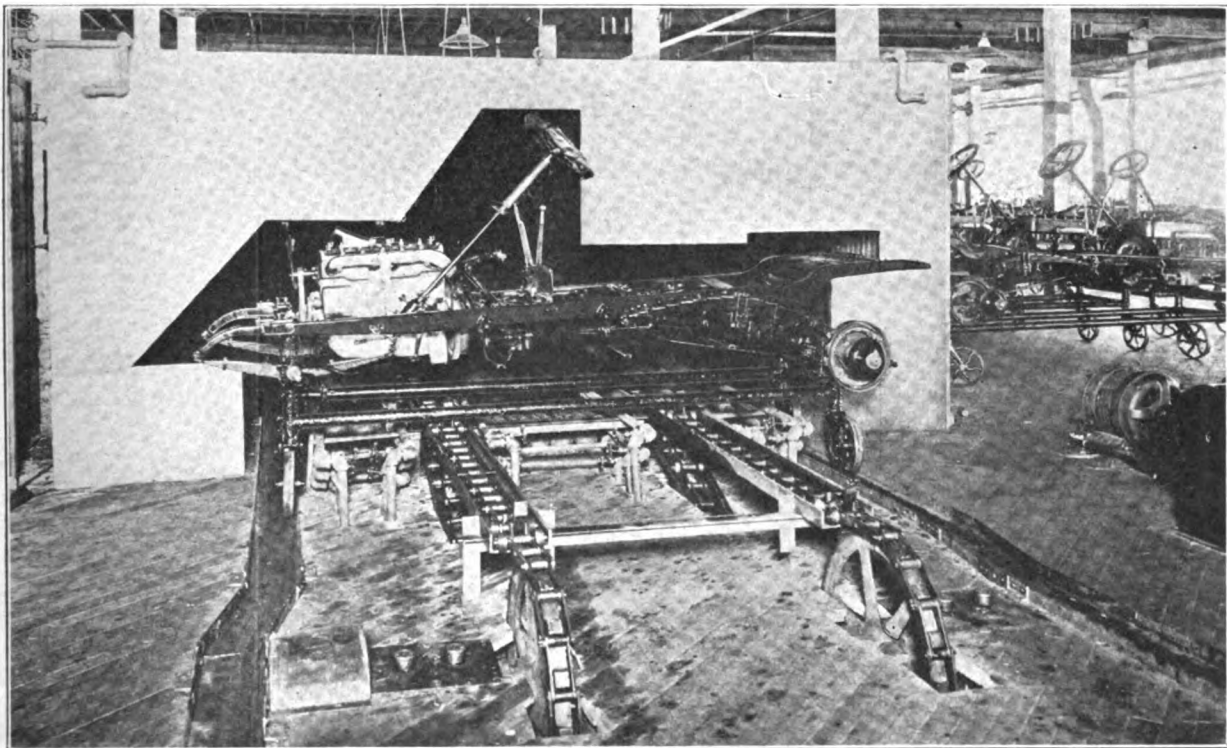

In this steam oven, the chasses are carried sideways on the conveyor

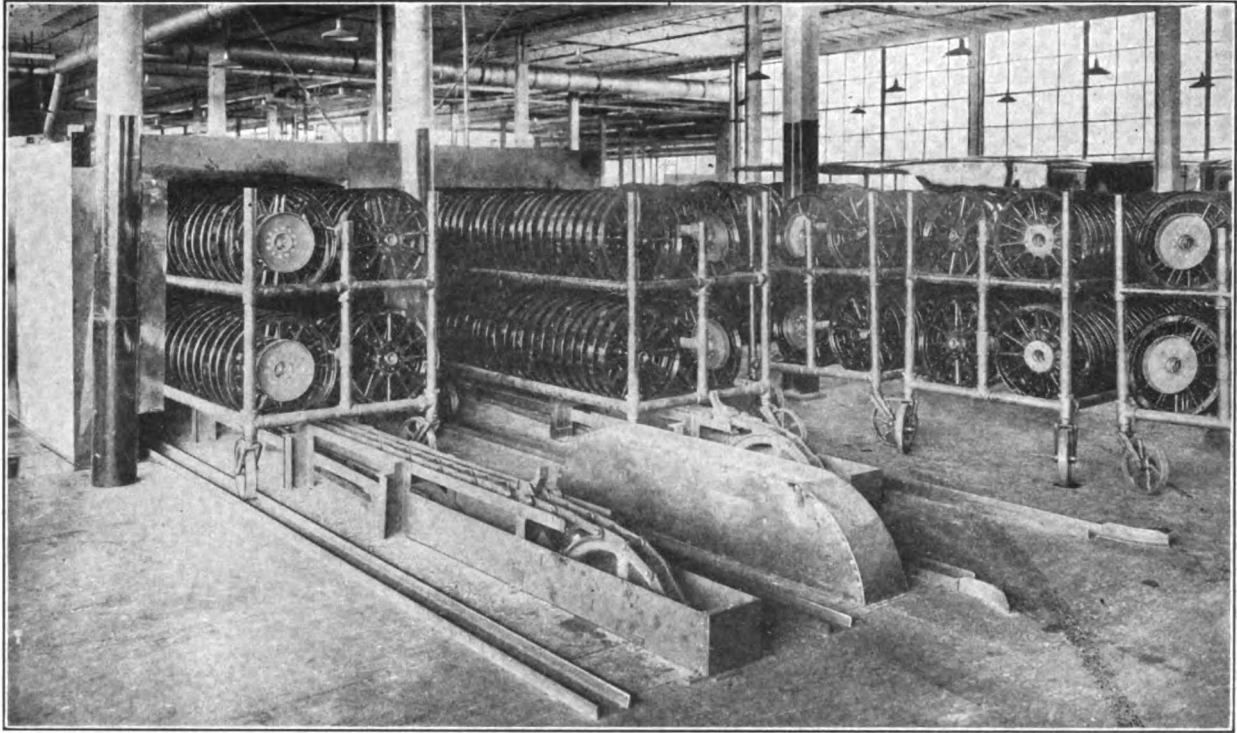

Special racks are used for carrying the wheels which are drawn through the oven by the chain conveyor

and during that time while the doors are open the oven temperature falls 85 to 100 deg. It requires only about five minutes to get the temperature back to the average temperature of 350 deg. required for baking. It is said that the ovens have a capacity of about three times that of the ordinary type of ovens without the conveyors.

For drying bodies there are two batteries of ten electric ovens each, one battery for drying the first coat of enamel and the second battery for the finishing coat. These ovens are 8 ft. high, 40 ft. deep and 21 ft. 6 in. wide, making the length of each battery 215 ft. For drying the fenders of one model of car, there is a battery of six electric ovens 20 ft. wide and 20 ft. deep. These ovens have a capacity for baking 500 sets of fenders with two coats of enamel in a day. There is another battery of ten electric ovens for fenders and four electric ovens for hoods. Two electric ovens are used for drying the running boards, shields, aprons, under panes, etc.

Two of the illustrations show a battery of chassis drying ovens. These are steam heated ovens about 150 ft. in length. The chasses, after being spray painted, are carried through the oven on a conveyor, taking about 50 minutes to pass through. The ovens are kept at a temperature of about 180 deg. The assembled wheels are carried by gravity to the discharge end of the oven to be assembled to the chassis, as shown in one illustration.

While the first cost of the electric ovens is much greater than gas-fired ovens and the cost of operation is higher, it is found at the Overland plant that this increased cost is fully offset by the increased efficiency, quicker handling of material, greater production for the same amount of oven space, improved work and lessening of the fire risk. It is stated that the required temperature is attained much quicker than in gas-fired ovens. With the regular electric ovens without conveyors, the first coat of enamel is baked in 1 hr. 10 min. and the finishing coat in 1 hr. 40 min., a

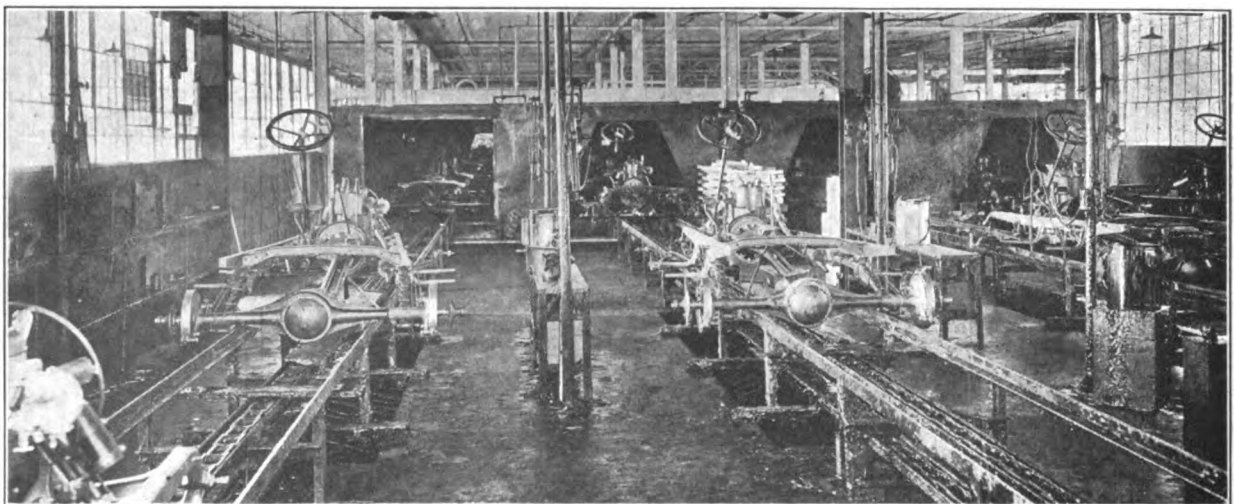

The conveyor for the chasses looking in the direction of travel or toward the ingoing end of the steam-heated oven

total of 2 hr. 50 min., as compared with 4 hr. 15 min. with gas-fired ovens, which require 1 hr. 45 min. for the first coat and 2 hr. 30 min. for the finishing coat.

In the case of the conveyor type of ovens there is a further saving of time. In these the first coat is baked in 45 min. and the second coat in 1 hr. There are no dust particles and oils in the process of combustion to come in contact with the work while it is being baked. No draft is required, a small flue sufficing to carry all the fumes from the enamel.

The heating units are 14 in. long and 14 in. high and 4 in. in thickness. Each unit is made of eight coils or sections of flat resistance ribbon wound on oblong spools. These units are mounted on iron racks and are placed at each side of the ovens. The wide two-compartment ovens have a row of heating units in the center between the compartments. Electricity for heating the ovens is furnished by the Toledo Railways & Light Co., being delivered to the plant in underground cables at 23 000 volts, and the current is three-phase of 25 cycles. For use in the ovens it is stepped down to 440 volts. The heating units are of 10 kw. capacity.

From 9 to 42 of the units are used to heat one oven, the energy required for each oven ranging from 90 to 420 kw. Each oven is provided with a Taylor Tycos electric contact control instrument by means of which an even temperature is kept within a range of 10 deg. Each oven is provided with a switchboard, this being located in front of the ovens except in the case of the conveyor type, which have switchboards at one end of the battery. A thermometer and time dial are located on the door of each oven. When the oven doors are open the electrical current is automatically cut off.

The ovens were built by the Young Brothers Co., Detroit, and the heating units were furnished by the General Electric Co. The conveyors in the electric and other types of conveyor ovens were designed and furnished by the Link-Belt Co.

Leather and Its Substitutes

The following was sent out by the manufacturer of a leather substitute and makes interesting reading:

What's going to take the place of leather? Every day we hear of the increasing cost of leather. The European demand is stronger than ever before. Domestic buyers are covering their immediate needs only. Europe is bidding 15 per cent above domestic prices, and yet the export business is not over 10 per cent, as the balance is being saved for the American manufacturer. It is, however, understood that should sales follow the bidding that Europe could easily use 90 per cent of the production. This wouldn't leave much for the U. S. use.

This "watchful waiting" policy is hitting the leather purchaser, for knowing of the foreign demand the factory owner or manufacturer is shoving up the prices. Just an instance. How about shoes? Prices are advancing steadily. Good shoes are half again as costly as they were two years ago. Note the following:

"UMPH! NOW IT'S SHOES THAT ARE GOING UP, UP.

"Some Even Advance 72 Cents a Pair in 72 Hours.

"Pittsburgh, Oct. 15—Wholesale prices on men's and women's footwear have been advanced 50 to 75 cents a pair within the last 72 hours and certain lines have been

withdrawn entirely from the market owing to a big shortage in leather, according to an announcement here today by officers of the Pennsylvania Shoe Travelers' Association.

"The organization, which is composed of salesmen from various parts of the United States assigned to this territory was formed at a meeting last night. Many letters were read from firms manufacturing shoes announcing an advance of 37 to 66 cents a pair on upper stock and 8 to 10 cents a pound on sole leather. Two lines of shoes were advanced 75 cents a pair in two days."

Of course, leather is used for many other purposes besides shoes. The upholstery field needs it or an equivalent. The furniture, automobile, as well as steam and railway car industries use it extensively.

The increasing prices and shortage of hides is making the leather user think. At the present price he can't afford to use all genuine leather, hence for some uses he is being supplied with what is known as split leather. Said split leather is merely a sectional sheet of a hide. Such splits will, of course, not equal non-split hide leather for shoe soles, harness or belting. In fact at the present time shoe manufacturers have not found a suitable substitute for shoe leather, sole or uppers. In some cases as many as four splits are made from one hide. The top layer is used for fine book binding. The second, a thicker layer, still bears the natural grain of the leather and is known as genuine leather No. 1. It is used for upholstering high class automobiles and furniture. The third layer is thicker than the second and is soft and spongy, besides it has no natural grain. This part of the hide is again split. What these latter splits lack in appearance is put on by coating them with a surfacing compound and then embossing that coating so as to imitate the grain desired. But the strength isn't there, and the splits don't last, which adds misery to the life of the local dealer who sells the upholstered article.

Many manufacturers have found a way to avoid the effect of this fast wearing material. Leather substitutes are taking its place for many uses and especially upholstery. They are stronger than split leather, because while the latter is merely a sectional sheet of a hide, a leather substitute has for its base a specially woven very strong cotton cloth.

That's how some people are taking care of a product shortage. The world is full of changes. Some day we are liable to have substitutes for eggs.

Electric Trucks in America

Owing to the great predominance of the gasoline vehicle, which is evident in every city, the average person does not realize the extent to which electric trucks are used by merchants and manufacturers. A recent survey showed that there were in the neighborhood of 10,000 electric vehicles being used for freightage purposes in the United States. These trucks and delivery wagons are used in 124 different lines of trade.

Page Buggy Co. Doubles Force

The Page Bros. Buggy Co., Marshall, Mich., manufacturers of automobile tops, has recently doubled the working force of the organization and is in search for more men. The company is supplying the Briscoe Motor Co. and others with automobile tops.

Weight Saving the Watchword

The Institution of Automobile Engineers of England recently elected L. A. Legros to his second term of office as president. On the occasion of his inauguration, Mr. Legros made an address of great importance because of the insight it gives into manufacturing conditions in England and also because of the valuable data relating to the development of automobile engines.

In his introduction the speaker stated that since the special function of the automobile engineer, as contrasted with that of other engineers, is weight-saving, the I. A. E. might well be said to represent the weight-saving engineers. Weight-saving was the watchword of the bicycle industry, to which the Institution owed its birth, yet it had been an important factor in all the great advances that had been made in traction, whether on land or on water.

One of the most important technical features of the paper is the study made of the automobile engine, which is taken to symbolize the work done and progress made by the membership of the Institution. Mr. Legros finds that the progress made in engine construction has taken different directions for different classes of work, but in nearly every case the range of speed and the maximum speed have been increased as well as the torque per pound of weight. Torque is a fundamental conception, according to Mr. Legros, and its study has contributed greatly to progress in automobile design. Most manufacturers plot the records of their torque curve and others plot curves of fuel consumption. The torque curve gives more information about the performance of the engine in a car than does the horsepower curve. Moreover, it gives the data in a form in which they are actually wanted for all traction problems.

A large part of the address is taken up by torque curves of various types of engines. Data regarding the number of cylinders, bore and stroke dimensions, weight of fly-wheel and of engine are given for 130 different engines. Nearly 100 of these engines are designed for such types of service as public vehicle, commercial vehicle, passenger car and racing car. The remainder are V type, vertical type, radial type and rotary type aero engines. The torque curve is given for each particular engine, torque per pound of weight being used as a basis of comparison. The data from which these curves are constructed were obtained from the engine and automobile manufacturers in England and allied countries and in America.

Mr. Legros then passes to the consideration of the automobile engineer. He holds that an appalling waste has resulted because of the time devoted to the classics by the English educational system. Consideration of the educational system is called forth by the fact that the Council of the Institution and its committees give great weight to this factor in passing on applicants for membership. A plea is made for a greater knowledge of science by the members of every profession. It is stated that the appealing ignorance of technical and scientific matters among those on whom the responsibilities for running the war have fallen has resulted in most costly losses in time, life and in substance.

The address then considers the question of employment of engineers. The Institution is exceedingly active in placing its members. In reviewing the qualifications for membership of some of the other English engineering societies Mr. Legros stated that the older institutions should not relapse into the condition of mere examining

bodies. Apart from finding the means to encourage research and standardization, that is the end that the Institution of Civil and the Institute of Electrical Engineers are rapidly approaching. Neither did he wish that they become mere labor bureaus, capable only of bringing employe and employer together. There should, however, in Mr. Legros' opinion, have been some properly constituted body to which the government could have applied for the brains and specialized ability in engineering, which, during the war, it has from time to time required for different departments. He suggested that the engineering institutions should start an agitation to secure recognition of the mechanical engineer as a unit in the various branches of the military service.

"I repeat," said Mr. Legros, "this is an engineers' war, but it is more particularly a mechanical and automobile engineers' war, for the civil, mining and electrical branches of engineering, while taking their great and due share of the work, have not been responsible for the creation of either ordnance or munitions or for military transport of a kind and on a scale never before contemplated. Yet the mechanical engineer is not a recognized factor in the army! There is no Chief Mechanical Engineer corresponding to the Engineer-in-Chief of the Fleet, and it has been necessary to create a Ministry of Munitions to deal with vital questions of production; the same applies right down the scale, with the result that men of high mechanical ability and qualifications are officered by men with only ordinary military knowledge or mere administrative capacity."

In considering what is being done to win the war the work of the engineer is mentioned and Mr. Legros has found that about 5,000 professional engineers (apparently this includes the members of the civil, mechanical, electrical and automobile bodies) have enlisted.

In closing Mr. Legros stated that what will be wanted in the quiet period following victory is the influence of statesmen who can differentiate acceleration from velocity and who are enterprising and farseeing enough to control and direct the spirit of the age.

Winter "Joy Riding" in Canada

In snow the modern automobile does not stand much of a show. As in summer travel, the automobile can scarcely hope to be popular with younger Canada. A young fellow cannot steer an automobile with safety through snow and at the same time keep his arm around the dainty waist of May or Sadie! The cutter is one of Dan Cupid's best assistants and every farmer's son is well aware of the fact. What girl will forget the feeling as she swept down the street in a nice new cutter, the nag being piloted by Jim, while on the sidewalk stood another young lady who had also matrimonial hankerings after the said Jim? Along with the buggy, the cutter will continue to be the best kind of vehicle ever developed to go courting. The zip and tingle of the frosty air, the jangle of the bells and the swift, easy motion along the road, what man-jack of us, although we now prefer the fireside and a book, can forget these joyous days of youth? Bald is the bean that does not smile reminiscently over the long ago nights and the sleigh rides!

Give the modern farmer's son a nice, attractive cutter and a good horse which has learned when to trot and when to loaf, and the way to the marriage license bureau is easy!

Advertising a Factory to the Employee

How Folders Are Used in Pay Envelopes of the Cleveland Hardware Company to Emphasize the Attractiveness of Working Conditions

By F. L. Prentiss

Believing that the press agent is fully as important for the manufacturing plant as for a place of amusement, a system of publicity, the function of which is not to advertise its products to the trade but to advertise the plant itself to its employes and prospective employes, was placed in operation a few months ago by the Cleveland Hardware Co. in connection with its welfare department. This publicity is obtained through the form of attractive illustrated pay-roll folders containing interesting information about various features of the plant. The folders are designed to improve the welfare and working conditions of the men, and contain health hints, safety advice, talks on the evil effects of liquor and other matters of interest to employes.

The theory back of the publicity scheme is briefly as follows: The company in the operation of its plant requires a certain number of workmen and has created a certain number of jobs. If it were operating a retail store it would advertise its wares and they would be purchased by people desiring them. Instead of advertising its goods

that they are earning so much a day at such a plant come to think that the plant is a very good one to work in and a better one than almost anywhere else because of working conditions and shop convenience, not only will they be more content and less likely to leave to work elsewhere, but they will advertise the fact among their outside acquaintances that the plant is a first class one. Many of the latter will seek employment in the plant where working conditions are good. An advantage of this form of shop publicity is apparent from the fact that conditions may be equally good in another shop that does not advertise itself to its men in this way, but the men in the other shop may not appreciate what is being done for them because it is not brought to their attention in printed form.

A pay-roll folder is placed in each of the pay envelopes every week. The folders are neatly printed on thick paper and on the cover page is a few words in large type indicating the contents. One inner page usually has an illustration of some part of the plant of special interest to the

When you take a job, you should consider the things offered which are something more than wages.

Among the many things this company has to offer is membership in the Employee's Benefit Association.

One of the best and safest insurance societies in the country.

Workers here get for 25 cents what would cost them one dollar from a regular insurance company.

Nearly Fifty Thousand Dollars paid to members in the last fifteen years.

A careful man will think twice before losing membership in this society.

Be careful what you drink during the hot weather.

While hot weather is uncomfortable, it is not unhealthy. This is proved by the fact that we practically never have cases of heat prostration, and in nine cases out of ten, when workers are affected it is on account of something wrong with the stomach.

A bottle of good milk is cheaper and much more healthful than a whole pall of beer.

Take good care of your body and it will take care of you.

THE INFORMATION THAT TWO DIFFERENT FOLDERS CONVEYED TO EMPLOYEES

That on the left advertises the company's mutual benefit insurance association

The one on the right was added to the announcement of the sale of 20,000 bottles of milk by the company's stores in one month

for sale at retail, as it would do were it a merchandising company. It has places to be filled, and it follows the publicity method to present its wares in their most attractive form to the workmen, the wares in this case being positions instead of merchandise. This form of publicity is of particular interest at the present time when the demand for labor exceeds the supply and good workmen are particularly scarce. Under these conditions the best managed plant cannot hope to keep all of its good men, but strives to reduce to as low a percentage as possible the number of efficient employes who quit because of offers of higher wages elsewhere or for other reasons, and to add to its ranks other good workmen.

While the pay-roll folders do not go directly to the men not in the company's employ, they are designed to bring before the employes things about the plant that the company thinks the men should know, so that the men will feel it is a good place to work in and they will be less inclined to leave. The company believes that if the men instead of going no deeper into the subject than to know

men, such as the hospital, roof garden or an illustration showing the right way to do something in order to avoid accidents. On the opposite page there is timely advice to workmen in simple language about the care of the body, the avoidance of accidents and on various other pertinent topics. On the back cover page is the following, printed in nine languages besides English:

"Take this home and have some one read it for you if you cannot read it yourself."

That the folders are taken home and read is indicated by the fact that very few of them are thrown away in the shop. While a good many employes have left its employ to take other jobs since the plan has been in operation, the company feels that results have so far been satisfactory, and especially in view of the fact that its force of employes has been increased from about 1,500 to 3,000 since the plan was inaugurated.

While the company's publicity through its folders is designed to raise the standard of its employes by securing and keeping the best quality of labor and teaching the men

right living so that their efficiency will not be impaired, it is not expected that this plan will directly speed up production by arousing the men to do their best. Most of the men are employed on piece work, and in the opinion of the company the increase in earnings offered as a re-

The workers of The Cleveland Hardware Company have the benefit of the eight-hour day. The question is—
Is it a benefit?
The ideal is, eight hours each of WORK, RECREATION and HEALTHFUL SLEEP.
Do your hours of recreation bring you money returns? Recreation may be a benefit or a detriment according to its application.
Some of our workers recreate by gardening, farming, keeping stores, and other things which bring in money.
What about you?

A folder entitled "An Eight-hour Day"

ward for increased output under the piece-work system is not sufficient an incentive to spur a man to his maximum efforts. Other means are resorted to to get this increased production. The one of these that is regarded as the most efficient is the one that appeals to the man's sporting in-

A good sweat does more to get the poison out of our systems than anything else. Lots of rich men pay a dollar and more to take a Turkish bath, and it is nothing more than taking a good sweat.
This is the most healthy time to work in the forge shop. It opens the pores, lets out the poisons, and there is no cold draft which brings bad results.
A good sweat, lots of exercise, then a bath and good rest, is the best medicine. When you take medicine, take it regularly.
Eight hours work at the C. H. Co. every day, then a good swim in Lake Erie and a few hours' rest in the parks. Spend some money for a tent to sleep out in your yard, and you will never need a doctor.

Another folder bearing the caption "It's Hot and We Have Hot Jobs" was got out in the hot summer months

stinct to excel his fellows. Putting this theory in practical operation, various units either small or large are often pitted against each other. It may be one machine against another machine, a night turn against a day turn, one department against another department, or the company's

The workman cannot earn good wages unless he has a strong, healthy body.
The workman cannot earn good wages unless his home conditions are good—unless his mind is at rest concerning those whom he loves.
The Cleveland Hardware Company wants its workmen to earn the highest wages possible. There is nothing gained by having workmen who cannot earn good money.
The Cleveland Hardware Company has employed a trained nurse, who will give advice and attention, not only to the employes, but to their families, if they will but let us know their need.
Consult the nurse, if only for the slightest ailment.

This folder relates to the nurse

No. 1 plant against its No. 2 plant. Again information may come in that a competitor turned out a certain amount of forgings in a stated period, and both plants of the company will join hands in an effort to make a larger production record than their competitor.—Iron Age.

Road Building Economics

When a competent engineer is engaged to look after road building and maintenance, one of the first economics he makes in many cases is the utilization of local materials previously neglected or undiscovered, says the American Highway Association.

Sometimes plans for road building are prepared without proper investigation of local materials supposed to be abundant, and after the work has commenced it is dis-

covered the plans must be changed because the quantity or quality of the materials was overestimated. Gravel and crushed stone are very heavy and their transportation is costly, and every endeavor should be made to ascertain whether suitable materials can be obtained locally before they are imported at heavy expense.

The surfacing of a road costs more than most people believe. In the case of 87 gravel roads the grading and drainage averaged 41 per cent and the surfacing 59 per cent of the total cost; in 104 waterbound macadam roads the grading and drainage cost 27 per cent and the surfacing 65 per cent. In 53 bituminous macadam roads, these proportions were 27 and 73 per cent.

These figures show that more than half the cost of a surfaced road is generally spent for the materials and labor employed in surfacing the graded and drained road-bed. The good judgment that comes to an intelligent highway engineer through experience will often show him that instead of using local materials exclusively, as originally proposed before he was employed, the annual cost of the road to the taxpayers will be reduced by bringing in some material by rail. What he can accomplish in this way will depend on the knowledge of local materials which he can acquire.

Usually he is too busy to do much searching himself, but he can obtain much assistance if the local authorities will make systematic endeavor to ascertain the location of all ledges, sandbanks and gravel beds in their neighborhood. These are public resources of real importance, and should be a matter of record. In some communities school children have been encouraged to search for them, and in many places local amateur geologists and mineralogists have done a public service while riding their hobbies. There can be no question that the lack of complete knowledge of this nature is needlessly increasing the cost of road construction and maintenance in many parts of the country.

Henry Ford to Build Two Blast Furnaces

The Ford Motor Co., Detroit, Mich., has placed a contract with the Riter-Conley Co., Pittsburgh, Pa., for two blast furnaces to be built in Springwell Township, southwest of Detroit. They will be about 90 x 25 ft., and the output will be used in large foundries the Ford Motor Co. also proposes to erect. Julian Kennedy, Bessemer Bldg., Pittsburgh, is consulting engineer.

The location selected for the new furnaces is on the River Rouge, which empties into the Detroit River at Delray, just south of Detroit. As announced some months ago, it is the plan of the Ford interests to use metal direct from a mixer in the making of castings, and it is stated that the company's metallurgists expect, as the result of the experiments of the past two years, to produce a casting in this way having unusual strength, though no publication has been made as yet of the method by which this will be made possible. The plans for the operations to be carried on at the River Rouge site, which is 18 miles from the present Ford works, include an extensive plant for the manufacture of tractors.

Buggy Company in Bankruptcy

The Geo. White Buggy Co., of Rock Island, Ill., has filed a voluntary petition in bankruptcy. The liabilities of the company are placed at \$17,251 and assets at \$8,120.

Machining a Ball and Socket Joint

By Chester S. Ricker

On Paige-Detroit motor cars there is a ball and socket joint which has to be machined very carefully, as it has heavy duty to perform. This joint is located at the forward end of the torque tube which is attached to the rear axle. It serves a double purpose, i. e., to transmit the driving action and to resist the torque or tendency of the rear axle to rotate about the axis of the wheels. At the same time, it must be free to move about its center as the rear axles rises and falls, due to spring action. Furthermore, the center of the ball and socket must be coincident with a universal joint which the ball encloses. The methods of making these two pieces on a Bullard vertical turret lathe, the product of the Bullard Machine Tool Co., Bridgeport, Conn., are shown in the accompanying illustrations. About 50 per hour is the rate of production on both pieces, although output on the socket usually runs slightly less because of the additional work required in facing off the flange in addition to machining the socket.

Both tools are designed on the same principle. Heavy cylindrical bars are mounted in the turret, the end of these bars being slotted to carry the tools. The tool for machining the socket, Fig. 2, is a circular disk of slightly smaller diameter than the socket and of suitable thickness

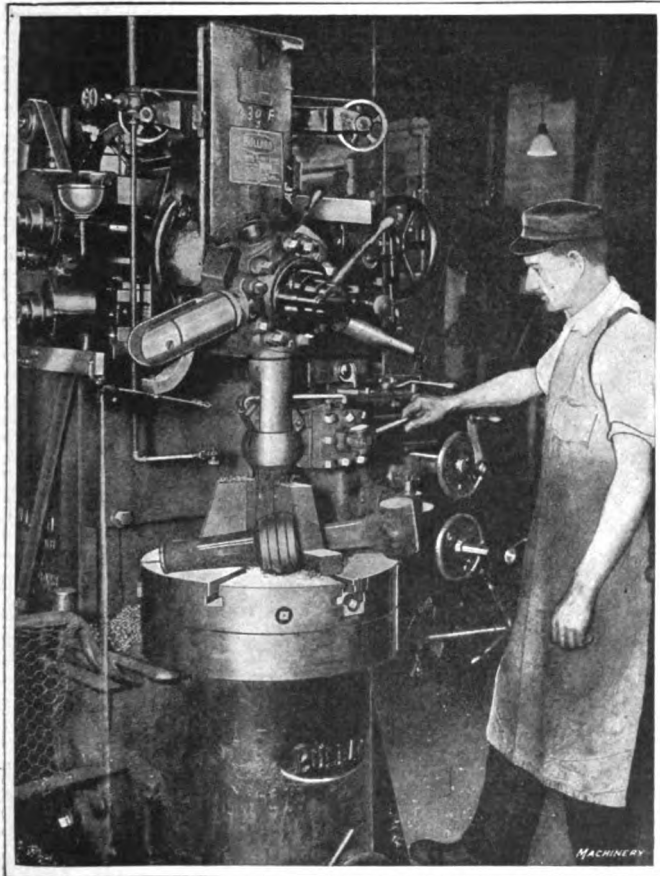

Fig. 1—Bullard vertical turret lathe tooled up for turning ball of a ball and socket joint

to just fit in the slot in the bar. A weight and cord are used to keep the tool out of engagement with the work. The cord is secured in place by a hook, so that it only requires a second to release it when the turret has to be rotated to the next position. The same is true of the feeding device which is hooked to the tool and to the

transverse tool holder. When the tool has been lowered into the work until the center is coincident with the center of the socket, the cross-feed is started, the work having already been started rotating.

The method of attaching the weight and the feed-bar is most clearly shown in the illustration of the ball. Fig. 1,

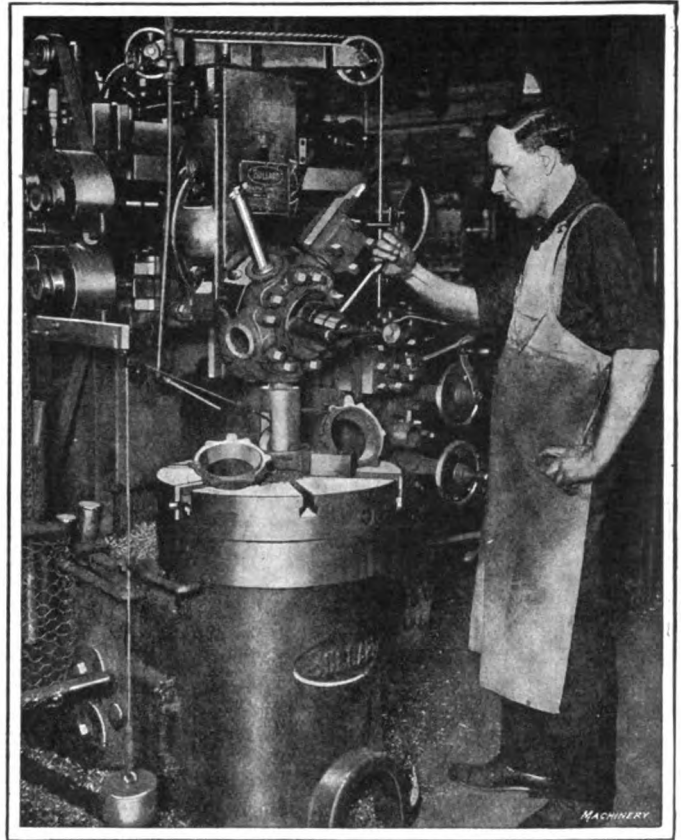

Fig. 2—Bullard vertical turret lathe tooled up for turning socket of a ball and socket joint

which also shows a piece of work unfinished, one that is semi-finished, and one in the chuck that is completely finished. The "semi-finishing" tool is shown at the left side of the turret in the first position above the tool which is at work. It shows very clearly the design of the tool holder and the rotary piece carrying the cutter. Both pieces are made from malleable iron.—Machinery.

Truthfull Advertising Vindicated

Meritas Leather Cloth Does Not Deceive According to the Federal Trade Commission

For some time past the patent and enamel leather interests, through their trade association, have been decrying the advance made in the variety of manufacture and use of artificial and imitation leather, or substitutes for leather, and have questioned the right of the artificial leather manufacturers to the use of the word "leather" in connection with their product.

Much agitation, including lengthy arguments in advertising form, has been brought about by the claims of each side—the artificial leather interests accusing the patent and enamel leather interests of deceiving the public by the production of split hides as against genuine grain leather, offering same as "leather" without specifying.

Finally, a complaint was made to the Federal Trade Commission under the "Unfair Competition" section of

the Clayton act. On February 18, 1916, the commission notified The Standard Oil Cloth Co. of New York, manufacturers of Meritas leather cloth, as follows:

"A complaint has been made to this commission that your company is engaged in producing, advertising and marketing, in interstate commerce, materials to imitate the finish and grain effects of genuine leather for upholstery use under what is alleged to be an erroneous, false, deceptive and misleading guise of 'leather,' designated under the brand or appellation of 'Meritas Leather Cloth,' and that the use of such brand or appellation on, and in reference to, said material, is an unfair method of competition in violation of Section 5 of the Federal Trade Commission Act."

The manufacturers of Meritas leather cloth denied the allegation and presented a concise statement of facts, together with samples of products, advertising literature, price lists, trade marks, etc., to show that there had been no violation of the law, and courted a thorough investigation.

It was a simple matter to point out that Meritas leather cloth is sold as "The Leading Leather Substitute," this line invariably appearing in each advertisement.

Further it has been stated that Meritas leather cloth is made on various qualities of cloth such as muslin, duck, drill, laminated cloth, etc. The goods are further offered 50 inches or wider in factory rolls of 12 yards. Nobody could imagine that they were buying real leather from real hides in such measurements even if the appearance of the goods did resemble real leather in finish and grain.

Not only has the price of genuine leather advanced greatly but almost all raw materials used in the manufacture of leather substitutes has increased likewise, so that the buyer must not only use his judgment but his eyes in seeing to it that he gets just what he asks for. The makers of Meritas leather cloth always stamp their trade mark on the back of the goods so buyers can identify the quality.

A lapse of practically six months occurred in which time the Federal Trade Commission investigated and considered the application of issuance of a complaint against the manufacturers of Meritas leather cloth. The commission then advised the manufacturers of Meritas leather cloth "that it would not be proper for it to forbid the use of the word 'leather' on such fabrics, provided the fact that they were not made of real hides of animals appears with reasonable clearness, by any appropriate form of expression."

Inasmuch as this company has always pursued the policy of making the above point plain by the use of the word cloth (leather cloth) it has, therefore, operated along the lines approved by the Federal Trade Commission.

G. M. PRENTISS.

Automobile Trade Good in Denmark

Denmark has never previously experienced such prosperity as during the last two years, and the increase in the number of automobiles registered shows that at present there is a good market there for motor cars of all descriptions. There were 5,718 automobiles registered in the kingdom on September 1, 1916, against 4,331 on September 1, 1915, and 3,430 on the corresponding date in 1914. The total indicated horsepower rose from 28,100 in 1914 to 35,200 in 1915 and 50,500 in 1916. Since the beginning of the war the increase has thus been 2,288 cars and 22,400 horsepower. The following table shows the number of motor cars registered in Copenhagen, the provincial cities,

and the rural districts on September 1 of the years named:

District.	1909	1912	1914	1915	1916
Copenhagen	417	824	1,454	1,675	2,128
Provincial cities ..	114	485	1,130	1,441	1,843
Rural districts....	151	278	846	1,215	1,747
Total	682	1,587	3,430	4,331	5,718

As will be seen from this table the increase in the number of registered automobiles from 1914 to 1916 is largest in the rural districts (901) and smallest in the capital (674) cars.

Of the 5,718 automobiles registered on September 1, 1916, by far the largest number, viz., 4,995, were for personal use. This number includes 1,461 which are used for cab or omnibus services, leaving 3,534 for private use. Auto trucks numbered 723. In 1914 there were 1,948 private automobiles and 351 auto trucks. The increase during the two years is thus 1,586 private automobiles and 372 auto trucks. The following table classifies these cars by indicated horsepower:

Horsepower	Cars for personal use		Autotrucks	
	1914	1916	1914	1916
Up to 6.....	1,105	1,725	109	192
6 to 12.....	1,676	2,485	165	344
Over 12.....	298	785	77	187
Total	3,079	4,995	351	723

Of the automobiles of more than five horsepower registered on January 1, 1916, 75 were of Danish make, 45 English, 588 American, 303 French, and 1,008 German. Some of these cars had motors rated above 40 horsepower.

N. I. V. A. Organizes Credit and Collections Department

A credit and collections department of the National Implement and Vehicle Association was organized November 21 at the association's headquarters. The following officers were elected: W. F. Arndt Emerson-Brantingham Implement Co., Rockford, Ill., president; H. A. Clement, Studebaker Corporation, South Bend, Ind., vice-president; M. E. Kolb, Champion Potato Machinery Co., Hammond, Ind., secretary-treasurer. The executive committee is as follows: R. O. Morgan, Oliver Chilled Plow Works, South Bend, Ind.; F. H. Farnsworth, Janesville Machine Co., Janesville, Wis.; W. M. Onion, John Deere Plow Co., Moline, Ill.; W. M. La Venture, J. I. Case Plow Works, Racine, Wis., with the above mentioned officers.

The principal subjects for discussion related to the uniform property statement and a simple set of business records for dealers.

Two Velie Companies Merged

The stockholders of the Velie Motor Vehicle Co. and the Velie Engineering Co., both of Moline, Ill., have given their consent to merging the two companies into one. The new company is to be known as the Velie Motors Corporation, and will be capitalized at \$2,000,000. No increase in stock is to be made and no new capital has been secured.

The Velie Carriage Co., which has been making horse-drawn vehicles for years, is unaffected by the merger, which includes solely the two motor companies. Matters of manufacturing and selling expediency were the cause for the consolidation it being realized that the one company would be able to command its market much more fully than either. The personnel of the directorate remains unchanged.

Paint Shop

Painting the Automobile Quickly and Cheaply

Get the car up on some strong wooden horses to let the wheels swing clear. If it can be put up high enough to allow one to work under it conveniently, so much the better. Remove the wheels and start to clean the chassis. First saturate the parts with a mixture of one part crude oil and two parts of turpentine. Let this soak in for a while, over night, if possible. Then with steel scrapers, putty knives, and scraping knives, proceed to work the grease and surface accumulations from the surface. The professional painter usually charges anywhere from \$5 to \$10 to clean the car ready for painting; perhaps you may be situated so that you can do it for \$2, or at most, \$3. It is a big job anyway, and if it is well done it will be worth all that "the traffic" will stand. A car, nicely and thoroughly cleaned is partly painted, is the way the painter puts it, as a rule. It will be a hard job to get all the traces of oil and grease, and probably renovator, off the car body. The best way is to rub the surface with water and pulverized pumice stone, and then wash clean with cold water. Next, look the job over and with a bit of oxide paint, applied with a small pencil brush, touch all places from which the paint has been knocked off, or all places, in fact, which show flaking or fracturing of the paint. The purpose of this is to get these spots coated with a paint carrying oil and pigment specially designed to stick fast to the metal or wood, as the case may be, and to hold up the color to come next. Some, if not all, of these spots will need puttying with a hard drying lead putty, in order to fetch the cavities up level with the surface, as a whole. This putty will dry over night. Then sandpaper it down to the level with the rest of the surface. Next touch the spots with the body color, and then a little later coat the body surface over entirely with color, japan ground, which in a short time will dry firm. Next flow on a coat of varnish color, and when this is dry, lay the gloss down by rubbing lightly with a soft wool sponge dipped first in water to moisten it, and then brushed across a bit of pumice stone flour. Clean up carefully; washing through a couple of water supplies, dust off well, and flow on a coat of durable car body finishing varnish.

The chassis or running parts, after cleaning had best be looked over, and wherever the paint is chipped or worn off, the places may be touched up with the same oxide paint used on the body. If necessary, putty these spots, sandpaper down in due time, touch with the color to be used, and then coat the parts in solid with the color selected. Choose a color in harmony with the color used upon the body; always a lighter color, for best results. Now apply a coat of varnish color, which can be made of four ounces of color and one pound of varnish, quick rubbing varnish being best adapted for the purpose. The following day apply a coat of hard, drying gear or chassis varnish, putting on all the surface will carry, as a means of bringing out the fullness of finish. The finish may be made in six days safely. It is a quick and good job, and if reliable paint and varnish is used, not necessarily the

finest and most elastic of varnishes, but a good, trustworthy article, the work will stand well and give good value for the investment. In the small town such a job should fetch, at least, for a four-passenger car, anywhere from \$35 to \$40, and for additional work proportionately higher figures. The putty mentioned above is mixed as follows: Dry white lead, two parts, by weight; best bolted whiting, one part, by weight. Liquids, equal parts of rubbing varnish and coach japan. Mix to a condition to handle freely without sticking to the hands.

If desired, the job can be cheapened to the extent of \$5, at least, by omitting the coat of color. Simply touch up the surface defects, as above noted, and then flow on a coat of varnish color. For the modest priced job this method has its advantages; it reduces the cost materially, and furnishes a durable piece of work.

Some car owners, says M. C. Hillick, in American Blacksmith, even suggest leaving off the finishing coat of varnish, letting the car go in what has been named "the house paint finish." For the minimum low price job, the work may be surfaced as already directed, touched with color, and next coated with one application of the varnish color, increasing the quantity of color, in proportion to the amount of varnish, to the extent of two ounces of color, making the proportions six ounces color and one pound of varnish. This will deaden the gloss, increase the covering properties, and bring the finish quite up to the house paint gloss. A four-passenger touring car can be turned out by this method for about \$20, at a fair profit, one job with another.

Practical Points for the Small Shop Painter

The small shop painter is almost certain to have considerable waste of material unless he exercises much care in the preparation and handling of the various paints, colors and varnishes. The opened container can never be closed to its original state, following the removal of some of the contents, and this permits a certain amount of evaporation to go on. It is advisable, therefore, to buy in the case of small, or comparatively small, daily requirements, with directions to have shipments made in quart, and even in pint, cans, in order to save the material from becoming thick or rancid before it may be used. This especially applies to all liquid and fluid supplies. In the matter of colors, it is also advisable to consider the extent of one's daily or weekly needs, when ordering, for here, too, there is chance for no small waste of materials which at this time run into money fast. In this buying, it is also well to get supplies direct, so far as possible, from the manufacturer. In this way a better quality of stock, as a rule, may be obtained, with the resultant advantage of saving the profits of the middlemen. The prevailing high cost of everything that goes into finished product makes it necessary to eliminate all extra expense.

Nevertheless, it is equally important to buy good stock; there is nothing that will hurt business more quickly, or

to a greater degree, than the use of an inferior brand of paint shop supplies.

It is always the best policy to buy for quality first; then get the best quotation possible consistent with the quality of the goods. This, in the end, is the true economy, and it applies quite as forcibly to the small business as to the large one. The big shop is only the outgrowth of the small one; a legitimate expansion based, primarily, upon the square deal. When a can of color is opened, and part of the contents removed, it is economy to pour a little turpentine over the surface of the pigment to keep it soft and workable; then, as a second precaution, replace the cover as tightly as possible. A good practice is this, and it works to advantage in the handling of all colors, and most of the coarser paints, even. It is cheaper, for the most part, to obtain colors japan ground, ready for simply thinning with turpentine, than to attempt to compound them from certain other pigments, however finely prepared such pigments may be.

It is, of course, necessary to often mix a color to match something which the vehicle owner may have in mind, or a sample of which he may be able to produce, but these cases are the exception, not the rule. In the case of a car or carriage coming to the shop in a badly scarred or faded condition, it hardly ever pays to try and touch up the marred or fractured spots, for it is next to the impossible to get a correct match, and when this is done, the job is never satisfactory, and serves as a black eye to the paint shop. The safest and most economical practice is to touch the spots with some color close to the old, faded and broken one, and then go over the entire surface with a fresh coat of the original color. This fetches the job out in a one shade color, and leaves no chance for grumbling. It is a quicker method and a more efficient one.

There is sure to be some left over colors which it is possible to utilize by mixing them together and thereby develop something original which, given a striking name, will catch the fancy and please the color sense of some car owner who is looking for something different than anything displayed by his neighbors. Some of the shades of green, or brown, or blue, or red, when mixed in right proportions, result in a smart color suitable for almost any vehicle of the average run. Anyway, there is always a call for something unique or different than the usual list of colors, and this gives the opportunity for working off the shelves the odds and ends which in time accumulate.

The left over bits of varnish, varnish color, etc., may also be put to good use in the preparation of coatings for some of the out of the way parts of the car or carriage, where a mixture of various ingredients will answer fully as well as a more costly material.

During the cold months it is a wise plan to keep the varnish supply stored in a warm place, where the heat is maintained at a uniform degree. The chilled varnish is dangerous to the painter's peace of mind; it likewise lessens his profits.

In the small shop, writes M. C. Hillick, in the *American Blacksmith*, it is quite a common practice to mix different makes of varnish, and different grades of the same varnish, as a means of getting something to meet the special or individual requirements of the business. This, as a rule, is a poor practice, and in the end is seldom satisfactory. The varnish maker is now able to furnish all grades and kinds of varnish, suited to every individual need, so that there is really no excuse for attempting to improve upon

his work by shaking two or more makes or grades of varnish together. There are laws of chemistry involved which make the practice extremely uncertain, if, indeed, not disastrous.

In handling a small business, it is not best to employ a wide range of the makes and colors of the more sensitive sort; usually these colors need special treatment which the small shop painter is not in a position to give. There are a great number of fine, solid covering colors, easy to prepare and apply, with which the workman not widely experienced will have no trouble in using; from them he can get good results, and there will be no grumbling from the vehicle owner. For example: black, blue (omitting the transparent ones), green, maroon, brown, and many of the reds, together with the yellows practically all of which are opaque. After putting on a coat of almost any one of these colors, some of the color may be taken and by adding a pint of rubbing varnish to three or four ounces of the color, after thinning it up somewhat with turpentine, a good varnish color may be made with which the surface can be brought up with a single coat, in the case of medium priced work, for the finishing varnish, thus making a quick and cheap finish. It is by taking advantage of these little things that the painter located in the small shop is able to make both ends meet and have something left over for the bank account Saturday night.

Another point for the small shopman to observe, is to have his work, when the paint and varnish are drying out, placed in a room uniformly and well heated, and for quick results the higher the temperature, consistent with safety, the sooner it is possible to move the jobs out of the way, and get others in. The quick handling of work is a big factor in increasing the productive capacity of the shop.

Prices of Paint Materials Very Strong

With a fairly active demand for paints and paint materials reported by numerous distributing centers, moderate available supplies and a restriction on prompt deliveries due to inadequate transportation facilities, prices are showing a strong upward tendency. The attention of the trade of late has been especially directed toward linseed oil, because of the sharp advance in that commodity. The rise in price was due to reports, since verified, of material deterioration to the Argentine crop of linseed and a moderate domestic yield, a combination which is causing predictions to be made of \$1 oil. The trend of china wood oil, soya bean and other oils used in the paint industry is also toward a higher level and this is causing some apprehension as to the effect on consumption. There is a fairly brisk demand for lead and zinc pigments and prices are very firm, owing to the strength of raw materials. Dry colors are being taken in small but numerous lots, buyers operating with conservatism, because the light available supplies of most articles are maintaining quotations at a very high point. Varnish gums are none too plentiful, and as demand is steady prices are firm. Consumptive demand for turpentine is not very active, but support given by large buyers in the south prevents any material decline in quotations. More interest has been shown in rosins of late, especially in the lower grades, and with reports of increased purchases for export the market has developed a substantial gain in strength.—Dun's Review.

The Moreland Motor Truck Co. will erect a factory at Los Angeles, Cal.

Meeting C. B. N. A. Executive Committee

The annual meeting of the executive committee of the Carriage Builders' National Association was held at the Hotel LaSalle in Chicago, November 16.

The meeting was called to order by President Luth, and P. E. Ebrenz was elected chairman of the executive committee. P. P. Hunter was made secretary pro tem in the absence of Secretary Henry C. McLear, who was unable to attend, the first meeting of the executive board he missed in 38 years. A letter was read from Secretary McLear showing that the dues for 1916 were equal to the previous year.

P. E. Ebrenz was appointed councilor of the C. B. N. A.

following which will be dancing, which seems to interest all the visitors deeply.

On Wednesday evening the association will give a smoker for the gentlemen, so there will be a general exchange of business conditions, pro and con, between the manufacturers and the accessory trades, and it has been thought that this will be a big feature this year.

A general reception will be held just in advance of the annual banquet Thursday evening, which in a measure takes the place of the reception usually held Tuesday evening.

It seems to be the idea of the manufacturers of vehicle parts that the carriage manufacturers are not giving

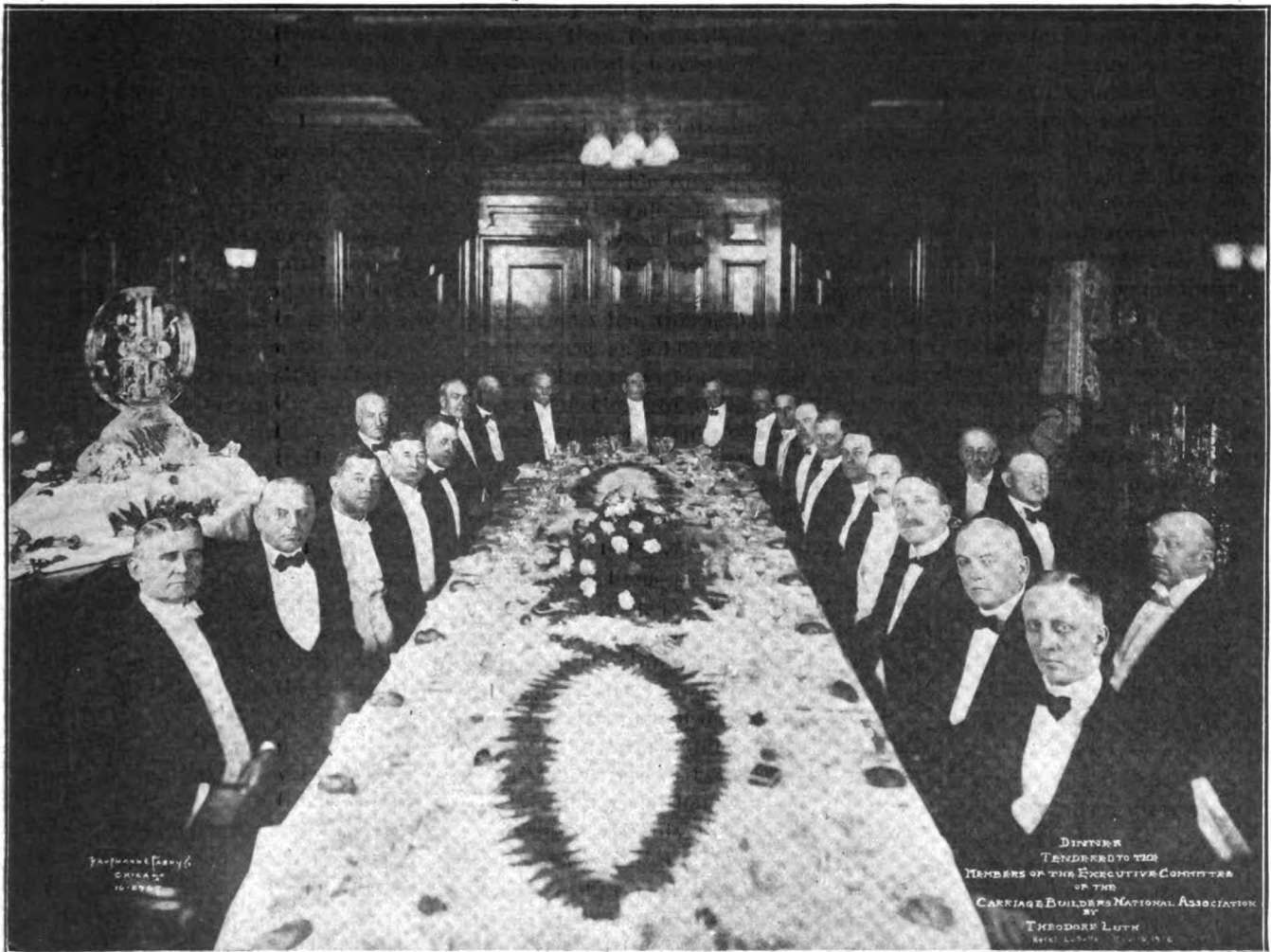

President Luth's Dinner to C. B. N. A. Executive Committee

to the National Chamber of Commerce, and also elected chairman of the executive committee.

The sum of \$500 was appropriated for continuing the important work of the freight and classification committee. The committee on statistics received \$100.

The week of September 24-29, 1917, was selected for the next annual convention, which is to be held in Chicago. The Hotel LaSalle will provide a large exhibit hall on the 17th floor, with two express elevators for special service.

It is the intention of the association to change the order of the entertainment to the extent that the association will do away with the formal reception usually held Tuesday evening—in lieu thereof the C. H. A. T. will hold a reception and dinner in which the ladies will be included,

enough attention to the changing conditions, that they are lax in the understanding of their cost and more lax in regard to terms.

The matter of standardization was considered in the executive meeting, it being the concensus of opinion that this matter would largely be up to the manufacturer of the accessories to bring about standardization in parts, as they are all interested in making a less variety and fewer sizes; and the standardization will apply to almost every part of a vehicle, especially wheels, axles, spring shifting rails, joints and more especially seats and bodies, which will govern the size of dashes, boots and carpet, and instead of a forging plant making 126 sizes in shifting rails, it can be brought down possibly to 10 sizes; hence the

wonderful desire on the part of all to have standardization.

A resolution was passed to have the following paragraph on the stationery of the C. B. N. A.: "Good roads, properly constructed for the safety and convenience of the horse-drawn vehicle and the automobile, lead to prosperity. Work for good roads of that kind."

Several impromptu talks were made, everybody being decidedly optimistic as to the present conditions in the horse-drawn vehicle industry.

The following were chosen to act as the entertainment committee for the 1917 convention: Geo. B. Ogan, chairman, L. C. Chase & Co., 326 W. Madison street, Chicago; W. C. Martin, Illinois Iron & Bolt Co., Carpentersville, Ill.; Chas. M. Bradley, Standard Varnish Works, Chicago; Harry B. Staver, Staver Automobile Co., Chicago; J. H. Rowen, Vehicle Department, Chicago; E. J. Baker, Farm Implement News, Chicago; Fred A. Hastings, Republic Rubber Co., Chicago.

At the same hotel on the evening of the 16th, Theodore Luth, president of the C. B. N. A., gave his annual dinner to the members of the executive committee and a few other guests. Following is a list of those who were present:

Messrs. P. E. Ebrenz, W. H. Röniger, W. A. Sayers, W. H. McCurdy, Thomas M. Sechler, Perrin P. Hunter, C. A. Lancaster, H. B. Staver, Geo. W. Huston, Geo. B. Ogan, Chas. E. Adams, E. J. Baker, W. C. Martin, E. J. Hess, Homer McDaniel, Earl M. Galbraith, O. B. Bannister, C. J. Rennekamp, Jos. A. Niehaus, John O. Flautt, A. M. Ware, Glen Perrine, W. P. Champney, C. R. Crawford.

After the dinner short addresses were made by Messrs. Adams, McCurdy, McDaniel, Ebrenz, Galbraith, Bannister, Hess, Sayers, Champney, Hunter, Flautt and Sechler.

A Dealer's Views on the Wagon Trade

"I never sell a wagon without instructing the buyer how to care for it," explained a successful dealer to a Farm Implement News representative. "There are many farmers who take good care of their binders, engines and other machines, but are woefully negligent in the care of their wagons. I believe the farm wagon is the victim of more abuse and neglect than any other part of the average farmer's equipment. It stands to reason that the best wagon manufactured cannot give long service if it is exposed to the deteriorating effects of weather extremes, and is used carelessly. I tell a customer that his new wagon is a first class piece of equipment, and that it should receive good care so it will last and give service for years. It is possible to cut the life of a wagon in half by using it carelessly, and on the other hand it is not difficult to prolong the life of a wagon indefinitely if proper care is given it.

"All wagons have a guaranteed carrying capacity of so many pounds; but in all cases the load should be governed by the condition of the roads. When the roads are level and free from ruts the wagon can be loaded to its full capacity; but where roads are rocky, filled with ruts and in bad shape generally it is idle to suppose as heavy a load can be hauled as in the former instance. The purchaser of a wagon may have radically different views regarding its proper use and care than the manufacturer; and I find it advisable to let him know just what the manufacturer's guarantee means. This policy prevents friction between customers and myself.

"When not in use, wagons should never be left out in the open. When exposed to the elements for any length of time the iron rusts and the wood parts decay. A few years of such treatment will send the best wagon manufactured to the junk pile. If a customer informs me that he has no implement shed and cannot afford to build one, I advise him to cover the wagon with a good tarred wagon sheet when it is not in use. The tarred sheet gives both the box and running gear a great deal of protection from the elements.

"A new wagon, in particular, should be kept well greased. In sandy regions sand may work in between axles and boxings; this sand must be removed or both axles and boxings will wear rapidly.

"I advise the purchase of broad tired wagons. For ordinary farm purposes I believe the broad tired wagon is preferable. The advantages of the wide wheels consist in their being drawn with much greater ease over soft ground, and they do less injury to alfalfa meadows, prairie meadows, etc., because they do not cut through and break the sod.

"Some of my farmer customers labor under the delusion that a farm truck is a farm wagon. This is a mistake. Wagons and trucks are two distinct articles, and are fitted for different kinds of work. I inform intending purchasers that they cannot expect a farm truck to do the work required of a wagon. The truck is adapted principally for use about the farm; there is a limit to its endurance and the limit may unexpectedly be reached if the owner uses it on the road for heavy hauling. I advise farmers to own at least one good wagon, and to also purchase a truck for auxiliary hauling. Trucks are especially adapted for use under hay racks. I never recommend a truck for heavy work on the road, for I know it will not give continued service under the strain of heavy traffic.

"When a farmer needs both a wagon and a truck, I sell him both articles; when he owns a good wagon but could use a truck to advantage for supplemental work, I sell him a truck. But it has been proven repeatedly that a truck should not be substituted for a wagon. The farm wagon has no substitute for its range of work.

"Some dealers have ceased specializing on the sale of wagons; they argue that they get better returns by concentrating their efforts on the sale of other articles. In the average instance I believe it is the dealer's own fault if he fails to make the sale of wagons a profitable issue. I handle quality wagons and am able to make a legitimate profit on their sale. There is no getting around the fact that quality wagons are the only ones worth handling, and there is no reason why the dealer shouldn't do a profitable business if he knows how to talk 'good' wagons.

"When passing judgment on a wagon the first consideration in the purchaser's mind is the quality of the wheels. The greatest strain comes on the wheels. Having examined the wheels and asked questions regarding them, the intending purchaser will inspect the skeins and axles; for the next greatest strain comes on these parts. I have information at my command concerning the construction of high grade wheels, skeins, axles, etc., and make a point of answering the intending purchaser's questions to the best of my ability. I inform prospective customers that a wagon cheap in price must of necessity be constructed of cheap materials; and that the high grade wagon will be the best investment in the long run."

New York a Field for Motor Trucks

Motor truck manufacturers can read the story of the picture printed on this page. It is a photograph of a daily scene on the east and west side waterfronts of New York City, and the predominance of horse-drawn vehicles, and the class of haulage they are handling, tells a story with a meaning of its own. The photograph was not taken especially for publication in this journal, but was purchased from a news agency which had photographed the scene on August 31 of this year. It is published here simply because we feel that it carries a message to the truck makers, of considerable importance. It shows that a field which offers large opportunity for motor truck service has not yet been developed to anywhere near its capacity. There is room for hundreds of motor trucks yet, and there is need of them, too. An intelligently con-

sidesthe adoption of modern ideas in buildings and mechanical equipment, strict safety-first rules and practices applying to every department. An expert devotes all his time to supervising the system. The plant has its central safety committee, a permanent safety committee composed of five foremen, and a department safety committee made up of all foremen and sub-foremen. Each committee holds conferences at regular intervals for the purpose of considering problems pertaining to the subject of safety in all its ramifications.

Inspections are made in every part of the works every day, and any condition which suggests the possibility of an accident or a fire, or which may endanger the health of an employe, is reported to the central safety committee and remedial action taken.

An assembly hall has been fitted up in one of the build-



SCENE ON WEST STREET, NEW YORK CITY

This photo was taken on August 31, 1916. There is not a motor truck in it

ducted, aggressive campaign, on the part of motor truck makers, should be productive of increased sales of nearly every type of truck. The horse is by no means supplanted, and the indications are that with the increased transportation demands, he will be supreme for a long time yet in New York City.

Franklin Factory Safety Methods

The H. H. Franklin Mfg., Co., Syracuse, N. Y., makers of Franklin automobiles, spend many thousands of dollars yearly at the company's plant in reducing fire hazards, safeguarding machinery, organizing accident-prevention work and in making the factory sanitary in every particular.

The elaborate and thorough system for the promotion of safety among the 2,300 or more employes involves, be-

ings and here weekly group meetings of employes are held and instructive talks given on safety first and first aid principles and practices.

Sanitation is a matter of paramount importance. Forces of men cleaners are engaged day and night in removing debris, scrubbing floors and stairways and in using disinfectants wherever required. No rubbish in which a fire might start is allowed to accumulate.

In addition to the usual fire protection facilities found in up-to-date factories, the company maintains a chemical engine, fire pumps and apparatus, and a well-drilled fire patrol, ready for police duty in case of emergency. Frequent fire drills make it possible for all the employes to vacate the plant in less than three minutes.

A hospital for treating first aid and even more serious cases is in charge of a company physician and surgeon

and assistants. Prompt reports on all mishaps is insisted upon by the company, for it is recognized that a trivial wound may eventually lead to a serious case of disability if not taken care of at once.

Important results have been obtained from this accident-prevention work. There has been a material decrease in the number of persons injured, in spite of the fact that occurrences of a class not previously recorded as accidents are now recognized as such.

Production Policy for Electric

The Anderson Electric Car Co., Detroit, has brought out an entirely new model, known as 68, which marks the introduction of a production policy for Detroit electric, and as a result this model will sell for \$500 less than its predecessor.

This cut from \$2,275 to \$1,775, in spite of greater increased cost of materials, represents the saving due to the installation of a large amount of labor-saving machinery and the adoption of a standardized chassis in which the number of options has been minimized so far as color and equipment is concerned. In upholstery there are three designs to choose from, while in painting there is one standard, whereas last year there was an unlimited field for either upholstery or painting. No sacrifice in material or workmanship has been made in any part.

The body is a brougham having a passenger capacity of four and is built on a chassis of 100 in. wheelbase with 56 in. tread. It has the standard Anderson motor with 42 cells, 13-plate battery, giving a speed of 6 to 25 m.p.h. and a mileage of 75 to 100 on a battery charge.

It is estimated at the present rate of increase the company's current year's business in electric passenger cars will exceed last year's by at least 100 per cent. The production of Detroit electric cars increased in 1916 over 1915 by 141 per cent, while the labor increase was not 100 per cent. This ratio is due to the introduction of a large amount of machinery.

The first four months of this fiscal year show an increase of 79 per cent over last year. A new four-story service building of brick has been erected which has a capacity of 400 cars, with repair and charging facilities and a large show and sales room.

U. S. Wheel Corp. Organized to Make Baker Pressed Steel Wheel

The U. S. Wheel Corporation has been formed in Chicago for the purpose of manufacturing the Baker pressed steel wheel for automobiles, motor trucks, tractors, etc. The new corporation, which has absorbed the Baker Wheel & Rim Co., will have a large capitalization. Factory location has not yet been decided upon. At the start production will be by having the most of the work done by pressed steel specialists. Production will be started soon after January 1.

The Baker pressed steel wheel is a flat-spoke type with spokes arranged bicycle-wheel fashion and held under tension. The wheel is stamped from an original circular piece of steel. It is first converted into a plate-shaped stamping resembling a large brake drum which would be the diameter of the wheel. By a further stamping process the spokes are formed. Alternate spokes attach to opposite ends of the hubs, giving two circles of spokes. The wheel is of approximately the same weight as an artillery wood

wheel for motor cars. At present two of the large automobile makers are testing the wheel, and others are arranging to test it.

Chas. G. Hawley, a Chicago man representing financial interests, will be president of the U. S. Wheel Corporation. Jos. A. Anglada, consulting engineer of New York City, will be vice-president. Erle K. Baker, inventor of the wheel, will be secretary.

Spring and Tubing Makers Consolidate

Plans for the consolidation of the Perfection Spring Co. and the Standard Welding Co., Cleveland, which have been under way for some time, have been completed. They will be merged under the name of the Standard Parts Co., which will have an authorized capital stock issue of \$35,000,000. This will include \$10,000,000 of 7 per cent cumulative preferred, only half of which will be issued at present, and \$25,000,000 common, of which \$8,000,000 will be issued. Of the preferred stock, \$1,000,000 will go to the shareholders of the Perfection Spring Co. and \$4,000,000 will be placed on the market. The common stock has been underwritten by a syndicate and will not be publicly offered.

It is stated that the new company will be the largest maker of automobile springs in the world and one of the world's largest producers of light gage steel tubing automobile rims, bands and bases for solid tires and bicycle and motorcycle parts. The manufacture of Perlman demountable rims will be continued under an agreement with the Perlman Rim Corporation.

It is expected that Christian Girl, president Perfection Spring Co., will be the active operating head of the new company. The directorate will include Christian Girl, F. F. Prentiss, H. P. McIntosh, Sr., H. P. McIntosh, Jr., T. E. Borton and Ernest W. Farr, of Cleveland, and Arnold H. Goss, of New York.

The net sales of the Perfection Spring Co. increased from \$907,384 for the year ended June 30, 1913, to \$3,142,587 for the year ended June 30, 1916. The net sales of the Standard Welding Co. increased in the same period from \$2,660,333 to \$5,123,722.

Nash Turns Out a Log-loading Truck

An unusual motor truck has just been designed and built by The Nash Motors Co., of Kenosha, Wis. It is a two-ton Jeffery Quad with a 142 in. wheel base, upon which is mounted a log-loading outfit. The truck was delivered to the Dayton "D" Handle Co., of Dayton, O.

Logs are rolled on to the flat body of the truck over a pair of skids by means of a device driven from the transmission. Two uprights with pulley arrangements are on one side of the vehicle's body. Wire cables are simply looped over the logs to be loaded, and when the motor is started they are pulled up over the skids.

The owners of this truck are using it to haul logs to the factory. Besides its self-loading feature, the truck is able to negotiate all kinds of rough going because of its power being distributed on all four wheels.

A Belt Dressing

About as good a belt dressing as can be had is made by melting beeswax in neat's foot oil in proportion of one-half pound of wax to one-half gallon of the oil. To secure a good mixture, melt the wax first, then add the oil slowly, stirring constantly to get it thoroughly compounded.

Truck-Forming Attachment for All Cars

The Smith Motor Truck Corporation, Chicago, has been organized to take over the Smith-Form-A-Truck Co. Additional capital has been provided to make it possible to include other cars than Fords in this truck-forming attachment.

Attachments are now being made for such cars as Dodge, Maxwell, Buick, Overland and Chevrolet. The new unit for application to other cars will be known as the Universal, although units under this name will not apply to all cars for some time.

Attachments for Maxwell and Chevrolet have a frame of 4 in. channel section, the same as the unit for Fords, and they sell at the same price as the Ford attachment or \$350. This unit will convert this car into a one-ton truck, but the larger size, the frame of which will be 5 in. channel section, will be designed for loads of 1,500 lbs.

Capacity for production of the attachment that has been made for Ford cars for the last two years is now 300 a day. Additions to the plant will be built which will practically double the floor space. The company expects to be able within three months to take care of any demand that may come for Fords or other cars.

The method of attachment for the newer units is the same as for the Ford; that is, the rear axle of the car is used as a jackshaft for chain drive.

Van Wagner Sells to Precision Die Casting Co., Inc.

The organization of the Precision Die Casting Co., Inc., of Syracuse, N. Y., at the head of which, as president, is Thomas G. Meachem, who is vice-president and general manager of the New Process Gear Corporation, in the same city, indicates the entrance of important new interests into the die casting field.

The new concern purchases and takes over the entire interests of Charles Van Wagner and merges the entire business of the Van Wagner Die Casting Corporation, which until a short time ago was the E. B. Van Wagner Mfg. Co., with that of the Precision Die Casting Co. Alterations and extensions that will make for improved quality and service in die castings have already been undertaken. The new company is capitalized at \$315,000.

In addition to the president the officers of the new company are J. W. Knapp, who was treasurer of the Van Wagner corporation, vice-president; H. S. Tenney, secretary of the Syracuse Trust Co., treasurer; E. J. Quintal, of Farrell, Sehl & Quintal, secretary. The directorate is composed of the officers and A. P. Bellinger, of the Solvay Process Co.; G. W. Bowen, of the G. W. Bowen Mfg. Co.; and W. A. Ball, of the Semet Solvay Co.

Electro-Pneumatic Gear Shift to Erect Plant

The Electro-Pneumatic Gearshift Corporation, Pittsburgh, will erect a plant for the manufacture of an electro-pneumatic gearshift. The actual power for shifting the gears is supplied by compressed air and contained in a reservoir and fed by a pump driven off the timing gears, there being an automatic valve for cutting in the pump when pressure falls below a predetermined amount. The air is also used for operating the clutch so that all the driver has to do is to move the switch lever mounted on the steering column.

It is stated that the magnetic operation of the valves

controlling the air is such that the gears and clutch can be operated at any speed desired. This should eliminate the shock which would be bound to occur if the clutch were engaged automatically always at the same speed. It allows for smooth starting and it also enables the driver to differentiate between a change up and a change down on the gears, operations which should not be performed with quite the same celerity. The inventor is John J. MacPherson. M. F. Metcalf is president of the company and Joseph C. Baird, secretary and treasurer.

Interesting Body Suit

The Fisher Body Corporation, Detroit, intends to take the most energetic steps possible to protect itself in the suit brought against it by the Springfield Body Corporation.

The suit promises to be one of the most important body cases of the year. The Springfield company bases suit on its two body design patents, No. 47,252, granted April 20, 1915, to Hinsdale Smith, and No. 47,630, granted July 20, 1915. One shows a car fitted with a top of the convertible type with the windows in place, and the other the same top without the windows.

The line of defense that probably will be adopted is clearly indicated by the statements of the Fisher company to be that of non-validity of the patent. It has stated that the prior history of the coach building art shows that "coaches equipped with removable or collapsible side window structures were in common use long before motor cars became general. Bodies of this type were mounted on European motor car chassis more than ten years ago."

General Motors Extensions

Detroit and three other Michigan cities, Pontiac, Flint and Saginaw, will receive the benefits of \$2,055,000 to be spent during 1917 by the General Motors Co. for new buildings. The new factory buildings for the Cadillac Motor Co. in Detroit will cost \$1,250,000. The addition to the Northway Motor Co., Detroit, will cost \$250,000. The Buick Motor Co., Flint, will get \$250,000 for a new administration building, and the Weston-Mott Wheel Co. plant will get \$125,000 for factory additions. The Oakland Motor Car Co., Pontiac, will be extended at a cost of \$100,000, and the Jackson-Church-Wilcox Co., steering gear manufacturer, Saginaw, will receive \$80,000 for an addition.

The General Motors Co. has also begun the construction of a building on Holbrook avenue and the Grand Trunk Railroad, to be used for the manufacture of motors for its allied companies. The building will be 200 x 734 ft., one story. The contract has been let and is to be finished in 60 days.

\$412,812 Verdict for Chapman

Henry S. Chapman, who sued the Peerless Motor Car Co., Cleveland, O., for \$800,000, which he claimed due him in commissions on sales of automobiles to England, was given a verdict for \$375,000 and interest by a jury in a Cleveland court. The total amount of the award is \$412,812. Chapman claimed that he secured the export representation of the Peerless company, but that when he was negotiating for a big order with the British War Department an agent of the company stepped in and took it away.

Large Railroad Equipment Orders

Orders for cars and locomotives in the first three weeks of November have been larger than for any similar period and exceed those for any month in the last three years. The Railway Age Gazette says that the railroad equipment manufacturers have booked 34,908 freight cars, conservatively put at \$1,500 each, or \$52,362,000; 256 domestic locomotives averaging about \$30,000 each, or \$7,680,000; 633 foreign locomotives worth conservatively \$8,640,000, and 416 passenger cars at \$17,000 each, or \$7,027,000—a total of \$75,754,000.

The second best month in three years was October, 1915, when orders were placed for 28,449 cars, of which 8,500 were for export. The best previous month in 1916 was October, when domestic orders were 21,034, or more than those for October, 1915. Domestic orders this year now (November 25) total 123,386 cars, compared with 84,298 up to the same time last year.

Domestic orders for locomotives in three weeks of November were 256, with foreign orders for no less than 633—a total of 889. For the year thus far domestic orders have been 2,386, as compared with 1,023 at the same time last year, or with a total of 1,612 ordered in all of 1915. Foreign locomotives ordered thus far in 1916 are 1,838. The locomotive builders and railroad shops of this country and Canada have ordered 4,224 locomotives this year. In the first three weeks in November 416 passenger cars were ordered.

Cleveland Plans Restriction of Trailer Use

The use of more than two trailers per motor truck will be prohibited in Cleveland, if a proposed traffic law as discussed in the common council on October 9, is enacted into law. In addition, the use of one or two trailers in connection with a motor truck will require that an extra man accompany the driver when such trailers are being used, provided the trailers are loaded with more than 500 pounds.

The proposed measure further provides that when a hill of more than 5 per cent is being ascended, the extra man must be on the rear trailer. The latter must also be equipped with suitable brakes or safety chains. The most objectionable feature of the proposed ordinance is perhaps that which would seek to forbid the use of the streets to any trailer with steel tires whose total weight, including its load, is in excess of 750 pounds. If this recommendation is made into law it will cause practically every semi-trailer in the city to be laid up.

Swift An Overland Director

Edward S. Swift, vice-president of Swift & Co., the well known Chicago packing house, has been elected a director of the Willys-Overland Co., Toledo, O. Swift is a warm friend and admirer of John N. Willys, president of the company, and a large holder of Willys-Overland stock.

Mr. Swift, as one of the heads of a great institution doing a business of over \$600,000,000 per year, is possessed of business and financial knowledge and facilities that will be most valuable to the Willys-Overland Co.

New Name Chosen

The Rex Buggy Co., Connersville, Ind., has filed articles showing that the name of the company has been changed to the Rex Manufacturing Co.

Win Material Freight Rate Reduction

Lindsay Bros., Milwaukee, have won an important victory in litigation to compel the railroads to reduce intrastate distance rates on agricultural implements, vehicles, and similar commodities in carloads. The Wisconsin railroad commission has ordered a material reduction to be placed in effect on January 1 by the North-Western, "Soo" and Milwaukee roads. Levying and collecting of group rates is ordered discontinued, and a distance rate schedule from 5 to 200 miles ordered substituted. The average reduction is 10 to 12 per cent from the rates now in effect.

Duryea to Build \$250 Car

The Duryea Motor, Inc., Charles E. Duryea, president, has been formed at Wilkes-Barre, Pa., with a capital of \$4,000,000 to build the Duryea Gem at \$250. This car will seat three persons. Other features include the Duryea patented roller drive.

Negotiations have been closed for a factory site and the Cutlery Works plant in the southern part of the city has been leased to start manufacturing.

It is planned to open the factory just as soon as 20,000 shares of the stock, par value \$5, are sold locally.

Kelly-Springfield Enlarges Plant

The Kelly-Springfield Tire Co. has found it necessary to enlarge its plant at Akron, O., immediately, in spite of the fact that the company is preparing to move to Cumberland, Md. Two frame buildings are to be erected at once. One will house the restaurant now on the top floor of the main building, and the other the experimental department, thus setting free space in the main building needed for other purposes.

Fire Damages Briscoe Mfg. Plant

The plant of the Briscoe Mfg. Co., Detroit, which makes fenders, hoods, tanks, radiators and similar metal parts for its parent organization, the Maxwell Motor Co., was damaged by fire on November 21. The blaze started in some enameling ovens, and did damage estimated at \$50,000 before it was extinguished. The plant was just about to close for inventory, and little interruption resulted to production.

A New Du Pont Product

The Du Pont Co., of Wilmington, Del., has just put a new product on the market. It is known as Pontoklene and is an automobile polisher and grease and tar remover. Automobile men are finding it a cleanser that removes tar, grease and dirt with ease and polishes with practically no rubbing. It does the work quicker and better than anything thus tried. Furniture can also be cleaned and polished with Pontoklene.

C. H. A. T. Entertainment Committee

The entertainment committee of the Carriage, Harness and Accessory Traveling Men's Association, who will look after that feature of the next annual convention, is composed of the following: W. C. Martin, chairman; George G. Ogan, W. R. Scott, G. W. Huston, Grant Wright and C. J. Rennekamp.

lton, Sibley & Co.'s New Building

Sibley & Co., Inc., Philadelphia, recently completed their new building on their own site where the firm was established 53 years ago, at 130-140 North Street, corner of Cherry, and invited the trade to visit on December 13. Guides conducted the guests through the plant, and at the informal luncheon which



congratulatory speeches were made by Messrs. Waterall, Edwin F. Beale and Stanley French. The building is a colonial fire-proof, six-story structure equipped with every up-to-the-minute device for the manufacture and shipping.

The first floor is devoted to the packing and shipping. The general offices and private offices are on the second floor. The grinding mills are also on this floor. An electric power plant supplies current for the engine, and all machines are driven by individual

motors. Particular attention has been given to the latest devices for the rapid and economical handling of shipments. The new building will give this old and well known firm increased facilities and enable them to take care of their constantly increasing business.

Following local paint people were present at the opening: Wm. Waterall and Edw. F. Beale, president and vice president, respectively, of the Paint Manufacturers Association of Philadelphia; Jos. W. Lucas, Alex. Lawrence, Geo. E. Nice, Benj. H. Shoemaker, H. E. Yarnall, Stanley French, Edw. H. Stulb, H. C. Stewart, W. H. Stewart, and A. M. Parks.

Taylor Recovers from Appendicitis

Taylor, general manager of the automobile axle department of the Hess Spring & Axle Co., Cincinnati, is recovering from a satisfactory recovery from an operation for appendicitis, on November 11.

Dort a New York Bank Director

Dort, president of the Dort Motor Car Co., has been elected a director of the Guaranty Securities Corporation, New York.

Trade News From Near and Far

General News of the Vehicle Trade

The Elkhart Carriage & Motor Car Co., Elkhart, Ind., has increased its capital stock from \$100,000 to \$300,000.

The McLaughlin Motor Car Co., London, Ont., will erect an addition to its plant on Richmond street, to cost \$6,500.

The factory of the L. F. Moore Carriage Co., Knoxville, Tenn., was destroyed by fire with a loss estimated at \$11,000.

H. M. Ashby, general manager Sherwin-Williams Co. of Canada, announces that his company will build a large dye plant at Montreal.

Plans for the new factory of the Harrison Mfg. Co., Lockport, N. Y., manufacturer of auto radiators, will be 163 x 396 ft., two stories, estimated to cost \$250,000.

The Trudeau Carriage, Ltd., Montreal, has been incorporated with a capital stock of \$49,000, by Theophile Trudeau, Maximilien Renaud, Jean L. Poirier, and others.

The American Auto Trimming Co., Cleveland, has leased quarters in a factory building of the Properties Co. on East 72d street, Cleveland, in which it will establish a plant.

The Velie Motor Vehicle Co. and the Velie Engineering Co., of Moline, Ill., have been consolidated under the name of the former. The capital stock of the company is now \$2,000,000.

The Chevrolet Motor Co., Detroit, plans the construction of an assembling plant in Portland, Ore. The site is already selected. The structure will be 100 x 200 ft. and will cost \$100,000.

The Eastern Motors, Inc., which was incorporated recently, has taken a lease of the former state trade school building owned by the American Hardware Corporation, of New Britain, Conn.

The Paige-Detroit Motor Car Co. has voted to increase its capital stock from \$2,000,000 to \$3,500,000 to provide larger working capital and to enable the company to carry larger stocks of material.

The Mayo-Skinner Mfg. Co., 54 East 18th street, Chicago, manufacturer of automobile accessories, has purchased factory property on Elston avenue, upon which a manufacturing structure will be erected.

The Monitor Motor Car Co., Columbus, O., has been incorporated with \$1,000,000 capital stock and will increase its automobile manufacturing plant heretofore operated under the name of the Cummins Monitor Co.

The Pierce-Arrow Motor Co., Elmwood avenue and New York Central Railroad Belt Line, Buffalo, has let contract for erection of a sand blast and pickling building of steel construction, to be erected at its plant.

The Pekin Wagon Co., Peoria, Ill., is running full capacity, but owing to a scarcity of materials the company will not accept any orders at present prices for delivery after April 1, and these orders must be on file by January 1.

The Frankfort Motor Car Co., Frankfort, Ind., has been incorporated with \$250,000 capital stock to manufacture automobiles and accessories. The directors are George L. Thompson, Frank E. Coulter and Robert E. Stevenson.

The House Wire Wheel Co., S. D. Morgan Building, Buffalo, N. Y., recently incorporated, is making arrangements for the erection of a plant for the manufacture of wire wheels for automobiles, on a site recently acquired.

The Martin Carriage Works, York, Pa., manufacturer of buggies and motor-driven fire-fighting apparatus, has been purchased by Fred M. Small, of York, and John J. Watson, of New York City. It is their intention to enlarge the plant.

The Brunswick Motor Car Co., Newark, N. J., has acquired property at Avenue B and Miller street, and will establish a plant for the manufacture of automobiles. Russel Smith is president and Alden V. Meeks, New York City, is treasurer.

The output of the Pontiac Chassis Co., Pontiac, Mich., which has been taken over by the new Olympian Motors Co., will double and then triple its output within a short time. R. A. Palmer is president and general manager of the Olympian Motors Co.

The Atlas Bolt & Screw Co., Cleveland, has disposed of its plant on Marquette avenue, and will erect a new plant on Ivanhoe road, adjoining that of the Atlas Car & Mfg. Co. A factory, 160 x 600 ft., and an office building will be erected. New equipment will be required.

The Shelter Wood Rim Mfg. Co., Portland, Ind., has been incorporated with \$35,000 capital stock to manufacture steering wheel rims for automobiles. The directors are Alonzo F. Bowers, Carl M. Bimel and Edward M. Haynes. Plans for a plant are under way.

The Auto Specialties Mfg. Co., with a plant at St. Joseph, Mich., has closed a contract with the Overland Automobile Co., to equip all its machines with the Bair auto top holder, the chief product of the company. The order involves the manufacture of 300,000 sets each year. A total of 3,000,000 holders will probably be manufactured at the new St. Joseph plant in 1917.

The Victor Motors Co., Philadelphia, recently incorporated with a capital of \$2,000,000, has acquired the former plant of the Wharton Switch Works, Jenkintown, Pa., comprising eight buildings and about 25 acres of land, for its initial automobile manufacturing plant. The former plans of the company to build a plant at Grubbs Landing, near Claymont, Del., it is stated, have been abandoned.

The Kent Motors Corporation, 1790 Broadway, New York, has approved plans for its new plant to be erected on Washington avenue, Belleville, N. J. The plant will specialize in the manufacture of bodies and radiators for touring cars and roadsters, and will have a capacity of about 10,000 cars a year. Employment will be given to about 2,000 men. Additional property has been secured for future expansion.

Doings of the Motor Truck Builders

The Buick Motor Co., of Flint, Mich., has ceased production of 1,500-lb. trucks.

The Dorris Motor Car Co., St. Louis, Mo., has discontinued the manufacture of its 1,500-lb. delivery wagon.

The Bestever Truck Co., Chicago, has been incorporated with a capital of \$100,000, by H. H. Ready, L. C. Coyner, 139 North Clark street, and Mrs. Nina Ready.

The Cadillac (Mich.) Auto Truck Co., maker of the Acme 1 and 2-ton trucks, will soon add to its factory a new concrete, steel and brick building, 96 x 176 ft. The new 3½-ton model is well under way.

G. E. Smith has become sales manager of the Blair Motor Truck Co., Newark, O. F. L. Swanberg has resigned as manager. The management of the factory will be in charge of J. P. McCune and F. O. Spaulding.

The Federal Motor Truck Co., Detroit, is erecting an addition to its factory and installing additional machinery. Another machinery building and assembling plant will be constructed immediately. M. L. Pulcher is general manager.

The Stegeman Motor Car Co., Milwaukee, manufacturer of motor trucks, broke ground December 1 for a one-story factory addition, 139 x 190 ft., at Woodworth and Linus streets, to relieve the pressure of its machine shop and assembly room.

The Lunn Motor Truck Co. is a new corporation for the building of automobile trucks at Aurora, Ill. Temporary factory quarters have been secured in the Downer Garage Building, where the concern will operate until a permanent building has been secured. The company will employ 25 machinists at the start.

Manufacture of motor trucks is to be undertaken in Waukegan, Ill., by the Manly Motor Co. Space has been leased in the Manufacturers' Terminal, and 75 men are to be employed at the start, turning out 2½ and 4-ton trucks. The company is incorporated for \$500,000. Its first year's output is already contracted for.

D. George Dery, reputed to be the largest silk manufacturer in the world, and Martin E. Kern, vice-president of the Penn Counties Trust Co., of Allentown, Pa., are interested in a new truck enterprise which is to be established in that city. A tract of land fronting 1,500 feet along the tracks of the Central Railroad of New Jersey, has been acquired as a site for the new plant.

Prices on two models were increased December 1 by the Chase Motor Truck Co., Syracuse, N. Y. The model "A," 1-ton goes from \$1,650 to \$1,725 and the model "C," 1½-ton goes from \$1,950 to \$2,025, an increase of \$75 in each case. Other models remain at present prices; model "T," 1,500 pounds, \$1,500; model "B," 2½ ton, \$2,475; model "X," 3-ton, \$2,800; and model "O," 3½-ton, \$3,300.

Mayor Hagarty, of Hartford, Conn., has received a letter from C. K. Thomas, of 639 West 51st street, New York City, president of the Thomas Motor Truck Co., in which the latter states that his company is seeking a site for a new motor truck plant. The letter also stated that a merger of three or four motor truck companies is being contemplated, which would produce 1,200 trucks the first year and would employ between 500 and 600 hands.

The directors of the Ypsilanti (Mich.) Motor Truck Co., recently organized by the stockholders of the Globe Motor Truck and Body Co., are H. R. Scovil, Charles N. Havi-

land, D. L. Davis, F. W. Paton, Frank R. Welsh, H. F. Schaefer and Gilbert E. Porter, all of Ypsilanti. A new factory will be constructed at Ypsilanti for the production of Globe trucks and bodies. G. E. Porter will have charge of the manufacturing and F. M. Woodward, of Grand Haven, Mich., will be in charge of the sales department.

A ¾-ton delivery car has been brought out by the Hoover Wagon Co., York, Pa. The engine is 3¼ x 4½ block cast design, cooled by thermo-syphon circulator through a cellular radiator. Ignition is supplied by a high-tension magneto with hand adjustable spark advance. The clutch is a three-plate design and the gearset has three speeds. Final drive is by shaft and two universals to a worm-driven semi-floating axle, torque and propulsion being taken by the spring. Both springs are located on the rear wheel drum.

The Duplex Truck Co. has been organized at Lansing, Mich., with a capital stock of \$1,000,000, to take over the business of the Duplex Power Car Co., of Charlotte, Mich. The plant of the old company will be moved from Charlotte to Lansing, where a factory large enough to greatly increase the output will be built. H. M. Lee, now assistant sales manager of the Reo Motor Car Co., Lansing, has been elected president and general manager of the new company, H. E. Bradner, vice-president, and Geo. W. Hewitt, now credit manager of the Reo Company, secretary and treasurer.

The Knickerbocker Motors, Inc., has been incorporated to take over the Knickerbocker Motor Truck Mfg. Co., which for several years has made trucks in New York City. H. G. Streat, founder of the Knickerbocker Motor Truck Mfg. Co., is president; A. C. Brady, vice-president and sales manager; H. G. Streat, Jr., treasurer; and W. C. Guilder, formerly production manager Kelly-Springfield Motor Truck Co., designer first Garford trucks and early Macks, and also production man with the Timken-Detroit Axle Co., is production manager. The products will be a 2½-ton truck, a 5½-tonner and a 3-ton tractor. The concern will occupy the old plant of the Knickerbocker company at 151st street and River avenue, Bronx, New York.

Body Builders Briefs

The Turnbull Wagon Co., of Defiance, O., has added a new department and will devote a portion of its plant to the manufacture of motor car bodies.

Michigan Hearse & Motor Co., Grand Rapids, Mich., is building an addition to its plant. The addition is to be 100 x 60 ft., and will be devoted to the construction of bodies.

H. A. DeHart, the well known wagon builder of Thoroughfare, N. J., has commenced the manufacture of motor truck bodies. The addition of this line to the company's product resulted from the quite general use of motor trucks by the farmers in New Jersey.

Sayers & Scovill to Make Autos

The Sayres & Scovill Co., Cincinnati, carriage builder, has increased its capital stock from \$150,000 to \$650,000, and is having plans prepared for a large factory to be erected at Winton place to be devoted to the manufacture of automobiles and special auto trucks. Complete building plans are not yet available. The company's former plant on Colerain avenue was recently destroyed by fire.

Death of Harry D. Johnson, Jr.

Harry D. Johnson, Jr., a prominent member of the executive force of the Studebaker Corporation, died at Epworth Hospital, where he had been ill with typhoid fever for five weeks. As extension work director and master mechanic of the Studebaker Corporation, Mr. Johnson visited the city of Flint, Mich., during the prevalence of a typhoid epidemic and it is presumed he contracted the disease while there. The deceased was the eldest son of Harry D. Johnson, Sr., and Lilia Studebaker Johnson, and was the first grandchild of Mr. and Mrs. J. M. Studebaker, Sr. He was born in South Bend, July 29, 1882, and had spent the greater part of his life in that city. He is survived by his widow and four children, his father, two brothers, and a sister. He was married in 1907 to Miss Elza Lichtenberg, of San Rafael, Cal. In 1906 he became assistant master mechanic of the Studebaker Brothers Manufacturing Co. and eventually became head of the department.

Timken Employes to Operate Store

Employes of the Timken-Detroit Axle Co., Detroit, Mich., plan to reduce the cost of living by the operation of a store owned by themselves. It will be known as the Co-operative Store of the Timken-Detroit Co. and will sell food staples to all employes at the lowest possible prices. L. R. Judson, welfare manager for the company, will supervise it.

Aged Vehicle Man Injured

John H. Baker, 86 years old, veteran carriage manufacturer and senior member of the firm of Baker Brothers, Lexington, Ky., fell and fractured his right hip while getting out of bed and attempting to walk in his sleep. He is in a serious condition at his home. Mr. Baker has been married 60 years.

Saxon Fire Does \$25,000 Damages

Fire at the plant of the Saxon Motor Car Co., Detroit, in November, did damage of about \$25,000 in the receiving department and part of the office building. Production was delayed only about an hour by the blaze.

WANTS

Help and situation wanted advertisements, 1 cent a word; all other advertisements in this department, 5 cents a word; initials and figures count as words. Minimum price, 30 cents for each advertisement.

PATENTS

Patents—H. W. T. Jenner, patent attorney and mechanical expert, 606 F St., Washington, D. C. Established 1883. I make a free examination and report if a patent can be had and exactly what it will cost. Send for circular.

FOR SALE

For Sale—"Motor Body Work for Commercial Cars," a new text book dealing with the construction of all types of bodies for business purposes. Contains also six working drawings and a glossary of technical terms, together with diagrams and sketches. Price, \$1.20 net; by post, \$1.56. Orders should be accompanied by remittance. Cooper's Vehicle Journal, Ltd., 19 Garrick street, Long Acre, London, England.

Index To Advertisers

Acme Die-Casting Corporation.....	37
Anti-Borax Comp. Co.....	Back cover
Barrell Co., Wm. L.....	4
Bliss, E. W. Co.....	3
Bookwalter Wheel Co.....	42
Bradley, C. C., & Son.....	4th cover
Brawley, T. R.....	2
Brennan Motor Mfg. Co.....	43
Cargill Co., The.....	38
Columbus Bolt Works.....	Back cover
Cowles, C., & Co.....	42
Decker, J. C.....	42
Doehler Die-Casting Co.....	37
Dowler, Chas. L.....	42
DuPont Fabrikoid Co.....	40
Eccles, Richard, Co.....	40
Fairfield Rubber Co.....	43
Felton, Sibley & Co., Inc.....	Back cover
Harrison Mfg. Co., The, Inc.....	7
Hoopes Bro. & Darlington.....	43
Hotel Brunswick.....	41
Hotel Cumberland.....	42
Hotel Tuller.....	38
International Rubber Co.....	41
Jenner, H. W. T.....	38
Johnston Paint Co.....	42
Keratol Co., The.....	4
Laidlaw Co., The.....	39
Lumen Bearing Co.....	3
Millersburg Fifth Wheel Co.....	42
Mulholland Co., The.....	42
Murcott-Duden Co., The.....	2
O'Bannon Corporation.....	39
Parrott Varnish Co.....	42
Parsons Mfg. Co.....	38
Payne, E. Scott, Co.....	42
Pierce Co., F. O.....	39
Porter, H. K.....	41
Pressed Steel Co. of New York.....	2
Rome-Turney Radiator Co.....	37
Russell, Burdsall & Ward Bolt & Nut Co.....	41
St. Marys Wheel & Spoke Co.....	2
Sheldon Axle & Spring Co.....	6
Shortsville Wheel Co.....	43
Skinner, J. M., Bending Co., The.....	38
Smith, H. Collier.....	41
Standard Oil Cloth Co., Inc.....	5
Smith Wheel, Inc.....	1
Technical School for Automobile Draftsmen.....	41
West Tire Setter Co.....	43
White-Quehl Mfg. Co.....	42
Wilcox Mfg. Co., D.....	2
Willey Co., C. A.....	42
Williams, J. H., & Co.....	8
Wing, Chas., Co.....	42

ROME-TURNEY

(TRUCK TYPE)

RADIATOR COOLING SECTIONS

ARE INSURED FOR THE LIFE OF THE ENGINES

Built of Seamless Copper, Helical Tubes and Heavy Copper Top and Bottom Plates. They are practically indestructible in normal service.
Every Rome-Turney Truck-Type Radiator Cooling Section is sold with this written guarantee of quality. It is radiator insurance in every sense.

No. _____

"Radiator Insurance"

ROME-TURNEY
RADIATOR COMPANY
of ROME, NEW YORK

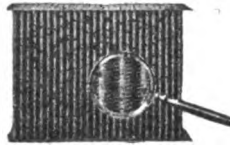

Guarantees

The Seamless Helical Tube Cooling Section Number _____
Installed on _____ ton truck, made by _____

OR THE LIFE OF THE MOTOR NUMBER _____
This guaranty is unreserved, except as against accidental injury
- freezing. If the cooling section develops leaks we will repair
free of charge.

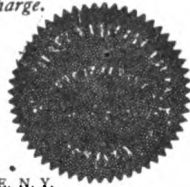

_____ at ROME, N. Y.

_____ day of _____ 19____

W. L. KINGSLEY, President
BARTON HASKLTON, Vice-President
Geo. W. TURNEY, Treasurer-General Manager
W. L. LYNCH, Secretary

Rome-Turney radiator cooling sections are constructed of seamless copper helical tubes, of which we are exclusive makers, and they are designed to exact proportions. The workmanship is as close as that on the highest priced line. The radiating results are absolutely certain and duration is almost unlimited.

Rome-Turney units represent extremely advanced engineering. We have built radiators of all types for 14 years and are specialists in designs developed for truck construction. No better radiators can be built. If this were possible we would build them.

Fulllest Information Will Be Supplied at Request.
Correspondence Is Invited.

ROME-TURNEY RADIATOR CO.
ROME, NEW YORK

1 you write

F. O. PIERCE COMPANY

NEW YORK, U. S. A.

Manufacturers of High Class Pigment Colors

FOR AUTOMOBILE PAINTING

Made from ORIGINAL FORMULAE.
 Colors ground in Japan and other MEDIUMS
 to meet any SYSTEM of APPLICATION

Our Automobile Color Book just issued showing latest shades for this class of work
 mailed upon application

The
Laidlaw Company
 Inc.

New York City

.....

**Automobile
 Fabrics**

.....

**A Fabric for
 Every Purpose
 For Closed, Open or
 Convertible Bodies**



Reg. U. S. Pat. Off.

Moleskin Quality

The Best Leather Substitute

All the
 Standard Leather Grains, Colors and Finishes
GUARANTEED

Against Cracking, Peeling or Wearing Down
 to the Cloth Backing

WRITE FOR SAMPLES

O'BANNON CORPORATION
 200 Fifth Avenue, New York City

High Grade Forgings

for CARRIAGE, WAGON, AUTO-MOBILE and SPECIAL WORK

ECCLES BALL-BEARING COUPLINGS are the BEST on the MARKET for DURABILITY and EASE OF ADJUSTMENT

LEATHER BUSHINGS ARE FASTENED IN THE SOCKET WHERE THEY BELONG

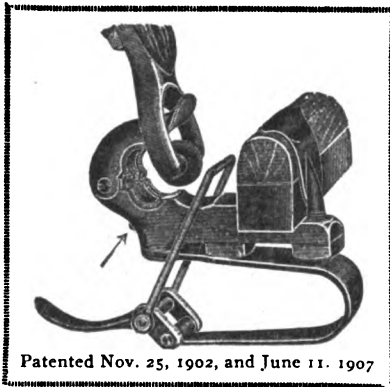

SPECIAL FEATURE—THE SPRING IS PIVOTED AT THE FRONT TO ALLOW EASY ADJUSTMENT

Please bear in mind that we make a FULL LINE of Carriage and Wagon Forgings, also many of those for Auto and Special Work.

Send for our new Catalogs showing our Regular and Special Forgings.

QUALITY GUARANTEED.

SERVICE—THE BEST

Richard Eccles Co.

AUBURN, NEW YORK

CLASSIFIED INDEX

For Addresses See Alphabetical Index and Advertising Pages

AUTO FABRICS

Acme Rubber Mfg. Co., Trenton, N. J.
Barrell, Wm. L., Co., New York
Fairfield Rubber Co., Fairfield, Conn.
International Rubber Co., New York City
Keratol Co., The, Newark, N. J.
Laidlaw Co., Inc., The, New York
O'Bannon Corporation, New York City
Standard Oil Cloth Co., New York City

AXLES (Including Ball and Roller Bearing)

Sheldon Axle & Spring Co., Wilkes-Barre, Pa.

BOLTS AND NUTS

Columbus (O.) Bolt Works Co.
Russell, Burdall & Ward Bolt & Nut Co., Port Chester, N.Y.

BOLT CLIPPERS

Porter, H. K., Everett, Mass.

BRAZING SLEEVES

White-Quehl Mfg. Co., Cincinnati, O.

BRONZE BEARINGS

Lumen Bearing Co., Buffalo.

CLOCKS

Hartford Clock Co., Inc., New York City.

DIES

Bliss Co., E. W., Brooklyn, N.Y. (Sheet Metal Working).

FORGINGS

Eccles, Richard, Auburn, N. Y. (Carriage, Drop).
Williams, J. H., & Co. Brooklyn, N.Y. (Automobile, Drop)

DIE CASTINGS

Acme Die Casting Corp., Brooklyn, N. Y.
Doehler Die Casting Co., Brooklyn, N. Y.

FIFTH WHEELS

Millersburg Fifth Wheel Co., The, Millersburg, Pa.
Wilcox Mfg. Co., D., Mechanicsburg, Pa.

HARDWARE (Carriage, Wagon and Automobile)

Columbus (O.) Bolt Works Co.
Dowler, Chas. L., Philadelphia.
Eccles Co., Richard, Auburn, N. Y.
Wilcox Mfg. Co., D., Mechanicsburg, Pa.
Wing Co., Chas., Amesbury, Mass.
Cowles, C., & Co., New Haven, Conn.
Parsons Mfg. Co., Detroit, Mich.
Payne Co., E. Scott, Baltimore.

LEATHER SUBSTITUTES

Barrell Co., Wm. L., New York.
International Rubber Co., New York City.
Keratol Co., The, Newark, N. J.
O'Bannon Corp., New York.
Standard Oil Cloth Co., New York.
DuPont Fabrikoid Co., Wilmington, Del.

MACHINERY AND TOOLS

Bliss Co., E. W., Brooklyn, N.Y.
Smith, H. Collier, Detroit, Mich.
West Tire Setter Co., Rochester, N. Y.
Williams, J. H., & Co., Brooklyn, N. Y.
White-Quehl Mfg. Co., Cincinnati, O.

MACHINERY (Metal Working)

Bliss Co., E. W., Brooklyn, N.Y.
Smith, H. Collier, Detroit, Mich.
MURCOTT-DUDEN Co., Inc., New York.
Pressed Steel Co. of New York, New York City.

MOTORS

Brennan Motor Mfg. Co. Syracuse, N. Y.

PATENTS

Jenner, H. W. T., Washington, D. C.

PAINTS AND COLORS

Felton, Sibley & Co., Inc., Philadelphia, Pa.
Johnston Paint Co., R. F., Cincinnati, O.
Pierce Co., F. O., New York.
Sherwin-Williams Co., Cleveland, O.
Valentine & Company, 456 4th Ave., New York; 343 S. Dearborn St., Chicago; 74 Pearl St., Boston.
Willey Co., C. A., Hunter's Point, N. Y.

PASTE

Indianapolis (Ind.) Paste Co.

PRESSES

Bliss Co., E. W., Brooklyn, N.Y. (Drop, Power).

RADIATORS

Harrison Mfg. Co., Inc., The, Lockport, N. Y.
Rome-Turney Co., Rome, N. Y.

SCHOOL FOR DRAUGHTSMEN
Mechanics' Institute, New York

SHAFT COUPLINGS

Bradley & Son, C. C., Syracuse, N. Y.
Eccles Co., Richard, Auburn, N. Y.

SPRINGS

Mulholland Co., Dunkirk, N. Y.
Sheldon Axle & Spring Co., Wilkes-Barre, Pa.

THREADS

Meyer, Jno. C. & Co., Lowell, Mass.

TOOLS

Williams, J. H., & Co. Brooklyn, N. Y.

VARNISH AND JAPAN

Felton, Sibley & Co., Inc., Philadelphia, Pa.
Parrott Varnish Co., Bridgeport, Conn.
Pierce Co., F. O., New York.
Sherwin-Williams Co., Cleveland, O.
Valentine & Company, 456 4th Ave., New York; 343 S. Dearborn St., Chicago; 74 Pearl St., Boston.
Willey Co., C. A., Hunter's Point, N. Y.

WELDING COMPOUND

Anti-Borax Compound Co., Ft. Wayne, Ind.

WHEELS

Bookwalter Wheel Co., Miamisburg, O.
Hoopes Bros. & Darlington, Inc., West Chester, Pa.
St. Mary's Wheel & Spoke Co., St. Mary's, O.
Shortsville (N. Y.) Wheel Co.
Smith Wheel, Inc., [Metal], Syracuse, N. Y.
Zwick & Greenwald Wheel Co., Dayton, O.

WOOD BENDINGS, WHEEL STOCK, ETC.

Columbus (O.) Bending Co.
St. Mary's Wheel & Spoke Co., St. Mary's, O.
Skinner Bending Co., J. M., Toledo, O.

DU PONT FABRIKOID

REG. U. S. PAT. OFF.

MOTOR QUALITY

For Carriage Upholstery

With the advancing prices of leather, labor and selling expense, carriage makers have in Motor Quality Fabrikoid a means to decrease upholstery costs without affecting appearance or salability of production.

Motor Quality Fabrikoid

is an improved leather substitute, absolutely waterproof, non-cracking and uniform in quality. Can be obtained in various grains, finishes and weights.

Fairfield Rubber Cloths

in standard weights, duck and drill backings and finishes are now manufactured by us. Solve your upholstery and top material problems by adopting Du Pont Fabrics.

State requirements and samples will be sent promptly.

DuPont Fabrikoid Co.

Wilmington, Del. Toronto, Ont.

FACTORIES:

Newburgh, N. Y. Fairfield, Conn.
Toronto, Ont.

RUSSELL, BURDSALL & WARD BOLT & NUT CO.

Established 1845

PORT CHESTER, N. Y.

MAKERS OF THE CELEBRATED EMPIRE BOLTS AND NUTS

Western Office: Continental & Commercial Bank Bldg., Chicago, Ill. Branch Works: Rock Falls, Ill.

"INTERNATIONAL" RUBBER CARRIAGE CLOTH

The Rubber Carriage Cloth of SERVICE and QUALITY

Write for Samples and Prices

INTERNATIONAL RUBBER CO.

120 Broadway, New York

Vehicle Mechanics

Desiring to improve their present Condition should attend the

TECHNICAL SCHOOL

For

Automobile Draftsmen and Mechanics

Supported by the

The National Automobile Chamber of Commerce, Inc.

The object of the School is to teach men to design vehicles and make working drawings, and to otherwise facilitate their work in the shop. Only those men employed in carriage or automobile building or their accessory trades are admitted to its privileges.

The classes are conducted in three divisions, viz.: Corresponding, Day, and Evening. The former is open during the entire year, while the day and evening classes are in session only from October 1 to April 1.

The tuition is moderate.

For prospectus and full particulars, write to the instructor,

ANDREW F. JOHNSON,

20 West Forty-fourth St.,

NEW YORK CITY

THE BRUNSWICK



Boylston Street, Corner Clarendon,

(Facing Copley Square)

BOSTON - - MASS.

High class modern house, intelligent service, pleasant rooms, superior cuisine.

Ladies traveling alone are assured courteous attention

European plan, single rooms, \$1.50 up; with bath,

\$2 up; double, \$2 up; with bath, \$3 up.

American plan, \$4 per day up.

FRED E. JONES

Proprietor

Results Always Follow
Advertising in
THE HUB

It Pays
Others
It Should
Pay You

"Quickwork"

Sheet Metal Working Machinery

For Automobile and Carriage Bodies, Fenders, Hoods, etc.

H. COLLIER SMITH

807-815 SCOTTEN AVE.

DETROIT, MICH.

PORTER'S BOLT CLIPPERS

"Easy" "New Easy" Allen-Randall



To Cut 5-16, 3-8, 1-2, 5-8, 3-4 Inch.

H. K. PORTER,

EVERETT, MASS.

BUSY BUYERS BRIEFS



Manufacturers
FIFTH WHEELS
All Varieties
Heavy Goods a Specialty
Iron and Steel Rings from 4 to 60 inches wide
MILLERSBURG FIFTH WHEEL CO.
Millersburg, Pa.

WE MANUFACTURE
FINE VEHICLE WHEELS
The Bookwalter Wheel Co.
MIAMISBURG, OHIO

JOHNSTON'S KRAKNO
Color Card Free
\$3.50 per gallon
The R. F. Johnston Paint Co.
Cincinnati, Ohio

THE CHARLES WING CO.
Established 1848
Manufacturers and Wholesale Dealers in
AUTOMOBILE AND CARRIAGE HARDWARE AND TRIMMINGS
AMESBURY, MASS., U. S. A.



The **PARROTT VARNISH CO.**
BRIDGEPORT, CONN.
Automobile, Coach and Wagon
VARNISHES
and VARNISH REMOVER

Why Not Have the Best?

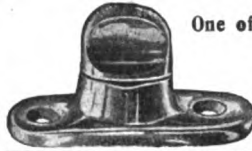

One of a Large Variety
G. Cowles & Co.
NEW HAVEN, CONN.

J. C. DECKER
MONTGOMERY, PA.
Manufacturer of
Carriage, Skate and Pad Straps
Side Loops, Bridle Fronts, Tail Ties, etc.

SUBSCRIBE FOR
THE HUB
\$2 PER YEAR

E. SCOTT PAYNE CO.
Carriage and Automobile
HARDWARE
Horse - Shoers' Supplies
362-364 North Gay St., Baltimore, Md.

CHARLES L. DOWLER
CARRIAGE AND WAGON HARDWARE
108 North Third St., Philadelphia, Pa.
CUSHION MANUFACTURER
Pure Stearic Acid Candles. Wheel Stock. Snow Flake Axle Grease.

MULHOLLAND BUGGY SPRING
Reduces weight of springs one-half.
Made in one size only but will fit bodies of all widths.
Write for further particulars and prices.
THE MULHOLLAND CO. DUNKIRK, N. Y.

White's Brazing Sleeves
For applying Rubber Tires
Send for Samples.
WHITE-QUEHL MFG. CO.
431 E. Pearl St.
CINCINNATI, OHIO

HOTEL CUMBERLAND

NEW YORK

Broadway at 54th Street

Near 50th Street Subway Station and 53d Street L



Broadway Cars from Grand Central Depot.

Seventh Avenue Cars from Pennsylvania Station.

NEW AND FIRE-PROOF

Best Hotel Accommodations in New York at Reasonable Rates.

\$2.50 with Bath and Up

EUROPEAN PLAN

All Hardwood Floors and Oriental Rugs.

Ten Minutes' Walk to 40 Theatres

Excellent Restaurant. Prices Moderate.
Send for Booklet.

HARRY P. STIMSON

Only New York Hotel window-screened throughout

WILLEY'S COLORS

The Recognized Standard



C. A. WILLEY CO.

COLOR GRINDERS

and Manufacturers of Specialties in

CARRIAGE, AUTOMOBILE and CAR

PAINTS

COLORS, VARNISHES, ETC.

HUNTER'S POINT, NEW YORK CITY

Please mention "The Hub" when you write

HOOPES BRO. & DARLINGTON

(INCORPORATED)

WEST CHESTER, PA.

WE ARE MAKING

AUTOMOBILE WHEELS

Forty Years' Experience as WHEEL MAKERS is guarantee we can make good ones.
Will not make any other kind. Try them.

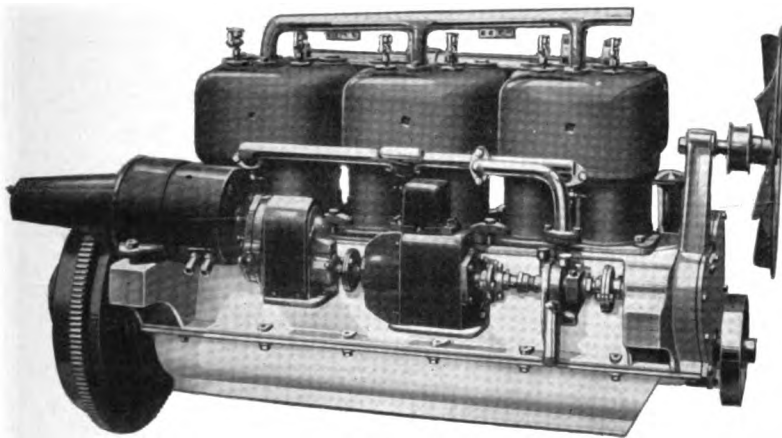

Model 6B Motor, 4½" bore by 5" stroke

Quality and Service

are the two essentials that for 17 years have been built into

BRENNAN STANDARD MOTORS

The manufacturer of Commercial or Pleasure cars who equips his product with Brennan Standard Motors can feel assured his every requirement regarding this vital part has been fulfilled.

Built in the following sizes:

- | | |
|---------------------------|----------------------------|
| 4 Cylinder Model M—4 x 5 | 4 Cylinder Model 12—5½ x 6 |
| 4 Cylinder Model B—4½ x 5 | 4 Cylinder Model 12—6 x 6 |
| 4 Cylinder Model 11—5 x 5 | 6 Cylinder Model 6B—4½ x 5 |

Let us send bulletins telling WHY Brennan Motors are STANDARD motors

Brennan Motor Mfg. Co., Syracuse, N. Y.

THE FAIRFIELD RUBBER COMPANY

Manufacturers of

Carriage Cloth, Imitation Leather,
Automobile Cloths, etc.

FAIRFIELD,

CONNECTICUT

The WEST Hydraulic Tire Setter

WILL CUT DOWN EXPENSE



Tires set cold in one minute. This machine saves time—does the work better and quicker, does a way with burned streaks. Only necessary to measure one wheel in a lot. Does not char the rim, and

thus make the tire loosen prematurely. Saves resandpapering of wheels. This machine is now increasing the profits of many manufacturers. Send for catalog and read about it.

WEST TIRE SETTER CO., ROCHESTER, NEW YORK

Edw. T. Sheffer, Pres. and Treas.

A. R. Brown, Vice-pres. and Supt.

G. E. Godfrey, Sec'y

NEW YEAR'S RESOLUTION

Resolved, That we use during 1917

SHORTSVILLE WHEELS

Make this your New Year's resolution and thus insure success in an important part of your vehicle

SHORTSVILLE WHEEL CO.

"The Daylight Factory"

SHORTSVILLE, N. Y.

The Hub

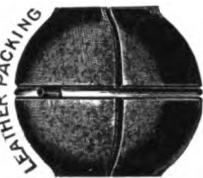

The Only
One-piece
Moulded
Leather Packing

The Bradley Carriage Coupler

All-Steel Noiseless Quick-Shifting Ball-Bearing

(MADE IN FIVE SIZES FOR AXLES 1/4 INCH TO 2 1/4 INCH)

The *only* carriage coupler that is furnished with a ONE-PIECE MOULDED LEATHER PACKING

C. C. BRADLEY & SON, Syracuse, N. Y.



The Bradley Carriage Coupler



PAT. MAY 27, 1904

"E-Z" Welding Compound is the best for general welding.

Because it sticks to the metal at a low heat.

Because it makes perfect welds at fully 250 degrees lower heat than any other.

Because it does not boil up and waste while fluxing.
Because it prevents slipping of laps.



and where parts are fastened together before welding, like Toe Calks, etc.

CRESCENT Welding Compound is the best substitute for borax known. It is particularly good for welding under dies

FOR SALE BY ALL JOBBERS
Samples Sent Free

Manufactured only by

ANTI-BORAX COMPOUND COMPANY, Fort Wayne, Ind.

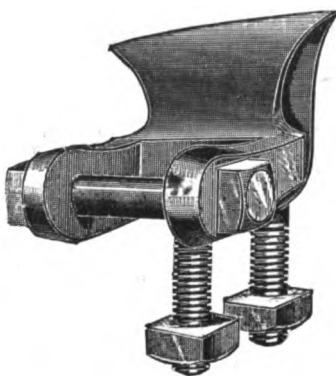

Skewed Shaft Couplings

Regular or Oval Patterns
For High Arched Axles

Furnished in rights and lefts for any height of arch.
Oval Axle Clips 5/8 or 3/4 width to match Oval Couplings. Bolts, Clips, Couplings, Carriage Hardware and Special Forgings

Catalogue "H" and Prices on Application

COLUMBUS BOLT WORKS COMPANY
COLUMBUS, OHIO

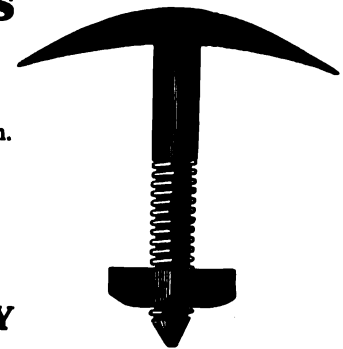

There Is Profit in "F-S" Products

That final touch—the finish—so helpful in selling your products can be assured by using our high-grade Coach, Carriage and Automobile Paints. They are made only of the finest, purest ingredients.

FELTON, SIBLEY & CO., Inc.

Manufacturers of
Colors, Paints and Varnishes since 1863

136-140 North Fourth Street
PHILADELPHIA

Hub

the Vehicle Industry

JANUARY, 1917

No. 10

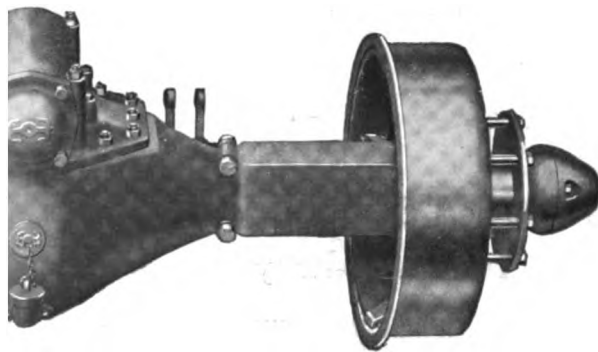

SOUND

Hub Axles Are SOUND Axles

ple.

high quality of their materials.

built to stand up under the rack and grind

the world, and worth all they cost."

Hub Spring Company

Barre, Pa.

PACIFIC INTERNATIONAL EXPOSITION

steel stampings

especially for
COMMERCIAL TRUCKS

The Pressed Steel Co. of N. Y.
141 Broadway



TRUE ECONOMY

One of the right kind of washers will outlast two of the cheap, shoddy kind, but it will not cost twice as much.

If ultimate economy counts for much with you, if quality at a fair price is what you want, then we would welcome the opportunity to demonstrate our ability to deliver the goods.

We manufacture

**FELT AUTOMOBILE WASHERS,
GASKETS AND STRIPS**

for every requirement.

FORD WASHERS and GASKET SETS
for the jobbing trade. "Rounds Brand."

LET US QUOTE ON THAT RUSH ORDER



SEAMLESS TUBING STEEL—BRASS—COPPER

Screw Machine Products
Standard Cap Screws, Nuts, Bolts
U. S. S.-S. A. E. Threads a Specialty
Prompt Deliveries

**Send Us Your Specifications
for Rush Requirements**

MURCOTT-DUDEN CO., Inc.
253 Broadway **New York**



Bliss Power Presses—Standard for 58 Years

When you buy a press, keep this one fact in mind: You are buying for now and for the future.

Machinery is the last thing on which to try to save money. No press can be too good for you—too strong or too serviceable.



Buy Bliss Presses



And make an investment that pays dividends in money saved on power consumption, on repairs and money saved by increased efficiency. You are assured of absolutely steady, reliable service.

There is a Bliss Press to successfully meet every sheet metal working requirement. Write today, advising your requirements.

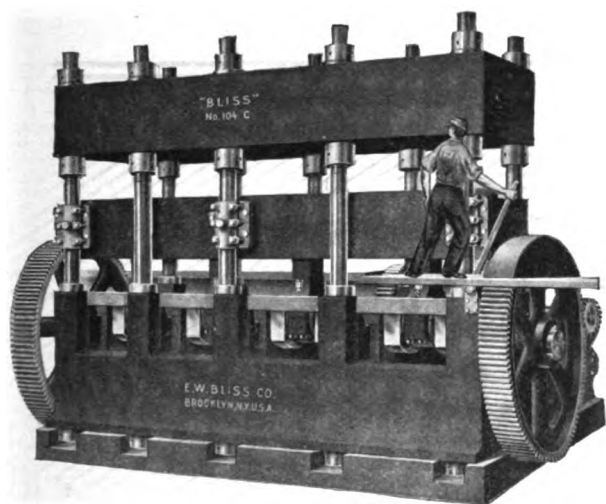

"Bliss" Bottom Slide Multiple-Crank Press No. 104-C. Weight, 140,000 lbs.

Built in a large number of sizes "Bliss" Bottom Slide Multiple Crank Presses are specially designed for forming automobile side frames and cross-rails, steel-car parts, fence posts, channels, angles and miscellaneous heavy forming work of like character.

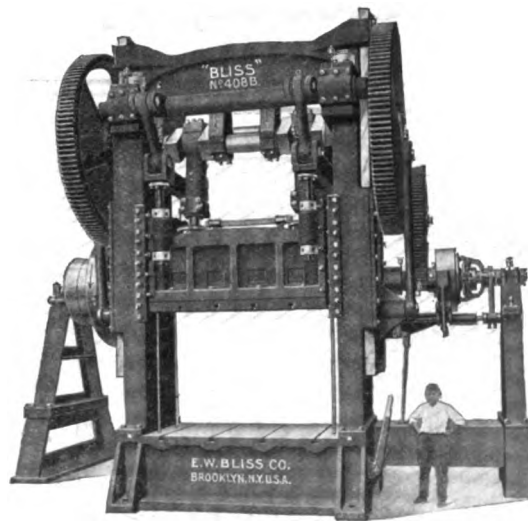

"Bliss" No. 408-B Double-Crank Toggle Drawing Press. Weight, 125,000 lbs.

Built in many sizes "Bliss" Double-Crank Toggle-Drawing Presses are adapted for drawing and forming from heavy stock irregular and oblong shaped articles of large area such as automobile radiators, fenders, running boards, engine pans, gear covers, doors, etc.

"THERE IS A BLISS PRESS FOR EVERY REQUIREMENT"

E. W. BLISS CO., 38 Adams St., Brooklyn, N. Y.

Chicago Office: Peoples Gas Building

Detroit Office: Dime Bank Building

Cleveland Office: Union Bank Building

Please mention "The Hub" when you write

The Caidlaw Company Inc.

New York City

AUTOMOBILE FABRICS

A Fabric For Every Purpose

For Closed, Open or Convertible Bodies

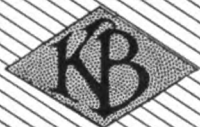

Keratol

TOPS

“THE STANDARD
of the
WORLD”

Write for
Samples

W^m L. BARRELL CO

8 THOMAS ST
NEW YORK

MERITAS LEATHER CLOTH

Get Samples of the Leading Leather Substitute

No scarcity of goods here. We are operating five of the largest plants in this line overtime to keep up with the demand for MERITAS LEATHER CLOTH.

Wise manufacturers by the hundred look upon MERITAS LEATHER CLOTH as the leading leather substitute because it practically duplicates real leather in finish, grain and color. Extremely serviceable under all conditions.

MERITAS LEATHER CLOTH is made in all weights, grains, colors and finishes to meet the various needs of carriage and automobile manufacturers.

Write for samples and learn more about the leading leather substitute.

The trademark is stamped on the back of every piece.

The Standard Oil Cloth Company

INCORPORATED

320 Broadway

New York



PHOTOGRAPH
MOTOR QUALITY
UPHOLSTERY
MATERIAL

**DU PONT
FABRIKOID**

REG. U. S. PAT. OFF.

THE STANDARDIZED
Upholstery and Top Material

DU PONT FABRIKOID, Motor Quality, after three years of service on hundreds of thousands of cars is now used more extensively for automobile upholstery than are the various kinds of leather, cloth or competitive leather substitutes.

This remarkable preference for FABRIKOID, Motor Quality, is a positive endorsement of its superiority and firmly establishes FABRIKOID, Motor Quality, as the standardized automobile upholstery material.

RAYNTITE TOP MATERIAL

is as supreme in its special field as is its kindred product—FABRIKOID, Motor Quality. RAYNTITE is guaranteed against leaking for one year, but its durability assures years of service. It is made in two varieties:

RAYNTITE No. 1—Single Texture with Fabrikoid Surface;
RAYNTITE No. 2—Single Texture with Fairfield Rubber Surface.

Both of these RAYNTITE fabrics are guaranteed by a company whose integrity of purpose and financial responsibility are universally recognized.

FABRIKOID, Motor Quality, and RAYNTITE are nationally and constantly advertised. Prospective purchasers of automobiles and vehicles of all types are acquainted with the merits of these standardized materials and will demand upholstery and tops of FABRIKOID.

Adopt FABRIKOID, Motor Quality, and RAYNTITE—the standardized upholstery and topping fabrics for automobiles, motor trucks and vehicles of every class. Ask for samples showing weights, grains, backings, and finish available. Get acquainted—write today.

Du Pont Fabrikoid Co.

Wilmington, Del. Toronto, Ont.

Factories: Newburgh, N. Y.

Fairfield, Conn. Toronto, Ont.,

PHOTOGRAPH
OF RAYNTITE
TOP MATERIAL



Main Works of Fabrikoid Co., Newburgh, N. Y.



DROP FORGING PROGRESS REFLECTS

CRYSTALLIZED THOUGHT SPECIALIZED STUDY
VITALIZED ACHIEVEMENT

Dependable Drop-Forged Parts—Levers, Clevises, Tappets,
Rockers, Special Rod and Yoke Ends.

Parts for Starters, Lighters, Electrical Devices, Shock
Absorbers, Accessories.

If you want early delivery, send us your speci-
fications for small and medium-sized drop-forgings.

Its "standard bearers" anticipated exacting requirements and measured their product in terms of quality alone. Time and experience have confirmed their judgment. Only in rare cases now can weaker substitutes be used in place of

"SUPERIOR DROP FORGINGS"

of "Grand Prize" calibre. We specialize in the careful forging and proper heat-treating of all alloy materials. We possess the necessary facilities and experience in chemical and physical laboratories to develop the maximum in strength and durability with the minimum of size, weight and form.

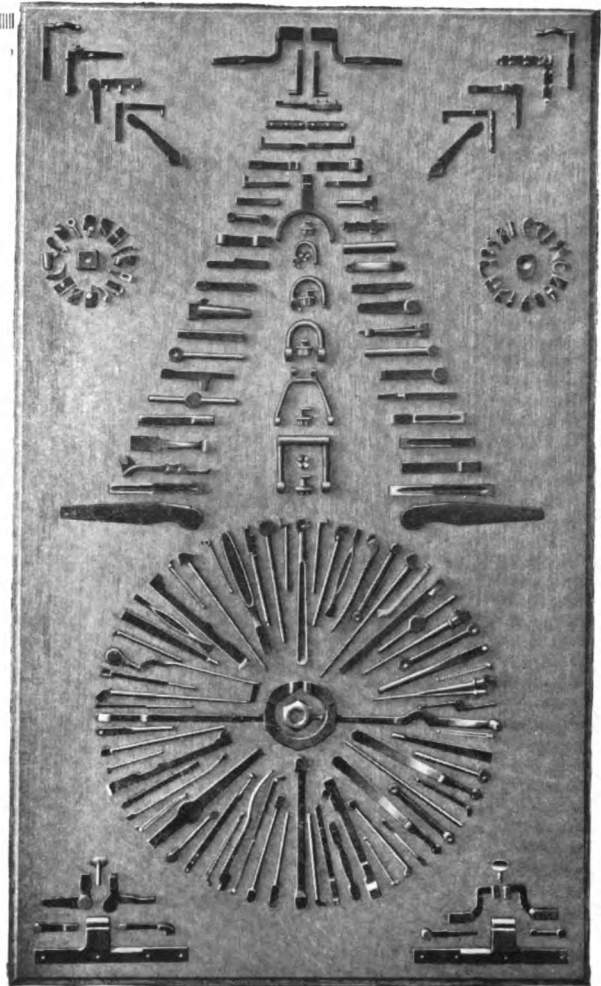
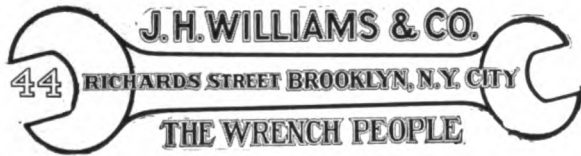

Gear
Bronze
Phosphor
Bronze
Manganese
Bronze
Die Castings

*A sufficient variety of
Bronze Alloys
to cover all requirements
Special Alloys Made to
Specifications*

Booklets gladly furnished

Lumen
Bronze
Machine
Bronze
Babbitts
Solders

The Bronze Castings which we make are manufactured under strict laboratory supervision and are subjected to rigid inspection

LUMEN BEARING COMPANY

BUFFALO

The Hub

Vol. LVIII

NEW YORK, JANUARY, 1917

No. 10

Published Monthly by

THE TRADE NEWS PUBLISHING CO. OF N. Y.

PAUL MORSE RICHARDS, *President* G. A. TANNER, *Secretary and Treasurer*
EDISON BUILDING, COR. ELM AND DUANE STS., NEW YORK

THE HUB, a monthly authoritative journal on all subjects pertaining to the vehicle industry from its engineering and construction viewpoints. It publishes information of live interest to manufacturers of motor vehicles, trailers, carriages, wagons, the accessory trades, repair shops and garages.

Subscription price for the United States, Mexico, Cuba, Porto Rico, Guam, the Philippines, and the Hawaiian Islands, \$2.00; Canada, \$2.50; payable strictly in advance. Single copies, 25 cents. Remittances at risk of subscriber, unless by registered letter, or by draft, check, express or post-office order, payable to the order of THE TRADE NEWS PUBLISHING Co.

For advertising rates apply to the publishers. Advertisements must be acceptable to publishers. Copy for new advertisements must be received by the 25th of the preceding month. All communications must be accompanied by the full name and address of writer.

Entered in the New York Post Office as Second-class Matter

The National Automobile Show

Approximately 400 automobiles of various types and 400 tons of accessories that add to serviceability, comfort and elegance, greeted the view of the thousands who visited the 17th annual exhibition of the National Automobile Show in Grand Central Palace.

While there are no radical departures seen, the automobile of 1917 is far ahead of the automobile a year ago. The outlook for 1917 is most encouraging. The automobile manufacturer has evidently arrived close to the point of perfection in engine designing. Efforts seem to be directed toward ridding the motor of unnecessary parts, strengthening up the running gear, reinforcing fore construction and steering gear and developing exquisite bodies of almost countless styles. Beautifully upholstered limousines that are far finer than the drawing rooms of private railroad cars were seen in large numbers. Some of the finest closed vehicles cost as much as \$10,000, while others sell for as low as \$395. And in either case the buyer gets superb value for his money.

The six-cylinder types seem to be holding their own, for while its percentage is slightly lower than for 1915, it is higher than for 1916. The sum total of the percentages of eight and twelve-cylinder models is about the same as it was last year. The trend toward smaller cylinders continues. Practically 50 per cent of all the motors now have a cylinder bore of less than $3\frac{1}{2}$ in., while a year ago the percentage was only 37 and the year before that only 10 per cent. Casting all the cylinders in a single block is now the accepted practice in four-cylinder engines and is rapidly approaching the universal point in six-cylinder construction.

Rather a remarkable feature of the automobiles displayed is that although the price of practically everything

that goes into the making of an automobile has gone up, only a few of the manufacturers have increased the price of their product for the coming season. Generally the prices are only slightly higher than they were a year ago, and when compared with almost every other thing sold today, much cheaper than a few years back.

The return of the steam car, as exemplified in the Doble, drew large crowds. It is the first steam automobile that has been displayed in years.

According to the monthly report of the Public Employment Bureau, the number of immigrants coming to this country last year from Great Britain and France was as large as in normal peace years. The fact has an interest as respects war conditions of immigration, and certainly it has an important interest as relates to the possible effect on these conditions of a declaration of peace.

Automobile manufacturers are consoling themselves that there is no danger of their reaching the "saturation point" for a long time. When there are 3,500,000 farms in the United States and wheat hovers near \$2 a bushel and eggs 5 cents apiece, why should they give way to pessimistic doubts?

The Department of Agriculture reports that the American farm output in 1916 was valued at \$13,449,000,000, which compares favorably with some of the European war budgets.

Wages in New Zealand

The New Zealand Federated Coachmakers' and Wheelwrights' Industrial Association of Workers have lodged a fresh claim on employers. Among other things asked for are: A 44-hour week; a minimum rate of 1s. 6d. per hour for all branches, leading hands in each case to receive $1\frac{1}{2}$ d. per hour extra; one apprentice to three journeymen; week's notice of termination of engagement; 1s. 6d. extra to each workman per week for the use of his tools.

Leather From Japan

According to the Shoe and Leather Record, a correspondent of the Associated Press who has recently visited the Russian front expresses his astonishment at the extent to which Japan has supplied Russian troops with equipment. "Not only their clothing," he says, "was made in Japan, but their leather belts and the stout hob-nailed shoes are made in Japan from hides gathered in Korea, which is proving a vast reservoir of raw hides which the Japanese are turning into boots, saddles and leather furnishings."

Seventeenth Annual Automobile Show

Production Passes the Million Mark—Tendencies in Body Design One of the Show's Principal Features

Without a doubt the 1917 automobile show, held at Grand Central Palace, New York, from January 6 to 13, was the greatest event of its kind ever witnessed by an automobile-loving public. Some thirty-odd new manufacturers have entered the field during the past year, and there were cars of every description, as well as of a large range of prices, calculated to meet the increasing demand for the self-propelled vehicle. A visitor to the show could find much of interest and value also in the unusually large number of accessories and parts presented to view. In fact, aside from a direct interest in any special type of car, there was much to see that all motor car owners, and prospective owners, no doubt found of an enlightening and instructive nature.

More than ever before, the various types of body design and construction were of interest, and it may well be said that considerable progress has been made toward evolving suitable types for almost every conceivable purpose. The 16 types of bodies not long ago defined by the S. A. E. will no doubt each find a place of greater or lesser importance, though the tendency at this time seems to be toward the design of a body that will serve efficiently as a truly all the year type. This style of body has been growing in favor during the past two years and much progress has been made toward evolving a satisfactory design. What is known as the "open sedan" seems at present to be the design that induces the most satisfactory criticism, and this type has been adopted by a number of makers during the past year.

Next to the open sedan the two or three-seated car with collapsible top, the coupelet, or with detachable top, the convertible coupe, will in all likelihood be found to hold second place in the season's tendency in body styles. The roadsters of clover-leaf and club type, also occupy a more prominent place than ever before. The year's production of roadsters in comparison with the touring car is not known, but if it were it would undoubtedly show a strong relative gain. The compactness of the roadster with, at the same time, provision for roominess, has had a decided appeal, and the ingenuity exhibited in adding to the number of seats in the roadster has been one of the most interesting developments in recent body design.

The popularity of the roadster type has made itself felt in the makes of the highest priced cars and one can go as high as he likes in selecting a car with seats for but two persons, say. In fact, lessened seating capacity, that is, doing away with surplus room, seldom if ever used, is a noteworthy tendency in 1917 automobile design. This, too, irrespective of price. Some of the most costly town cars in new models seat but two or three persons.

There seems to be a tendency toward smaller bodies generally, and the lines are so drawn as to more noticeably emphasize the chassis, a detail of construction that is of no little importance, due to the fact that there is a very close relation between the body and the chassis. This is a feature worthy of particular attention for manufacturers, and of peculiar interest to the buyer of a car; albeit the average purchaser is not aware, always, of just how much such a matter bears on his decision in choosing a car.

The convertible idea, too, has affected the highest priced cars, showing how full of life this idea is. In some of the

custom-made bodies of the season, in which the cost was but a secondary consideration, the space between the chauffeur and the owner is no longer sharply divided. The glass window behind the driver's seat is made so that it may be lowered, and in the Berline type the whole car may thus be thrown into one compartment. This elasticity is at the owner's behest; if he desires to drive he may do so without submitting to the isolation of the typical chauffeur seat.

Mechanically there has been not a great deal of change in the majority of makes of cars. The number of cylinders best suited to the modern motor car power plant is still a much debated question. So far the "fours" have shown the greatest gain, among both new and old makes. In all types, however, the tendency is toward a smaller bore, longer stroke, and lighter weight motor, and a continued increase in the building of high-speed engines. The latest feature of design among the "four" is a new 16-valve motor, calculated to give a degree of flexibility to the engine hitherto unattained. Much interest is expressed over the results. The greater flexibility of the high-speed type of motor has led to the displacement of four-speed gear boxes almost entirely, and the adoption of three-speed gears. Another tendency in motor design is toward the construction of engines with removable cylinder heads, and an increasing popularity of overhead valve design has been noted. The vacuum fuel feed system is now almost universal among American car makers.

It is said that the automobile has resisted the tendency toward higher prices rather better than a great many other manufactured articles and this probably accounts for the wonderful record of sales during the past year. Four and six-cylinder cars lead all others, there being 133 companies building these types, some 58 making only fours and 43 building only sixes.

The average price of passenger cars sold during 1916 figures out at almost exactly \$600. This would seem to demonstrate the fact, frequently stated, that the automobile is now within the reach of almost any man's pocket-book, and it augurs well for the industry as a whole. Advances in prices have been made during the year past, by many car builders, but notwithstanding, the average increase has been a small one. The past year has been a phenomenal one in the history of the automobile industry, and it is not generally expected that 1917 will be productive of such extraordinary increases in either production or sales, though it is anticipated by some that a production increase of about one-fifth over 1916 may be expected during the present year.

Cincinnati Carriage Club Celebration

The thirtieth annual dinner of the Cincinnati Carriage Makers' Club was held at the Hotel Gibson on the evening of December 21, with Theodore Luth, of Cincinnati, president of the Carriage Builders' National Association, as the principal speaker. For the first time in the history of the organization ladies were among those present. A big tree was a decorative feature. Dancing followed the dinner.

President Charles A. Fisher presided at the dinner, and introduced the speakers. The entertainment committee consisted of Howard S. Cox, chairman, Charles W. Steele, E. G. Schick, I. O. Bauer, Ralph Rowalt and W. J. R. Alexander. A musical and literary entertainment program was a part of the evening's festivities.

Studebaker's Annual "Golden" Sensation

Last year Studebaker startled New Yorkers with the famous "gold chassis." This year it was the "gold car," an evolution even more magnificent than the golden chassis.

It is a Series 18 six-cylinder seven-passenger touring car, with the distinctive Victoria top in place. About 400 ounces of 24-karat gold were used in finishing the "gold car," and it is valued at more than \$30,000.

The entire chassis is finished in 24-karat gold just as it was last year; but mounted on this is a standard touring body, also finished in gold and white enamel. The Victoria top is of white leather. The brackets supporting this top are all gold plated.

The white enamel body finish is enriched with hairline stripings of gold. The lamp rim and reflectors, the bars supporting the lamps, the radiator, the springs, the hubs, rims and nuts on the wheels of the car, all are of 24-karat gold.

All fixtures, such as door openers, little fasteners that hold the side curtains, screw heads and bolts, are of gold. The top of the running board and all bolts connecting the fenders are of gold. Gold finishes the steering wheel column and all metal parts, the brackets holding spare tire and rim, the top arms, in fact, every metal part of the car.

The genuine white leather with which the car is upholstered throughout harmonizes with the gold finish. The arm-chair auxiliary seats are upholstered with the same white leather, with all of the fixtures finished in gold. The floor board in driver's compartment is covered with white linoleum and trimmed with gold. Even the speedometer has a white face with gold numbers.

It is stock and standard in every detail, except for its finish of white enamel and gold.

The Studebaker gold car was exhibited for the first time at the New York show, and occupied the place of honor in the Studebaker booth.

Traffic Laws to Be Made Clearer

New uniform motor vehicle and traffic laws will be promulgated in a short time by the legislative board of the A. A. A. The motor vehicle laws now on the statute books of most of the states are unnecessarily long and cumbersome. Duplication and further confusion exists where a state has separate motor vehicle and traffic laws on its books.

"Highway traffic in its final analysis is but a single problem," says Chairman O. I. Yellott, "whether it relates to motor cars, horse-drawn vehicles, traction engines, or pedestrians. Traffic should be handled as one problem by one general set of laws, so that the rules governing one particular kind of traffic may fit into and be consistent with those governing all other kinds of traffic.

"The details of the uniform law to be framed by the A. A. A. board have not yet been fully worked out, but it may be stated in a general way that the first sub-division will deal with general provisions relating to the applicability of the law and definitions of terms used therein. The second sub-division will deal with the appointment, powers, and duties of a state traffic commissioner, who will have general supervision of traffic of all kinds on the public highways. The third sub-division will deal with the registration of motor vehicles and operators. The fourth will deal with the operation of vehicles of all kinds on the public highways, as well as with the conduct of

pedestrians thereon. The fifth will deal with the enforcement of the preceding provisions.

"Thus each sub-division of the proposed law will be almost wholly self-contained, thereby doing away with a great deal of the confusion which now exists in so many state laws by reason of different kinds of provisions being intermingled. But the idea of simplification will be carried still further. The provisions relating to the traffic commissioner will be made quite brief and very simple. One section will define his duties; another, his powers; both in like general terms. Broad provisions will be used to extend these duties and powers as far as may be necessary to accomplish the general objects of his appointment. The courts, as a rule, may safely be trusted to amplify provisions of this kind with much more satisfactory results than where the law maker himself attempts to enumerate all such duties and powers in great detail."

Registration Fee for Trailers

An opinion given by Attorney-General Hinman of Connecticut has resulted in the automobile department of that state requiring a separate license for all trailers, whether of two or four wheels.

A Ford owner recently applying for a license wanted to include his two-wheel trailer in the registry fee of \$11, but Chief Clerk Wetstine informed him that an additional fee of \$15 would be required for the trailer, which would have to have a separate license.

In Mr. Hinman's opinion, when a truck, detachable from either truck or pleasure car, was attached to a truck the carrying capacity of both trucks should be added and taxed according to the total capacity of both.

Important Items in 1916 Auto Production Compared With 1915

The two commanding achievements of the automobile industry in 1916 were that car production passed the 1,000,000 mark and that the total value of motor vehicle production entered the billion dollar class. Chief items of 1916 compared with the preceding year are:

Motor vehicle production for 1916.....	1,617,708
Motor vehicle production for 1915.....	892,618
Passenger cars sold in 1916.....	1,525,578
Passenger cars sold in 1915.....	842,249
Motor trucks sold in 1916.....	92,130
Motor trucks sold in 1915.....	50,369
Retail value motor vehicles sold in 1916..	\$1,088,028,273
Retail value motor vehicles sold in 1915..	691,778,950
Retail value passenger cars sold in 1916..	921,378,000
Retail value passenger cars sold in 1915..	565,856,450
Retail value motor trucks sold in 1916..	166,650,273
Retail value motor trucks sold in 1915..	125,922,500
Average retail price pass. cars in 1916	605
Average retail price pass. cars in 1915	672
Cars and trucks exp. first 10 mos., 1916	67,616
Cars and trucks exp. first 10 mos., 1915	53,380
Value of cars and trucks exported first 10 months, 1916.....	\$100,147,636
Value of cars and trucks exported first 10 months, 1915.....	94,434,432

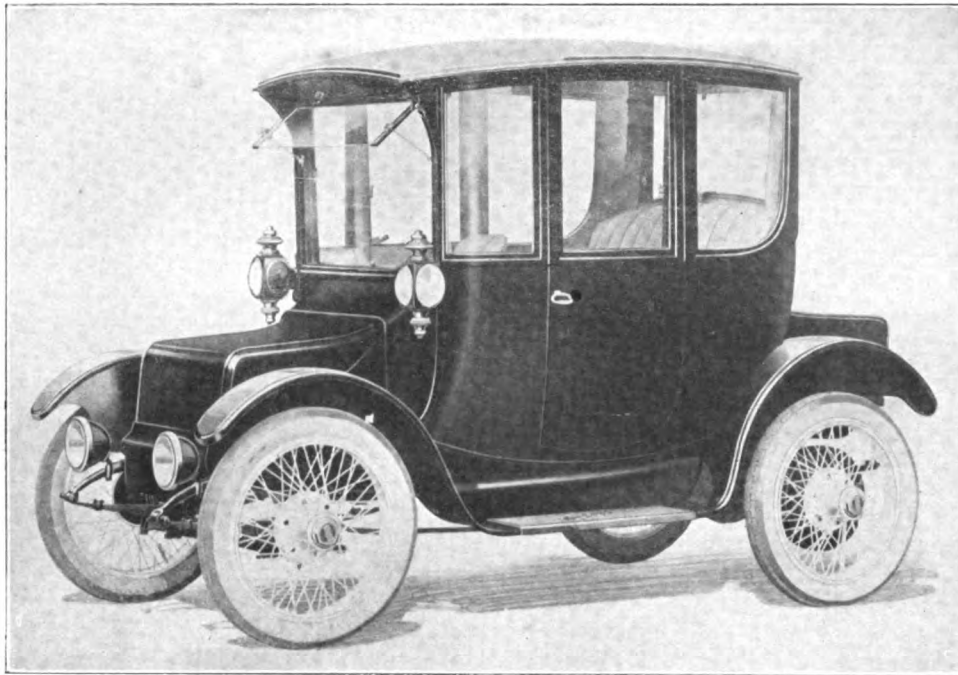

ELECTRIC BROUGHAM
Manufactured by
Baker R. & L. Co., Cleveland, O.

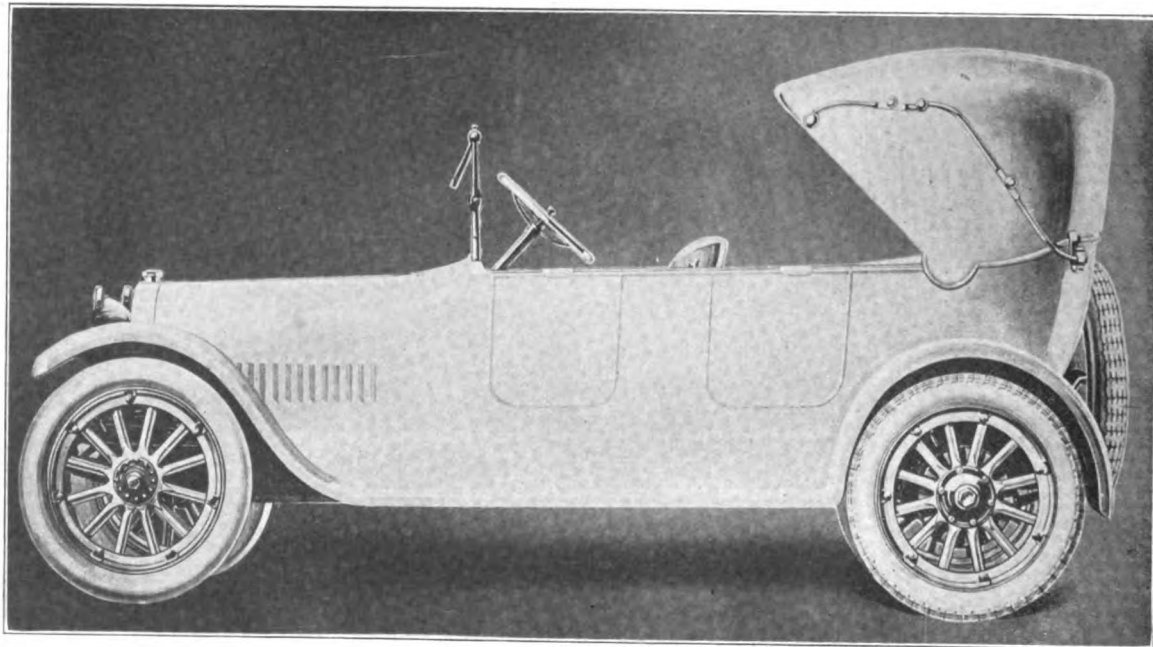

THE GOLD CAR
Manufactured by
Studebaker Corporation
(See article on page 11)

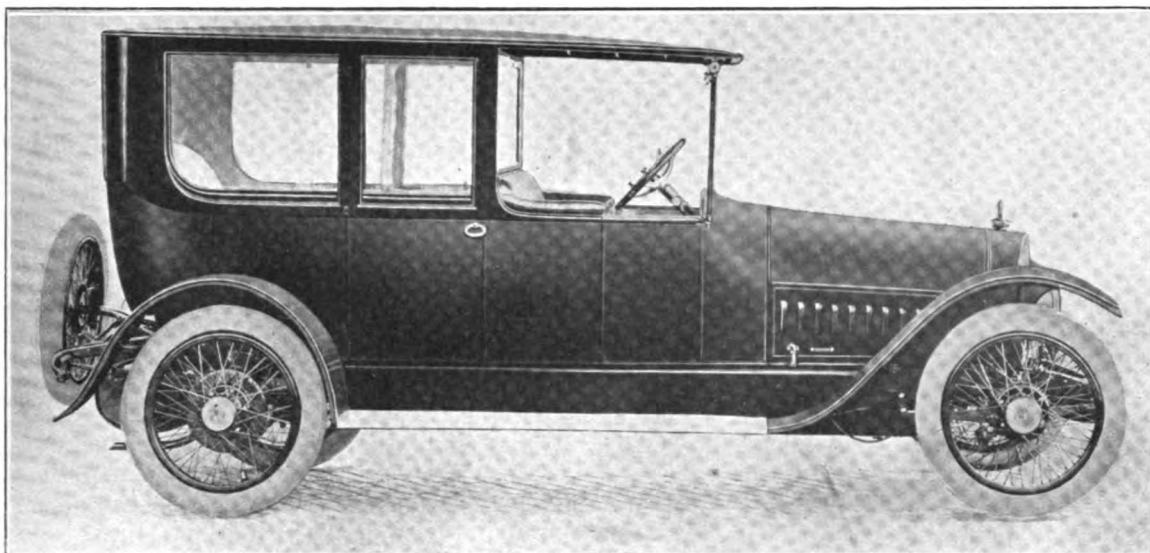

OWEN MAGNETIC LIMOUSINE
Manufactured by
Baker R. & L. Co., Cleveland, O.

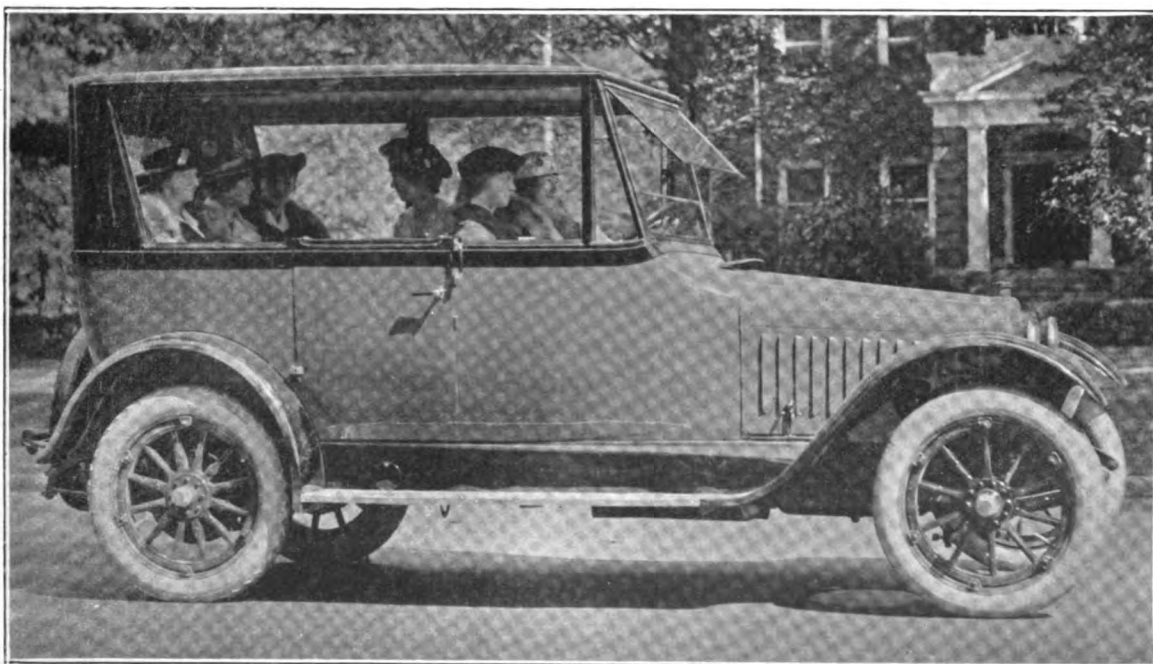

SIX-PASSENGER TOURING SEDAN
Manufactured by
Chalmers Motor Co., Detroit, Mich.

Thirteenth Annual Automobile Salon at New York

The thirteenth annual exhibition of the salon was held at the Hotel Astor, New York, during the week of January 2. It has been reported that the sales made at this year's event were greater than ever, a fact accounted for by many by the statement that large war profits have created a wider field of buyers for the high quality and high priced cars which are the feature of these exhibitions.

The hundreds of patrons of this display of the best of everything in the way of quality, workmanship, design and finish, found particular interest in the coach work, or body construction, of the various cars shown. Not only has the salon presented all of the principal developments and improvements in the matter of motors, drives, wheels, and mechanical elements of design in relation to chassis construction in past exhibits, but with the increasing standardization of such features, the subject of body building has received perhaps more than its customary amount of attention.

The coach work exhibited in the salon showed a marked tendency toward low suspended bodies, for the purpose of giving a finer appearance to motor cars de luxe. A studied effort for simplicity was manifest in a more harmonious blending of colors and unusually exacting attention to details. The requisites of the smart car may be described as low, compact body lines, long sweeping lines of hood and cowl, upholstery of fine texture, neutral colored fabrics and painting of soft, rich colors.

The average price of the cars shown, which run from \$2,000 up, was estimated to be \$5,000, making a total value for the exhibit nearly half a million dollars. The average price of the cars in the Rolls-Royce division was about \$13,000, and the average for the Simplex, Lancia, Singer, White, and Locomobile exhibits somewhat less.

One design, a three-passenger car, was built along nautical lines, noticeable for the rather wide freeboard and fairly flat rear deck like a hydroplane. These lines were emphasized by an unusual painting scheme in which two tones of gray were used—a dark gray on all upper parts and a light gray on sides and understructure. The car appeared extremely low and rakish in all its lines. The two forward seats were divided, giving access to the rear seat. A special design of top, full width in front and narrowing at the rear, was made to fit closely about the rear seat. It appeared very similar to the tops used on speed boats.

Runabout or roadster design has undergone a complete change this season, and the trend is quite distinctly in the direction of four-passenger cars with closely coupled seats. The front seats are usually divided by an aisle, and the rear section has doors on both sides. The rear seat back may be pulled forward, thus giving access to storage space under the rear deck. One such car was painted a torpedo gray and another was finished in peacock blue green.

Coupe design, also, has been subjected to a change, the White coupe, for instance, combines the clover leaf arrangement of seats with a rigid body of the coupe type. A pointed front is also a new feature of the body, and the windshield appeared almost V-shaped, which gives a wide range of vision and eliminates reflection in the glass. Large window areas were also a feature. Two cars of this type were shown by the White company, both having bodies by Rubay, one painted in beaver brown, with gold

brown tapestry, and the other finished in palmetto green, with figured tapestry and two tone green head lining.

The larger coach cars, such as the limousine and landaulet, showed a form and finish markedly different from the models of previous years; a decided trend away from the sheer, flush-sided design which has been a feature of nearly all enclosed car bodies for several seasons. Limousines and landaulets now frequently have removable roof extensions, which when not carried make a notable difference in the appearance of the cars. A roller curtain is provided for protection from sudden weather changes. This is concealed in the front wall and may be pulled forward and attached to the top of the windshield.

There are also pillars of full height clearly defining the passenger section and giving relief to the large side areas. Moldings have been used sparingly, but those few noticed have been designed to accentuate the special characteristics of each individual type. Individuality is also obtained by use of a graceful fillet, marking the back of the driver's seat. As to color finishes in general, it may be said that green, blue, gray and brown seemed to predominate. Of 14 cars shown in one exhibit, five were of distinct shades of green and five totally different interior treatments.

This 1917 salon is considered to have advanced American coach builders to a new place in international competition, and it is believed that it will insure for the future a recognition of high grade American not hitherto granted by European builders.

The makes of cars exhibited this year included the Brewster, Daniels, F.I.A.T., Isotta-Fraschini, Biddle, Lancia, Locomobile, Murray, Phianna, Roamer, Novara, Rolls-Royce, S-S-C, Simplex-Crane, Singer and White, and custom coach work was exhibited by Holbrook, Brewster, Locke and Rubay.

While the Rolls-Royce and Lancia cars were classed as foreign exhibits, the bodies and finish were the work of American body builders, the Fleetwood (Pa.) Metal Body Co. and the Holbrook Co., New York, contributing to that end.

In addition to the Lancia, the Holbrook Co. also built bodies for the Locomobile, Simplex, Singer, Phianna and Crane.

The Rubay Co., body builders, Cleveland, O., exhibited their individuality in the bodies for Locomobile, Murray and White chassis.

The sales at this year's salon are said to have amounted to over \$500,000, and the attendance was stated to be 50 per cent greater than any previous year.

Newark Auto Show

Motor trucks and commercial delivery wagons will occupy a large section of the Newark (N. J.) annual auto show, which will be held in the First Regiment Armory, February 17 to 24. The south and west ends of the main floor of the big drill shed will be given over to the truck section, and the display will be a representative one. Manager Claude E. Holgate has the entries of a dozen trucks already. Newark is a large manufacturing and commercial center, and the truck and delivery wagon is a popular vehicle. Outside dealers as well as Newark motor trucks are permitted to enter the show, and the same rule applies to dealers in pleasure cars, motorcycles and accessories. The final day for space applications is January 25, at the show offices, 520 Broad street.

Progressive Production in Packard Plant

How the Factory Output Has Been Trebled by a Processional Power Stream From Which Flows Finished Cars

The Packard factory, a little more than a year ago, was called on to double and treble production, and at the same time to maintain and better Packard standards. By virtue of careful planning, astonishing expansion in plant and in numbers employed, installation of huge and costly equipment and fixtures and machinery and tools, the production which was set out for is attained.

Two years ago the Packard factory turned out a comparatively small number of cars and trucks, whether output be gauged by year or day. Inside the offices and shops, these men were building a few cars and trucks the very best they knew. They worked rather slowly, and sometimes clumsily and wastefully—as all of them today admit. They pushed heavy motor-laden jacks around by hand; they trucked rear axles and transmissions by hand, all over the lot; they staggered about with their hands full of cylinder blocks; they carried stock hither and yon—and usually when stock was needed hither it happened to be yon.

But all the while, resources were being amassed and plans laid for marked development. The men who comprehended large scale production had been gathered, and, some for as long as nine years, had been addressing themselves to the coming transformation.

Two influences, following in quick succession, threw the opportunity wide open. One was the reaction of both domestic and export trade to the effect of the European war. The other was the response to the appeal made by a new invention in automobile engines—the Packard twin six.

The truck plant felt the first. Within 60 days after the opening of the European war there was insistent demand, both at home and abroad, for freighters. This demand was to mount with the generally increasing business of America, and to be stimulated by the feverish activity of the days when trouble broke out on the Mexican border. The truck factory immediately began to put itself in order for larger production. Orders were expected for it, and confidently, but even the most optimistic were somewhat dumfounded at the greeting received by the new car. There was an inrush of orders.

The men who had been planning systems within systems and organizations of organizations moved forward quietly and speedily to make a different factory. F. F. Beall, vice-president of manufacturing, a large, sandy, unruffled man, who had grown up in large scale manufacture of instruments of precision, administered the broad plan of the transformation. E. F. Roberts, factory superintendent, a gingery, peppery, dark little man of action, executed the plan, performing the Herculean labors of the actual installation. A staff and line of intense enthusiasts on detail fitted the new systems of apparatus to the shop—and as

often fitted the shops to the apparatus—and exemplified for foremen and operatives the new way of doing things.

The elements of truck manufacturing still remaining in the motor carriage plant were removed to the enlarged truck shops. D. G. Stanbrough was made presiding genius of the truck factory. Additions sprang up on every available piece of ground. Machines and tools were added. New departments and new divisions were organized for finer specialization.

A new and complete wheel shop, 283 feet in length, was erected and put in operation in the last year.

The increased production schedule and the wider range of body styles call for bigger and better facilities for body building. And so two new five-story buildings—models, by the way, of factory housing construction—were erected. The larger is 322 feet long. Also a body panelling building, erected in a court, with skylight roof was provided.

These are very much in use. The body panelling department rivals the forge with its great hammers, for noise making. One of those hammering machines, pounding on a sheet of aluminum that requires three or four men to handle, produces much more noise than one ever would believe it capable of.

Body panels, metal parts for running boards, and dozens of smaller parts are sawed, pounded and stamped out in this building. Then there is a great body frame erecting department, where the coachmakers join the sturdy pieces of selected ash and make them form the skeleton of brougham, landaulet, coupe or limousine. In another department the aluminum panels are fitted. In another section, the metal is sand-blasted—roughened by sand under compressed air—so that the priming coat of paint will adhere to the body. Then come the upholstery and painting departments. There you have it—from wood parts

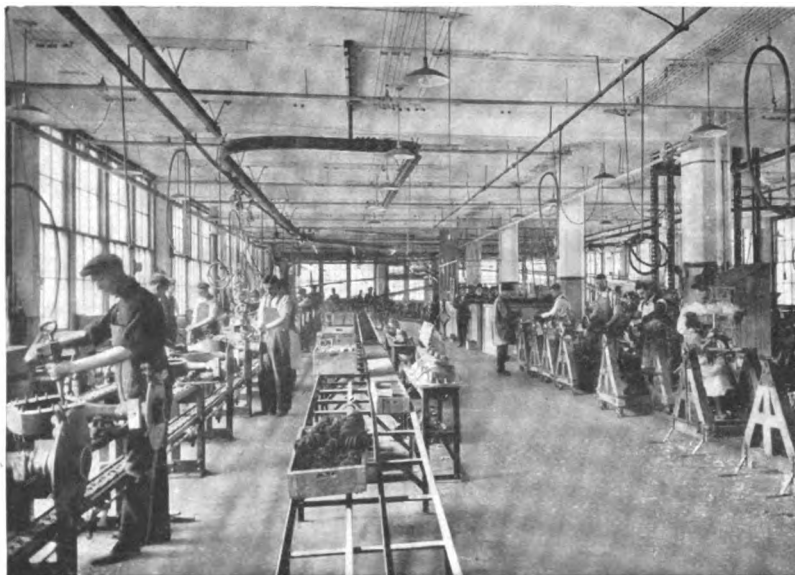

Railway, sloping from ceiling to floor, conveying axle and transmission

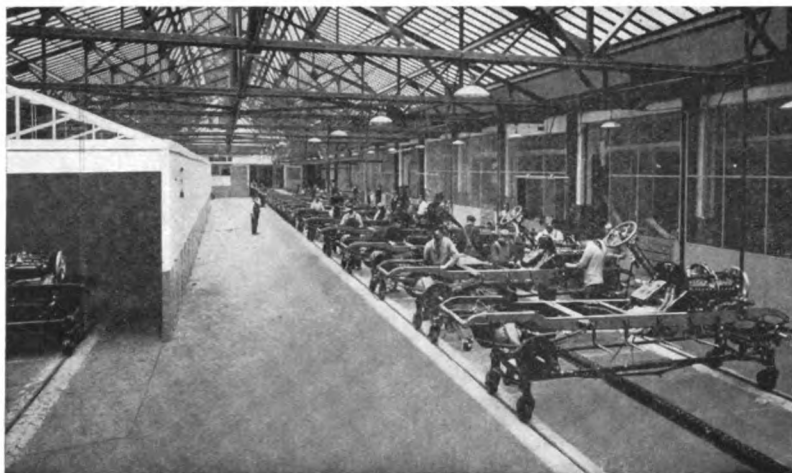

Chassis acquiring various elements from running board braces to steering column and motor as it slips toward paint spray and drying oven

and sheet metal to finished bodies all in one building.

They are large buildings but every foot of space in them is in use. So is every foot in the new five-story building for gear, tool, special paint and finishing departments; in the enlarged service building; and in the 14 dry kilns, where carefully selected woods are super-seasoned to make them fit for wheels and bodies.

Among the other structures put into use in the last year were two truck assembly and machine buildings; four buildings to house truck blacksmith shops and truck frame departments; a building for truck motor jacking and dynamometer tests; iron and aluminum molding rooms added to the foundry, together with a pattern shop; a north power house addition; an addition to the forge to house four new power hammers; an addition to the forge for the stamping department; two courts made into finishing rooms; a third floor addition to the sheet metal and machine repairs building; a third floor addition to the heat-treating plant—used as a hardening room; fifth floor addition to the office building to be used as a photograph gallery and motion picture laboratory.

Under construction are a traffic garage, one story; two wings to the stock building, each six stories; fourth story additions to two service buildings; lumber storage sheds; finished truck storage building and an addition to the main power house.

While the new methods were being installed, production already achieved must not be disrupted, these factory engineers decreed.

So for the last 18 months the old order has been giving way, rapidly, perceptibly, and not at all noiselessly, to the new. Floor after floor of the shops has been remodeled. Process after process has disappeared, to be supplanted by newer and better methods. Things have been swung into line. Time and space and manual labor have been economized. Power, automatically applied and easily controlled, has been caught up in a hundred varying devices—hydraulic jacks, monstrous elevators, pneumatic hammers, giant presses—to save human energy and to replace spasmodic effort.

In all, within 18 months the Packard factory has undergone an internal arrangement and improvement that has cost well up into the millions.

The whole huge factory of today is a group of inter-related systems, each doing its appointed work at a minimum expenditure of time and energy consistent with the highest quality, all of them converging on the particular system known as final assembly. The little systems, though indispensable quite, present too many details for even the honorable mention due them.

Four principal systems index the progressive manufacturing method and efficiency of the Packard plant. They are the motor assembly, the chassis erection, the enamelling perfection, and the stock conveying. Many of the items of each of them existed in the period before 1914, but the chain of manufacturing sequences which each of them now helps to form is distinctly of the new epoch.

Down one side of a long room come 50 glistening motors. They travel on an elevated track of cold-rolled steel. As each arrives at a given station it is surrounded by deft mechanics who fit to it flywheel, cam shaft, crank shaft, bearings, front end gears, carbureter, ignition timer, generator, electric starter, and all the pride and panoply of motordom. The work on each motor is done quickly, by expert fingers. The engine is moved along easily over the short stations by a light push of the hand. As it travels down the other side of the same long room, the motor acquires yet other parts.

From that point it is dropped into the block test room, to be "limbered up" or "worked in" under electric power. An overhead trolley transports it to the dynamometer department, where its own capacity is tested. Inspections have guarded it all along the line, and at the end there is a stethoscope test, in a sound-proof room, where one can imagine the apparently faultless motor awaiting as anxiously as a human patient the verdict of the listening doctor.

Meanwhile through a similar system, the permanent setting for the new motor has been taking shape. A chassis frame, bare, as barren as a Montana landscape, is placed on a chassis truck that is hooked to a chain conveyor.

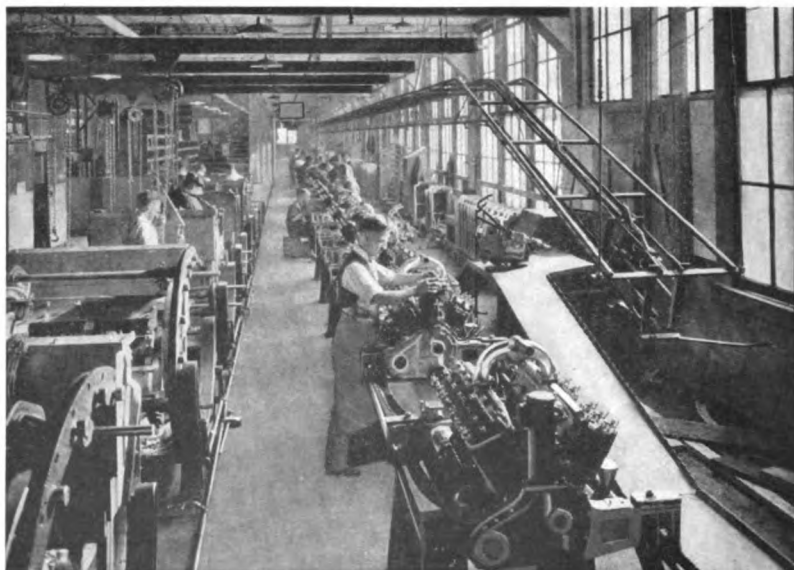

Motors moving from station to station as they take on form and power capacity

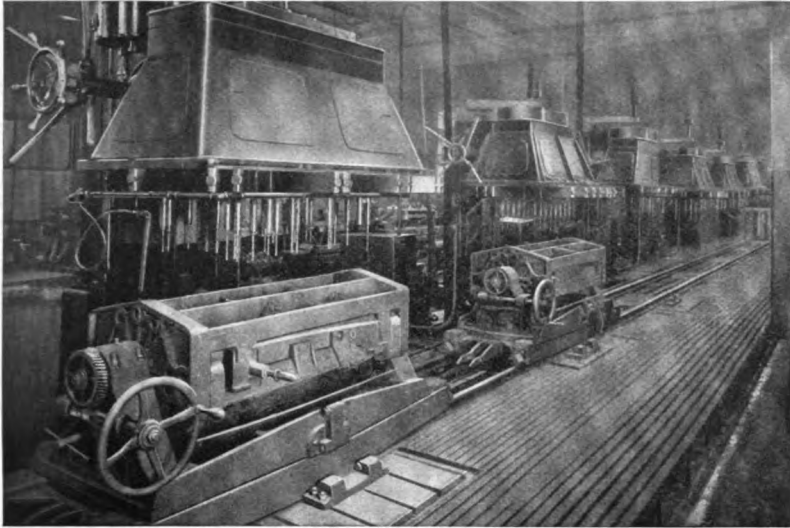

Line of eight multiple drills. As each crank case stops at a drill station the spindles bore a complete set of holes

It moves silently, regularly, at a certain, inexorable scheduled speed, along another long, long room. At each station en route, something comes out of a wall, or down through a hole in the roof, to join it. With an uncanny abruptness it sprouts running-board brackets, springs, muffler, front axle, even as Cadmus' armed men sprang from the field.

The old way was to push these frames along on a railroad of pipe construction. A gang of men surrounded each unit, and, stock not always being handy, frequently the constituents of the crew got into each other's way. In some places the work was done smartly; in others it lagged—and when one lagged it held all the others up. Now the assembly progresses uniformly and without a stop—carried along constantly by the conveyor chain between the concrete-embedded rails.

Air and naphtha, forced through a single hose, cleanse the chassis thus far assembled. The new way not only cleans more quickly, by many minutes, but it also scours more thoroughly than human hand has strength to rub. A similar spray coats the chassis with paint, applying it evenly, swiftly.

Then comes the first of a series of four great ovens, each 126 feet long, in which steam heat, intense and dry and even, bakes the new paint just sprayed on. While the drying process is going on, the chassis also is going on, and the chassis emerges from the oven just as the drying job is completed. Color varnish is applied by hand, and another oven yawns for the chassis. This one happens to be 13 degrees hotter than the first.

After a cooling period, the chassis is headed for the final assembly room. As it turns into that, it meets with parts coming from another of the major systems of the new Packard factory—the fenders and splashers and bonnet sides and tops, fresh and glistening from the scouring and enamelling they have received in a japanning plant that has no superior.

Where the enamelling rooms begin, the rough stock is welcomed with a mechanical cleansing process. Only a little time back, this stock was washed by hand, much less effectively than it is dealt with now. Nowadays a big

washing machine, through which 200 barrels of hot water circulate every minute, scours and rinses and almost sterilizes the stock. Then, just to make sure all roughness is taken off, a little hand work is added.

Thence the parts go to the vats, which have been filled with clarified enamel from the great 1,900-gallon clarifying tanks. Then in two more vast ovens—each of them cost \$20,000—the enamel is baked on by electric heat. The workmen who handle the materials in this room have washed air pumped to them; for all the windows are sealed and the doors kept closed. In one corner of the plant there are still to be seen a few of the small gas ovens that only yesterday were wonderful enough.

These enamelled parts, with many others, join the chassis as it progresses down the last 408-foot reach of the railroad. Paraleling the railroad in this stretch is a stock room 300 feet long. Inside the stock room bins are filled

at points opposite the stations on the railroad. A lot of stock for 50 cars is put into each bin at a time.

As the successive chassis come down the track, with here a worker riding on a bed slung beneath the frame, that he may attach the bottom parts as the car moves along, and there a worker hooking on a little platform for himself and a box to carry his stock, these bins are drawn on for the parts which the chassis must accumulate. At one point the body is let down from the floor above; the lights come on, the clock, the wheels, the tires.

The completed car, all decked out with varicolored tags signifying the approval of a legion of inspectors, reaches the last stop on the railroad. It has traveled a mile and a half, picking up equipment and finish and savoir faire. The completed car comes to a grade, the conveyor truck which has borne it all along now shoots from beneath it and goes shuttling back for a fresh frame, and the shining new twin six rolls easily down the ways and out onto the road.

Everything on it was brought into proper relation with everything else, carefully, along the line of least resistance, and—always—under the eyes of scrutinizing inspectors. Every part of it proceeded through its own orderly system of manufacture. Crank case and bevel gear, steering

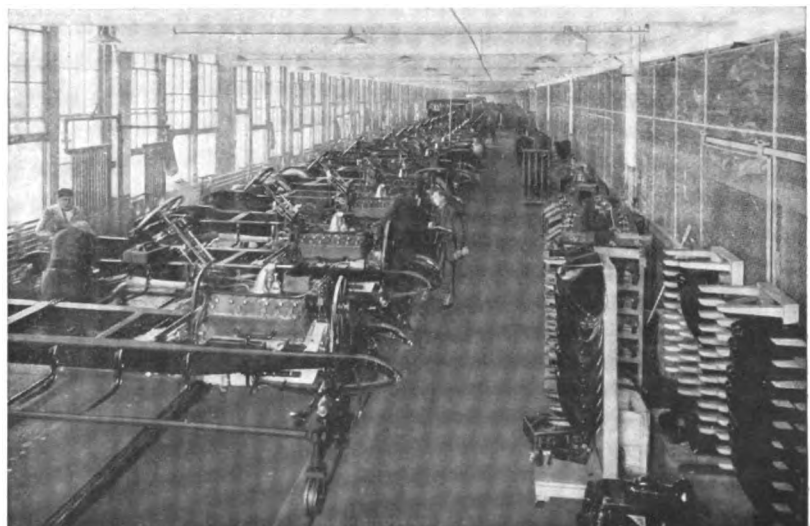

Some of the parts are attached by the workmen riding along with the car as it is being assembled

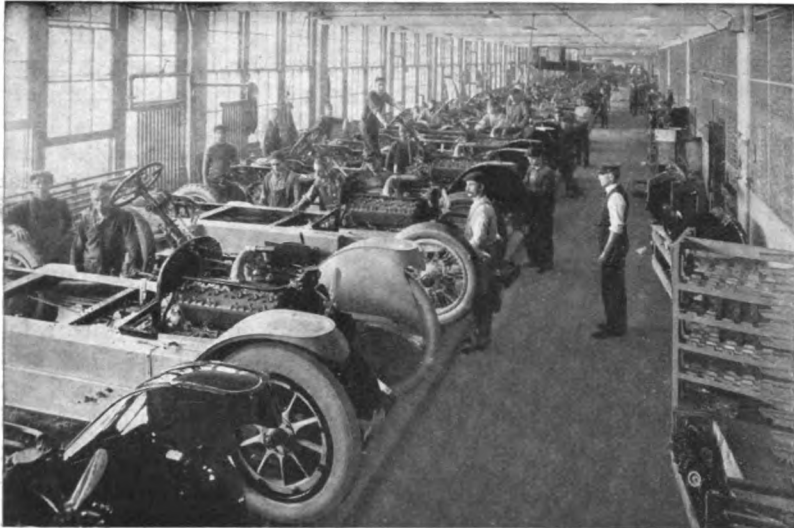

The final assembly. To the right is stock for 50 cars—fenders, splashers, radiators, lights, windshields, etc. Half way down line a body is being lowered from finished storage room

knuckle and transmission. each found its way along channels newly established, through processes nearly all arranged in their present order within the last two years.

The newest development, and the pride of the factory superintendent for the moment (it's altogether likely he has a new love by this time!) is the system for conveying the transmission and axle stock. The stock is stored on an upper floor. It comes down to the workroom by gravity feed, on an aerial railway, over which the boxes of stock ride to their stations like the cash carriers in a department store.

Heavy pieces, like rear axle cases, come down on an elevator which unloads automatically. It takes just a minute to distribute a piece of stock to any given point in the assembly room. Definite supplies enter at regular intervals, without the necessity of a call from the workman. Altogether, the foreman says, it's the finest stock distributing system in the land.

No sooner is a new arrangement established than the superintendent is agitating and hatching another set of plans for the tying up of more processes into a sequence.

Hand in hand with the physical realignment has come the development of the human organization within the factory walls. The constant effort is to provide a closer safeguarding of each process of manufacture, to the end that things will come through "all right." There is a highly compact organization of trouble hunters, for instance. Its single aim is to detect flaws where everything looks serene. One is a super-inspector of motors; another deals with layout and assembling problems; a third, with the mechanics of gears; a fourth, with miscellaneous mechanical troubles and tests; a fifth, with limits and disposal of obsolete stock; a sixth, with body manufacturing; a seventh, with the mechanics of the chassis, two with scrap in the truck and main divisions, and one with rear and front axles, transmissions and clutch assembly.

And still the human element remains the most baffling factor in the equation. Neither the obtaining of equipment nor the addition of necessary floor space, though each is a

tough problem, approaches in difficulty the communication to 12,000 men of the idea of efficiency and the working of them into a smooth practice of it. The measure of success achieved by the Packard in this regard is not exceeded in any other automobile factory.

Mitchell Wagon Salesmen in Second Annual Conference

Twenty salesmen and branch house managers of the Mitchell Wagon Co., representing many states, gathered at the plant at Racine, Wis., for the annual conference, on January 4.

A business session along with a discussion of the enormous business done the past year, and a glance forward toward the prospects that 1917 presents, featured the opening meeting. The men established a record that has never been equalled in the history of the company and are looking forward to a better year in 1917.

Luncheon at the Racine Hotel at noon was followed by an inspection of the plant and another conference, which took the greater part of the afternoon.

In the evening, the salesmen, along with the executives of the different departments, the office force and the officers of the company, enjoyed an informal dinner at the Elks' Club.

The second day's program included a conference, after which the men went down to Chicago. A theatre party and dinner at the Bismarck was the program after reaching that city.

Orders already on hand for 1917 will keep the factory going for practically six months, a condition that has never before been faced by this concern.

Electric Vehicle Association to Dissolve

The Electric Vehicle Association of America has made application to the Supreme Court for its voluntary dissolution because all the members, 1,141 of them, on April 14, 1916, joined the electric vehicle section of the National Electric Association. The association has no liabilities and assets of \$2,852.

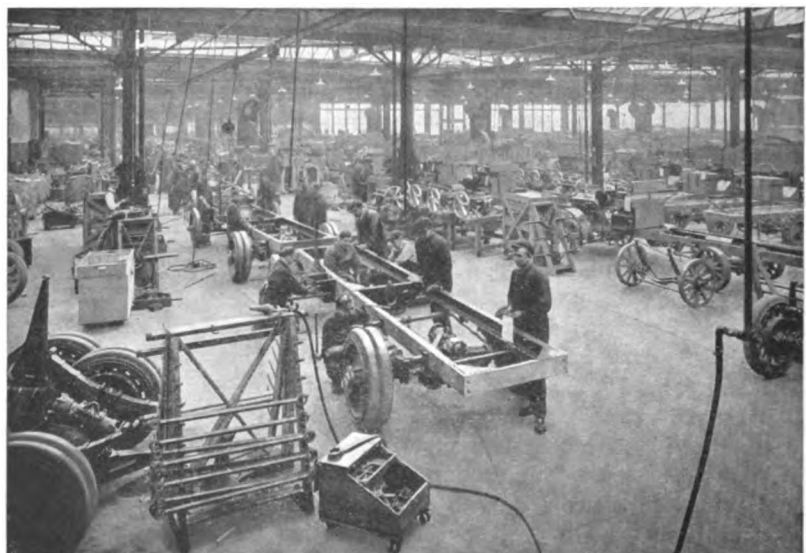

Trucks having built into them the endurance and stamina that sustain the burdens of the commercial world

Big Expansion in Use of Trucks

From July 1, 1914, to October 30, 1916, it is estimated the United States produced about 154,000 commercial vehicles valued at approximately \$308,000,000. In the same period the country exported 41,048, valued at \$112,289,564. From July 1, 1916, to October 30 last, only 5,787 trucks were exported, as against 7,908 exported in the same months last year.

According to H. W. Perry, secretary Commercial Vehicle Committee, National Automobile Chamber of Commerce, the manufacture of trucks and delivery cars has increased from an estimated production of 30,000 during the year 1914 to 72,000 in 1915, and 96,000 in 1916. Plans of the manufacturers for this year indicate a probable output of 125,000 vehicles.

Truck manufacturers have been working at the limit of their capacity for the last two years; additions have been built to old plants and new factories have been erected and others are in course of construction. Still the domestic demand exceeds the supply. So long as general prosperity and our industrial and commercial activities get no serious setback, the manufacture and sale of motor trucks will increase rapidly. Cost of manufacture has been cut materially in the last two years and truck prices have been lowered correspondingly.

Present tendencies among the manufacturers are toward building more intermediate sizes of trucks, particularly of 2½ and 3½ tons' capacity; toward higher prices for trucks of six tons' capacity and up, and of the intermediate and three ton sizes, and lower prices for the 1, 1½, 2, 4, and 5 ton models; toward a return to right-side steering and control and worm and internal gear drive. There is also some increase in the use of electric starters, governors, single rear tires, cast-steel radiators, and the provision of driver's cab as part of the chassis; also to square-spoke wheels.

There has been considerable speculation as to how the ending of the war in Europe will affect the American truck industry, but there does not appear to be any reason for pessimism. Visitors and inquiries from foreign countries seeking agencies for American cars and trucks indicate a conviction that there will be a big demand after peace is declared, and that European factories will be unable to meet it. Our trucks have gained a good introduction in foreign markets and have given such good service that they will be able to compete with European trucks. While many of the trucks now in army service probably will be returned to private use, the tremendous amount of reconstruction work to be done is expected to create an unusual demand for new machines. Should a period of general depression occur after the war in the belligerent countries and their colonies our own home market will absorb the total output, which is not now equal to the demand.

Traffic congestion on the railroads has extended the use and sale of trucks during the past year, and prospects are that it will require several years to build enough freight cars and locomotives to make up the present shortage.

It is impossible to forecast with any degree of accuracy the future developments of the motor truck. The manufacture of horse-drawn wagons provides some basis for estimating the motor truck absorption capacity of the country. In 1899, when the population of the United States was about 75,000,000, the number of business wagons

manufactured was 570,000; in 1904 it was 643,000, and in 1909, 587,000. With a population of more than 100,000,000 now, and the increased activities of the country, we should be building more than 750,000 wagons a year, except for the retarding influence of the motor truck. It is generally accepted that one motor truck does the work of three horse-drawn vehicles; therefore, there should be a potential market for 250,000 trucks a year, instead of 750,000 wagons, if they can take the place of wagons in all fields of work.

But it is fair to assume that wagons have an average life of ten years, and that on this basis there are in use today at least 5,000,000 wagons. No doubt the number is much larger, because there are 6,500,000 farms in the country and every farm needs one or more wagons. And this takes no account of the hundreds of thousands of wagons used in cities and towns. It will require 1,600,000 motor trucks and delivery wagons to replace the horse-drawn wagons now in use.

Motor truck manufacturers, who are producing less than 100,000 a year now, could double their output each successive year for five years before they could replace the wagons in use. The motor truck industry is in about the same position now that the passenger car business was in five years ago, and, while there are many doubters who think that the motor truck never will displace the horse in the rural districts, it is not to be forgotten that it was generally supposed five years ago or more that this same belief existed with regard to the passenger automobile, whereas the fact is that farmers are now the largest buyers of passenger cars.

The Right Bronze Means Economy

The Lumen Bearing Co., Buffalo, has issued a neat little booklet on bronze alloys which has been prepared for the purpose of affording its users a ready reference of their casting requirements. This company operates the largest jobbing brass foundry in America, under the supervision of a laboratory which has no equal in the commercial field. The booklet will be sent upon request.

Car Makers Classified on Basis of Number of Cylinders Used

Thirty-six new companies of more than local importance were added to the list of automobile manufacturers last year. Twenty selected the four-cylinder engine. Fifteen of these makes sell under \$1,000. Twelve chose the six-cylinder. Only one of these cars sells under \$1,000; ten sell for less than \$2,000. There are three new eights. Only one is priced under \$2,000. The following summary embraces 150 companies, and includes all makers of importance, and some of lesser note. In the totals the fours stand first, leading the sixes by 13.

Companies manufacturing fours exclusively.....	58
Companies manufacturing sixes exclusively.....	43
Companies manufacturing eights exclusively.....	12
Companies manufacturing twelves exclusively...	5
Companies manufacturing fours and sixes.....	16
Companies manufacturing fours and eights.....	6
Companies manufacturing sixes and eights.....	5
Companies manufacturing sixes and twelves.....	2
Companies manufacturing fours, sixes and eights	3

Wants Wider Roads to Protect Horses

The executive committee of the Carriage Builders' National Association at their meeting at Hotel La Salle, Chicago, November 11, passed the following resolutions:

Resolved, That it is the sense of this committee that we recommend that while the wide spread improvement and building of new roads is being carried on throughout the country, special provision be made to build all roads of sufficient width and character to give proper accommodations and protection to the use of horses.

Resolved, That this is necessary for the humane treatment of horses. Smooth, concrete roads as are now being constructed are of such a nature that the farmer cannot drive to market with the product of his farm with any safety to his horse.

Resolved, That special appeal be made to all associations and organizations interested in good roads to construct them in a way that will admit of the humane use of the horse.

Standard Parts Co. to Buy Western Spring

The Standard Parts Co., recently formed to take over the Standard Weding Co. and the Perfection Spring Co., is now arranging to take over the Western Spring & Axle Co. At a recent meeting of stockholders of the latter company a majority of 72 per cent of the stock voted in favor of the deal, while only 60 per cent of the stock is necessary for approval.

The properties of the Western Spring & Axle Co. consist of the Armstrong plant at Flint, Mich.; the Hess-Pontiac plant at Canton, O.; the Cleveland-Canton Spring Co., in the same city, and the Hess Spring & Axle Co., at Carthage, O.

Celfor and Buchanan Cos. Combined in Clark Mfg. Co.

The Celfor Tool Co. and the Buchanan Electric Steel Co., Buchanan, Mich., will be taken over by the Clark Mfg. Co., a new corporation organized for that purpose. The merger is solely for the purpose of strengthening both companies.

There will be no change in the manufacturing or selling methods of either company and the personnel of the organization will be the same. The new company will be capitalized at \$2,000,000 preferred and \$3,000,000 common.

Combining Pathfinder and Empire

A combination of the Pathfinder Co. and Empire Automobile Co., both of Indianapolis, in a new company to be known as the Federated Motors Co., with a capital of \$5,000,000, is being brought about by interests in the two companies working with New York banking connections.

Pathfinder men will predominate in the new company, which will have the same officers as the present Pathfinder Co., which is headed by W. C. Teasdale, while W. E. Stalnaker is vice-president and general manager.

Belgian Auto Engineers Visit Detroit

P. E. Kellecom and J. R. Perrier, engineers of the Fabrique National des Armes de Guerre, of Belgium, have been investigating the automobile production in Detroit. They state that the European countries plan to enter immediate quantity production at the end of the war.

Economy-Bellefontaine Merger

The merging of the Economy Motor Co., Tiffin, O., with the Bellefontaine Automobile Co., has been completed. The new concern will retain the name of the Economy Motor Co. and will move its factory from Tiffin to Bellefontaine, and manufacture passenger cars. Officers elected are: President, A. J. Miller; vice-president, R. W. Miller; treasurer, F. C. Spittle; secretary, Johnson West.

Another Air-cooled Car

The Holmes Automobile Mfg. Co. has been incorporated for \$250,000, at Canton, O., to manufacture an air-cooled automobile of original design. Arthur Holmes, vice-president and sales manager of the Franklin Automobile Co., Syracuse, N. Y., will be president and general manager. Associated with him will be C. H. Rockwell, assistant sales manager of the Franklin. A factory site has been selected in Canton.

F. S. Carr Sells Canadian Plant

The F. S. Carr Co., of Boston, maker of Neverleek top material has sold its Canadian plant at Granby, Que., to the Miner Rubber Co., of that place. With the increase in domestic demand for the company's products, it has been found practically impossible to continue affording proper attention to the Canadian end of the business.

Japanese Will Buy Trucks Here

G. Nakamura, son of a wealthy iron and steel manufacturer of Tokio, Japan, who is now in Pittsburgh, says he came to this country to buy motor trucks and was going to remain here until he acquired \$5,000,000 worth. These machines, he says, would be marketed in his own country, Australia and Russia, where there is a big demand for them.

France to Import Spring-making Methods

A well known consulting engineer has been engaged to reorganize the plant of one of the oldest and most famous axle and spring makers in France. This is to be done with a view to introducing multiple spring production methods, such as have been developed in this country, but which heretofore have been unknown elsewhere.

Allen Motor Co. to Build

The Allen Motor Co., Fostoria, O. will build a large motor car plant on a 50-acre site and will employ 1,000 men. All parts of the automobile will be made. The company announces that additional workers will be employed later because of other factories joining the Allen company.

Vance Fills Reynolds' Place

H. C. Vance has been appointed acting purchasing agent of the Studebaker Corporation to fill the place made vacant by the recent death of C. J. Reynolds. Mr. Vance has been connected with the Studebaker Corporation for many years.

Lytle Is Anderson's Production Manager

R. W. Lytle, formerly engineer and production manager of the Bimel Automobile Co., of Sidney, O., has accepted the position of production manager of the Anderson Motor Co., Rock Hill S. C.

Detachable Motor Truck Bodies Demonstrate Economy in Loading Time

Interchangeable Bodies and Trailers Solve Problems of Large Distributors, Effecting a Saving in Time and Freight Charges

Large retail concerns, and more particularly those which operate a system of chain stores, have found the transportation more or less of a heavy burden for the business to carry. Many such concerns were quick to see the advantages of motor truck delivery service and have thereby effected a large saving in practically every instance where intelligent effort has been expended to make such service properly efficient.

Some data has been gathered in connection with the business of the Liggett Company, which operates a chain of some 150 drug stores in the eastern states by the Motor Truck, and it shows how this firm has evolved an economical delivery system that is working to capacity at all times and which does not waste either time or effort in despatching each day's deliveries.

This company maintains a large warehouse at New York City, from which goods required by its various retail stores are shipped as needed. The orders for the stores in the Metropolitan district are delivered direct from the warehouse, and this includes some 40 odd stores in New York City, seven in Brooklyn, and one each in Newark, Paterson, Jersey City, N. J.; Yonkers, White Plains, Mt. Vernon, and New Rochelle, N. Y.

The warehouse has two internal loading platforms, or bays, both directly connecting with the shipping room. These are large enough for four horses or motor trucks to be backed to the doors of the shipping, and the floor is level with the average truck deck, so that loading may be done with hand trucks. The warehouse has large elevators, but the packages and boxes, unless of considerable size, are sent from the stock rooms on lowervators—broad skeleton shelves carried by endless chains on which the goods are sent down and automatically shunted into chutes that distribute them by gravity on the shipping room floor—this eliminating one handling and insuring against congestion or delay.

The stock for each shipment is collected as sent from the rooms above and piled on the floor. Because of the large number of items in the average order and the neces-

ity of packing them in the stock rooms, a good deal of time was lost, and the average time of loading a truck was from two to three hours. Possibly 2½ hours might represent a loading period. The idle time of the trucks was so large and the actual service or working time so much reduced that not only was the delivery distances shortened, but practically double the number of vehicles was required. With the operating expense of power trucks much greater than animal trucks, the need of keeping them moving was evident.

After investigation of the shipping room and vehicle equipment of several concerns a plan was decided. This in brief comprehended the use of five Packard trucks, three of which were immediately purchased. This gave the company one five-ton truck and four four-ton machines. For the five-ton and three four-ton chassis eight braced and reinforced, with crate sides and forward ends braced and reinforced, with crate sires and forward ends and removable skeleton tail gates for use if necessary. The sides and ends are high, so that bulky loads may be carried and covered with tarpaulins in the event of storm. Under the platform on either side at the front and rear of the body are two heavy steel brackets that are so located as to seat ahead of a frame cross member when the body is in place, and when the body is elevated four inches or thereabouts the chassis may be driven from under it.

The weight of the bodies is about the same as those that would be permanently installed on truck chassis of the same sizes, but the frame and platform is more substantial than if they were to be mounted on bolsters. In each of the loading bays a series of four overhead hoists were installed, these being standard equipment, each hoist consisting of shafts and gearing so interlocked that it may be operated by overrunning a chain, the power being so compounded that one man can raise or lower a body fully loaded. The hoist has four chains that are hooked into eyebolts at the corners of the platform. Each hoist is independent of the others.

The method of using these bodies is to have four suspended on the hoists at all times, and the loads are made up for these as rapidly as is possible, the time allowance for loading depending upon the work of the chassis. As the trucks reach the warehouse they are backed under the hoists in the loading bays and the empty bodies raised. They are then backed under loaded bodies, which

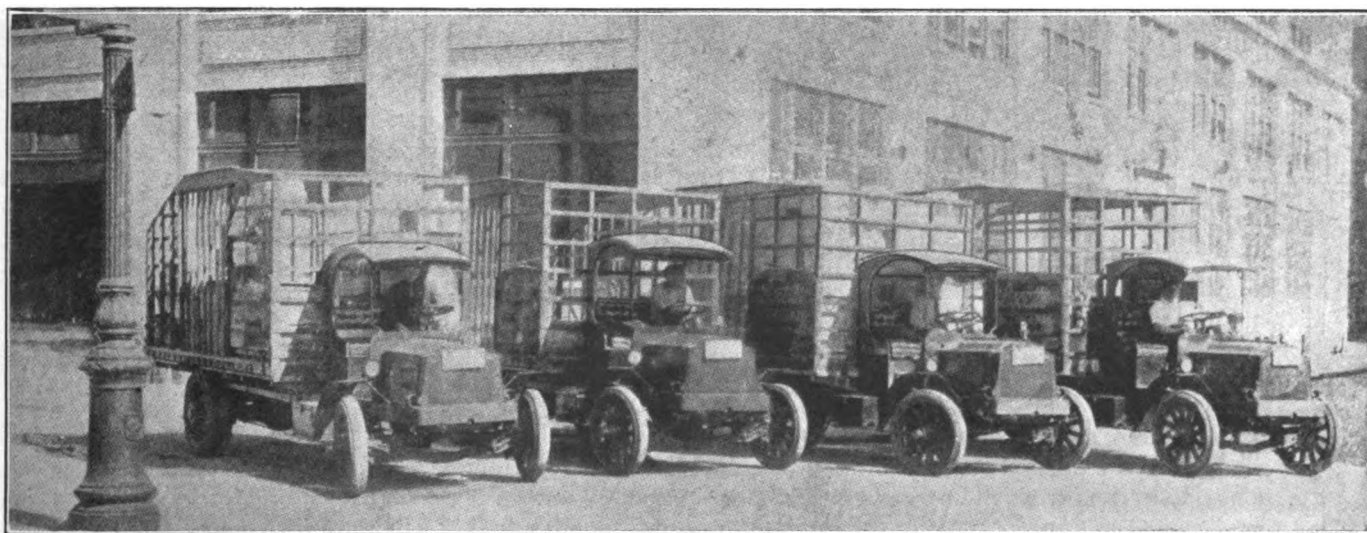

Fleet of Packard trucks used by Liggett Company to distribute stock from New York City warehouse to 58 stores, and to shipping terminals for 100 others, with the interchangeable body equipment

are lowered, and the machines can be sent away with an average of three minutes stop. Every afternoon the four bodies available are loaded and in the morning the trucks are driven to the warehouse at 8 o'clock. Three minutes later they are driven away loaded and four empty bodies are ready to be loaded.

Usually each truck can make several trips a day to the metropolitan district stores, and in addition there is regular haulage to be done daily to and from the freight houses and piers, for there are freight and express shipments to nearly 100 stores outside the district. Occasionally horses are used when extra transfer work is necessary, and sometimes horse trucks are hired for a day if there is unusually heavy delivery to be made, but ordinarily the four trucks are equal to the warehouse distribution requirements. Of course, the routes vary in length, but the work is equalized so that each truck handles about the same tonnage and the mileage is very close. The machines are driven an average of about 55 miles a day.

Long Distance Delivery by Trailer

The Liggett company operates five stores in Philadelphia and vicinity, one of which is at Germantown and another at East Liberty. The supplies for these are

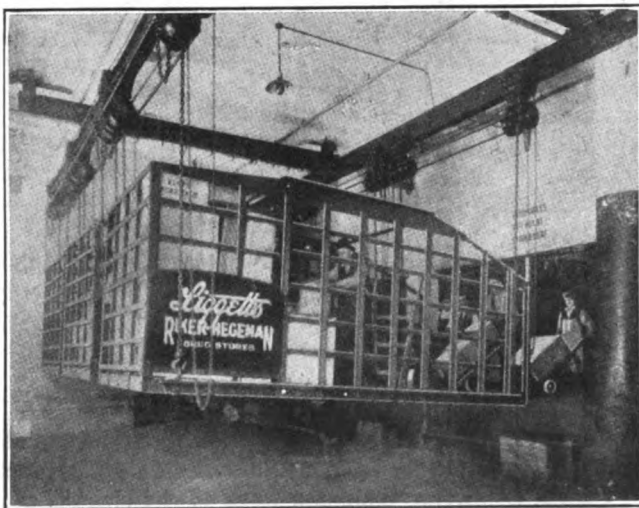

Loading three of the bodies in the loading bay at the Liggett warehouse, Twelfth street, New York City, while the trucks are making regular trips

shipped by freight and express on given days, the orders being received and handled as has been stated. With a view of determining the possibilities of economizing by sending the freight and express by truck over the road a series of experimental shipments were made. Three Troy trailers, each having capacity of five tons and equipped with tarpaulin covered tops, were purchased. The five-ton truck was selected for the work as it has the greatest load capacity. With the truck carrying five tons of freight and hauling a trailer with a similar load, the round trip of 225 miles between the warehouse and the Philadelphia stores has been made in two days, the outward run and the delivery being made in one day and the return trip in another.

The trip being straightaway and without stops, comparatively fast time can be made each way, and the crew does not work longer than when making regular routes from the warehouse. Besides saving three haulings, with lessened damage from breakage, practically two days' time are gained and there is an actual saving of from \$150 to \$200 a trip.

A similar experiment was made with the orders for the company's stores at Stamford and New Haven, Conn., which are respectively 37 and 77 miles distant from the warehouse. The round trip has a mileage of approximately 200. Leaving New York with a trailer and a ten-ton load the truck was driven first to Stamford, where the trailer was left at the store for unloading, the machine continuing on to New Haven, when its load was delivered. The delivery at New Haven was completed at 6:30 and then the truck returned to Stamford, where it and the trailer were garaged. The next morning the truck was driven back to New York, arriving there in season to do a half-day route. The net result was the saving of a day's time in delivery and rather more than \$100 and the stock was delivered in better condition than had it been sent by freight or express. The possibilities of this method of delivery are so large that it will no doubt eventually be adopted for the regular distribution.

Ice cream is served at all of the stores and the consumption varies with the seasons, but it is a stock that is in constant demand. The company has an ice cream manufactory from which the deliveries were first made by two two-horse trucks, the cream being packed in five-gallon containers that were in tubs filled with ice and salted to promote frigidity. The filled tubs and cans were delivered at the stores and empty tubs and cans returned to the factory. Because of the weight and shape of the tubs, but a few would be carried at a load. Loading and unloading was not a matter of great importance, but there were decided limitations to the work that could be done. In extremely warm weather, when the demand was greatest, the delivery was extremely urgent and the capacity of the animals was least without the use of additional vehicles.

One of the four-ton Packard trucks was equipped with a special body for ice cream delivery, this being constructed so that the load can be removed from the rear and sides. The bottom of the body and the sides were covered with sheet copper to a height of eight inches. Into this two tiers 130 cans of cream were packed, each can containing five gallons, and under, around and above them two tons of cracked ice. The loading could be done at the factory very quickly, as the cans and ice were always ready for packing, and in making the delivery the driver and helper had the cans and not the tubs, cans and ice to handle, so that time was saved at each stop. With this truck 1800 gallons of ice cream could be delivered to 30 stores when occasion demanded and by working overtime this could be considerably increased. The delivery was extended materially as compared with team haulage, and there was a decided saving when the company used its own product instead of that of an ice cream manufacturer, and in the event of emergency need not depend on other for its supply. The ice cream delivery worked out so successfully that the company's plan now is to establish a factory which will produce for all the stores, and the truck equipment will be increased so as to make a regular delivery to them. During the period of the year when the demand is smallest the trucks may be used for other purposes, or, if need be, laid up until they are needed.

Saving a Very Large Sum.

Because so much work is now done by trucks that was done by others for contract, or shipped by freight or express, and because of the fact that the company inaugurated its present service as early as possible after the merger, no very accurate measure of saving can be stated.

But representatives of the company maintain that the entire cost of the trucks, bodies and special equipment for operating them will be paid for by the lessened expense of distribution within a year, and that there is every reason to believe that with the expansion of the delivery zone to include Philadelphia, Stamford, New Haven and probably other cities that can be readily served by trucks, and supplying ice cream to approximately 60 stores from the company's plant, the economy will total many thousands of dollars annually.

There is, as will be noted, nothing radical in the uses made of motor trucks, but the conditions have been carefully studied and the facilities and methods adapted so that there would be no loss of time of the machines. The trucks are well cared for. The drivers are enthusiastic and interested men, who are well paid. Each man cares for his machine so far as is possible for him to do so, and every week he has a half day to work on it. The major repairs are made at the Packard service station. The trucks are kept in public garages, but the purpose is later on to establish a company garage which will have every facility for maintenance and repair. Besides the attention given by the drivers there are monthly inspections by Packard service men. Because of the attention the repair expense is minimized. The trucks are not overloaded, and excellent tire mileage is obtained. The results may be judged from the fact that when these data for this article were obtained the forward set of tires on the five-ton truck had been driven 21,000 miles, and appeared to be good for several thousand more.

To Produce Bodies on Progressive Production Method

"Just now in Detroit we are finishing one of the most important steps in the history of convertible bodies," says Walter L. Fry, president of the Springfield Body Co. "I am referring to the building of our new plant which is to be the largest and most modern convertible body factory in the world.

"For the first time in the history of the industry, we are going to build convertible automobile bodies on a new progressive production method which will rival the chassis quantity production system of the world's greatest motor car factory, in point of speed, efficiency and economy. From the time the raw timber, steel and other materials are unloaded from the freight cars until they appear in the finished product, Springfield bodies in our new factory will travel in a direct, straight line on one floor to their final completion. When completed, the new factory building will be 3,000 feet long and approximately 400 feet wide. A double side track extends the full length along one side with loading platforms the whole distance. Next comes a 30-foot crane way extending the full length of the building. Then come the assembling floors, 300 feet wide and running almost the entire length of the building.

"At the upper end of the factory building proper the lumber will be unloaded and stored. Small tramways will carry it into the kilns, where it will be thoroughly dried out. The tramways will then conduct the lumber into the main building and even here man labor is dispensed with in favor of automatic lifts which handle the lumber to the cutoff saws. From here it travels through the numerous wood working machines until all the parts are cut to the proper sizes and dimensions. At the point of the last

of these operations the wood parts enter the stock room which extends clear across the entire building.

"The wood parts are then drawn from the stock room and assembled in units. The units are gathered together and assembled in a large frame or cradle, called a buck. Each unit is placed in its proper location in the buck and securely clamped—the connecting members are then attached and screwed in place and the skeleton frame work of the body is revealed.

"The skeleton body is then removed from the buck, placed upon a low truck which travels on a track the full length of the building. The truck is fitted with an adjustable tilting turn table top which makes it instantly adaptable to any position desired by the workman. When the workman finishes his operation he throws a clinch and the truck is carried along by a moving cable to the next workman. Groups of workmen are stationed along the track, each group having its separate task. The materials which they use are automatically placed at their side by an overhead trolley system so that not a minute is lost. The most efficient work is produced at a maximum speed with a minimum cost.

"When the truck, with the body, reaches the end of the track, it is run on an electric truck which takes it direct to the freight car."

Herbert Chase Joins Office Staff of S. A. E.

Herbert Chase, who has been connected with the Automobile Club of America for several years as laboratory engineer and chief engineer, has joined the office staff of the Society of Automobile Engineers in the capacity of assistant secretary. Mr. Chase is treasurer of the society and a member of its council. He has taken a prominent part in the activities and conduct of the Metropolitan Section of the society since its organization. He has made numerous contributions of engineering value on tests and testing of motor car engines of the internal combustion type and on the possible uses of cycles other than that of the Otto engine. Mr. Chase's long service on the publication committee of the society will enable him to assume readily editorial work on the Bulletin and other publications of the S. A. E.

Mr. Chase's preparatory engineering education was had at Pratt Institute. He was graduated as a mechanical engineer at Sibley College, Cornell University, in 1908.

Inspection Minimizes Wastage

According to the experience of the Studebaker Corporation, Detroit, Mich., the biggest benefit derived from the thorough inspection systems employed in the huge plants is due to the fact that they save waste and so save money in manufacturing. The scrap-heaps of the earlier automobile manufacturers were full of parts more or less finished before the discovery of defects that led to their being discarded; there was little or no early inspection, and the work done on such parts was a dead—and serious—loss. In many cases parts were wholly finished before being scrapped.

Inspections actually begin at the sources of supply of raw material, and defects are unearthed even before material is shipped. Inspectors also go over raw material on arrival at the factories. Throughout manufacturing inspections are made following every process, and nothing escapes. Accuracy, integrity and economy are ensured by these methods.

Motor Truck Legislation in New Jersey and New York

There seems to be a movement on the part of the legislators to increase the tax and restrictions on commercial motor vehicles.

At the first hearing, at Albany, on November 21, at which Frank M. Baucus, president; Melvin T. Bender, general counsel, and Herbert W. Baker, secretary, of the New York State Automobile Association, were present, it was stated that the present \$5 tax was not based on anything definite, but was merely a means of helping an infant industry. Now that the industry has grown and as trucks are claimed to be very destructive to road surfaces, the taxes are to be increased.

Another meeting of the commission will be held in New York City. The matter has not yet been settled. The new schedule will be filed with the secretary of state and will go into effect February 1, 1917.

William L. Dill, Motor Vehicle Commissioner of New Jersey, with his committee of county highway engineers, held a hearing at Newark, N. J., on October 2 and a second hearing November 24, at which new regulations were proposed, together with a new set of registration fees. These will be considered by the next legislature and, if passed, will go into effect January 1, 1918.

Briefly, as will be shown by the following extracts, the new regulations will limit the speed, size and carrying capacity of trucks; will preclude the use of metal-rimmed wheels of any kind, will necessitate the use of sealed governors set for certain speed limits and will make compulsory the display of license plates, showing the maximum loads. Owners will be liable for all damage to bridges when carrying loads beyond bridge capacities; pneumatic-tired trucks will be licensed in accordance with pleasure car regulations and vehicles shall be restricted to one trailer, which shall be considered a four-wheeled vehicle and equipped with rubber tires. The fees proposed are to be based on gross weight, there being an annual fee and a special fee in September. These annual fees run from \$15, with a special fee of \$7.50 in September for a 4,000 lb. or less capacity truck to \$125, with a special fee of \$62.50 in September, for the largest vehicles of 27,000 lbs. capacity.

Extracts From Proposed New Jersey Laws

No commercial vehicle or truck shall be more than 96 in. width, outside measurements; in extreme cases the Commissioner of Motor Vehicles shall be privileged to issue permits for the operation of motor vehicles or trucks with a width of load over 96 in., where the weight of the load is not a factor.

That no commercial vehicle or truck shall be equipped with metal tires that may be in contact with the surface of the road, nor shall such vehicle or truck be equipped with any tires which have a partial contact with the surface of the road.

That the height of all commercial vehicles or trucks including load be limited to 12 ft. 2 in.

That all commercial vehicles or trucks shall be equipped with sealed governors or other automatic control, by which the speed shall be regulated, not to exceed the schedule attached hereto.

That the extreme length of motor vehicles or trucks shall not exceed 26 ft. 6 in.

That not more than one trailer or semi-trailer shall be

allowed to any commercial vehicle or truck; that in every case said trailer or semi-trailer shall be equipped with rubber tires.

An affidavit at time of registration shall be required from the licensee that the maximum weight in accordance with said plate shall not be exceeded.

That the commercial size of tires used on all commercial vehicles or trucks shall be determined on the maximum width of rubber and in no case shall the width of bearing surface unloaded be less than two-thirds of the commercial size.

That all license fees for four-wheeled trucks shall be based on the maximum wheel load carried on same.

All trailers are four wheel vehicles.

Tractors are motor power vehicles without bodies and shall be licensed on their gross operating weight at the prices fixed in the schedule for gross weight. Size of wheel and tire and rate of speed shall conform to articles 16, 17 and 18 of this report.

Semi-trailers are two-wheel vehicles without motor power and shall be licensed at their carrying capacity at the prices fixed for gross weight. Size of tire and wheel and rate of speed shall conform to articles 16, 17 and 18 of this report.

That trucks, tractors, trailers or semi-trailers equipped with tires smaller than required as per schedule, shall not be licensed.

Loads for rear wheels of motor or motor-drawn vehicles: That one-third of the gross weight of truck and carrying capacity combined must be within the limits of the schedule of the respective diameter of wheel, size of tire and speed in miles per hour, as shown in the schedule hereto attached.

Loads for front axles of motor or motor-drawn vehicles: That the front axle shall carry the balance of the gross weight of truck and load combined and must be within the limits of the schedule of the respective diameter of wheel, size of tire and speed in miles per hour for single tires, as shown by the schedule hereto attached.

All commercial vehicles or trucks equipped with pneumatic tires shall be licensed in accordance with the motor vehicle act governing pleasure vehicles.

Russell E. Gardner Retires from Chevrolet

Russell E. Gardner, president of the Chevrolet Motor Co., of St. Louis, a manufacturing branch of the larger Chevrolet company, retired from business the first of the year. He turned his large plant over to his sons, R. E. Gardner, Jr., and Fred Gardner.

Mr. Gardner, who is rated at several millions, moved to St. Louis from Tennessee 37 years ago without means. He began at the bottom in the buggy business and later acquired complete ownership of the Banner Buggy Co. and as the business began to fail he absorbed several other plants. It was this equipment that he made the basis of the organization of the Chevrolet Motor Co. of St. Louis.

A. A. G. O. to Meet February 1 and 2

Members of the American Association of Garage Owners are to meet in their annual convention during the Chicago show. The meeting will be held February 1 and 2, the Thursday and Friday of the show week, at the time when most of the visiting garagemen will be on the ground.

Metalwood Hydro-Mechanical Rim Shrinker

The Metalwood Mfg. Co., Leib and Wight streets, Detroit, Mich., is now manufacturing a hydro-mechanical rim shrinker or banding press for automobile wheel rims. This press is operated by hydraulic pressure. The motion is transmitted to the dies, which force the rim inward, by means of a powerful toggle mechanism. The front view, Fig. 1, shows the arrangement of the eight dies, and the side view, Fig. 2, illustrates the general construction of the press. The closing of the dies is regulated by the handwheel shown in the illustration, which, through worm gearing, controls the position of a nut and a screw bolt, which bears against the stop-plate or main casting of the frame. The variation of sizes is taken care of by adjusting this screw bolt forward, which increases the diameter of the ram. A receding movement of the screw bolt allows the cylinder ram a longer travel and a greater movement of the toggles which operate the dies.

Any lost motion in the toggles is compensated for by compression springs. The toggles are adjustable for angularity by means of outside adjusting screws, which may be seen in Fig. 2. All parts of the toggles are of carbon steel and the entire press is made of steel, no cast iron being used, except for the press legs. The ram is of hard semi-steel, finished and polished. The ram shoe or part carrying the pivots or connections to the toggles has babbitted bearings on the columns. The press has a hydraulic pull-back subjected to a constant pressure from an accumulator line. U-type chrome leather packing is used for the ram and also in the pull-back cylinder. The construction is such that the gland may readily be removed from the ram cylinder when new packing is to be inserted.

The machine is designed to operate under a hydraulic pressure varying from 1,000 to 2,000 pounds per square

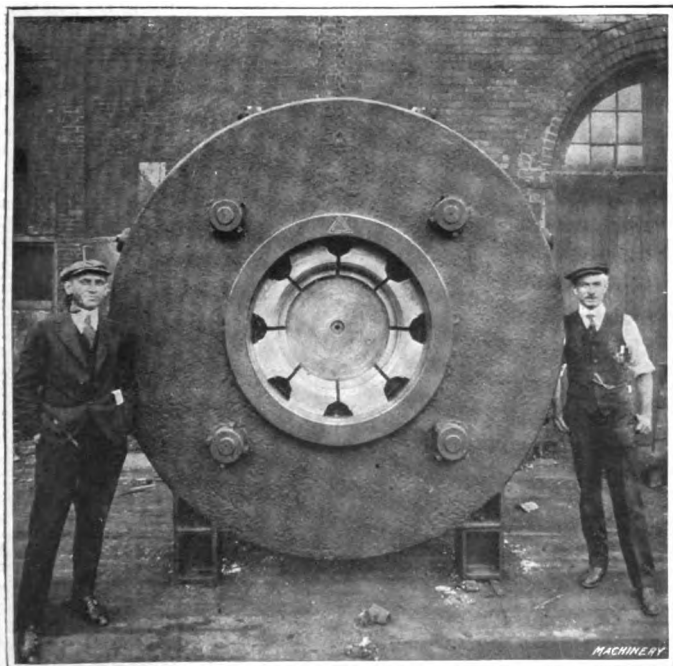

Fig. 1—Front view of Metalwood hydro-mechanical rim shrinker

inch, and at a pressure of 1,000 pounds it develops about 675 tons on the toggles or rims to be pressed. An increase of pressure causes the pressure on the toggles or dies used in forming the rims to increase at the same ratio. The dies are of carbon steel and are fitted with angular tongues and

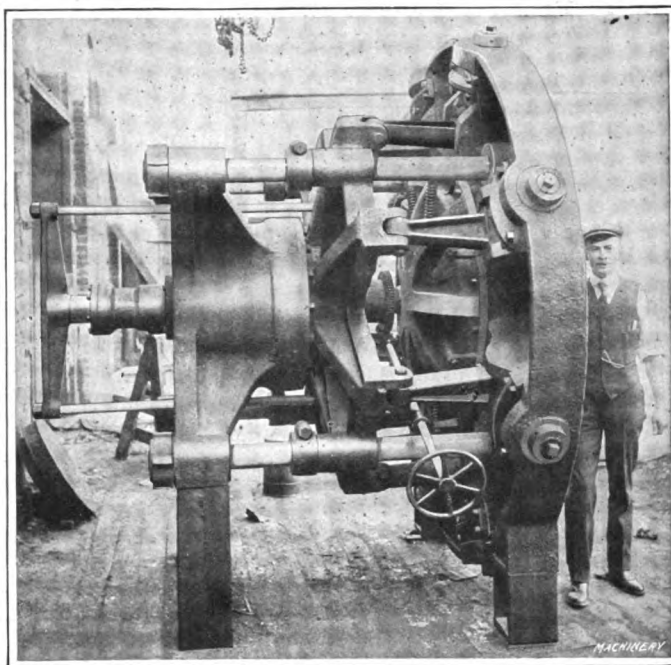

Fig. 2—Side view of rim shrinker

grooves, and held in place by screws in the die-block. The press has a maximum closure of 3 inches, and under test has made from eight to nine strokes per minute. The weight of the press is 26,000 pounds.—Machinery.

Carriage Makers' Club Anniversary

The Carriage Makers' Club of Cincinnati will celebrate its thirtieth anniversary on February 3, 1917. The club is one of the oldest organizations in the vehicle trade. It was organized March 12, 1886, but its actual life dates from February 3, of that year, when a meeting was held at the Grand Hotel for the purpose of getting leading members of the trade together. Those attending the meeting were D. M. Sechler, Grant H. Burrows, Alfred Hess, J. W. Breed, J. W. Fisher, Hiram W. Davis, N. D. Allen, Geo. Enger, Lowe Emerson, W. T. Haydock, H. H. Nelson, Henry A. Harris, Edward S. Ebbert, J. K. Reynolds, Louis Cook and W. A. Sayers. Many of these gentlemen are still living as leading figures in the vehicle trade. Appropriate proceedings will mark the anniversary meeting.

Temporary Receiver for Mayo Radiator

The Mayo Radiator Co., New Haven, Conn., will be conducted for one month by James E. Wheeler, appointed temporary receiver by the Superior Court. An effort to depose Virginus J. Mayo as president by action of the board of directors brought about the temporary receivership. James Duncan Livingston has been elected president by the directors and E. B. Shoemaker has been chosen vice-president and general manager. A hearing set for January 5 will determine if the receivership shall be made permanent.

Madison Buys Anderson Carriage Plant

The Madison Motors Corp., Anderson, Ind., has purchased the plant of the Anderson Carriage Co. The building has 100,000 sq. ft. of floor space and will be doubled in size.

Auto Body Architecture Hedged With Many Restrictions

"When a motor car is really beautiful, it never fails to receive immediate attention and cheerful praise," says Alexander Winton, president of the Winton Company. "It stands out from the great mass of cars as one of the elect. Everybody admires it. And yet the number of motor cars that satisfy the canons of artistic taste is small. Cars that win admiration for their charming forms and colors are few and rare. And this is so because the difficult art of creating them is but little practiced in America.

"The American custom of stupendous outputs resists the art. Where a manufacturer aims to make many cars, he finds that the creation of beautiful designs interferes with rapid manufacture. Only the maker whose output is relatively limited undertakes to satisfy artistic values, and unless he has the co-operation of buyers qualified to exercise critical judgment he soon tires of the effort. For after all it is the exceptional buyer who is promoting the art of creating cars that are delightful to the eye. Too many buyers take what they can get and let it go at that. The exceptional buyer specifies what he wants and will not accept less, and to his sense of beauty and his refusal to be satisfied with ordinary effects the manufacturer of artistic cars is chiefly indebted.

"Motor car beauty depends upon body designs and color harmonies, and it is neither easy to create beautiful body designs nor to give beauty of color to designs that lack harmonious proportions.

Many Restrictions

"Automobile body architecture is hedged about by many restrictions. Usually the body designer is not permitted to lay his own 'foundation,' but must take the chassis just as he finds it and then endeavor to lay what beauty he can on a foundation planned by somebody else, who may not have had the slightest conception of the meaning of beauty.

"Artistic bodies need to be in balanced proportion to the bonnet, but since the length of the bonnet is determined by the length of the motor and since the length of the body is determined by the wheel base, it will be seen that the body designer has not a great deal of latitude. Within a restricted area back of the motor the body designer must seat a fixed and arbitrary number of persons, and he must do his best to seat them comfortably. He must provide side doors for their entrance. Seats must be high enough, but not too high, and the height of the body must be kept in relation to the height of seats and of the bonnet. If, with all these restrictions, the body designer is able to weave into his design anything approaching harmonious relations and unity he has done a proud work. And yet he has not filled all requirements unless he has so laid out his creation that it will take color combinations most effectively. This element will not enter into his calculation if he is building a body to be finished in solid color, but solid color takes a car out of the class of beautiful creations, and hence where beauty is the object the color combination must be provided for.

"In earlier days the more curlicues, fretwork and what-not a body designer could find space for the more highly was his work regarded, but the progress is toward simplicity and the old-time designs are now regarded with amusement. Rapidity in manufacture also demands simplicity of design, but the simplicity that art requires is readily distinguished from the simplicity of barrenness. In the

latter case the artistic impulse of the designer is completely stifled.

"Considering all the handicaps under which the work of the body designer must be performed, it is not surprising that so few cars are genuinely artistic in appearance. Building on a foundation laid by mechanics, not artists, restricted to fixed and frequently cramped areas, forced to provide proper doors and seats and, when all this is done, permitted, if he can, to weave the structure into a beautiful unity, the designer who accomplishes all these results is distinctly an artist. And his work is entitled to all the enthusiastic commendation that it receives when it appears on the streets."

Winton Wins Axle Suit Appeal

The U. S. Circuit Court of Appeals at Cincinnati, O., has handed down an opinion reversing the decree against the Winton Motor Carriage Co. in the axle suit brought by the Lindsay Motor Parts Co.

The Lindsay company brought suit in the U. S. District Court, Cleveland, January 21, 1915, charging in infringement of driving axle patent No. 748,760. Judge John H. Clarke handed down an opinion in favor of the plaintiff on October 13, 1915, on the grounds that the inventor had shown evidence of the priority of his invention over similar axles, that the Lindsay axle constituted an invention, that the defendant was aware of the fact that the plaintiff had obtained patents on the invention, and other particulars.

The feature of the construction covered by the patent was that it allowed the inner or driving axles to be longitudinally removed from the tubular sections and inspected, repaired or replaced without disturbing the body of the car or dismantling the outer casings. The construction also permitted the differential to be inspected or withdrawn without dismantling any part of the car other than one-half the central section of the axle.

Judge Clark handed down a decree on November 20 calling for a perpetual injunction against the Winton company restraining it from making the type of axle in question. The company appealed December 8, 1915, and obtained on the same date an order from Judge Clarke suspending the injunction during the appeal of the suit.

Sheldon Gets Kardo License

The Sheldon Axle & Spring Co., Wilkes-Barre, Pa., has taken a license under the Kardo axle patents. These are the patents on which litigation has been pending for some time, and on at least one of which a decision is expected early this year. Both front and rear axle design is covered by the patents, and the Sheldon company now is able to furnish those car makers desiring to use this particular type of axle with members that are licensed under the patents.

Axle Has Ratchet Compensating Device

Manufacture of a new axle embodying a ratchet compensating device instead of the usual differential is planned by the A. C. Axle Mfg. Co., just formed with \$1,000,000 capital stock in Philadelphia, Pa. J. D. Allen, the inventor of the axle, is president of the company; A. P. Fisk is vice-president; A. C. Bunnell is secretary, and H. W. Savage, treasurer. The design of the device is said to be such that a positive drive is given to both wheels.

Paint Shop

Vigilance in Varnishing

The practice of thinning rubbing varnish has been condemned and justified in terms most emphatic, according to the viewpoint of the parties engaged in the controversy; but as a general proposition we think it has a greater weight of evidence against it than can be summoned to its aid, writes M. C. Hillick in the *Painters Magazine*.

Special emergencies, or emergencies of the common sort, may dictate the policy of thinning the varnish in question, but, apart from these events, the practice should have no standing in the court of paint craftsmanship.

The rubbing varnish, as it comes from the manufacturer, has a combination of elements which the maker of it has established at great expense, and, when the painter undertakes to change the nature of the composition united in this very sensitive and complex material called varnish, he is making a venture similar to sailing the uncharted sea, with the same promise of disaster confronting him.

It is, of course, understood that in the every-day circumstances of the shop, conditions will arise which seem to invite, and sometimes compel, an experiment not sanctioned by theory or approved practice, but all such occasions are the exception and not the rule. Only in extreme cases, and when all other plans fail to offer relief, would we assume the risk of thinning rubbing varnish, or, for the matter of that, any other kind or sort of varnish.

The writer does not say that it cannot be done, and done successfully, but he discourages the practice as a practice, for the sufficient reason that, while one is busy making the venture a success, a hundred other painstaking men are lamenting a dire failure of their efforts to improve on the product of the varnish maker.

The right and logical method of using a varnish, rubbing or finishing, is to follow the directions of the maker of the material. This practice is being followed more closely today than in times past, and it may be accepted as the one outstanding reason why varnish-room failures have been reduced to the minimum, and why varnish makers are declaring that their "trouble men" are finding themselves, like Othello, without an occupation.

Just at this time it may chance that the painter is considering the advisability of getting his winter supply of varnish in ahead of the cold weather. This is always, in the northern section of the country at least, a wise provision.

The season of frost and freezing is a bad time to have varnish in transit. Varnish is about the easiest thing in the world to get chilled past the workable state; and a night or two of extreme weather, with the zero mark flirting with the forecaster, is all sufficient to give the varnish a stubborn disposition and wreck the hopes of the finisher.

Better then get the winter supply of varnish in early; or, at any rate, ahead of the real winter weather.

In the event of getting caught, as in the best regulated shops it sometimes happens, with a supply of chilled varnish, the reasonable way out of the difficulty is to place the lot in a situation affected by a gradually ascending

thermometer, and thus, by easy stages, heat the varnish up to a normal degree, and eventually past that mark. Then continue to store the supply in warm quarters, and by delaying the employment of the material for some little time it will be found, as a rule, that it will work and shine forth with its perfectly normal character.

Varnish has a very human side to it, and only when this characteristic is respected, and in a measure catered to, may we expect to make it serve every purpose for which it is intended. The surface colder than itself need not be expected to receive it in the right manner. Antagonism between it and the varnish is a natural result, concerning the outcome of which only a bad surface disorder need be predicted.

Before using the contents of the varnish container it is well to always open the latter a half-hour prior to varnishing. This allows for the escape of the gases confined in the closed vessel, and insures a smoother and finer working material.

The temperature of the room in which the varnishing is to be performed needs also to be taken into account. As nearly as possible, this room heat should correspond to the warmth of the varnish, and to the condition of the surface. Indeed the three chief factors involved in the process of varnishing must correspond very closely in point of temperature, and all should have a warmth approximating 75 deg. F. Along with these should come apartment conditions of a most satisfying sort—ventilation, light, cleanliness, uniform conditions, etc.

It is directly in line with safety first to strain all varnish before using. Even the finest finishing varnish may have some minor sediment lurking in its depths, which only a strainer will be able to catch prior to its appearance above the surface. This is a practice which the best finishers never fail to observe.

Varnish should be worked only to the extent of getting it in a correct position on the surface. All varnish, rubbing and finishing, thrives best when disturbed the least. In other terms, after flowing it to its appointed place on the surface, cross-brushing it just enough to ensure uniformity of flowing to a certain depth of film, and catching up the edges, it may well be left severely alone. If it is of the right sort it will then take care of itself, and form to a body deep and rich and beautiful in proportion to its quality and royal substance.

The varnish "tease"—the man who persists in working the very life out of the varnish through excessive use of the brush—is an expensive luxury around the varnish-room. Better transfer his services to some other department of the shop, where his opportunity for doing damage is less pronounced.

Again, varnish ought never to be turned out into service before it is fully fit—free from dust and hard enough to be unaffected by mud, dirt, and other active road or garage accumulations. Varnish, while really one of the finest protective mediums, and one of the hardest substances, after a certain period of maturing upon the sur-

face, known to the craft, is prior to its arrival at this stage an exceedingly sensitive material, and quite likely, when encouraged, to perform some amazing changes.

Finishing varnish depends for its capacity for wear, and for enduring abuse and hard knocks, to no small extent upon the resources and stability of the rubbing varnish coats. These coats, then, may well be made the very bone and sinew of the entire varnish fabric—the chief cornerstone, if you will, of the finish.

They need to have, first of all, a quality beyond reproach; second, they need to go to the surface in a full rich body; in point of fact, they must be so-called flowing coats, capable of drowning out all the minor atoms of fine dust and wisps of floating matter.

They also need body and substance for rubbing uniformly throughout. And, as has been explained in these columns before, they should be allowed to carry as much of their original depth as may be possible, consistent with the required measure of reduction through the process of rubbing.

In making choice of a varnish, consideration should be given to the class of varnish likely to be best suited to the special requirements of the work. The car or carriage, for example, that is to go into service at a minimum period of time following the application of the finishing varnish, may well carry a varnish suited, in the matter of drying qualities and general adaptability, to the special needs of the individual vehicle. Indeed, this phase of the matter should be given strict attention, and choice of the varnish made accordingly.

A highly elastic varnish for work that, in the nature of the case, must be handled quickly, would be quite as much out of place as would be a varnish of the fastest possible drying capacity upon the car given a leisurely schedule of progress through the paint shop.

It therefore becomes a matter of serious importance when the question of choosing the class of varnish best suited to the needs of the work comes up for disposition. It is right at this point, in many cases, where the reputation of the painter is made or unmade, or becomes a negligible factor.

It often happens that a good job of finishing is ruined through attempting to remedy a surface defect after the varnish coats have been developed in fine order upon the car or carriage. This cannot be performed successfully once out of a hundred times of trying. The place to perfect all surface deficiencies is under the color coats; and at least under the varnish coats. Such work at once becomes an expensive experiment; never an assured process of skill.

Another feature of the surface-building problem intimately related to the development of the varnish coats is that of making the under coats, including the color coats, conform, in the measure of elasticity, as near as possible to that of the varnish coats, and especially to the finishing coat. A direct line of harmony should exist between the supporting foundation and the protecting varnish.

In the effort now being made to give the work of painting the vehicle equipment greater durability, and, if anything, more brilliancy, this study of creating a closer relationship between the under and the outer coats of the finished fabric—giving, in a word, a more complete chemical working base to all the complex machinery of the various things combined in what is understood as the finish—grows into robust importance. The question of a more

uniform elastic state of the mediums employed, in the light of recent data, becomes an immediately essential one.

The practice of mixing two or more grades of varnish of the same make, or two or more varnishes of different makes, in order to obtain a certain character or temperament specifically suited to meet the requirements of one's trade, is more or less adhered to, even in this day of improved varnish-making results. It is a practice, however, that has little to justify the painter in taking the chance of having the work come out looking decent under the glow of the "hodge-podge" concoction.

No two varnishes, or no two grades of the same make of varnish, have precisely the same disposition, or the same chemical composition, or the same tendencies to do the same thing; and, for this reason, apart from numerous others, the custom of mixing varnishes is lacking in the essential element of certainty to recommend it. In this case it is a wise plan to let your varnish maker serve your various needs with a varnish fitted to them.

Advice may be consistently tendered the car or carriage user relative to the periodical revarnishing of the vehicle. Excessive wear of the varnish is more costly, ultimately, than frequent varnishing which obviates the strain on the varnish fabric due to a lack of renewal of the finishing coat at the time it is most in need of additional protection. At a nominal expense the surface may be kept well nourished with an ample body of varnish, the simple requirement being a fresh coat, applied whenever the face of the finish shows a decline from its maturity. Let the vehicle owner know concerning this matter, and, in a great majority of cases, he will prove quite willing to co-operate with you in getting another coat of varnish in place upon the surface. Both the vehicle owner and the painter may thereby profit through this campaign of co-operative vigilance.

The varnish foundation worn threadbare before it is given additional treatment can never be fully restored to its former vigor. The best that can be done for it is to patch it up and give it an artificial stimulant, and reinforce its shattered arteries, and impart to its sinews some of the old life.

Then, too, it is well that the vehicle owner should know something of the necessity of giving the highly-varnished surface storage quarters amply lighted, for light is the life of varnish, and at the same time it prevents the varnish from turning green or otherwise discoloring—preserves, in short, its original brilliancy, tone and quality. And with light should come the storage quarters devoid of moisture, save the normal amount, for anything above this is certain to work injury to the luster and durability of the varnish.

Repainting That Automobile in a Small Shop

In repainting the automobile nowadays it is just the same as with buggies and carriages of old—prices are cut all to pieces so it is a tough proposition for the painter in a small shop with little room. If you are in the business you have to do the best you can. In a small shop just aim to do one a week.

Set the car up in a good light place so you can see good all around it. Take the wheels off, if you can. Clean off with gasoline and let stand a while to dry out, if you have the time. If not sand-paper good all over with 1½ sand paper, and give it a good dusting. Then give a coat of lamp black all over. When it is dry give it another coat

of drop black, then color and varnish. When dry, moss off and finish. The best thing to do before you give the body and chassis a coat of lamp black is to give it all a coat of rough stuff, mixed half lead and half filler. Put in a little oil and japan and thin with turpentine, then coat all over. This kills the dirt and dries hard as a bone over night.

For that cheap job of repainting, just sandpaper the coat of rough stuff, dust good and give a coat of strong color varnish, such as you can buy most any place. After your strong color varnish is dry, moss and finish—no stripes—everything black, you know.

This is for the small shop to compete with that city man who advertises to paint runabouts at \$12 and two-seated automobiles at \$15 to \$20.

A finishing varnish: Use a one-coat coach varnish for body and chassis and let it stand over night and it is ready to go. Try this and see if I am not right. It's the quickest and only way to meet this kind of competition.

W. A. Riggleman.

Kelly-Springfield Wins More Damages

Final settlement has been made of the long drawn out litigation over the Grant patent between the Kelly-Springfield Tire Co., New York City, and the B. F. Goodrich Co. and Republic Rubber Co. Judge Sanborn, in the United States District Court in Chicago, has accepted the report of the master appointed to assess damages, awarding damages of \$262,000 against the Goodrich company and \$114,000 against the Republic company.

The Grant patent covers vehicle tires of solid rubber with internal wires, such as now are used almost exclusively on horse-drawn vehicles, and the master assessed his damages on a basis of 5 cents per pound of infringing tires sold.

During the past year the Kelly-Springfield company collected \$219,000 from the Diamond Rubber Co., a subsidiary of the Goodrich company, for infringement of the patent, and has pending other litigation of a similar nature against other tire companies. While the damages may seem large, it is pointed out that the vehicle tire business is a large one, and that the 5-cent-a-pound basis was set as the "reasonable royalty" that legal precedent and firmly established rules call for.

Litigation over the Grant patent has been in the courts since 1897, and in 1899 the Consolidated Rubber Tire Co. was organized to take over the Rubber Tire Wheel Co., then owner of the patent. On January 1, 1914, the Consolidated company was in turn taken by the present company, the Kelly-Springfield Tire Co., which, in addition to making a big place for itself in the tire industry through the quality and quantity of its tires, has pursued the Grant patent suits with vigor, through long and bitter contests, realizing the patent as one of its important assets.

October Truck Exports Smaller—Passenger Cars Gain

Increased exports of passenger cars and parts, with a diminution of exports in commercial cars, was the feature of the export trade in October. Figures given out by the Department of Commerce show that during October there were 1,144 commercial cars, valued at \$3,635,291, and 4,880 passenger cars, valued at \$3,756,768, together with parts to the value of \$1,949,060, exported to various foreign countries. For the corresponding month of last year the

figures were: Commercial cars, 1,596, valued at \$4,307,190; passenger cars, 3,479, valued at \$2,749,255; parts, not including engines and tires, \$1,819,950.

During the ten months of 1916 the figures show that 15,917 commercial cars, valued at \$44,006,346, and 51,699 passenger cars, valued at \$36,049,497, together with parts, not including engines and tires, to the value of \$20,091,793, were shipped abroad. During the same period of last year the commercial car exports numbered 18,865 machines, valued at \$52,076,406, and passenger cars to the number of 34,515, valued at \$29,543,227. The exports of parts, not including engines and tires, were valued at \$12,814,809.

France bought 522 cars in October, valued at \$1,782,088; United Kingdom, 684 cars, \$1,687,152; Canada, 1,021 cars, \$718,962; West Indies and Bermuda 665 cars, \$505,198.

General Motors Subsidiaries Reincorporate

Subsidiaries of the General Motors Co. operating the Michigan plants in Flint, Lansing, Pontiac, Saginaw and Detroit have reincorporated and had their capital stock reduced to \$10,000 each, the companies concerned being the Buick Motor Co. and Weston Mott Co., Flint; Jackson-Church-Wilcox Co., Saginaw; Oakland Motor Car Co., General Motors Truck Co., Pontiac; Northway Motor & Mfg. Co., Detroit; Olds Motor Works, Lansing. The new companies of names similar to the old, are selling organizations only, their plants and other assets being owned by the General Motors Co. By this move the General Motors Co. becomes legal possessor of the assets of the subsidiaries which it formerly owned through the medium of stock ownership. W. C. Durant, T. S. Merrill and H. H. Rice are the incorporators.

Only One Trailer Proposed in Cleveland

The proposed new traffic law now before the City Council of Cleveland, O., prohibits the use of more than one trailer in that city; in addition, when a trailer attached to a truck is loaded with more than 500 pounds an extra man must accompany the driver. In ascending a hill of more than five per cent grade the measure requires that the second man must be on the trailer. Trailers must be equipped with suitable brakes and safety chains. Probably the most objectionable feature to the truckmen is the one which bars from the streets any trailer with steel tires that with its load has a weight in excess of 750 pounds per inch of tire.

Big Buggy Business

The Hercules Buggy Co., Evansville, Ind., has just finished two large additions to its factory at a cost of \$100,000, for the purpose of giving their customers prompt service at all times. During the past year the company was compelled to withdraw salesmen from the field for about 60 days because it had more orders than could be shipped promptly. The company manufactured and shipped 89,247 Hercules vehicles during the past year, making a record of over 390,000 vehicles in the past five years.

Ford Workers Double in Number

There now are 55,372 employes of the Ford Motor Co. in the United States, of whom 42,340 work in the home plant of the company in Detroit. A year ago the total was 23,342.

Eliminating the Gudgeon Pin

The evolution of the gasoline engine has long since passed into a mere matter of improvement in detail. Viewed in this light, the basic idea of the designs of pistons described in *Light Car*, an English publication, is of greater importance than would appear at first sight:

As a rule, neither the small end bearing of the connecting rod nor the gudgeon pin or piston bosses are nowadays apt to give trouble or wear unduly. There are, however, certain disadvantages in the usual piston and connecting rod assembly which the inventor of the pistons shown in the accompanying sketches claims to have overcome, at least to a certain degree. But before we do more than allude to this fact, the construction of the piston assemblies must be described.

The fundamental idea, embodied in each of the alternative designs shown, is to employ the head of the connecting rod itself as the actual receiver of the pressure of the expanding charge. To this end the connecting rod terminates in a hollow spherical head, of such size as

method has to be adopted to permit the assembly, or separation of the head and sleeve. In C, D, and E the lower retainer or seating is separate from the piston, and is inserted after the spherical head is in place. A split ring in a groove on the outer face of the retainer springs outward into an annular recess in the sleeve, and so locks the whole. The retainer may be in two parts when the big end of the connecting rod is too large for a single ring to be slipped over it, but the spring ring is, of course, in one piece.

In the design D a strengthening web in the interior of the head is shown while an alternative form of top suitable for two strokes is also indicated.

A very large bearing surface is provided in design E. The upper retainer is almost hemispherical, and comprises a thin sheet pressing, much perforated to enable the explosion pressure to act directly on the head. The lower retainer is also a part spherical pressing, held in place by a split ring, as already mentioned.

In F the sleeve is in two parts, held together by a channel section ring, as shown; the ring in question also, if desired, acting as a piston ring.

In G the sleeve becomes almost a normal piston, except for the method of attachment to the connecting rod, which is by a washer and nut. The under surface of the washer is ground to the same radius as the upper surface of the piston, and both washer and piston top are perforated. As the connecting rod oscillates, the washer, of course, rides over the face of the piston.

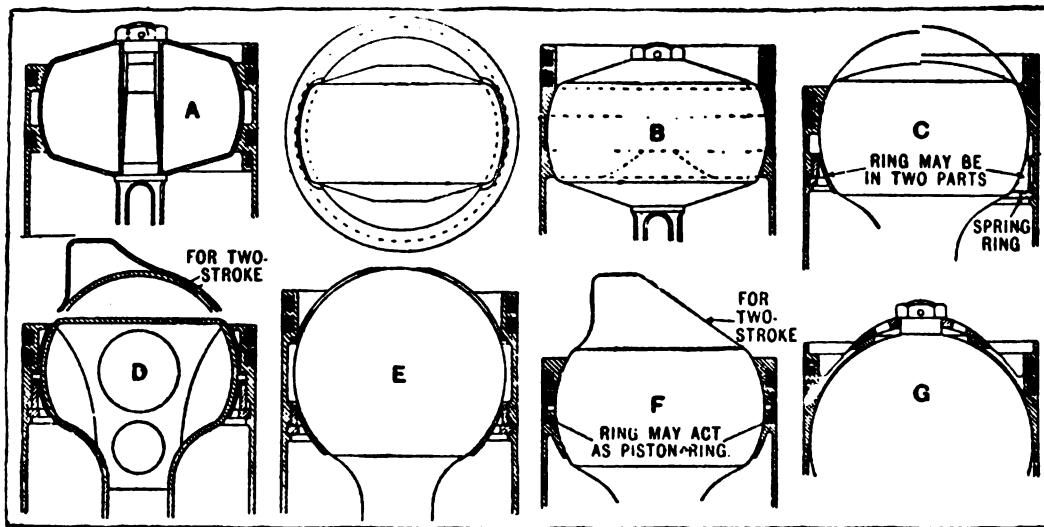

Alternative designs in piston and connecting rod assemblies which dispense with the gudgeon pin and allow the explosion pressure to be exerted directly on the connecting rod

almost to fill the cylinder in which it is to operate. Just sufficient clearance is allowed to permit of a cylindrical sleeve being interposed. The sleeve, it will be seen, is fitted with compression rings to prevent loss of gas over its outer face, but the closeness of fit and the film of oil are relied on to retain compression between the head and the sleeve.

In the design A, shown in section the hollow head is separate from the connecting rod, an extension of the latter passing through a central hole in the former, the two being held together by a nut. B is similar in design, except for the location of the piston rings, and the greater wearing surface this difference allows.

Between A and B is a figure explaining how the sleeve is removed from or replaced on the head. The nut holding the head to the connecting rod has been removed and the sleeve and head withdrawn bodily. By then tilting the sleeve about the head till it is horizontal instead of vertical, two cut-away portions in the lower part of the spherically shaped retainer allow the sleeve to be drawn off endways; that is, in the direction of the observer's eye, as looked at in the figure.

In the other designs indicated the hollow head forms an integral part of the connecting rod, so that some other

Among the advantages claimed, some of which are obviously justified, are: (1) Elimination of the gudgeon pin. (2) Increased size of "small end" bearings. (3) Universal action of the joint, eliminating the ill effects of slight errors in machining the ordinary design. (4) The extent of oil film tends to prevent "knocking." (5) Oil in the crankcase is kept away from the main source of heat—the top and under side of ordinary type pistons—thereby preventing oil wastage and carbonization. (6) Considerable saving in weight.

In connection with the last claim, the designer, T. J. Biggs, states he can build the two elements of steel to be of less weight than are the aluminum piston and steel connecting rod of the usual design. And there is no reason, he says further, why the sleeve and spherical head should not be of aluminum, and, therefore, lighter still.

Kelly-Springfield Plant

Plans for the new plant of the Kelly-Springfield Tire Co., of Cumberland, Md., are being prepared and the builders expect to break ground early in the spring. When housed in the new factory the productive capacity of the Kelly-Springfield Company will be increased 400 per cent

Dodge Method of Testing Brass and Bronze

An ingenious method of testing brass and bronze is employed by Dodge Bros., Detroit, for the purpose of deter-

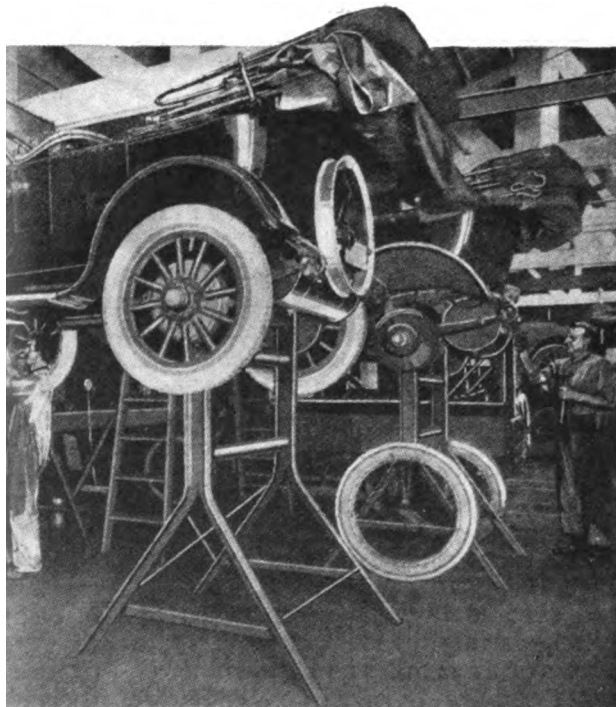

repair pits, but hoists its cars onto service stands, giving the
ty of room and light in which to work

ing the proportionate copper and lead constituents. The process is somewhat similar to electroplating. The metal to be tested is dissolved in acid and in the solution platinum gauze electrodes are placed. Direct current is applied and the resultant electrolytic action causes the copper to be deposited on one electrode and the lead on the other. Delicate scales give the weights of the coated electrodes, and the rest is easy. Platinum is used because it is unaffected by the acids used. Incidentally, platinum is from \$98 to \$112 an ounce in these war times.

Le Roi Company Takes Over Milwaukee Machine Tool

The Le Roi Co., Milwaukee, Wis., capital \$350,000, has taken over the plant and the gasoline engine business established several years ago by the Milwaukee Machine Tool Co., and will manufacture four and six-cylinder engines for passenger cars, light commercial cars and light trucks. Chas. W. Pendock is president and general manager.

The plant is located in West Allis, suburb of Milwaukee. The machine tool business has been removed and consolidated with the Kearney & Trecker Co., large builder of milling machines, also located in West Allis.

Japan Inspecting Exports

The Japanese government has instituted a system of inspection of all exports so that Japanese goods will not disappoint foreign purchasers to whom they are consigned. The plan is to have inspectors attached to every Japanese export guild. American exporters have been accused of shipping inferior goods abroad and thereby injuring the marketing of products of the United States in foreign mar-

Export Managers Meet Under Auspices of N. A. C. C.

More than 40 export managers of automobile manufacturing concerns, members of the National Automobile Chamber of Commerce, Inc., met in New York City, January 12 in an export conference, the first of its kind ever held in this country.

One of the main subjects was whether U. S. makers should build special cars for export trade or whether they should sell foreign countries the U. S. standardized car. E. W. Davenport, export manager of the Maxwell Motor Co., prepared a paper which took the stand that U. S. makers have been able to produce a low-priced car of high quality because of manufacturing but one model. If it were necessary to build another model for export or to modify the existing one, that would add to the expense and make it necessary to sell at a higher figure, thereby, to an extent, sacrificing part of the great advantage gained in production.

The consensus of opinion was that a committee should be appointed to draft resolutions to the N. A. C. C. Sentiment favored the idea of selling the U. S. car which lists at less than \$1,000 in the U. S. in essentially its present form to foreign countries. There is practically no foreign competition for a car of this price and consequently little necessity for remaking it for export trade, particularly when remaking it means higher prices.

On the other hand, those American cars selling between \$1,500 and \$3,000, which have foreign competition in their fields, will have to be modified as necessary to meet trade conditions. Color options and other options are liberally given in the home market and they will have to be extended to the foreign dealer. Many makers feel they should give 60 in. tread, as German, Italian, French and English makers are offering such inducements. Right-hand steering must be given in both classes and the majority of manufacturers are agreed on this. The question of necessary clearance is also a debatable one.

U. S. manufacturers have generally agreed to discontinue the manufacture of 60 in. tread for export work, this action dating as of January 1, 1917. It was agreed that an educational movement for road improvement in foreign countries should be favored and that manufacturers and associations should lend their support to such a movement.

China as a foreign market was analyzed by Charles Denby, export manager of the Hupp Motor Car Co., who has spent many years in that country. Mr. Denby considered China one of the greatest future fields for the automobile. Before the automobile will take hold it will be essential to build roads, which should be encouraged by the American industry.

David Beecroft made several recommendations as to the best method of capturing the South American trade. Argentina, one of the greatest South American fields, is badly in need of roads, and to stimulate this movement the U. S. manufacturers should institute a road improvement propaganda for that country. Influential members of our different companies should visit and become acquainted with the South American field. A better service covering the electrical equipment of U. S. cars is needed in the Argentine field. Electric starting, lighting and battery ignition are entirely local to U. S. so far as invention and manufacture are concerned. Because of this U. S. makers should furnish expert service assistance for edu-

cating the dealers in South America. In several foreign countries, and also in the Philippine Islands, there has been much opposition to battery ignition and U. S. makers have had to equip their cars with magnetos for such trade. Investigations have revealed the fact that the opposition to battery system has largely been one of ignorance which could to an extent be overcome by such an educational service plan.

For the South American trade it is essential to have an adequate supply of spare parts at such centers as Buenos Aires and Rio de Janeiro. The U. S. maker must allot a certain percentage of his output for foreign dealers, and their shipments must go forward as regularly as home shipments.

The subject of catalogs in foreign languages, as well as instruction books, etc., was discussed by F. B. Amos, foreign advertising manager of the Studebaker Corporation, who suggested the necessity of not only securing the best translators but paying them a fair price. Cheap translations generally are a boomerang. Wrong words are used and entirely wrong conceptions given. Literature for foreign countries must be well illustrated, particularly for Latin countries. The text must be short and direct but not so concise as for U. S. literature. Bombastic statements are not in good order in foreign countries where they are misinterpreted. Mr. Amos suggested that advertisements for foreign countries should be left in the hands of the foreign dealer. Instruction books in different foreign languages should go forward with the first shipment of cars, a practice followed by France and Germany.

The ins and outs of crating cars for export was handled by M. J. Budlong, of Gaston, Williams & Wigmore, exporting organization of New York City. He told the necessity of closely checking the crating of cars for export. On one shipment of 50 cars the crates were made 1 in. too high, which increased the shipping cost \$300 on the lot. The carpenters in charge had explicit instructions as to size, but close checking was necessary while the work was going on. If this crating is not closely watched many thousands of dollars will be foolishly expended each year in this way. The paper also referred to the difficulty of not properly addressing crates for the foreign trade.

Alfred Reeves, general manager of the association, presided

G.M.C. Has Assembly System

The General Motors Truck Co. at its plant in Pontiac, Mich., has adopted the track method of assembling machines. This is the first instance where a truck manufacturer has adapted that system to turning out its product. It was previously thought that because of the heavier construction and more attention in assembling believed to be required, the system that is so generally used in constructing light pleasure cars could not be applied. But the truck chassis at the Pontiac plant roll off the assembling tracks, receive a supply of fuel, water and oil and are driven to the testing stations.

Bound Brook Promotes Smith

A. K. Smith has been made production manager of the Bound Brook Oil-Less Bearing Co., Bound Brook, N. J. He came to the company three years ago from the American Engine & Electric Co. and his promotion is in recognition of his valuable services.

Death of George H. Babcock

George H. Babcock, president and treasurer of the H. H. Babcock Co., Watertown, N. Y., died December 19 at his home in that city, following an illness of over a year, aged 64. He had been in failing health for over a year and since August 11 had been in bed.

Mr. Babcock was born in Watertown, receiving his education in the public schools of that city, and in 1870 he became a clerk in a bank, which position he continued until the latter part of 1871 when he was taken into his father's business, then the H. H. Babcock & Sons, manufacturers of pumps. In 1882 a corporation was formed known as the H. H. Babcock Co., consisting of H. H.



Babcock, and his three sons, Herbert P., George H., and Fred W. Babcock, capitalized at \$100,000, and the manufacture of carriages was started. Since that time the concern had been one of the leading manufacturing concerns in Watertown, and the fame of the Babcock carriages was known from coast to coast. This business later developed into the manufacture of automobiles and of late the manufacture of delivery wagon bodies. George H. Babcock was elected treasurer of the company, and in 1903, on the death of his father, he became president.

Mr. Babcock took an active interest in the Carriage Builders' National Association and was president of that organization in 1897-98.

Besides being a director of several banks, he took an active part in local church and social affairs, being one of the governors of the Black River Valley Club and a governor of the Jefferson County Golf Club.

Mr. Babcock was an energetic, hard working man and his health was broken by the strenuous work of his earlier years. He was most affable, kindly hearted and capable and his friendships were true and lasting. He was one of the builders of Watertown, giving his time generously to its service.

He is survived by his widow, one brother, Frank E., and a sister.

Subscribe, now, to The Hub

A Growing Institution

The fall term of the Technical School for Automobile Draftsmen and Mechanics which closed on December 21, was the most successful in the history of that institution. Attendance in the day class was almost perfect. Attendance in the evening class was 87 per cent. Every available seat for the winter term is occupied by students and there are numbers waiting to enter but are not able for lack of room. The splendid success of the men who graduated from this school is an incentive for young men to attend the school and secure its advantages.

The winter term is from January 2 to April 11 inclusive. The correspondence department is open the year round.

All inquiries should be addressed to the instructor, Andrew F. Johnson, 20 West 44th Street, New York City.

Laidlaw in New Building

The Laidlaw Co., Inc., manufacturer and importer of automobile top materials and enclosed linings, reports that after many disappointments and delays it has at last taken possession of its new six-story building at 16 and 18 West 60th street, N. Y. City, right in the heart of the automobile district. The new building is so designed and equipped that the handling of the company's business may be facilitated and expedited so that "Laidlaw Service" will become an even greater factor in the automobile industry than heretofore.

Now the E. D. Gear Mfg. Co., Inc.

The Eadie Vehicle Gear Co., New York, has been taken over by the E. D. Gear Mfg. Co., Inc., and has installed a plant at Westfield, N. Y., for the manufacture and sale of the "E. D." automatic short turning and tracking devices for trailers, railway, factory and store hand trucks, toy wagons and horse-drawn vehicles. John M. Eadie, inventor of the gear, as vice-president and general manager, will personally supervise the production of the factory.

Studebaker Buys Staver Plant

The Studebaker Corporation has completed the purchase of the Staver Carriage Co. plant in Chicago, and will use it for assembling automobiles. This plant covers the block between West 76th and West 77th streets, between the Rock Island Lines on the east and the Chicago Belt Lines on the west. The buildings are four stories and contain approximately 300,000 sq. ft. of floor space.

O'Bannon Buys International Rubber

The O'Bannon Corporation announces that it has purchased the good will and processes of the International Rubber Co., also the plant and machinery of the company at West Barrington, L. I., along with the principal part of its merchandise and fixtures.

U. S. Fiat Absorbed by Italian Company

The Fiat Co., of Poughkeepsie, N. Y., has been taken over by the home factory of the Fiat Co., Turin, Italy, according to reports in Italy. It is understood that some of the heaviest stockholders in the U. S. A. Fiat factory retain their interest. J. S. Josephs, treasurer, retains his interest.

Trade News From Near and Far

General News of the Vehicle Trade

The Russell Motor Car Co., Toronto, Ont., will erect a boiler house on Mowat avenue, to cost \$2,000.

The Piedmont Motor Co., Lynchburg, Va., is planning the construction of an automobile assembling plant.

The American Bow Socket Co., Ashtabula, O., is enlarging its forge department by the erection of a building 56 x 60 ft.

The Sherwin-Williams Co. has plans for a three-story brick factory at 542-544 Kensington avenue, Chicago, at a cost of \$25 000.

The Fuller & Sons Mfg. Co., builder of automobile parts, Kalamazoo, Mich., is purchasing some machinery for its new plant.

The American Forging Co., Birmingham, Ala., will install apparatus for making automobile forgings. R. I. Ingalls is president.

The Atlas Bolt & Screw Co., Cleveland, O., which will shortly begin the erection of a new plant, has increased its capital stock from \$200,000 to \$500,000.

The Walker Mfg. Co., Racine, Wis., manufacturer of automobile parts and tools, has commenced the installation of equipment in its new plant, and expects to begin operations before January 15.

The Monitor Motor Car Co., Columbus, O., is increasing the capacity of its plant for the manufacture of automobiles. It is capitalized at \$1,000,000 and its present output is 3,000 cars per annum.

The Dixie Motor Car Co., Louisville, Ky., manufacturing an automobile in connection with the Kentucky Wagon Mfg. Co., has increased its capital from \$150,000 to \$400,000. L. V. Board is president.

The foundry now under construction for the Standard Wheel Co., Terre Haute, Ind., will be for the manufacture of malleable iron castings for wheels and automobile hubs. It will be completed about February 1.

The Rosedale Motors, Ltd., Toronto, Ont., has been incorporated with a capital stock of \$200 000 by Walter G. Hammond, 24 King street west; Alexander McInnes, and others to manufacture automobiles, trucks, etc.

The Dayton Wire Wheel Co., Dayton, O., recently incorporated, has arranged for the purchase of the Pinneo & Daniels Co.'s plant in Edgemont, a suburb, and will soon install additional machinery to manufacture wire wheels.

The Gibbons Motor Car Co., Ltd., Toronto, Ont., has been incorporated with a capital stock of \$100,000, by Samuel H. Gibbons, 35 Conduit street; John W. Franks, 491 Palmerston avenue, and others, to manufacture automobiles, parts, etc.

The Climax Shock Absorber Co., Benton Harbor, Mich., has been organized to manufacture shock absorbers and other automobile accessories. The stockholders are William A. Vawter, St. Joseph, Mich.; William A. Vawter, Jr., and John Steiner, Benton Harbor.

The Colton Demountable Rim Corporation has been incorporated at Dover, Del., with a capital of \$2,500,000, to manufacture rims for automobiles. L. B. Sheldon and L. N. Downs, New York City, and George H. Roeder, Brooklyn, N. Y., are the incorporators.

The Federal Automobile & Supply Co., Camden, N. J., has been incorporated with a capital of \$100,000, to manufacture motor vehicles and equipment. Charles M. Reeves, Camden; William A. Walton, Oxford, and Thomas R. Roberts, Philadelphia, are the incorporators.

The Hayes Wheel Works, Chatham, Ont., will be converted into a munitions plant. The British government has awarded a contract to the company for the manufacture of 50,000 shells to be completed before June 1. Additions will also be made to adapt the plant to this work.

The Davis Mfg. Co., Milwaukee, manufacturer of gasoline engines and power units for automobiles, trucks, etc., is reported to be preparing to make large additions to its works at 57th avenue and Mitchell street, in West Allis, erected less than two years ago. Tentative plans are said to have been completed for a one-story brick and steel shop, 124 x 225 ft., and a new pattern shop, 24 x 90 ft. Frank W. Davis is president and general manager.

The Herschell-Spillman Co., North Tonawanda, N. Y., manufacturer of gasoline motors, has increased its capital stock from \$250,000 to \$750,000. The company will pay a 100 per cent stock dividend December 30 and in addition a regular quarterly cash dividend of 2 per cent. The balance of the increased capital will be used to enlarge its present facilities. The company has just completed the construction of a four-story addition, 65 x 165 ft., for handling increased business. Guy White is vice-president and general manager.

Doings of the Motor Truck Builders

The capital of the Gary (Ind.) Motor Truck Co. has been increased from \$25,000 to \$50,000.

The United States Truck Corporation has been incorporated at Dover, Del., with capital stock of \$5,000,000.

The Forschler Motor Truck Mfg. Co., New Orleans, La., has plans for the erection of a motor truck manufacturing plant.

The United Motors Co., Grand Rapids, Mich., manufacturer of United trucks, has appointed A. R. Ruggles factory manager.

The Manly Motor Truck Co. has purchased a factory in Waukegan, Ill., where the company will move its manufacturing operations.

The Republic Motor Truck Co. has purchased the plant of the Little Giant Hay Press Co. at Alma, Mich., and will use it for an axle plant.

The Moreland Motor Truck Co., of which Watt Moreland is founder and treasurer, is planning a \$1,000,000 plant to be erected in Los Angeles, Cal.

The Evans Truck Mfg. Co., Detroit, has been incor-

porated for \$10,000 by Robert H. Evans, 962 Bush street; William M. Darling and Alvin Patterson.

Continental Motor Truck Co., Superior, Wis., has completed work on its new factory and machine shop and is now erecting and equipping a power house.

The Winther Motor Truck Co., Kenosha, Wis., is placing orders for a complete equipment of machine tools, etc., for its proposed factory, to be erected in the spring. Martin P. Winther is president.

An order for 100 "Truck-Maker" units was recently placed with the Redden Motor Truck Co., New York City, by the Ward Baking Co. of that city, at the conclusion of a 30-day trial of a single unit.

The B. & M. Truck Co., Connersville, Ind., has been incorporated with \$10,000 capital stock to manufacture motor vehicles. The directors are Alfred H. McFlarian, Burton M. Barrows and Arthur Dixon.

Robert H. Hassler, Edward D. Fouts and David G. Ong are the directors of the Hassler Motor Co., of Indianapolis, Ind., recently incorporated; capital \$200,000. The company will manufacture automobiles and motor trucks.

The Marion (Ind.) Truck Corporation has been incorporated with a capitalization of \$1,000,000, to manufacture motor vehicles. The directors of the company are C. G. Barley, J. W. Stephenson, S. W. Winder, and G. C. Harwood.

While the manufacturing facilities of the Federal Motor Truck Co., Detroit, have been doubled during the past year, plans are under way to construct another large assembling plant that production may be further increased during 1917.

The front drive Erickson trucks, designed by C. A. Erickson, formerly chief engineer of the Scripps-Booth Co., will be placed in the market in the near future. They are being made by the Jacobson Machine Mfg. Co., of Warren, Pa.

The Canada Truck Co., Ltd., Montreal, Que., has been incorporated with a capital stock of \$49,000, by Richard E. Hannan, John W. Blair, and Francis J. Laverty, all of Westmount, Que.; Charles A. Hale, Montreal, and others, to manufacture motor trucks, etc.

The Martin Truck & Body Corporation, Millbrook, N. Y., capital \$450,000, has been incorporated by Hiram Thompson, East Orange, N. J.; S. C. T. Dodd, 1918 Avenue H, Brooklyn, N. Y.; Harlan S. Parrigo, 660 St. Nicholas avenue, New York City.

The Landover Auto Truck Co. has filed a charter at Dover, Del., to deal in and with attachments for automobiles and auto trucks. The company is capitalized for \$300,000 and the incorporators are Arthur W. Britton, Samuel R. Howard and L. H. Gunther, all of New York City.

The Clyde Motor Truck Co., Farmingdale, N. Y., has changed its name to the Fulton Motor Truck Co., and the truck will be known as the Fulton. Production is already under way. About 30 trucks are to be made the first month, increasing each month until a total of 1,000 has been reached for the 1917 calendar year.

Two truck models of 1¼ and 2 tons capacity will be marketed about February by the Bethlehem Motors Corp., Allentown, Pa. A new plant, to have a floor space of 199,000 sq. ft., is being built. The concern has a capital of \$6,000,000. Arthur T. Murray, formerly of the Brady-

Murray Motors Corporation, local Chandler dealer, is president.

The production at the plant of the Four Wheel Drive Co., Clintonville, Wis., has been increased to six trucks a day. Additions to the plant are being rushed and new equipment is being installed as fast as it can be secured. With a standing order for 20 trucks daily for export business and a large domestic demand the company is way behind on deliveries.

The Duplex Motor Truck Co. has bought 15 acres of land in Lansing, Mich., and will start at once construction of a new plant, 800 x 60 ft. About ten trucks a day will be built. At present the company is operating in a plant in Charlotte, Mich., in which \$50,000 worth of machinery has been installed. When the new plant is finished the equipment of the Charlotte plant will be moved into it.

The Corbitt Motor Truck Co. succeeds The Corbitt Automobile Co., at Henderson, S. C. The new company is incorporated on a million dollar basis. Seven years ago the company commenced making pleasure automobiles but after three years began the manufacture of motor trucks and has since discontinued making pleasure vehicles, hence the change in name. The Corbitt company makes a full line of ¾ and 5-ton trucks, all worm drive and standard units.

The Pull-More Truck Co. has been organized in Pittsburgh, Pa., with offices in the Frick Annex. Building operations on a new plant will be started immediately. Edward M. S. Young is president; H. P. Bope, vice-president; John M. Richards, general manager. Prominent steel men interested in the organization are: B. G. Follansbee, president of the Follansbee Bros.; D. M. Clemson, director of the Carnegie Steel Co.; J. W. Kinnear, director of the Firth-Sterling Steel Co.; George Greer, chairman, La Belle Iron Works.

The Champion Motor Co. will establish a factory at Fulton, Ill., for the manufacture of light delivery trucks. The company was recently organized by Cleveland interests, with capital of \$5,000,000, and will manufacture a 1,000 lb. and 1,500 lb. delivery chassis which will be sold for \$750 and \$775 respectively, equipped with electric starting and lighting system, bumpers, side curtains and other accessories. W. L. Widlar is president; N. R. Wildman, vice-president; Wm. Grief, secretary and treasurer, and H. D. W. Mackaye, a vice-president, has charge of production.

Two trucks are now offered by the Metz Co., Waltham, Mass., manufacturer of the Metz friction-drive car. In addition to the half-ton truck, which is an adaptation of the pleasure car chassis and costs from \$500 to \$600, a one-ton machine has been brought out that is of special construction and sells for \$695. The transmission is of the same friction type as that of the other Metz models, with seven speeds, but final drive is through internal gears direct to each rear wheel. The wheelbase is 130 in. Front tires are pneumatic, 32 x 3½, and rear tires, solid, 34 x 3½; maximum speed is 20 miles an hour and the truck weighs 2,500 pounds.

The Maxwell Motor Co. has announced the new Maxwell worm driven one-ton truck, which will sell for \$760 f. o. b. Detroit. Three body styles will be fitted to the chassis, a cupboard express body, a screened express body and an open flareboard express body at \$80, \$85 and \$45 respectively. The chassis price includes lamps, horn, fenders, seat and other necessary equipment except the bodies,

which are extra as quoted. The chassis has a wheelbase of 124 in. and is fitted with a unit power plant, including a block type four-cylinder motor with $3\frac{5}{8}$ in. bore and $4\frac{1}{2}$ in. stroke. The power transmission is through a three-speed ratio gearset and a two-piece propeller shaft with two universal joints. The conventional type of worm gear is used with the Hotchkiss drive through the springs. The rear axle is of the three-quarter floating type. The front tires are 32×3 in. and rear $32 \times 3\frac{1}{2}$ in.

Body Builders Briefs

In order to take care of its increased business, Locke & Co., the New York City body maker, has increased its capital stock from \$75,000 to \$150,000. The company is one of the best known of the makers of custom bodies in New York City.

The Allen Motor Co., Fostoria, O., which already manufactures its own engines, gearsets and tops and finishes its bodies, has gone a step further and is building its own closed bodies in a factory at Fostoria. Later it will build open bodies as well.

The National Body & Trimming Co., Detroit, has been incorporated by A. Cornelius Knapp, Thomas J. Gillan and Joseph M. Ackerson, of Detroit, with capital stock of \$100,000. The company will manufacture automobile bodies, tops and trimmings.

During November the sales of the Fisher Body Corporation, Detroit, totaled \$1,650,000, an increase of about \$180,000 over the month of October and of about \$400,000 over any previous month in the current fiscal year. Total sales for the last nine months have increased 65 per cent over the same period of last year.

Dan Kidney & Sons, DePere, Wis., one of the largest builders of motor boats in the northwest, has installed equipment for the production of automobile and truck bodies to keep the plant fully engaged during the usual winter slack season. The company is specializing in closed bodies for passenger cars and has order enough to keep occupied until mid-summer.

The Union Truck Co., Bay City, Mich., has leased the old plant of the Pioneer Boat Co., in that city, and will manufacture its own commercial automobile bodies. The new light commercial body being manufactured by W. H. Kelly, Bay City, backed by a syndicate of business men, has been well received by the trade and the company is manufacturing many bodies.

With the first of the year the Kentucky Wagon Mfg. Co. began operations in its automobile body department, in a large addition to its plant which has just been completed. Here the company will make not only bodies for the Dixie automobiles, but bodies for other pleasure cars, having already contracts for touring car bodies and closed bodies for manufacturers of automobiles. The company recently increased its capital to \$400,000 to take care of expanding business.

The Corcoran Mfg. Co., Cincinnati, O., maker of automobile bodies, fenders, hoods and radiators, has bought the properties of the Jacob Freund Roofing Co. and the Cincinnati Tile and Terra Cotta Co., and is planning the construction of a fireproof building of four stories, 472×76 ft., to be used for the exclusive manufacture of automobile bodies. This will give employment to 500 men and will cost approximately \$125,000. When the company was formed, about six months ago, the result of the sale

of the present officers' interest in the Corcoran and Victor corporations, it leased the manufacturing property at Winton place. This lease does not expire for three years, at which time the company will erect a duplicate of the building now to be built, which will make the total plant area approximately 275,000 sq. ft.

Death of Prominent French Coach Builder

The Hub has received the announcement of the death of Georges Kellner, Chevalier of the Legion of Honor, at his home 129 Avenue de Malakoff, Paris, on December 12. The deceased, for many years one of Europe's leading coach builders, was an honorary member of the Carriage Builders' National Association of the United States, and a former president of the French National Carriage Builders' Association.

Mr. Kellner was born in Austria and when a young man went to Paris to improve himself in the art of coach building. About 1860 he established himself there as a coach builder. The business having grown to a considerable size, about 1890 he took his two sons into partnership with him.

Mr. Kellner's establishment obtained a reputation throughout Europe for the excellence of its work and built many coaches for Turkish royalty and nobility.

With the advent of the automobile the Kellner factory began to build bodies, which were generally in advance of any others made in Europe or elsewhere. Soon extensive enlargements of the plant became necessary, and the great plant at Billancourt was erected, just outside of Paris on the Versailles road.

A few years ago Mr. Kellner donated \$5,000 to the Coachbuilders' Technical and Drafting School, situated on the Rue Desrenaudes, Paris, where about 150 apprentices and mechanics are taught yearly.

Two of his sons are in charge of the two plants, one on the Avenue Malakoff and the other at Billancourt. The sons who manager both establishments, building automobiles for France and many foreign countries, are well known in this country.

Death of Frederick L. Harral

Frederick L. Harral, son of Major W. W. Harral and nephew of E. W., formerly of the Fairfield (Conn.) Rubber Co., died December 24, following three days of illness from paralysis, at his home in Mt. Vernon, N. Y., aged 53 years. His widow and a brother survive.

F. J. Enger Dead

F. J. Enger, president of the Enger Motor Car Co., Cincinnati, O., shot and killed himself in his office at the factory January 4. Mr. Enger has been in ill health for a long time. He was 58 years old.

A Busy Corner

More than 17,150 vehicles pass Fifth avenue and Forty-second street, New York City, going north and south daily. If the east and west traffic be added, the total of vehicles passing the intersection of these two thoroughfares exceeds 25,000, which is an increase of more than 1,000 a day as compared with last year. During the rush hour which is between 3 and 4 o'clock, when the shoppers begin to return home, more than 2,500 vehicles an hour pass in Fifth avenue.

Death of F. D. Hotchkiss

Frank DeWitt Hotchkiss, for 28 years manager of the Fairfield (Conn.) Rubber Co., now the DuPont Fabrikoid Co., died December 23, as the result of long suffering with liver trouble. He was 68 years of age.

Mr. Hotchkiss' father was one of the leading manufacturers of Naugatuck, being one of the founders of the Goodyear Rubber Co., of that place. The son was associated with his father in Naugatuck, and upon the death of the latter left for Boston where he became connected with the American Rubber Co. From Boston he moved to Fairfield.

Mr. Hotchkiss is survived by his wife, three daughters and two sons.

Death of C. J. Reynolds

C. J. Reynolds, purchasing agent for the Studebaker Corporation, Detroit, died December 24 at his home, of heart disease. He was one of the oldest men in point of service with the Studebaker forces, having been with the company for 30 years. Starting in a minor position, his business ability brought him increasing responsibilities, until in May, 1912, he was placed at the head of purchases for the automobile division.

Death of Robert H. Thomas, Jr.

Robert H. Thomas, Jr., vice-president and director of the D. Wilcox Mfg. Co., Mechanicsburg, Pa., died December 20 at his home in that city, aged 54. Mr. Thomas was taken with a severe cold on December 11, which developed into pneumonia.

Mr. Thomas, besides his connection with the D. Wilcox Mfg. Co., was interested in several other enterprises. He had also held several elective and appointive offices in Mechanicsburg.

Henry Luedinghaus, Sr., Dead

Henry Luedinghaus, Sr., one of St. Louis' oldest and most prominent business men, president of the long established Luedinghaus-Espenschied Wagon Co., died at 6:35 o'clock, Christmas night at his home, 2831 Rauschenbach avenue, St. Louis, Mo.

WANTS

Help and situation wanted advertisements, 1 cent a word; all other advertisements in this department, 5 cents a word; initials and figures count as words. Minimum price, 30 cents for each advertisement.

PATENTS

Patents—H. W. T. Jenner, patent attorney and mechanical expert, 606 F St., Washington, D. C. Established 1883. I make a free examination and report if a patent can be had and exactly what it will cost. Send for circular.

FOR SALE

For Sale—"Motor Body Work for Commercial Cars," a new text book dealing with the construction of all types of bodies for business purposes. Contains also six working drawings and a glossary of technical terms, together with diagrams and sketches. Price, \$1.20 net; by post, \$1.56. Orders should be accompanied by remittance. Cooper's Vehicle Journal, Ltd., 19 Garrick street, Long Acre, London, England.

Index To Advertisers

Acme Die-Casting Corporation.....	38
Barrell Co., Wm. L.....	4
Bliss, E. W. Co.....	2
Bookwalter Wheel Co.....	42
Bradley, C. C., & Son.....	41
Brawley, T. R.....	4
Brennan Motor Mfg. Co.....	43
Cargill Co., The.....	40
Columbus Bolt Works.....	Back cover
Cowles, C., & Co.....	42
Crane & MacMahon, Inc.....	Back cover
Decker, J. C.....	42
Dowler, Chas. L.....	42
DuPont Fabrikoid Co.....	6
Eccles, Richard, Co.....	40
Fairfield Rubber Co.....	43
Felton, Sibley & Co., Inc.....	Back cover
Harrison Mfg. Co., The, Inc.....	7
Hoopes Bro. & Darlington.....	43
Hotel Brunswick	41
Hotel Cumberland	38
Hotel Tuller	39
Jenner, H. W. T.....	37
Johnston Paint Co.....	42
Keratol Co., The.....	4
Laidlaw Co., The.....	4
Lumen Bearing Co.....	8
Millersburg Fifth Wheel Co.....	42
Mulholland Co., The.....	42
Murcott-Duden Co., The.....	2
Parsons Mfg. Co.....	42
Porter, H. K.....	43
Pressed Steel Co. of New York.....	2
Rome-Turney Radiator Co.....	38
Russell, Burdsall & Ward Bolt & Nut Co.....	41
Sheldon Axle & Spring Co.....	Front cover
Skinner, J. M., Bending Co., The.....	39
Smith, H. Collier.....	43
Standard Oil Cloth Co., Inc.....	5
Sherwin-Williams Co., The.....	39
Technical School for Automobile Draftsmen.....	41
West Tire Setter Co.....	43
White-Quehl Mfg. Co.....	42
Wilcox Mfg. Co., D.....	43
Willey Co., C. A.....	42
Williams, J. H., & Co.....	8
Wing, Chas., Co.....	42

ACME Die-Castings in Aluminum

**Accurate - Strong - Tough - Smooth
Low in Cost**

There are special features in the Acme patented process of die-casting intricate parts in aluminum that are important to manufacturers. Porosity is reduced. Strong, tough, smoothly finished, accurate castings are the result of our expert knowledge of this work.

The cost of aluminum die-casting in quantities cast by the Acme process is low when compared with former methods of production.

Our wonderful equipment and thorough organization enables us to give you highly satisfactory service. Let us give you estimates at once from your model or blue prints.



Acme Die-Casting Corporation
 Bush Terminal Bldg. No. 37th St. and 3d Ave.
 BROOKLYN, N. Y.

Boston— 176 Federal St.
 Philadelphia— Widener Bldg.
 Detroit— 965 Woodward Ave.
 Chicago— 549 Wash. Blvd

CANADIAN DISTRIBUTORS:
 Lyman Tube & Supply Co., Ltd., Montreal

ROME-TURNEY

units represent extremely advanced engineering. We have built radiators of all types for 14 years and are specialists in designs developed for truck construction. No better radiators can be built. If this were possible we would build them.

"RADIATOR INSURANCE"

**SEAMLESS COPPER HELICAL
TUBE COOLING SECTIONS**

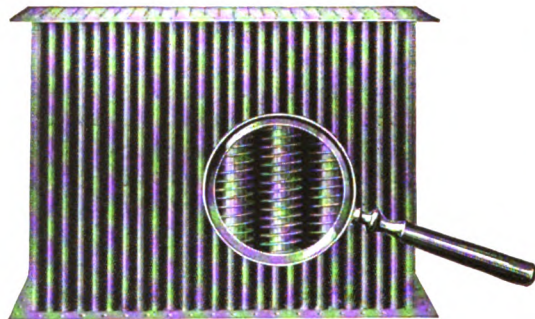

Are Guaranteed for the Life of the Motor on Which They are Installed

Helical Tube Construction is Accepted as the Best by the Leading Truck Makers of America

MANUFACTURED ONLY BY
ROME-TURNEY RADIATOR COMPANY
 ROME, NEW YORK

HOTEL CUMBERLAND

NEW YORK

Broadway at 54th Street

Near 50th Street Subway Station and 53d Street L



Broadway Cars from Grand Central Depot.

Seventh Avenue Cars from Pennsylvania Station.

NEW AND FIRE-PROOF

Best Hotel Accommodations in New York at Reasonable Rates.

\$2.50 with Bath and Up

EUROPEAN PLAN

All Hardwood Floors and Oriental Rugs.

Ten Minutes' Walk to 40 Theatres

Excellent Restaurant. Prices Moderate. Send for Booklet.

HARRY P. STIMSON

Only New York Hotel window-screened throughout

When you install a
HELICAL TUBE RADIATOR
 on your truck, you have the certainty that the radiator will make good or we will. We probably won't have to—
ROME-TURNEY RADIATORS
 have a habit of making good themselves. But if the cooling section develops leaks, we will repair it free.

High Grade Forgings

for CARRIAGE, WAGON, AUTO-MOBILE and SPECIAL WORK

ECCLES BALL-BEARING COUPLINGS are the BEST on the MARKET for DURABILITY and EASE OF ADJUSTMENT

LEATHER BUSHINGS ARE FASTENED IN THE SOCKET WHERE THEY BELONG

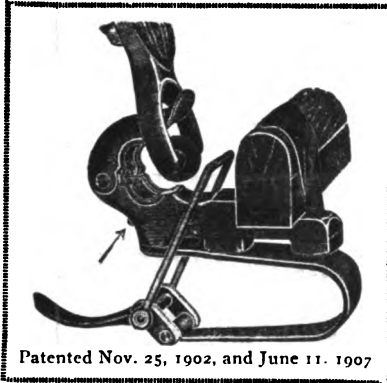

Patented Nov. 25, 1902, and June 11, 1907

SPECIAL FEATURE—THE SPRING IS PIVOTED AT THE FRONT TO ALLOW EASY ADJUSTMENT

Please bear in mind that we make a FULL LINE of Carriage and Wagon Forgings, also many of those for Auto and Special Work.

Send for our new Catalogs showing our Regular and Special Forgings.

QUALITY GUARANTEED.

SERVICE—THE BEST

Richard Eccles Co.
AUBURN, NEW YORK

Catalog Building

Is similar to that of other products. The raw materials, *plus* expert designing, *plus* competent workmanship, *plus* the know how (and we have had over twenty-five years of the latter), *equal* the finished article.

The Cargill Company

Complete Printing Service

Grand Rapids, Michigan

CLASSIFIED INDEX

For Addresses See Alphabetical Index
and Advertising Pages

AUTO FABRICS

Acme Rubber Mfg. Co., Trenton, N. J.
Barrell, Wm. L., Co., New York
Fairfield Rubber Co., Fairfield, Conn.
Keratol Co., The, Newark, N. J.
Laidlaw Co., Inc., The, New York
O'Bannon Corporation, New York City
Standard Oil Cloth Co., New York City

AXLES (Including Ball and Roller Bearing)

Sheldon Axle & Spring Co., Wilkes-Barre, Pa.

BOLTS AND NUTS

Columbus (O.) Bolt Works Co.
Russell, Burdall & Ward Bolt & Nut Co., Port Chester, N.Y.

BOLT CLIPPERS

Porter, H. K., Everett, Mass.

BRAZING SLEEVES

White-Quehl Mfg. Co., Cincinnati, O.

BRONZE BEARINGS

Lumen Bearing Co., Buffalo.

DIES

Bliss Co., E. W., Brooklyn, N.Y. (Sheet Metal Working).

FORGINGS

Eccles, Richard, Auburn, N. Y. (Carriage, Drop).
Williams, J. H., & Co. Brooklyn, N.Y. (Automobile, Drop)

DIE CASTINGS

Acme Die Casting Corp., Brooklyn, N. Y.

FIFTH WHEELS

Millersburg Fifth Wheel Co., The, Millersburg, Pa.
Wilcox Mfg. Co., D., Mechanicsburg, Pa.

HARDWARE (Carriage, Wagon and Automobile)

Columbus (O.) Bolt Works Co.
Dowler, Chas. L., Philadelphia.
Eccles Co., Richard, Auburn, N. Y.
Wilcox Mfg. Co., D., Mechanicsburg, Pa.
Wing Co., Chas., Amesbury, Mass.
Cowles, C., & Co., New Haven, Conn.
Parsons Mfg. Co., Detroit, Mich.
Payne Co., E. Scott, Baltimore.

LEATHER SUBSTITUTES

Barrell Co., Wm. L., New York
Keratol Co., The, Newark, N. J.
O'Bannon Corp., New York
Standard Oil Cloth Co., New York
DuPont Fabrikoid Co., Wilmington, Del.

MACHINERY AND TOOLS

Bliss Co., E. W., Brooklyn, N.Y.
Smith, H. Collier, Detroit, Mich.
West Tire Setter Co., Rochester, N. Y.
Williams, J. H., & Co., Brooklyn, N. Y.
White-Quehl Mfg. Co., Cincinnati, O.

MACHINERY (Metal Working)

Bliss Co., E. W., Brooklyn, N.Y.
Smith, H. Collier, Detroit, Mich.

METAL STAMPINGS AND NOVELTIES

Murcott-Duden Co., Inc., New York
Pressed Steel Co. of New York, New York City.

MOTORS

Brennan Motor Mfg. Co. Syracuse, N. Y.

PATENTS

Jenner, H. W. T., Washington, D. C.

PAINTS AND COLORS

Felton, Sibley & Co., Inc., Philadelphia, Pa.
Johnston Paint Co., R. F., Cincinnati, O.
Pierce Co., F. O., New York
Sherwin-Williams Co., Cleveland, O.
Valentine & Company, 456 4th Ave., New York; 343 S. Dearborn St., Chicago; 74 Pearl St., Boston.
Willey Co., C. A., Hunter's Point, N. Y.

PASTE

Indianapolis (Ind.) Paste Co.

PRESSES

Bliss Co., E. W., Brooklyn, N.Y. (Drop, Power).

RADIATORS

Harrison Mfg. Co., Inc., The, Lockport, N. Y.
Rome-Turney Co., Rome, N. Y.

SCHOOL FOR DRAUGHTSMEN

Mechanics' Institute, New York

SHAFT COUPLINGS

Bradley & Son, C. C., Syracuse, N. Y.
Eccles Co., Richard, Auburn, N. Y.

SPRINGS

Mulholland Co., Dunkirk, N. Y.
Sheldon Axle & Spring Co., Wilkes-Barre, Pa.

THREADS

Meyer, Jno. C. & Co., Lowell, Mass.

TOOLS

Williams, J. H., & Co. Brooklyn, N. Y.

VARNISH AND JAPAN

Felton, Sibley & Co., Inc., Philadelphia, Pa.
Parrott Varnish Co., Bridgeport, Conn.
Pierce Co., F. O., New York
Sherwin-Williams Co., Cleveland, O.
Valentine & Company, 456 4th Ave., New York; 343 S. Dearborn St., Chicago; 74 Pearl St., Boston.
Willey Co., C. A., Hunter's Point, N. Y.

WHEELS

Bookwalter Wheel Co., Miami-burg, O.
Crane & MacMahon, Inc., New York City.
Hoopes Bros. & Darlington, Inc., West Chester, Pa.
Smith Wheel, Inc., [Metal], Syracuse, N. Y.
Zwick & Greenwald Wheel Co., Dayton, O.

WOOD BENDINGS, WHEEL STOCK, ETC.

Columbus (O.) Bending Co.
Crane & MacMahon, Inc., New York City.
Skinner Bending Co., J. M., Toledo, O.

Please mention "The Hub" when you write

BUSY BUYERS BRIEFS

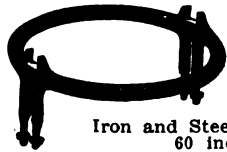

Manufacturers
FIFTH WHEELS
All Varieties
Heavy Goods a
Specialty
Iron and Steel Rings from 4 to
60 inches wide
MILLERSBURG FIFTH WHEEL CO.
Millersburg, Pa.

WE MANUFACTURE
FINE VEHICLE
WHEELS
The Bookwalter Wheel Co.
MIAMISBURG, OHIO

**JOHNSTON'S
KRAKNO**
Color Card Free
\$3.50 per gallon
The R. F. Johnston Paint Co.
Cincinnati, Ohio

Why Not Have the Best?

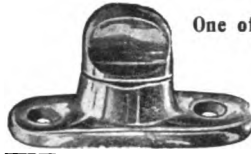

One of a Large Variety
C. Cowles & Co.
NEW HAVEN,
CONN.

J. C. DECKER
MONTGOMERY, PA.
Manufacturer of
Carriage, Skate and Pad Straps
Side Loops, Bridle Fronts, Tail Ties, etc.

THE CHARLES WING CO
Established 1848
Manufacturers and Wholesale Dealers in
**AUTOMOBILE AND CARRIAGE
HARDWARE AND TRIMMINGS**
AMESBURY, MASS., U. S. A.

CHARLES L. DOWLER
CARRIAGE AND WAGON HARDWARE
108 North Third St., Philadelphia, Pa.
CUSHION MANUFACTURER
Pure Stearic Acid Candles. Wheel Stock. Snow
Flake Axle Grease.

**MULHOLLAND
BUGGY SPRING**
Reduces weight of springs one-half.
Made in one size only but will fit bodies
of all widths.
Write for further particulars and prices.
THE MULHOLLAND CO. DUNKIRK, N. Y.

White's Brazing Sleeves
For applying Rubber Tires
Send for Samples.
WHITE-QUEHL MFG. CO.
431 E. Pearl St.
CINCINNATI, OHIO

Subscribe
Now for

THE HUB

**\$2.00
Per Year**

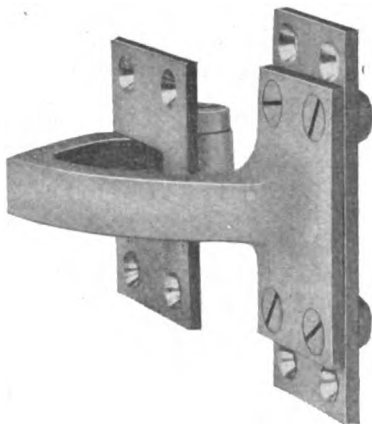

No. 44 DECK-HINGE
For Roadsters and Closed Bodies

Please note the extra body plate. Also the dowel which centers the machine screws, facilitating assembly of hinge to the body.
Another evidence of our system of improvements and suggestions on hardware articles.
We will manufacture high class hardware at less cost to you and give you prompt service.
Our No. 39 Concealed Hinge should be used on your touring bodies.



**WILLEY'S
COLORS**

The Recognized Standard



C. A. WILLEY CO.
COLOR GRINDERS

and Manufacturers of Specialties in
CARRIAGE, AUTOMOBILE and CAR

PAINTS

COLORS, VARNISHES, ETC.
HUNTER'S POINT, NEW YORK CITY

HOOPES BRO. & DARLINGTON

(INCORPORATED)

WEST CHESTER, PA.

WE ARE MAKING

AUTOMOBILE WHEELS

Forty Years' Experience as WHEEL MAKERS is guarantee we can make good ones.
Will not make any other kind. Try them.

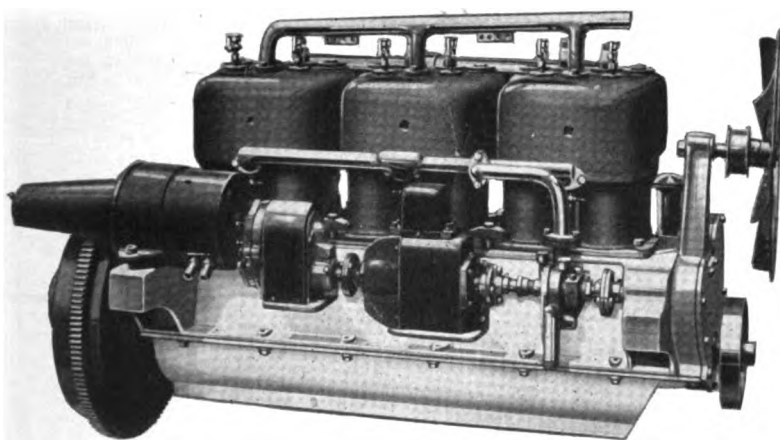

Model 6B Motor, 4½" bore by 5" stroke

Quality and Service

are the two essentials that for 17 years have been built into

BRENNAN STANDARD MOTORS

The manufacturer of Commercial or Pleasure cars who equips his product with Brennan Standard Motors can feel assured his every requirement regarding this vital part has been fulfilled.

Built in the following sizes:
4 Cylinder Model M—4 x 5 4 Cylinder Model 12—5½ x 6
4 Cylinder Model B—4½ x 5 4 Cylinder Model 12—6 x 6
4 Cylinder Model 11—5 x 5 6 Cylinder Model 6B—4½ x 5

Let us send bulletins telling WHY Brennan Motors are STANDARD motors

Brennan Motor Mfg. Co., Syracuse, N. Y.

THE FAIRFIELD RUBBER COMPANY

Manufacturers of

Carriage Cloth, Imitation Leather,
Automobile Cloths, etc.

FAIRFIELD,

CONNECTICUT

The WEST Hydraulic Tire Setter

WILL CUT DOWN EXPENSE

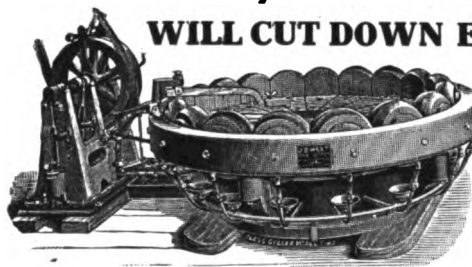

Tires set cold in one minute. This machine saves time—does the work better and quicker, does away with burned streaks. Only necessary to measure one wheel in a lot. Does not char the rim, and

thus make the tire loosen prematurely. Saves resandpapering of wheels. This machine is now increasing the profits of many manufacturers. Send for catalog and read about it.

WEST TIRE SETTER CO., ROCHESTER, NEW YORK

PORTER'S BOLT CLIPPERS

"Easy" "New Easy" Allen-Randall



To Cut 5-16, 3-8, 1-2, 5-8, 3-4 Inch.

H. K. PORTER,

EVERETT, MASS.

"Quickwork"

Sheet Metal Working Machinery

For Automobile and Carriage Bodies, Fenders, Hoods, etc.

H. COLLIER SMITH

807-815 SCOTTEN AVE.

DETROIT, MICH.

WILCOX

FINE
FINISHED
FORGED

CARRIAGE HARDWARE
AND GEAR IRONS

Write for Prices and Catalog

The D. Wilcox Mfg. Co.

MECHANICSBURG, PA.

The Hub

First Journal of the Vehicle Industry

Vol. LVIII

NEW YORK, FEBRUARY, 1917

No. 11

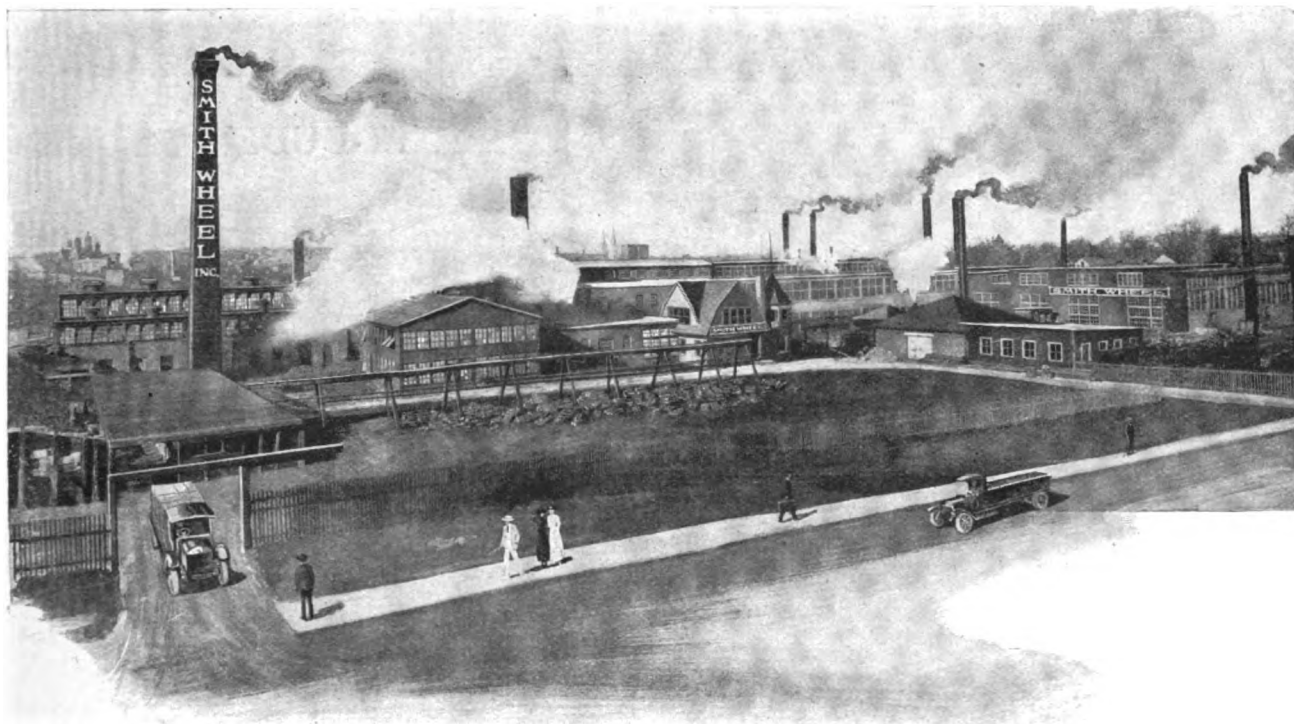

Home of the Smith Wheel



Tire Mileage Increased—Gasoline Mileage Increased—Truck Life Increased

Smith Wheels Guaranteed during LIFE OF TRUCK on which originally placed.



Smith Wheels Make Trucks More Saleable

Made for Trucks of any size and to fit any axle.



We will prosecute any manufacturer of a wheel of hollow spoke design, or of a type having a felloe with internal braces, for infringement of our Patent Rights.

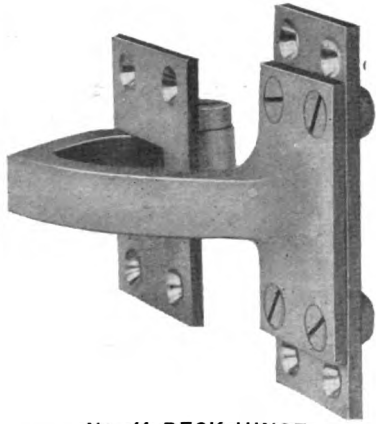

No. 44 DECK-HINGE
For Roadsters and Closed Bodies

Please note the extra body plate. Also the dowel which centers the machine screws, facilitating assembly of hinge to the body.

Another evidence of our system of improvements and suggestions on hardware articles.

We will manufacture high class hardware at less cost to you and give you prompt service.

Our No. 39 Concealed Hinge should be used on your touring bodies.



SEAMLESS TUBING STEEL—BRASS—COPPER

**Send Us Your Specifications
for Rush Requirements**

MURCOTT-DUDEN CO., Inc.

253 Broadway

New York



steel stampings

especially for

COMMERCIAL TRUCKS

The Pressed Steel Co. of N. Y.
141 Broadway

The Laidlaw Company

Inc.

New York City

.....

**Automobile
Fabrics**

.....

**A Fabric for
Every Purpose
For Closed, Open or
Convertible Bodies**

will successfully requirements

s with correct proportions for use in
ufacture of large sheet iron and steel
The large diameter shafts and well-
des allow quantity production that's
..

Double-Crank Presses

for the economical production of vapor
ought iron ranges, agricultural implements,
stampings, steel car parts, ceilings, sidings,
s, window frames and sashes, metal furniture
goods.

over 150 sizes, there is one adapted to your
irements. Write today for descriptive matter.

about presses for any and every requirement

W. BLISS CO

Adams St., Brooklyn, N. Y.

Chicago Office: Peoples Gas Building.
Detroit Office: Dime Bank Building.
Cleveland Office: Union Bank Building.

BRONZE

YOUR CONVENIENCE
VALERS

. D. x 4½ O. D. by ⅛ in.; 12 in. long.

.; 12 in. long.

ULA ESTABLISHED SOME YEARS
OMOBILE AND MACHINEY CON-
MENDED AS THE BEST GENERAL

city who can ship these sizes at once

MPANY, BUFFALO

when you write

Keratol LEATHER SKINS

For the car where leather has always been used



PRICE
Within Reason
QUALITY
Maintained

W^m L. BARRELL Co. **8 THOMAS ST.
NEW YORK**

High Grade Forgings

for CARRIAGE, WAGON, AUTO-MOBILE and SPECIAL WORK

ECCLES BALL-BEARING COUPLINGS are the BEST on the MARKET for DURABILITY and EASE OF ADJUSTMENT

LEATHER BUSHINGS ARE FAST-ENED IN THE SOCKET WHERE THEY BELONG

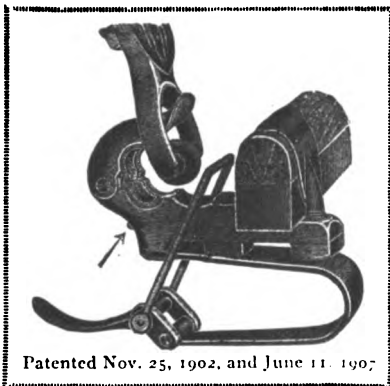

Patented Nov. 25, 1902, and June 11, 1907

SPECIAL FEATURE—THE SPRING IS PIVOTED AT THE FRONT TO ALLOW EASY ADJUSTMENT

Please bear in mind that we make a **FULL LINE** of Carriage and Wagon Forgings, also many of those for Auto and Special Work.

Send for our new Catalogs showing our Regular and Special Forgings.

QUALITY GUARANTEED. SERVICE—THE BEST

Richard Eccles Co.
AUBURN, NEW YORK

RAYNTITE
GUARANTEED

Top Materials

For Making Auto and Carriage Tops, Jiffy Curtains, Envelopes, Accessory Coverings and Storm Aprons

We are now making our RAYNTITE Top materials in two varieties—No. 1 surfaced with FABRIKOID, and No. 2 having the well known FAIRFIELD rubber coating.

For lightness of weight, maximum service and absolute protection from wind and weather, RAYNTITE Top Materials meet the most exacting demands.

Makers of tops and covering for automobile and carriage accessories should write for samples of RAYNTITE and request particulars of our co-operative advertising plans.

DuPont Fabrikoid Co.
Wilmington, Del. Toronto, Ont.

MERITAS LEATHER CLOTH

The Leaders Use the Leading Leather Substitute

MERITAS LEATHER CLOTH is extremely popular with manufacturers of carriages and automobiles because it is the best looking and best wearing leather substitute they have yet discovered.

We purposely make it so good that your customers will comment on the excellent finish, the perfect grain, the colors and the quality.

Every weight, grain, finish and color needed for upholstering and trimming purposes can be had in MERITAS LEATHER CLOTH.

We operate five of the largest plants in the world devoted to goods of this character.

Write for samples to suit your requirements.

Look for the trademark—stamped on the back of every piece

The Standard Oil Cloth Company

INCORPORATED

320 Broadway

New York



1913

1914

1915

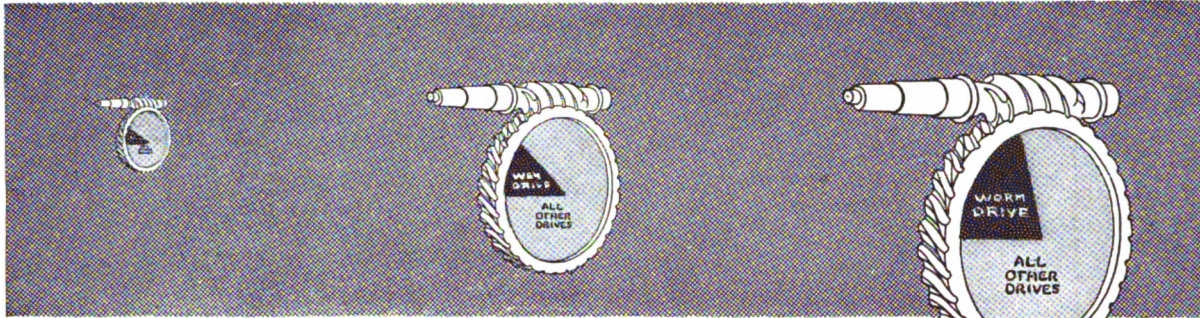

Worm Gear Continues to Increase

FOR 1917 almost a 50% increase in the use of worm gear has been registered, according to the accepted statistics as compiled from manufacturers' reports. This brings the percentage of worm gear models for 1917 up to 61½%, with five other methods of drive dividing the balance. It should be noted that this is a percentage of models produced—rather than trucks actually produced—the only fair way to estimate, as the other method, that of actual number of trucks produced, will show an even larger percentage in favor of worm gear.

SHELDON

Chain drive has fallen from 79% in 1913 to 69% in 1914, 59% in 1915, 33% in 1916 to 20% in 1917. The internal gear rose from 1% in 1913 to a little over 12% in 1916, but this year it drops off to less than 10%.

In this same length of time the worm gear has risen steadily from 1% in 1913 to 61½% in the present year.

In other words the marked superiority of the worm and gear as a type of final drive is so thoroughly recognized that nothing can stop its progress and dominancy.

THE SHELDON AXLE AND SPRING COMPANY

Licensed under the Kardo patents

Makers of Springs and Axles for More Than 50 Years

WILKES-BARRE

PENNSYLVANIA

Chicago: 122 S. Michigan Blvd.

Detroit: 1215 Woodward Avenue

San Francisco: 444 Market Street

1916

1917

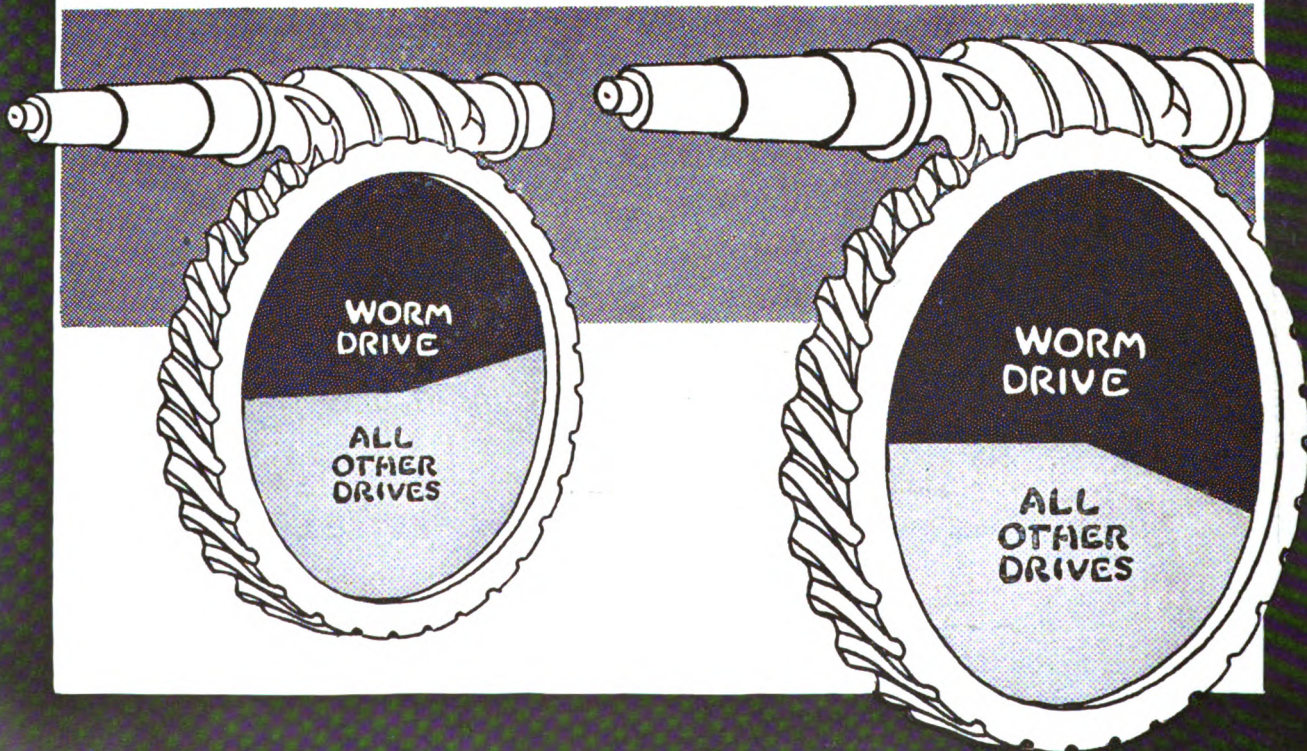

Please mention "The Hub" when you write

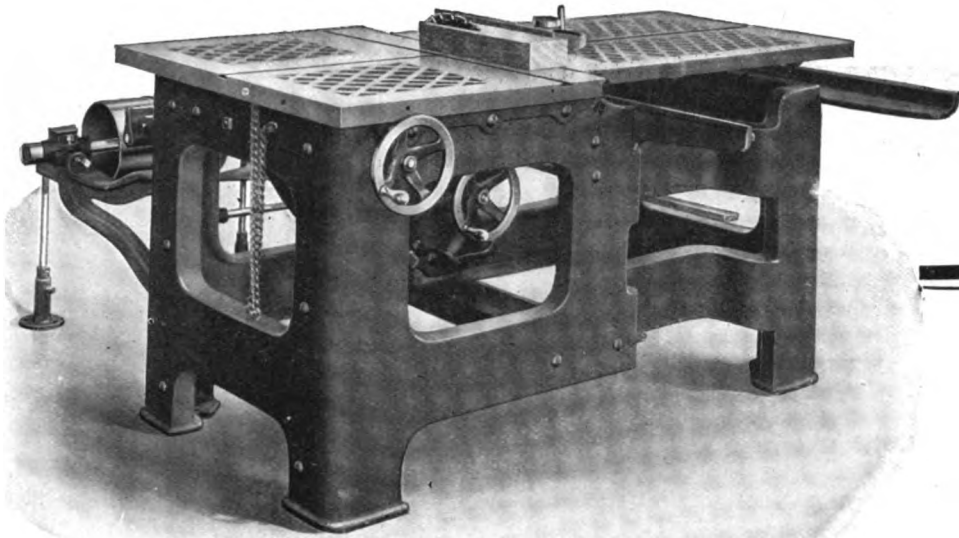

PETTINGELL

Extra Large Bevel and Mitre Saw Table

Heavy work requires a heavy machine. We have built this new machine *massive* and *heavy* and *rigid* to withstand the strain of modern Mill work. It *does* it—does even more—combines all the best ideas of our small Bevel and Mitre Saw with many new improvements, and practical features found *only on this machine*.

Frame work and entire construction are built to eliminate warping or twisting of tables or parts. This permits you to do *perfect duplicate work*. You can saw any bevel, mitre, angle or two angles *at once* and the work will be *accurate* to a dot. It saves time and labor, too.

Saw Can Be Raised or Lowered at Any Angle Up to 45 Degrees Without Stopping the Machine

The work is always level, it cannot bear down on either saws or gauges. Left-hand table can be quickly moved and adjusted as work requires, and the right-hand table can be easily moved to allow Dado heads in place of saw. The table runs very easily, being provided with special rolls and tracks.

It's the best Bevel and Mitre Saw Table in the world—installed in the largest and best factories in Detroit and middle west.

Sold on a guarantee of satisfaction.

A trial is all we ask—the machines do the rest.

Over 400 factories are now using our machines.

We will help you plan and install complete machinery equipment for any kind, style, quantity or output of work you need.

PETTINGELL MACHINE CO.

AMESBURY, MASSACHUSETTS

Drop-Forging Progress Reflects

Crystallized Thought Specialized Study Vitalized Achievement

Its "standard bearers" anticipated exacting requirements and measured their product in terms of quality alone. Time and experience have confirmed their judgment. Only in rare cases now can weaker substitutes be used in place of

"SUPERIOR DROP-FORGINGS" of "Grand Prize" calibre

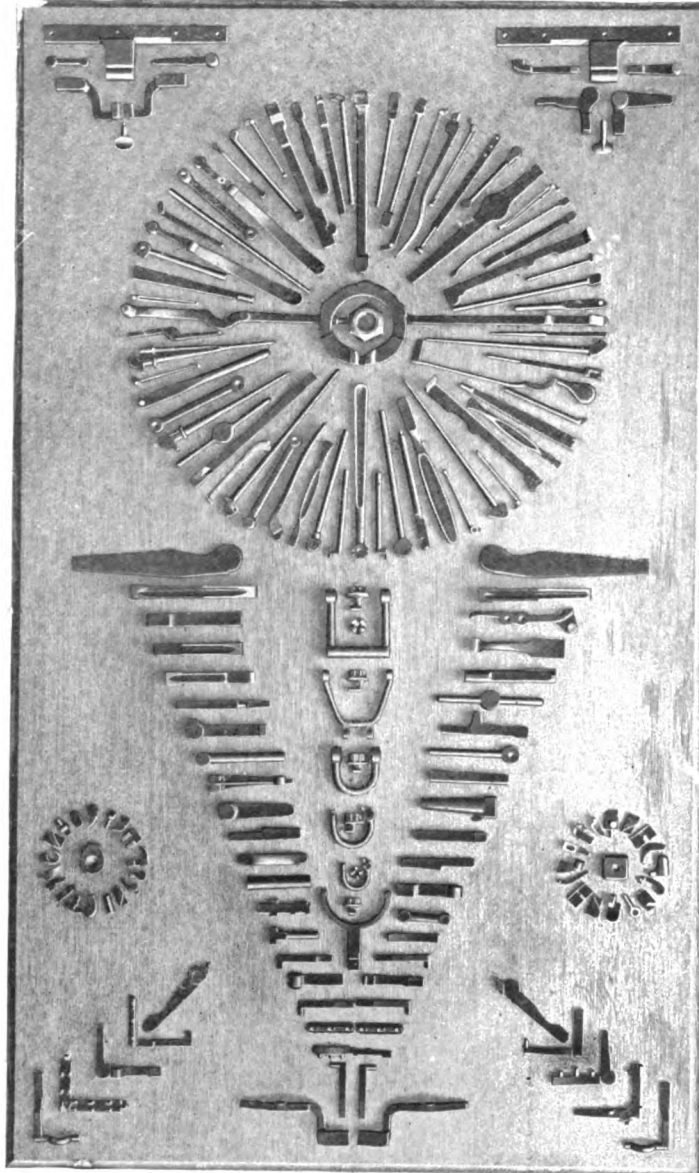

If you want early delivery of dependable Drop-Forged parts for General Machinery, Fire Arms, Sewing Machines, Computing Machines, Knitting Machines, Talking Machines, Electric Motors and Instruments and other delicate mechanisms, send us your specifications.

We specialize in the careful forging and the proper heat-treating of all alloy materials. We possess the necessary facilities and experience in chemical and physical laboratories to develop the maximum in strength and durability with the minimum of size, weight and form.



Please mention "The Hub" when you write

The Hub

Vol. LVIII

NEW YORK, FEBRUARY, 1917

No. 11

Published Monthly by

THE TRADE NEWS PUBLISHING CO. OF N. Y.

PAUL MORSE RICHARDS, *President* G. A. TANNER, *Secretary and Treasurer*
EDISON BUILDING, COR. ELM AND DUANE STS., NEW YORK

THE HUB, a monthly authoritative journal on all subjects pertaining to the vehicle industry from its engineering and construction viewpoints. It publishes information of live interest to manufacturers of motor vehicles, trailers, carriages, wagons, the accessory trades, repair shops and garages.

Subscription price for the United States, Mexico, Cuba, Porto Rico, Guam, the Philippines, and the Hawaiian Islands, \$2.00; Canada, \$2.50; payable strictly in advance. Single copies, 25 cents. Remittances at risk of subscriber, unless by registered letter, or by draft, check, express or post-office order, payable to the order of THE TRADE NEWS PUBLISHING CO.

For advertising rates apply to the publishers. Advertisements must be acceptable to publishers. Copy for new advertisements must be received by the 25th of the preceding month. All communications must be accompanied by the full name and address of writer.

Entered in the New York Post Office as Second-class Matter

Country Gorged With Money

The year starts out with money much the cheapest commodity or form of capital in sight, and if the business community attempts to use these abundant supplies the effect will be to lift wages and the prices of all materials still higher. Already complaints are coming from manufacturers that profits are being curtailed by rising costs, and some people who were perfectly sure a year ago that the country could not have too much gold are now not so sure upon that point. The circle of rising wages and prices narrows as it moves upward, because everybody's income and purchasing power does not increase in the same proportion, and prudent men hesitate to make capital investments on an inflated basis. The statements of country banks show that they have more deposits than they have use for in their own localities. Their reserves are more than twice the legal requirements, and notwithstanding the transfers to the reserve banks during the past year they have more now remaining with their old reserve agents than they ever had with them before.

"There never was a clearer case of a country gorged with money," says the National City Bank Bulletin. The situation is about the same in the Scandinavian countries, but there it is on a comparatively small scale, more easily comprehended, and the importation of gold has been either prohibited or penalized. Persons who have credits abroad are told not to bring gold home, but to either bring commodities which will relieve the stress of high prices, or invest their capital abroad. When every available man and machine is already at work, what more can be done with money? It becomes a stimulus to inflation instead of an aid to industry.

Business has been so good during the past year that a great many producers have accumulated large profits and

are more independent of borrowing facilities than heretofore. They are conservative about dividends, and intend to keep themselves forehanded. At present they are needing more liquid capital than ever before to handle current business on account of the high prices, but as the crest of the industrial boom passes and prices begin to subside, it will appear that a great surplus of money exists in this country.

Importance of the Crops

Great importance will attach to the crops of the coming season. If they are fortunately abundant, the costs of living, now oppressively high, will be reduced, and the entire industrial situation correspondingly relieved. It is assumed as a matter of course that the farmers, being fully as much interested as anybody in large crops, will exert themselves to the uttermost, and that the rest hangs upon the favor of Providence, but when so much depends upon a good outcome it is not out of place to suggest that every public and private agency which can give aid to the farmer should feel an obligation to do so. It is particularly desirable that every locality so far as practicable make itself independent in such food supplies as it can produce. It is usually the case that a one-crop region can grow a moderate variety of foodstuffs with labor that would otherwise count for but little, and if more attention was given to making each section self-supporting in this respect, the net results the country over would be very important.

There never was greater encouragement to the farmers to do their utmost for the production of a large yield. The country will be swept practically bare of all grain before another crop is harvested. The accumulations of wheat from the big crops of 1914 and 1915 will all be gone, and present prospects are that old wheat will sell up to \$2 per bushel before July. Cattle have been sacrificed freely rather than feed corn worth nearly \$1 per bushel. Live hogs sold in January on the Montreal market above \$14 per hundredweight, and in the principal markets of this country at \$11.50 to \$11.90. The stocks of cotton will be low and whether war or peace is to rule next year, a good crop of that staple will be wanted. The farmers of the United States have a great opportunity before them this year; the situation is such that they can hardly fail of good prices for every product.

Foreign Trade Totals

The foreign trade of the United States for the fiscal year which ended June 30, reached a total of \$6,525,000,000, which was \$2,108,025,000 greater than it was during the preceding year.

Description of Fashion Plates

Large Enclosed Drive Simplex

There is illustrated here a large enclosed drive with double belt molding but without center molding. The moldings, upper portions of the mudguards, upper body panels, chassis and wheels are of a dark shade of gray, oil finish. The lower body panels—the major portion of the body—are of a light shade of gray, also in oil finish. The top is covered with gray leather to match the painting. The striping is silver. Spare tires are carried, one in each front fender, and a trunk rack is at the rear end. Inside, the owner's compartment is of the skeleton type, with roof framing and other body work above the belt exposed. This is all painted and rubbed to match the interior gray trimming. The rubber-lined carpet matches the upholstery, and there are two foot cushions with adjusting straps, mahogany ladies' case embodying an eight-day watch and toilet articles, nickel robe rail, two extra seats facing forward folding in the floor and against the partition; speaking tube, ash tray on each arm rest and cigar lighter. The toilet case is mounted on the partition between the extra seats. There is a dome light, of course, ventilators in the roof, and window regulators on the two rear doors and broad lace lifters for the partition and quarter glasses concealed in pockets. The front seat is trimmed in long grain dull finish gray leather with the usual asbestos-lined carpet to match, with leather section at foot pedals. Under the seats are two mahogany tool drawers with locks, and storage space as well. The jack and handle and gasoline tank wrench are carried in special holders under the cowl.

Holbrook Seven-Passenger Limousine

The illustration is of a Holbrook seven-passenger limousine body mounted on a Simplex (Crane model) chassis. A distinguishing feature is the removable extension roof. This lifts off after merely releasing four catches on the windshield and partition, and the effect is that of a very smart town car. Storm curtain on a roller is concealed in the front of the partition at the roof and this may be pulled out and buttoned on the windshield, when the extension is not used. Side curtains also button on.

The body, frame and wheels are gray, with black fenders, fillers, moldings and upper panels. The chassis and bonnet are striped with black. The finish is dull and is known as "satin finish." The spare tires are carried at the rear and cowl ventilators are on each side.

The partition has one wide single glass operated by a mechanical regulator. On the partition hangs a fabric-covered robe strap. The door windows have mechanical regulators, also, while the quarter glasses have lifters of the same material as the upholstery. There are two dome lights, one in the forward center of the roof and one in the extreme rear, both operated by push button switch in the tonneau or from the driver's seat. An inlaid mahogany toilet case with eight-day watch contains the usual articles trimmed in gray leather. This is on the right side, together with the electric telephone transmitter, the handle of which disappears inside the upholstery and the face fits flush in a pocket. The case of the transmitter is in gray pearl with mahogany color trimming. The cord is automatically wound up by a hidden device as the telephone is replaced. On the left side is a mahogany smoking set with electric cigar lighter also attached to a self-winding disappearing cord. The finish moldings are mahogany.

The windows have gray silk curtains with silk cord guides, mounted on automatic rollers.

An extra seat riding sideways folds very close against the left half of the partition. On the right side a portion of partition slides upward and another seat is brought to view. This is slid backward and unfolded into upright position. This has comfortable arm rests and the passenger faces forward. Normally, this seat is entirely concealed in its compartment under the right half of the chauffeur's seat. There are fabric patch pockets on each door with broad elastic bands in them to hold them close to the door. A fabric flap drops over the pockets. A pillow cushion and a loose foot cushion complete the interior equipment. The upholstery is in gray and the rubber-lined carpet matches exactly.

The driver's seat has two cushions of long grain dull finish black leather. The floor is covered with gray corrugated lin-rubber. The loud-speaking earpiece of the telephone projects from the back of the seat at its center.

Seven-Passenger Touring Landauette

A seven-passenger touring landauette is here illustrated, mounted on a Simplex chassis, Crane model. This body was especially designed and built by Brewster to the customer's specifications. It is painted in two shades of gray, dull finish, with gray canvas top. The cushions and leather work in the front compartment are gray. The interior is gray cloth. The two folding seats face forward. The top folds close, the windows disappear in the doors and the rear ones are slid out and stored in special slides under the rear seat. The window lights in the sides and in the partition may be lowered and stored, as mentioned, leaving the pillars in place; or, the pillars themselves can be folded and the car transformed into a touring type with long straight lines. Electric telephone, cigar lighter, both with automatic winding cords, toilet set, foot cushions and robe straps are fitted. The spare tires are carried in the front fenders and a trunk rack is at the rear.

Touring Landauette

A smart-looking touring landauette body is that built by Stone, mounted on a Simplex chassis (Crane model) for N. E. Schwarz, of Chicago. This car is often used for touring and combines speed, reliability and comfort to a remarkable degree. Dull gray paint is used for the major portion of the body and wheels. The fenders, chassis, moldings and leather top are black. The spare tires are carried one in each front fender in covers to match the body color. The radiator and front springs are protected by leather splash apron. A trunk rack is mounted in the rear. Driver's storm top and side curtains button on the windshield and partition.

The top and the pillars fold up and the windows disappear, transforming it into a completely open car. One spare seat with nickel arm rests folds against the partition behind a hinged cloth-covered robe rail, while another smaller seat folds into the floor. The toilet case with eight-day clock and usual articles is finished in black. The carpet is rubber lined, and matches the upholstery. Two two-bulb lights are placed in the rear portion of the top, operated by a switch on the right arm rest, or by the driver from the instrument board. All windows have mechanical regulators. Foot and pillow cushions are among the comforts. The driver's seat is in gray leather, dull finish, with asbestos-lined carpet to match, having a leather section at the foot pedals. The telephone ear piece has been placed under the cowl, which has a mechanical

ventilator. A spot-light has been put on the right hand side of the windshield. There is a locked tool drawer under the driver's seat. Part of the storage space under this seat has been arranged with an opening into the rear compartment to hold miscellaneous articles.

Special Town Landulette

The illustration is that of a special town landulette body by Locke, mounted on a Simplex Crane model chassis. The top completely folds transforming the car into a touring vehicle. The color combination is gray, dull finish, for the body proper, fenders and chassis, with black leather top and moldings, wire wheels, windshield and headlights.

The interior is trimmed in blue corduroy. A carpet to match covers the floor. This is laid over a rubber mat to be used in inclement weather. Both smoking set and toilet case are provided, finished in mahogany with their articles, including nail file, memo. pad, card case, eight-day watch, mirror and pin cushion, in blue leather. Naturally, the silk window curtains are blue in tone. There are two rather small round windows in the rear of the top. Two elongated dome lights are placed in the rear at the top, operated by push button switch in tonneau and at the instrument board. Opening the door automatically lights the dome lights and step lights. There are pockets at the side of the seat. Spare seats, facing rearward, fold up flush with the surface of the partition. Foot cushions with adjusting straps are provided. The windows in the doors and partition are operated by mechanical regulators. When the doors are opened, concealed step lights under the body light the running board.

The driving compartment is finished with long grain black leather. The doors have drop leather pockets. A mechanically-operated ventilator provides cool air to the compartment. The mat is asbestos lined and has a leather section about the pedals. The loud-speaking horn of the electric telephone system is placed under the cowl.

Wire wheels are fitted as special equipment and the spares are carried in the front fenders, locked in place. A trunk rack is available at the rear.

Simplex Seven-Passenger Touring Car

An example of a Simplex seven-passenger touring car, Healey body, is that illustrated. This is noticeable by reason of the long, straight lines, beveled top edge and unusually wide doors.

The color is light gray for the body, with dark gray chassis, wheels and mudguards striped with light gray; oil finish. The trimming throughout is long grain black leather. The trimming is finished off with nickel molding instead of the ordinary leather lace. The one-man cape top is covered with drab Burbank and has the usual side curtains and envelope for the top when down.

The carpet is mixed gray and black woolen. There is an extra rubber mat for bad weather. The carpet is carried up to the top line of the side of the body on the back of the front seat and up on each side to the rear seat frame line. The upper part of the sides is leather, with pockets in the doors. Extra clothing is carried on a robe strap on the back of the front seat. The extra seats fold against the driving seats when not in use, and are of an unusual size and give extraordinary comfort for spare seats. An automatic electric cigar lighter on the right side is concealed in the leather. A step light under the rear door illuminates the running board, automatically controlled by the opening and closing of the door. A

switch on the instrument board cuts off the current in the day time.

The front seat has a division with a compartment for carrying small articles. The front compartment has the usual woolen carpet with asbestos lining and leather reinforcement at the pedals. The cowl has a mechanically-operated ventilator in the top. Storage space is provided under the front seat. The two spare tires are carried to the rear.

Sweeping Changes Necessary in Engine Design

Prof. Walter T. Fishleigh, associate professor of automobile engineering at the University of Michigan, in a paper presented at the winter meeting of the S. A. E. in New York City, predicted that sweeping changes are necessary in the design of gasoline engines and if improvements are not gained in this way the type of engine used must be changed altogether.

In his paper Prof. Fishleigh gave the results of his exhaustive tests into the efficiency of the gasoline engine. He said that his tests showed that only 10 cents worth of power is actually developed from \$1 worth of gasoline in the modern engines at the flywheel and delivered to the transmission box.

Speaking of these tests, he said: "The more we study characteristics of the present type of engine, and the more we inquire into the reason for its manufacturing status quo, the more we are convinced that sweeping improvements in design must come, or the type be changed altogether."

The remaining 90 cents worth of fuel, he said, was developed into power that was dissipated in the form of heat losses through the exhaust, in cooling water and air and in friction.

Philadelphia Auto Show

About 100,000 persons visited the 16th annual exhibition of motor cars in Philadelphia, breaking all records for that city.

The display was held in the largest single story building under one roof in the Quaker city, the Commercial Museums building. Capacity crowds were the rule every day of the week, from January 12 to 20.

In magnitude and importance the Philadelphia show approaches the New York and Chicago exhibitions. There were 117 exhibitors, 66 of which displayed cars in one form or another and 51 showed accessories and equipment. Approximately 280 cars were on exhibition, there being about an equal number of closed and touring models. Roadsters totaled about 60, and there were more than 30 stripped chassis shown.

As regards the cars shown, the Philadelphia exhibition might be called a replica of the New York show, in that the majority of models shown in Grand Central Palace were also displayed in the Commercial Museums building.

Studebaker Offices Removed to South Bend

The executive offices of the Studebaker Corporation, Detroit, have been removed to South Bend, Ind., where the large Studebaker wagon business is concentrated, and where a large number of Studebaker parts are made. The change was made in the interest of centralization of control.

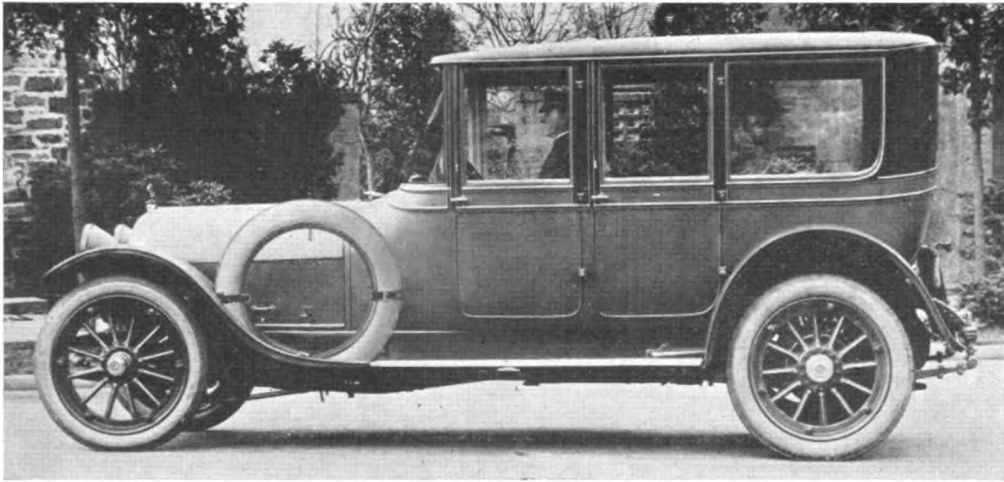

LARGE ENCLOSED DRIVE
 Built by Simplex Automobile Co., New York City

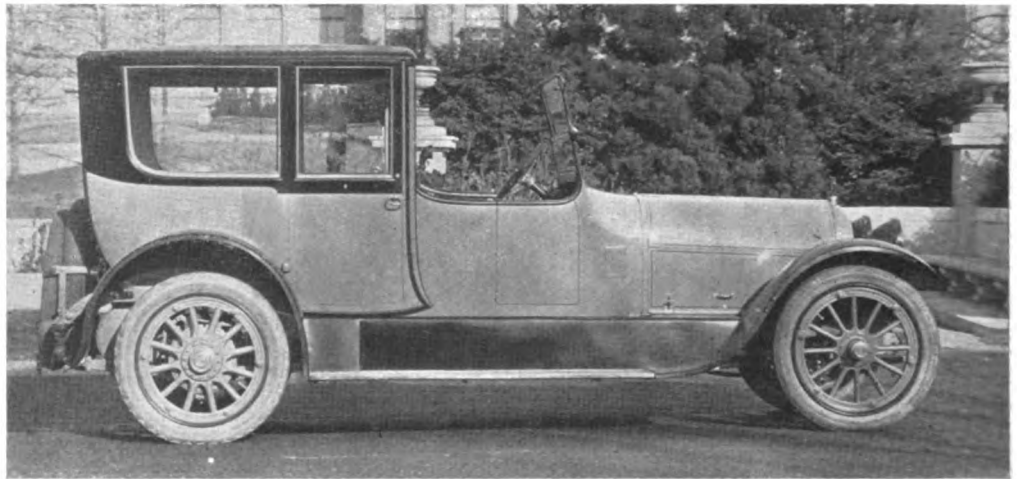

HOLBROOK SEVEN-PASSENGER LIMOUSINE
 Modified on Simplex Crane Model Chassis

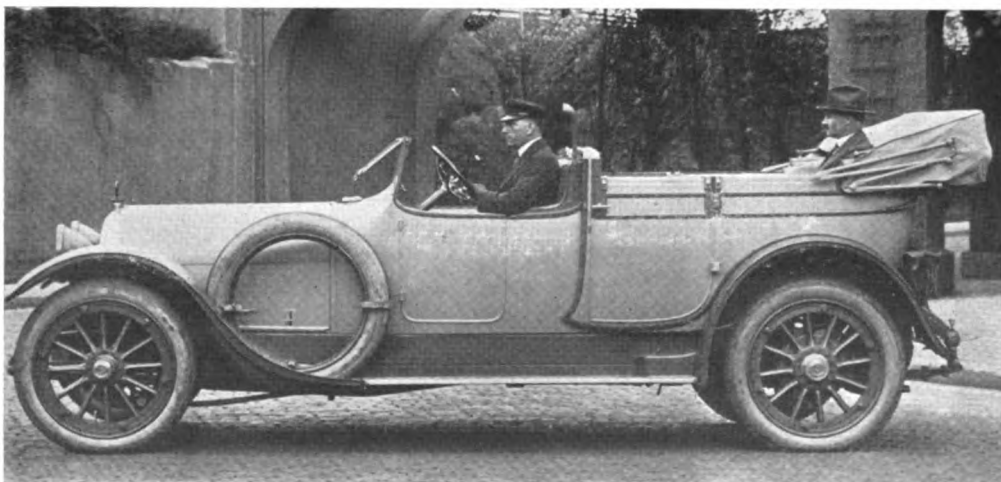

SEVEN-PASSENGER TOURING LANDAULETTE
 Brewster Body on Simplex Chassis



TOURING LANDAULETTE
Stone Body on Simplex Crane Model Chassis

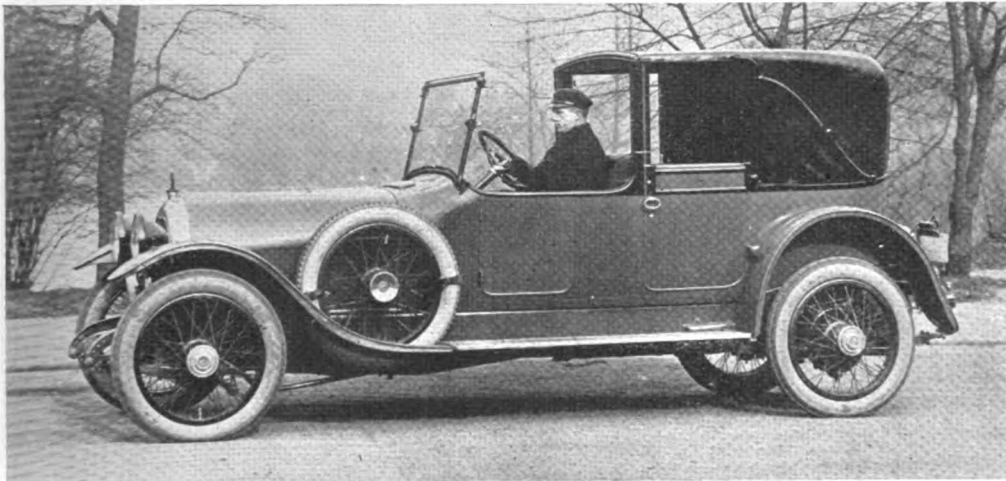

SPECIAL TOWN LANDAULETTE
Locke Body on Simplex Crane Model Chassis

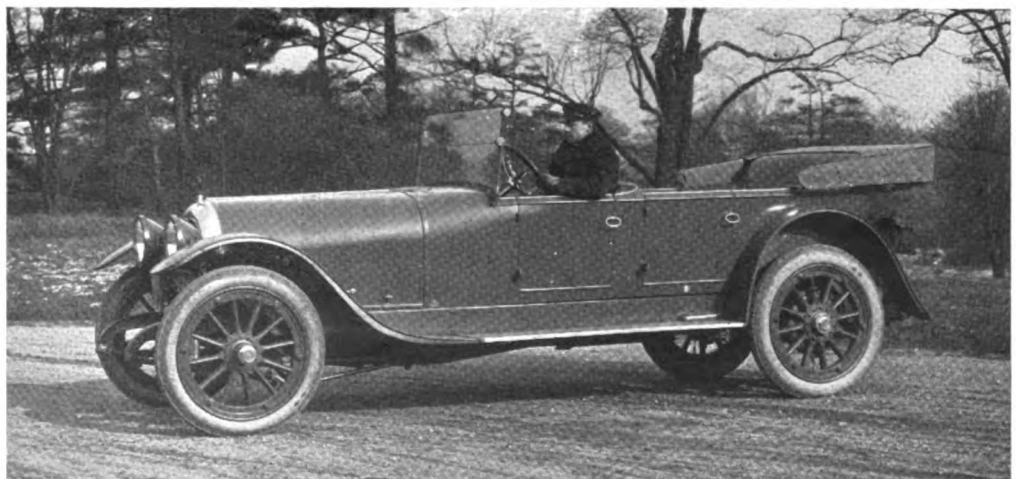

SIMPLEX SEVEN-PASSENGER TOURING CAR
Body by Healey

Vehicle and Implement Woods

The average dealer in buggies, wagons and other vehicles may not be aware that there are no less than 49 specific varieties of wood being used in the vehicle industry. In the United States alone there are approximately 800 million feet of lumber used annually in the vehicle industry.

Oak and hickory constitute the main woods of the vehicle industry. These two woods furnish more than half of the total and there is more hickory used than oak. In fact, hickory alone furnishes practically one-third of the total wood used in the vehicle industry. This is because it not only enters for stakes, body work, shafts and rims, but is very extensively used for spokes.

Even though hickory and oak constitute the main woods used, there is a lengthy list of woods you would imagine are never used. Some of these woods are black walnut, redwood, horn bean, hackberry, buckeye, cherry and eucalyptus. In addition to native woods, mahogany enters quite extensively into the vehicle industry of America, nearly half a million feet of it being used annually, while some other imported woods include Circassian walnut and rosewood, padouk, china tree, Spanish cedar and doncella. Some of these woods cost over \$200 per thousand feet. These imported woods are usually to be found only in the making up of trim for fancy automobiles where they enter as veneer. Mahogany is used to some extent solid, but many fancy woods are used in veneer in the trim of automobiles.

The least expensive of all the list of woods used in vehicle industry is hackberry, while the most expensive is Circassian walnut, which runs up to nearly \$300 per 1,000 feet. Hickory comes nearer the average price of all woods but it is a fairly expensive wood in some areas. The thing that brings the average hickory down is its comparative cheapness near the source of supply. An odd thing in this connection is that both poplar and ash are listed as costing more than hickory and the same is true of cottonwood and birch. In fact, there are several native woods listed as costing more than hickory.

Considering Implement Woods

If we add to the vehicle requirements the woods used for the production of farm implements, we find that in the United States the composite requirements of vehicles and implements require, roughly, 1,060 million feet of material. This makes it the fourth largest wood consuming industry in America. To give some idea of the large variety of woods used, the following list gives the species most commonly used for the purpose indicated:

Box boards—yellow poplar, cottonwood, red gum, tupelo; box cleats—yellow poplar, cottonwood, rock elm; box beds—long leaf pine, birch oak; bed cleats—oak, rock elm; axles—hickory, maple; bolsters—oak, hickory; sand boards—oak, hickory; poles—oak; brake bars—oak, rock elm; reaches—oak; standards—oak, rock elm, hickory; hounds—oak, rock elm; spokes—oak; rims and felloes—oak, osage orange; hubs—white, red and willow oak, black and yellow birch; double-trees—hickory, rock elm, oak; singletrees—hickory, rock elm; neckyokes—hickory, rock elm.

The hardwoods used in this industry are first air dried for about two years and then kiln dried. This entails considerable loss, due to seasoning rough dimensions, planks and boards of the woods most generally used. In hickory, oak and pine, for instance, the percentage lost in

seasoning is from 10 to 12 per cent, the average waste being about 10 per cent. This is unavoidable waste and can only be reduced to a very small extent through the medium of humidity dry kilns which dry out the boards in a "wet" atmosphere.

There is also considerable loss of material in the manufacture of carriages, wagons, wheels, poles, shafts and gears. In manufacturing from rough stock, the following articles, a general average waste of from 15 to 20 per cent is met with: Axles, bent work, bolsters, carriage bodies, gears, hubs, poles, rims, seats, shafts, shaft crossbars, spokes, single and doubletrees, wagon bodies.

To this average waste of 15 to 20 per cent must be added the losses in seasoning, bringing the total losses in the industry to at least 25 per cent of the total timber requirements. Such, briefly explained, is a feature in the waste problem relating to the use of wood in the farm implement and vehicle industry.

Process of Making Laminated Frames

A lumber yard in connection with a modern manufacturing plant for constructing and assembling the mechanisms of motor cars would impress the "man on the street" as out of place. But this apparent inconsistency is a logical development at the plant of the Franklin Automobile Co., Syracuse, N. Y., for the reason that the chassis frames of Franklin cars are made of white ash rather than steel, because of the ability of the wood to absorb vibration.

The buying of the white ash for such use is a real problem. Close, straight grain, even texture, freedom from knots or other imperfections and extreme toughness are the qualities necessary and these are only found in second-growth white ash native to northern Pennsylvania, New York and some of the New England states. The fact that New York state alone uses about 17,000,000 feet a year, while growing only about 8,000,000, shows the relation of demand to supply. At present the company is using about 2,000,000 feet a year.

Only the very best parts of the best stock go into these frames and as a result probably not over 30 per cent of a log will cut up into suitable grades. Seasoning brings out imperfections which do not show in freshly cut lumber and thus only about one-quarter of a white ash log will eventually find its way into chassis frames.

The process of transforming the lumber into wood frames is long and expensive. The boards are air dried for one year and then kiln dried for about two weeks before going to the wood-working department to be made up into frames. Here they are planed and cut to proper size. Each side of a frame is made up of three pieces, glued together under pressure and held by 25 screws. Weather strips protect exposed edges from the elements. This laminated frame possesses enormous strength; in fact, strength tests show that while this frame is 50 per cent lighter than the ordinary pressed steel frame, it is 65 per cent stronger under a load. The laminated construction further aids in raising the safety factor, as there is little danger that flaws will occur in the three pieces at the same place.

Detroit's Desperate Fuel Situation

Detroit is suffering from coal famine. All the manufacturing plants are economizing in power as much as possible and a number of companies have made short shut-downs.

Chicago Automobile Show

Four new cars made their appearance at the Chicago Automobile Show which was held in the Coliseum and Armory, January 27 to February 3. These were the Stephens, Hassler, Chicago and Classic—all assembled from standard units of conventional design.

There were a number of cars on exhibition that were not shown in New York, the Glide, Monitor, Maibohm Woods Dual Power and Dixie. While there were a number of the cars shown in New York that were not exhibited in Chicago, the large manufacturers were all represented.

Some of the manufacturers did not carry to Chicago the same cars that they employed in New York, but revealed new exhibits, composed principally of stock products, supplemented by the individualized types so rapidly gaining in favor.

There were 92 car exhibitors compared with 80 last year; and a total of 324 cars and chassis, or 30 more than were exhibited in Chicago last year.

Although Chicago has always been the leader in the display of electrics, the exhibitors numbering many more than seen in New York, this year there were only four shown, Detroit, Milburn, Ohio and Baker R. & L.

A Ford car display, the first in years, attracted a great deal of attention. The new Ford dealer policy makes no restrictions on show exhibitions, so the Erwin Greer Automobile Co., one of the several Chicago agents, placed three cars on exhibition.

The automobile manufacturers did not attend the Chicago show as well as they did New York, leaving Chicago more to the sales and advertising managers and dealers. Two big shows in one month seems to be too much for some makers.

It is claimed that there has been a shortage of closed cars throughout the west. The manufacturer, being concerned most about production, has had eyes only for standard types of open cars.

A developing tendency is that of giving buyers wider color options, but placing a price on the extra work. Overland and Cadillac led in this movement a year ago and since then several others have fallen in line. The Hudson distributor for the Chicago territory has added a paint and finish department and is flooded with work. Other distributors have the work done by contract.

The Salon

At the Salon held in the Elizabethan room of Congress Hotel there were 20 cars and one chassis. Two new cars not exhibited in New York were the Fageol and Disbrow.

The Fageol is the product of the Fageol Motors Co., of Oakland, Cal., and sells for \$9,500 for chassis alone. Body work in connection with chassis is additional, and optional with the purchaser.

The body work of the car on exhibition is the product of Kimball, of Chicago, and is a sumptuous affair. A green-gray touring body, with eider down cushions, plush lined top and body, polished mahogany flooring, glass panel instrument board, and ivory-mounted handles on doors, contributed to an atmosphere of regal splendor. The car has adjustable front seats which slide back and forth to suit the occupants. It is fitted with a Victoria top lined with silk plush. The outside of the top is mohair. The floor coverings are also of silk plush over the mahogany floorboards. The ventilators in the top of the hood are

CHICAGO AUTO SHOW STATISTICS

Exhibits		
	1916	1917
Car manufacturers	80	92
Total number cars and chassis.....	294	324
Stripped chassis	52	50
Four-cylinder	106	101
Six-cylinder	135	164
Eight-cylinder	42	41
Twelve-cylinder	11	18
Total	294	324
Body Types—Open Cars		
Five-passenger	64	75
Six and seven-passenger.....	57	54
Two-passenger	33	21
Three-passenger	23	9
Four-passenger	10	47
Total	187	206
Body Types—Closed Cars		
Coupe	7	14
Sedan	10	26
Demountable top	18	9
Cabriolet	2	0
Limousine	10	12
Landaulet	1	0
Town Car	5	1
Berline	2	1
Total	55	68

striking and tend to relieve the long line of the hood covering the Hall-Scott aviation motor housed within. The sale price of the engine alone is \$5,400. It develops 150 horsepower.

One of the most distinctive features of the car is the sloping radiator, which overhangs the front axle, completely masking it, and presenting a most formidable appearance. It also contributes to cooling efficiency owing to the downward pitch of the air passages. The radiator shell slants backward and upward at practically the same angle as the windshield; the core is likewise slanted. In consequence, the air passages through it slant downward toward the engine, so that incoming air currents impinge directly against the walls of the passages, instead of rushing through them with only surface streamline contact.

The Disbrow car is a product of the shop of Louis Disbrow, Cleveland, O., former driver of racing cars. It is a speed design, shown in a special aluminum body, of which there is very little besides the hood and the racing style seats. The bodies are made individually to suit the size of the buyer. Bicycle-style fenders are employed which turn with the front wheels, thus protecting the driver from mud spray when turning corners. For protection of the side of the car there is a horizontal fin running the length of the frame on each side like an elongated running board. The car is equipped with a four-cylinder Wisconsin engine, 5 1/10 x 5 1/2 in dimensions.

The other cars in the Salon were the Locomobile, Brewster, White, Simplex, Murray, Daniels, Lancia, Marmon and Doble.

German Substitutes for Rubber Bicycle Tires

The scarcity of rubber and the partial commandeering of rubber bicycle tires have caused a number of substitutes to appear on the German market, writes Vice Consul H. E. Carlson, Frankfort on the Main, dated November 18. The substances used are steel wire, leather, wood, prepared canvas, and combinations of these substances.

The first substitute to appear was a tire made of steel wire, about 3/16 in. thick, which was made up into a very close coil, the two ends being welded together so as to give it the proper shape. The wholesale price of this product is now 12 marks (\$2.86), and it is retailed for 18 marks (\$4.28). Besides the fact that the price is high, the steel-coil tire has the additional objection that it cuts into the pavements and rattles considerably when in use. The latter objection might be overcome, it is said, by placing a layer of felt between the rim and the tire, but this would increase the price.

Three Different Types of Wooden Tires

Wooden tires have been used with some success. At least three different types of which wood is the main part are sold. In a few cases the tires are made of a single piece of wood, and retail at 4 to 6 marks (\$0.95 to \$1.43). Sectional wooden tires also have appeared on the market. One of these is made by the Continental Caoutchouc und Gutta Percha Comp., of Hannover. It is composed of 47 parts. These are 12 wooden tire sections of three different kinds, 12 tin plates, 12 screws, 10 connecting pins, and one thumbscrew. The tin plates are used to secure the sections to the rim, which must be of metal; the screws to attach the tin plates to the ends of the sections; the connecting pins to hold the sections together, and the thumbscrew is put through the valve hole in the rim and thus tends to attach the tire more firmly to the rim. The company is selling this tire for 6 marks (\$1.43). In reality the expense is a little more for in order to give satisfactory shock absorbers in the form of steel springs must be attached to the fork of the front wheel. These springs retail at 7.50 marks (\$1.78) and are also to be had through the Continental Co. This brings the total cost for a set of tires up to 19.50 marks (\$4.64).

Leather Covers Outer Surface of Wood

A third wooden tire which is advertised is said not to be meeting with great success on account of the price. This is made of one piece of wood, the outer surface of which is covered with a small strip of leather. Between the under surface of the tire and the rim several steel springs are placed with a view to securing elasticity. In addition to this, large steel springs are attached to the front and back forks. The cost of this outfit, including the two tires and the large springs, is 36 marks (\$8.57).

Several leather-covered and canvas-covered tires also are on the market. These are solid, the outer casings being of leather or prepared canvas, and the inner part consisting of wood and other substances. To make the tire more durable small pieces of steel are often affixed to the outer or wearing surface. The prices for products of this class vary. One fairly good leather-covered tire retails at 48 marks a set (\$11.42); another at 70 marks (\$16.66).

Has Certain Amount of Elasticity

The tire that is said to have the strongest claim to being a real substitute for the rubber article appears on the market under the name of "Lobo." It is made in Chemnitz, Saxony, by the Kunstgummi. G. m. b. H. It is composed

of two parts, corresponding to the former inner and outer tires. The inner part, which is most important, is solid and is covered with cloth made in the shape of a tire. The tube is filled with a preparation resembling rubber. The outer tube is composed of prepared canvas and is said to have very good wearing qualities. The effect is to give the tire a certain amount of elasticity, so that it can be used without springs at either of the forks. The price for a set of these tires is 52 marks (\$12.38). This will doubtless tend to restrict their use.

The most practical tire, from the point of view of both price and service, seems to be the sectional wooden tire.

Australia's Purchases of Motor Vehicles

Statistics of Australia's purchases of foreign motor cars and motorcycles during the first six months of the current year show a very large increase over those for January-June, 1915; in fact, the imports during the first half of 1916 equal the imports for the whole of 1915. The trade of the United States for the half year made the noteworthy gain of 221 per cent in chassis, 267 per cent in motor car bodies, and 303 per cent in cycles. Canada likewise increased its shipments materially, an advance accounted for by the fact that the Canadian Ford Co. supplies Australia. By chief countries of origin the imports for the first six months of the last two years were:

Articles and countries of origin.	First six months—	
	1915	1916
Chassis for motor cars, etc.	\$2,037,837	\$4,177,754
United States	841,740	2,707,754
Belgium	23,963	1,363
Canada	346,865	798,232
France	96,804	111,613
Germany	16,994	1,659
Italy	138,092	243,072
Switzerland	1,552	10,146
United Kingdom	571,819	303,962
Bodies for motor cars, etc.	437,474	1,054,814
United States	229,927	843,355
Canada	78,166	159,066
France	2,482	10,298
Germany	1,800	190
Italy	7,699	10,633
United Kingdom	117,030	30,834
Motorcycles, etc.	300,540	580,729
United States	88,916	358,544
United Kingdom	209,978	222,151

The Commonwealth's imports of "rubber manufactures not elsewhere specified," under which classifications tires fall, reached a value of \$2,558,538 in the first six months of 1916. Of these the United States supplied \$1,793,826 worth, Canada \$164,531, France \$129,055, Italy \$33,204, Japan \$11,120, United Kingdom \$422,266, and all other countries \$4,536 worth.

To Build Sunbeam Engines in U. S.

The Sterling Engine Co., Buffalo, N. Y., has secured the manufacturing rights for the production in America of Sunbeam engines. The company hopes to have an American-made Sunbeam twelve-cylinder aeroplane engine running about September of this year.

Ohio Light Bill Passed by Senate

The Terrill Bill requiring lights on all vehicles, both horse and motor propelled, has passed the state senate at Columbus and is now pending in the House. The bill was drafted by the Ohio State Automobile Association.

Glimpses of Giant Machinery in Nash Factory

Right — Battery of Erie forge hammers. When tuned up they remind one of life in the trenches.

Lower Left — Jeffery fenders are stamped from sheet steel on giant Bliss presses. Dies for these machines are made in Nash shops. After fenders are stamped they are electrically spot-welded, making them rattle-proof, as there are no bolts or rivets to wear loose.

Lower Right — There are 27 of these trip hammers in the Nash shops. All drop forgings that go into Jeffery cars and trucks are made here. Skilled mechanics, through years of experience, become so expert that they can strike a match without crushing the stem, or break the crystal of a watch without injuring the mechanism.

There is one feature about the Nash plant that is toally different from the Detroit factories. The workmen are stationary. Instead of a constant shift from one employer to another, they remain on the payroll for long periods of time. There are 80 names on the Nash payroll that have been there for 12 years or more.

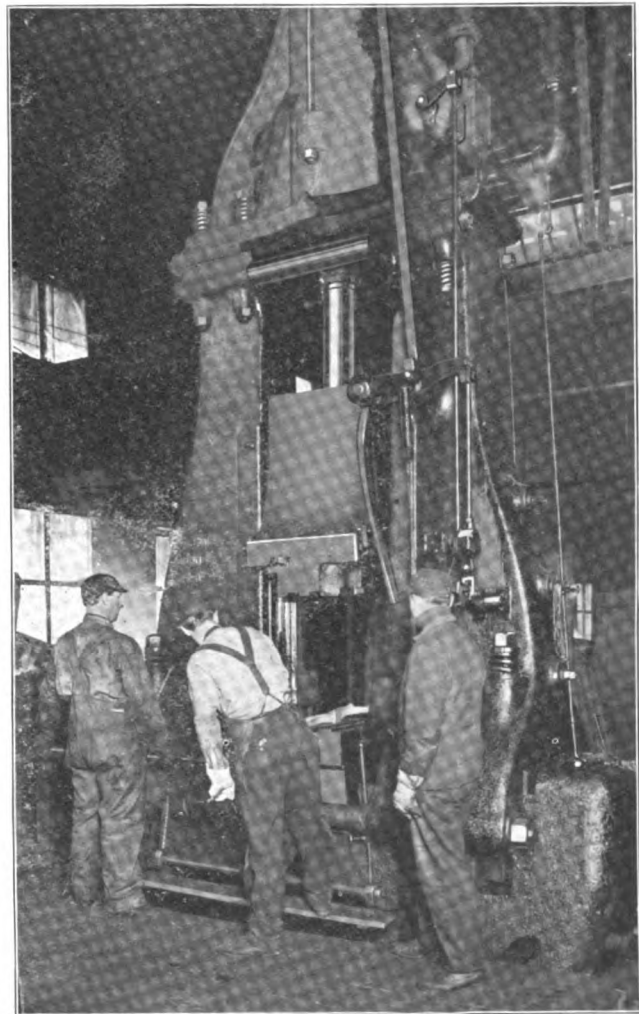
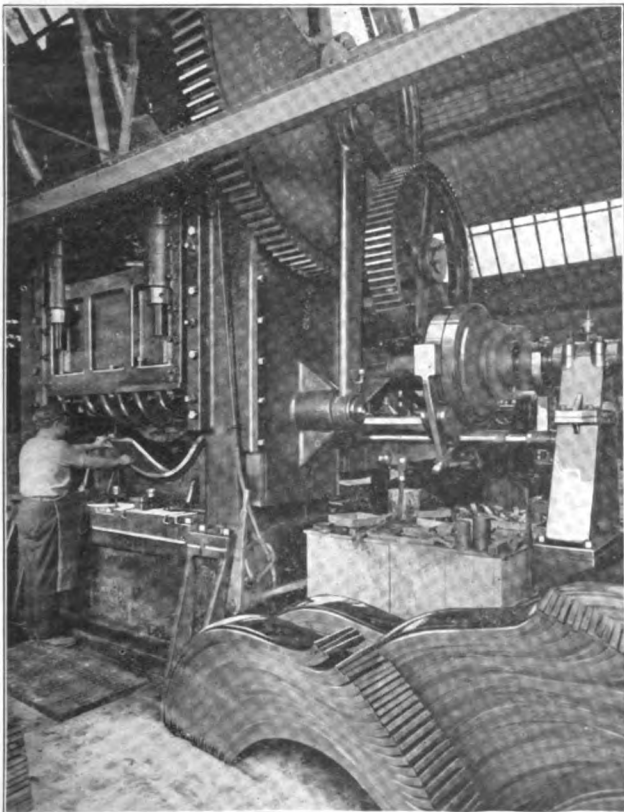
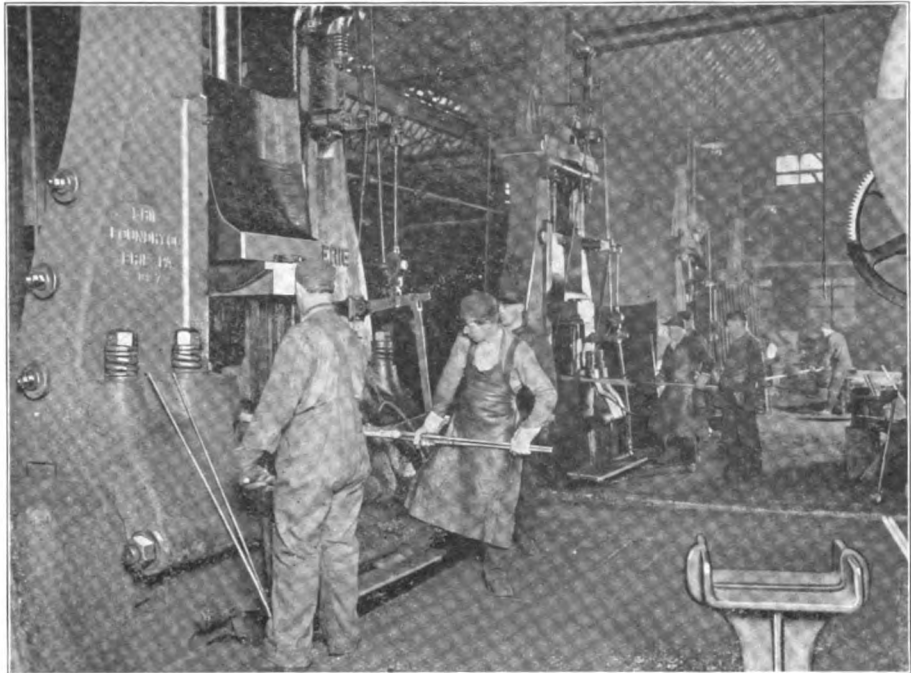

Lumber Industry Conditions Revealed by Forest Service

That unstable and partly speculative forest ownership in the west and south is the cause of frequent over-cutting of the market and waste of forest resources is announced by the Forest Service in a report just off the government press. Too large stocks of timber acquired from the public domain and too much timber speculation mixed with the manufacture of lumber, says the Service, underlie the present instability of the industry.

The Forest Service advocates various forms of open-price co-operation among lumber manufacturers to make the industry more efficient and check wasteful over-production. But it is strongly against changes in the present competitive character of the business through combinations to control output or regulate prices, even though advocated in the name of conservation.

The business of making lumber, says the report, has been loaded down with investments in timberland. The productive branch of the industry has been interlocked too largely with speculations in its raw material; and instead of standing on its own feet as a manufacturing business has tended to be the tail of the dog, made frequently to serve the exigencies of timber speculation. Pressure from an overload of timber is the first cause of the general instability of the industry. It has led to building mills beyond the demand for their products. At least a third of the saws are now idle.

On the other hand social and economic changes in the United States are reducing its proportionate use of lumber. Uses taken over by other structural materials within the last ten years are estimated at one-fifth of the present yearly cut of lumber; and in the same period the per capita consumption of lumber seems to have passed its peak and dropped nearly one-fourth.

Caught with its burden of timberland on the one hand and these changes in the country's use of wood on the other, the lumber industry has been between an upper and nether millstone. The combined result is an ill-adjustment of lumber production to market requirements, with frequent, almost chronic overproduction. Ups and downs have been the rule with most manufacturers in the west and south. Occasional years of high earnings have been followed by usually longer periods of small profits or loss. The latter reached their climax in 1914 and 1915, although 1916 brought somewhat better conditions.

Lumber retailing was studied in all of the middle western states only. In that region the Service found it to be competitive for the most part, although its competition is less rigorous than in the case of lumber manufacturers. The restraints upon trade in lumber distribution, however, in the central states studied, are judged to be local rather than general; and developments in recent years have tended to increase competition.

The rising cost of lumber to consumers, which held generally up to 1907, is attributed by the Forest Service primarily to the exhaustion of the supplies of timber nearest to the bulk of eastern consumers, and the necessity of transporting lumber from greater and greater distances. Railroad freights now take a fifth or more of the consumers' price, retailers about the same amount, and manufacturers, on the average, little more than one-half. The high cost of lumber is thus due in large part to local timber shortage, resulting from the rapid using up of for-

ests without provision for their renewal. Other causes, according to the Service, lie in the greater demands for specialized service made upon the retailer by the purchasing public, in higher labor costs, and in the decreasing purchasing power of money. Since 1897, however, the effects of overproduction have been felt, and the prices of common structural woods have made no sustained increase.

The report lays special emphasis upon the fact that such waste in the use of our natural forest wealth as is now taking place will tell inevitably in the future cost of lumber, paper, and other products manufactured from timber, as it has told already in many "cut out" states. Furthermore, under present conditions, little is being done to restock the forest lands logged for their virgin timber. The total use of wood in the United States exceeds by a good deal the aggregate growth of its forests; and unless the enormous areas of cutover land, to which millions of acres are added every year, are put to growing new forests, the danger of a nation-wide shortage of timber and high prices for all wood products will become acute.

The experts in the Forest Service believe that a more stable kind of forest ownership, divorced from manufacture to a larger degree than now, must come about before the ills of the lumber business can be cured permanently. This kind of ownership must not only carry the present stocks of merchantable timber until the productive industry needs them, but also provides for regrowth on cutover lands. The extension of public forest ownership, both state and national, should in the judgment of the Service, have a large part in this accomplishment.

A national mistake, the report goes on to say, was made in such rapid and wholesale passing of title to timberlands in the public domain, beyond all immediate needs for local and industrial development. Private ownership, hard pressed to carry these staggering quantities of timber during the long periods which must necessarily elapse before they can be converted into lumber, is now sacrificing them in part by wasteful use because of its own financial exigencies. The report urges that this situation be faced frankly and the obvious remedy applied, that of taking part of the western timberlands back.

Finally, the Forest Service disagrees radically with the idea now mooted in many quarters that forest conservation should be sought through permitting industrial combinations for the regulation of lumber production or control of lumber prices. The Service believes, in fact, that such measures as joint control of lumber output by agreement would be ineffective in holding back the pressure to cut timber and in overcoming the other weaknesses which cause overproduction. Betterment in the industry must come largely through strengthening individual operators or owners, and particularly through a more stable ownership of forest lands.

The Forest Service advocates such forms of co-operation as trade associations and selling agencies, safeguarded by public supervision and regulation. But changes in the competitive status of the industry, like joint control of production or price, can, in the view of the Service, come about only with an entirely different national conception of the country's basic resources. The adjustment of public and private interests in a national policy which seeks the wisest use of forest resources and controls the industries which exploit them may then become possible, including the principle of regulating output.

Suggestions for Ford Truck Bodies

The body designs shown in the illustrations are for the Ford chassis, and measure 8 ft. back of the driver's seat. Fig. 1 is a body design for grain and feed, or it can be used for carrying brick. The floor of the body measures 8 ft. back of the driver's seat and is 5 ft. 6 in. wide. At

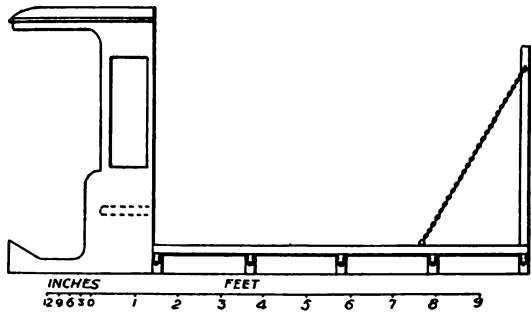

Fig. 1

the rear of the body is a high slat tail gate 4 ft. 6 in. high, to which is attached a chain, which gives a support to the tail gate when the body is fully loaded. The floor of the body is mounted on five 3 x 5 in. cross bars, which in turn are bolted to the chassis frame.

Fig. 2 represents a department store body, which has a loading space back of the driver's seat of 8 ft. by 4 ft. 2 in., and is 5 ft. 6 in. high. This is a plain side panel

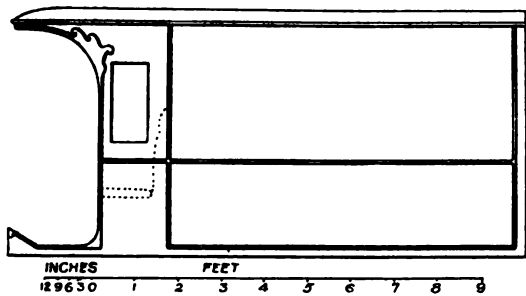

Fig. 2

body, which has a total length from the front of driver's seat of 9 ft. 9 in. At the rear are two hinged doors, which open outward. This body is mounted on the chassis frame, without cross bars.

Fig. 3 is a body design for a brewery body, which is 8 ft. in length back of the driver's seat and is 5 ft. 6 in. wide and 2 ft. 6 in. high, having a flare board at the top,

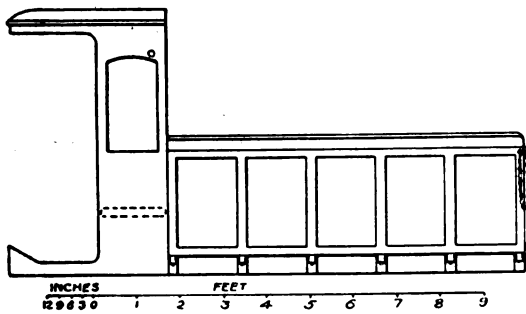

Fig. 3

strap and braced well on the inside. The body is mounted on six 3 x 5 in. cross bars, which are bolted to the chassis frame. There are six uprights on each side, measuring 3 x 3 in., as this is necessary in the construction of a

brewery body on account of the weight carried against the sides.

Fig. 4 is a design for a furniture body, which is 8 ft. back of the driver's seat and 5 ft. 6 in. wide and 5 ft. 6 in. high. This body is only half paneled, having two removable stakes at each side opening. This body is also

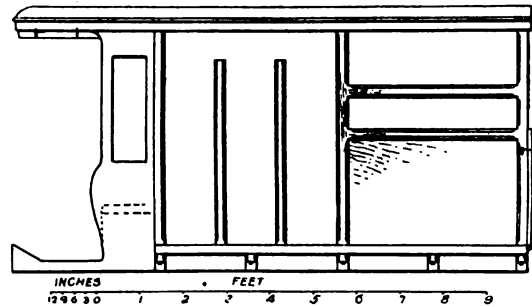

Fig. 4

mounted on five 3 x 5 in. cross bars, which are mounted on to the chassis frame. These cross bars being used to give proper wheel clearance, and is far better than building a wheel house, which would take up the necessary floor space.

Fig. 5 is a body designed for carrying bags of coke, coal and wood. This is a slat side body and is 8 ft. back of the driver's seat and 5 ft. 6 in. in width. The sides are 3 ft. 9 in. high. The slats are made from 2 x 3 in.

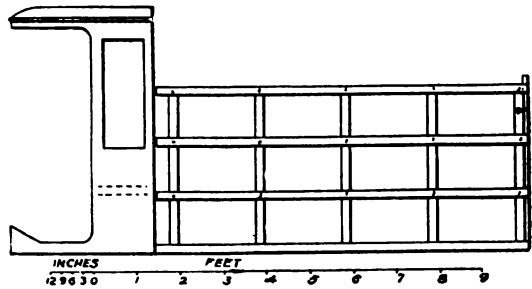

Fig. 5

hard wood. This body can have a wheel house or can be mounted on cross bars, as shown in other designs mentioned. This body can also be used for carrying terra-cotta building material.—Blacksmith and Wheelwright.

Newark Auto Show

The Newark (N. J.) Automobile Show has been transferred from the First Regiment armory to the Palace ball room, Bleacher and Washington streets. The shift was made because the military authorities wanted the armory as a measure of preparedness in case of international complications. There will be no change in date, the show opening Saturday night, February 24, and continuing for a week.

The new show building is conveniently located, being right in the heart of Newark, and near the railroad and trolley terminals. It is particularly adapted for show purposes, with main floor and balcony. All the original exhibitors will continue in the new place, though dealers with large space allotments will be cut somewhat. Trucks and commercial vehicles have been eliminated, but the accessory men are kept in the show.

This Is a Time for Cool Heads and Not Cold Feet

By the Foreign Trade Department of the National Association of Manufacturers

Whatever may be the political result of the severance of diplomatic relations on the part of the United States with the Central Powers, there is no reason for panic, nor even ground for serious apprehension for the immediate future on the part of the American manufacturer with respect to the continuance of the general volume of our export and import trade.

In the interests of the nation at large, as well as in their individual interests, it is in order for manufacturers carefully and calmly to survey the outlook as it pertains to their oversea operations.

For many months submarine activity has been very great on the part of the Central Powers and large numbers of enemy ships have been destroyed. Nevertheless the import trade of the countries most directly affected has notably increased, while the value of their exports has tended to increase rather than decrease.

These statements are illustrated by the following figures, showing our exports to France, Italy and the United Kingdom in 11 months ending November, 1915, and 1916:

Value of American Exports for 11 Months

	1915	1916
To France	\$452,576,134	\$802,132,401
To Italy	247,411,431	265,537,270
To United Kingdom.....	1,072,887,384	1,702,906,305

Our imports from these countries have also shown an increase in this period, despite the increasing menace of the submarine warfare. The following figures illustrate this point:

Value of American Imports for 11 months

	1915	1916
From France	\$67,935,357	\$98,404,909
From Italy	47,105,500	55,445,970
From United Kingdom.....	231,192,517	279,727,143

The apparent failure of this submarine warfare in its object of blockading the ports of the above three countries is shown by comparison of their trade with this country for the month of November last (the latest for which statistics are available) as compared with the same month of 1915. These figures are shown in the following table:

American Exports for the Month of November, 1915, and 1916

	1915	1916
To France	\$49,950,576	\$91,732,089
To Italy	26,160,026	35,584,578
To United Kingdom.....	104,632,785	145,684,875

Pessimists or apprehensive ones may say: "But if this submarine warfare should have the effect, or somewhat near the effect, intended by those who are responsible for its operation, we should apparently stand to lose an immense volume of trade which would seriously react upon the industries of this country."

The answer to this is that assuming even the most that can be expected of the submarine warfare on the part of its sponsors, this, while resulting in cutting off a large proportion of our trade with western Europe, would, at the same time, operate to annihilate a still larger volume of trade on the part of the allied countries with their colonies and neutral nations, necessitating those countries and colonies seeking in American markets sources of sup-

ply for the goods heretofore obtained from the blockaded lands.

Taking into consideration the volume of exports of the United Kingdom alone we find by the figures issued by the Board of Trade for the calendar year 1916 that they amounted in value to \$2,500,000,000, of which about \$300,000,000, or less than one-eighth, came to the United States, leaving over two billions (\$2,100,000,000) of dollars' worth of goods to be supplied to other markets in case British exports should be wholly stopped. Of course, a very large proportion of this quantity went to France and Italy, but to offset this, in part at least, is also the large amount of export trade which Italy and France have done with neutral countries despite the exigencies of the great war, which if stopped would require the neutral nations to seek chiefly in the United States.

Whether or not a state of war develops between the United States and the Central Powers, the area of submarine warfare is not likely to be greatly changed, as naval authorities deem it imperative for those powers to secure their aims that they should concentrate their submarine energies in the waters of the western group of the Entente Powers as limited by the declared boundaries of the blockade war zone. This would leave the waters of the great oceans practically as safe as they are at present. Moreover, the transportation difficulties which have prevailed since the war began might even be somewhat relieved in the waters outside of the war zone, as, should the submarine peril become more dangerous, vessels of neutral nations would more and more seek the safer waters, and thereby afford greater facilities than at present for the transportation of American cargoes to any part of the globe outside of the war zone.

Consequently, a possible curtailment of trade with western Europe by submarine warfare will necessarily operate to open up additional opportunities for business in the regions which cannot be materially affected by submarine operations, and which include the rich markets of all Latin-America, Asia, Australasia and Africa.

As a precedent of interest in this connection it is well to keep in mind that notwithstanding the state of war existing between Japan and the Central Powers, the Japanese export trade (outside of munitions) has greatly increased as the war has progressed.

It is to be sincerely hoped that no stronger action will be required on the part of the national administration to maintain our international rights. But whatever may be the outcome and until called to other activities, it is the duty of manufacturers to continue their cultivation of export trade with the same energy and same degree of optimism as has characterized the great majority of them throughout the long years of this war.

Batavia to Take Over Simplex Rubber Co.

The Batavia (N. Y.) Rubber Co., and the Simplex Rubber Co. of America, Ossining, N. Y., will merge, and the latter company will assign all its property, patent rights and agreements to the Batavia company.

The Batavia company has for some time contemplated adding to its production solid rubber tires for trucks and also certain classes of mechanical rubber goods. The Simplex Rubber Co. has been operating since November, 1916, under patent license rights granted by the Simplex Rubber Co., of Willesden, Eng., and has been showing satisfactory results from its operations.

Destructiveness of Truck Overloading

Manufacturers of Vehicles and Parts Endeavor to Establish Responsibility of Owners' Misuse

Overloading, which undoubtedly has been more destructive of motor vehicles than any other cause, and which the industry has thus far not been able to deal with so that the owners and drivers responsible for this misuse of machines must suffer the consequences of their own carelessness or neglect, has been given direct attention by a considerable number of truck and truck unit manufacturers because of the endeavor of Fred L. Martin, sales manager of the auto axle department of the Sheldon Axle and Spring Co. to crystalize opinion as to what had best be done by the different interested enterprises, either individually or collectively, to induce, or perhaps compel, the carrying of freights not exceeding the load ratings of machines.

The Sheldon Axle and Spring Co. manufactures both truck axles and truck springs, and it has, as has other makers of parts, had to deal with demands made upon truck builders using its product by owners who have sought to obtain replacement of units on the ground that these were defective of material or workmanship. The Sheldon Axle and Spring Co. is a legitimate business enterprise of large proportions, and while it is desirous of making every transaction satisfactory to truck buyers so far as this is possible, it does not purpose to assume responsibility beyond what it is legally and morally obligated to assume.

The attitude of the company with reference to unreasonable demands upon it does not differ from that of any other concern, but the belief of Mr. Martin that the subject justified serious consideration by every interest prompted him to send a circular letter to every truck builder and part maker in America of whom his company had record. This letter asked the companies receiving them to make such suggestions as might appear to be a solution of the situation. The companies from which worth while replies were received numbered 84, 59 of them being manufacturers of trucks, while the remaining 25 included builders of fire apparatus, tractors, trailers and such parts as axles, springs and bearings.

Industry's Unanimous Attitude

There was not, of course, anything like unity of opinion as to what might be done to relieve the companies from what was seemingly regarded as imposition, but there was practically unanimous belief that the industry was justified in seeking means to protect itself against the unreasonable demands of those who sought to have the builders of machines assume responsibility for use that they could not control. The companies from whom replies were received do not represent the entire industry, to be sure, but they are entirely reputable concerns who have found the demands of truck owners as a whole so unreasonable that they were and are willing to join in whatever will be an equitable plan to insure to the purchasers of trucks all they can logically expect and at the same time safeguard themselves.

There were many probable causes assigned by the writers of the letters for the very general overloading, and some of them frankly stated that they believed that nothing that could be done would prevent or rather prohibit owners from doing with their property whatever they cared to do, and several were inclined to believe that the sale of machines without guarantee, so that the owners would have to be responsible for their use, was the only practical manner of freeing themselves from assumed obligation to renew parts damaged or destroyed by the buyers or those representing them.

Manufacturers Disregard Ratings

Every letter of the series is decidedly interesting and worthy of careful analysis, but obviously only the general trend of opinion can be stated, because of the great space

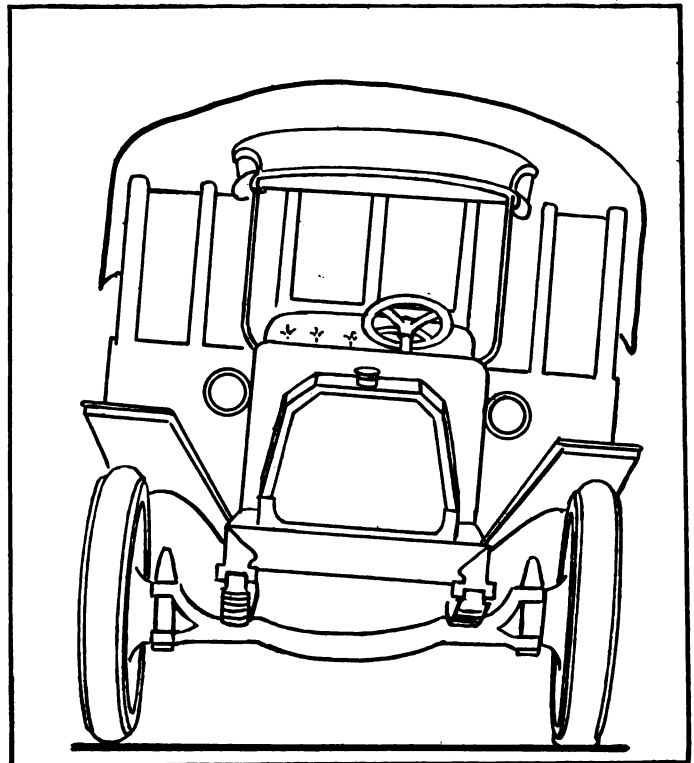

Sketch showing exaggerated result of careless loading that causes chassis distortion, spring sag and unequal wear of the front tires

that would be necessary to give each in detail. Practically every writer agreed that power trucks are more or less overloaded, and that rated capacities are often very largely exceeded. Why owners sanctioned misuse of their property is primarily due in part to the claims made by some manufacturers—that their trucks are so designed and constructed that they can be freighted with from 25 to 50 per cent more than the rating without more than normal deterioration from service.

Such claims are believed to justify overloading, and the

owners accept the stated capacities as those with which the machines can be ordinarily worked, and at times exceed them. Another cause is the statements made by salesmen who, in their anxiety to meet competition and make sales, unhesitatingly inform their prospects that the vehicles can be worked with heavy overloads without damage, and with such assurances the owners authorize their drivers to carry loads that are excessive. Of course, the

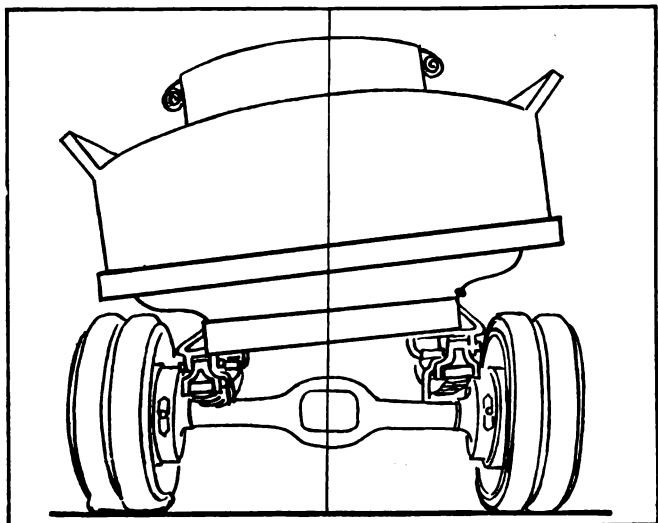

How rear tires, axles and springs are subjected to overloading when the load capacity of the machine may not be exceeded. This sketch is exaggerated to emphasize the result.

trucks are sold as being rated for definite loading, and the owners know this, and they are also aware of the very general provision of the sales contracts that nullifies guarantees in the event greater weights are carried, but there is seemingly belief that contract conditions can be ignored by them and the verbal assurances of the salesman or dealer substituted whenever there is reason to avoid the clause referring to overloading.

Responsibility of Tire Manufacturers

While overloading in the final analysis comes back to the owners of machines, some of the letter writers were of the opinion that tire companies might be more or less responsible through the sale of over-size tires to owners who found that normal equipment would not endure under excess freights, and believed that if the tires endured there was no reason to expect mechanical deterioration. This was a phase that apparently could only be dealt with save with co-operation of the tire manufacturers.

One fact to which attention was directed is that the United States government specifies that machines purchased by it for practically all services shall have 50 per cent overload capacity, which is regarded as encouraging owners and users to carry greater loads than the machines are rated for normally. This means that trucks bought by the government are purchased with the assurance that they have larger capacities than the ratings and can consistently carry heavy freights. To offset this is the high character of the maintenance required by the government, which is entirely different than that afforded by the average owner.

Another suggestion was that the tire companies sell larger tires, because some trucks are overrated by the manufacturers and more or less undertired, so that the machines would have at least tire equipment that would be adequate, and in this manner somewhat better protected than they now are. This appeared, however, to anticipate discrimination between the owners who buy oversized tires to carry heavy loads and those who buy oversized tires to obtain greater mileage and really economize tire expense.

Automatic Load Regulation Proposed

One parts manufacturer proposed that the trucks might be equipped with some form of automatic device that would prevent overloading, and another was of the opinion that truck users should have scale equipment so that all doubtful loads could be determined, and still another proposition was that plates specifying the load capacities of rear axles be placed on every machine in view of the drivers.

Many of the writers confessed that they could not make suggestions that appeared to them to be practical, though they were in accord with any proposition that promised to bring about any desirable change, and they were anxious to have opportunity for studying the replies of others that they could have better information for basing determination. A majority of those engaging in the correspondence were emphatically of the belief that a campaign of education directed toward the owners, which could be conducted through the columns of the trade press and by advertising, would be productive of good results, but, of course, nothing like a definite plan was proposed.

One reply made the proposal that in inaugurating such an educational campaign a high grade writer be employed to prepare a series of articles that would have the approval of the industry as a whole and which could be submitted to different publications as representing the views of the manufacturers of trucks and truck units, and which could be published in connection with special advertising that would deal particularly with overloading. Another suggestion relative to such a campaign was that the different concerns interested organize an association that would, among other things, direct systematically such advertising

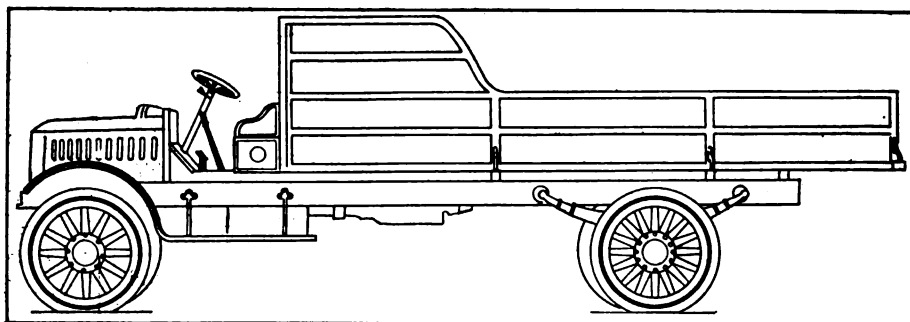

When a truck is loaded to capacity and the freight is well placed the load on the tires and the entire construction should be to the ratios fixed by the designer.

and publicity as the conditions met with appeared to justify.

One will understand that practically every concern was willing to unite in a movement that would promise to bring about a change for the better, and no conditions were specified, so that one may assume that were such a campaign begun it would be well supported by the different companies. Another aspect that is worthy of consid-

eration is the fact that a sufficient fund could be raised, with a comparatively small sum from each interest, which could be expended for such purposes as appeared to the contributors would be most beneficial.

Included among the proposals was that the different concerns of the industry hold a conference at which the subject could be considered to any length desired and a practical determination reached as to what course had

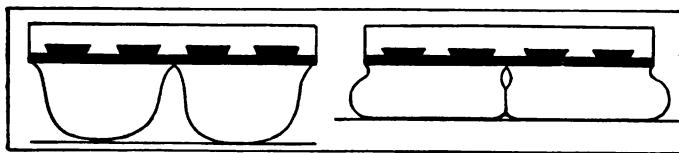

At left is a cross section of a dual tire not carrying weight; at right a section of a tire when overloaded. Sketch exaggerated

best be followed. Having received the different letters, copies of them were prepared and were sent to those engaging in the correspondence with the expectation that, after examination, suggestions might be made that would lead to a definite action. While the Sheldon Axle and Spring Co. is not committed to assuming the initiative in the proposed campaign, there is reason to believe that it would be willing to undertake its part and that it would be followed by others.

Attitude of the N. A. C. C.

In connection with this subject the National Automobile Chamber of Commerce, through the commercial vehicle committee, has sought to formulate a plan that will discourage overloading. It has recommended to its members the placing of load rating plates on the vehicles they build. It has specified body weights for different chassis, and provided that when the machines are loaded in excess of the capacities the guarantees shall be nullified. The standard warranty of the organization is for 90 days, and applies to defective material and workmanship.

The National Automobile Chamber of Commerce does not by any means include all of the concerns in the motor truck industry. Probably not more than one-third are represented in its membership. Those that are affiliated are, as a rule, large and progressive enterprises that have had quite as much, if not more, experience with the destructiveness of overloading than those unaffiliated.

Without assuming to reflect the views of the National Automobile Chamber of Commerce, there is one aspect that cannot be lost sight of by the industry, and that is the necessity of taking such action as will fully protect the manufacturers against imposition. The number of

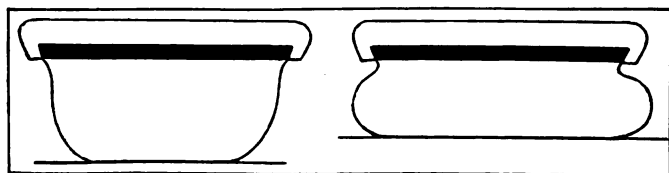

At left a cross section of a single tire as designed to carry a load; at right cross section of a single tire distorted by overload

trucks in service will be very largely increased the present year, and there is every reason to expect extremely rapid replacement of other forms of transportation equipment.

The larger concerns will undoubtedly suffer in largest measure from this cause, and probably to whatever degree they will endure, because there is evidently a considerable proportion of vehicle buyers who believe that they can compel manufacturers to assume responsibility for misuse

of machines through fear of loss of reputation by statements of implied liability. This is not a legitimate attitude for any man to take, yet dissatisfied customers can destroy reputations much faster than it can be established, because only one side is given a hearing and there can be no defense for the manufacturer other than a policy that is well defined and absolutely maintained.

Those Who Pay the "Freight"

There is still another phase, and that is that those who use their vehicles reasonably and do not overload them must pay for the negligence and indifference of others, for without question the demands of those who are destructive of their property must be reflected in the market prices of the machines. One can be certain, says Motor Truck, that no business can be continued without a reasonable profit, and this must be provided for in the selling valuations. This aspect must receive careful consideration. Practically all trucks and delivery wagons are bought for economical reasons, and whatever will enter into investment or operating expense are determining factors with buyers. Purchasers, with rare exceptions, measure the value by the dollar with extreme care, which is diametrically opposed to their policy when a pleasure car is being considered.

Just to what extent overloading affects manufacturers is not known, but from the statements made there is no

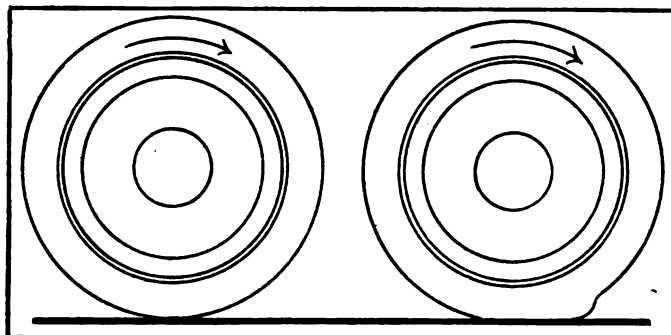

At left a tire not distorted by weight; at right a tire showing in exaggerated form the wave of rubber that is caused by loading and which moves around the circumference as the tire is turned by the wheel

question of its importance to them, and probably some are more affected than others. When one understands that close to 90 per cent of the industry purchases and uses constructional units produced by specialists, and that claims made by owners eventually revert to the part makers, the reason for their interest in the subject is apparent.

There is no question whatever that overloading demands the attention of the industry, its engineers, designers, sales representatives, the owners, drivers and those engaged in repairing and maintaining machines. But so far as the owners and drivers are concerned they must be educated to the false economy of carrying loads that are in excess of the ratings, for while there are liberal factors of safety provided in all trucks, exceeding the load limits established cannot be otherwise than destructive, and generally in proportion to the overloads.

American Automobiles in Java

Consul B. S. Rairden reports from Batavia, Dutch East Indies, that of the 759 automobiles imported into Java for the first six months of 1916. 668 cars came from the United States, 53 from Italy, and 32 from the Netherlands.

Establish System of Bonus Payments

J. H. Williams & Co., 61 Richards street, Brooklyn, N. Y., has established a system of bonus payments which will be put into effect for the company's entire organization in Brooklyn and Buffalo, in accordance with the following provisions: Bonuses will be based on 13 weeks' pay at a time, and paid on the next following payday to all men in the company's employ at the time. The normal rate of bonus based on the rate of pay will be 10 per cent on salaries less than \$1,250 per year; 7½ per cent on salaries less than \$2,000 and equal to \$1,250; 5 per cent on salaries of \$2,000 or more. The bonuses for hourly pay will be 10 per cent on less than 45 cents hourly rate; 7½ per cent on hourly rates equal to 45 cents but less than 60 cents; and 5 per cent on hourly rates equal to 60 cents or more. Bonuses for all piecework will be figured at 5 per cent, including overtime.

Hall Lamp Co. Buys Badger Brass

The purchase of the Badger Brass Mfg. Co., Kenosha, Wis., by the C. M. Hall Lamp Co., Detroit, was completed January 20, the price being approximately \$400,000. The business will be carried on from the central offices at Detroit, Mr. Anklam handling both plants as the general manager, and G. A. Mahler working as the manager of the Kenosha factory.

G. A. Yule, president; R. H. Wells, treasurer, and G. C. Koch, vice-president of the Badger company, retired from that concern immediately following its sale.

The name of the Badger Brass Mfg. Co. will be perpetuated by its purchasers. The consolidation makes the Hall company the largest producer of its kind. Business for the next year for both plants, it is estimated will total more than \$2,000,000.

Ford Surplus \$120,000,356

The Ford Motor Co., Detroit, on January 31 filed with the Massachusetts State Commissioner of Corporations a balance sheet as of January 18, showing a surplus of \$120,000,356, which compares with \$111,960,907 on July 31 last, and \$59,137,771 on July 31, 1915. The sheets lists on the assets side \$26,739,261 in real estate, machinery at \$12,445,277, merchandise at \$45,297,639, cash and accounts receivable at \$53,064,700, making a total of \$137,547,038. Liabilities are itemized as capital stock, \$2,000,000; accounts payable \$15,546,682, and surplus \$120,000,356.

At the same time that this balance sheet was issued, confirmation came from Pittsburgh of the report that the company is to establish a factory in Ireland. The American Bridge Co., Pittsburgh, has sold to the Ford company a total of 20,000 tons of steel to be used in the new plant in Cork. The Ford company also has ordered about 20,000 tons of sheets, bars, tubes, wire and other products.

Goodrich Employs Jobless Soldiers

Akron soldiers who enlisted and went to the border have been offered positions by the B. F. Goodrich Co., Akron, O., in case they find their places in business houses filled on their return home. This offer is in pursuance of the policy of the company to encourage national military training, and the operating committee of the company states that the factory can take care of all the soldiers from Akron who are able to qualify physically. The helping spirit of the company is further shown by the fact that

when military training camps were announced early last year, Goodrich employes were allowed leave of absence for four weeks' stay on full pay. When the troops were called to the border, Goodrich men who were enlisted were told that those with dependents would be allowed two-thirds of their regular monthly pay while absent, and unmarried men would be given one-half pay, and their positions kept open for them.

National Chamber Elects Officers

R. Goodwyn Rhett, of Charleston, S. C., was reelected president of the Chamber of Commerce of the United States, following the fifth annual meeting of that organization held in Washington recently.

Other officers of the National Chamber have been reelected as follows: Harry A. Wheeler, of Chicago; John H. Fahey, of Boston, and A. B. Farquhar, of York, Pa., honorary vice-presidents. Samuel McRoberts, of New York City, vice-president; and Joseph H. Defrees, of Chicago, vice-president and also chairman of the executive committee.

John Joy Edson, of Washington, has been reelected treasurer. The newly elected officers are: Hon. Charles Nagel, of St. Louis, honorary vice-president, and Willis Booth, of Los Angeles, vice-president.

U. of M. to Have Summer Motor School

There will be a short course in automobile engineering given by the University of Michigan, Ann Arbor, Mich., next summer, and the University is calling the attention of automobile companies and their workers to the course, which offers exceptional facilities for short training in the various branches of automobile work. The University for some time has had an automobile engineering course in its regular curriculum, and has found it to be popular, so much so, in fact, that a need for the summer course was shown. There will be offered one general course in gasoline automobiles, covering the fundamental principles of operation and design and their application in current practice. In addition, there will be a course in design and theory, one in chassis theory and design, and one on testing.

Packard Makes Promotions

C. F. Tollzier has been made production manager of the Packard Motor Car Co., and will retain his present work as purchasing agent and manager of the service division. D. F. Roberts has been made the factory manager. Mr. Roberts was formerly the superintendent of the factory. J. E. Leher has been appointed as manager of the motor carriage division in charge of chassis and body manufacture. R. N. Brown has been made superintendent of the chassis division, and L. E. Jolls has been promoted to be mechanical superintendent.

Eastern Woods in the West

It is a peculiar situation that the wagon makers in the state of Washington are transporting oak from the eastern states for vehicle stock. The oak stock used costs \$104.77 per thousand feet delivered at the factory. A little native Pacific coast oak is used, but this oak is not found suitable for the most exacting places in vehicle manufacture.

Springing—Dealing Particularly With the Problem of the Suspension of Light Cars

It is often urged against reducing the weight of a car that, by so doing, its ease of riding is lessened—in other words that weight is a desirable factor in the interests of comfort. A contributor to *Light Car*, an English publication, in this simple study of the first principles of suspension, shows among other things that this is a fallacy.

“There is little doubt,” says the writer, “that after the war many makers will try to reduce the weight of their complete cars, as the idea that comfort and security can

only be obtained by massive construction is now being finally abandoned, but there seems to exist some misgiving that lighter light cars will mean comparatively worse sprung cars. This idea is, as a matter of fact, not without justification,

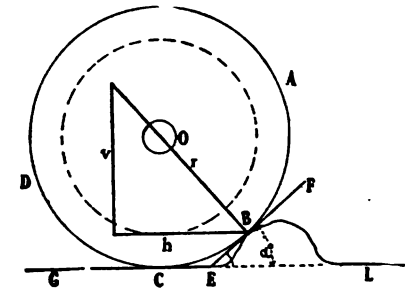

Explanatory diagram of the forces involved in a wheel striking an obstacle

but the reason lies rather with the human weakness of owners than with the manufacturers, or because of any inherent difficulty in the design of springing for lighter cars.

Of Major Importance

“It will be generally conceded that the springing of a car is one of the most important items, since on it depends very largely the comfort of the passengers, and not only that, but also in some measure, the well being of the whole mechanism of the car. Nevertheless, it is a matter little understood, and if motorists had a better grasp of the subject they would be less likely to make demands on the capabilities of their cars, in providing for which the makers have to sacrifice to some extent the comfort of the car when in use in a legitimate manner. For this reason we will start by describing simply the principles governing the suspension of a car.

“Consider the case of a car running along the road and meeting a small rise, or bump, which is represented, diagrammatically, and in an exaggerated manner, in the figure.

Overcoming an Obstacle

“ABCD represents the periphery of a wheel, which is meeting an obstruction, the point of contact being at B; EF is a tangent to the circle ABCD at B, and meets the ground line GL at E; BO is drawn perpendicularly to EF through B, and through O, the center of the wheel. Obviously, BO is the line along which the blow acts, and any length of it, chosen on some suitable scale, will represent the blow, both in force and direction. Let r be such a length. Now r may be resolved into two components, in the usual manner, vertical and horizontal, these being, in the figure, represented by v and h respectively; which means, in practice, that the wheel of a car on striking a bump is not only lifted, but also experiences a backward thrust, and, since on most cars there is little or no provision for absorbing this thrust, other than the ‘give’ of the tires, it explains certain phenomena occurring

on some cars on a particular kind of road surface, but this concerns the designer rather than the owner, and so need not be gone further into here.

“The magnitude of r in a given case will be related to three things—(a) the value of a, the angle formed by EF and GL. With small wheels a will be greater than with larger ones; (b) the speed of the car, and (c) the weight of the car.

Elementary Principles

“We will now examine the principles on which a spring works. If a spiral spring is suspended and a load applied, the extension will be proportional to the load, provided that the spring is not overloaded. Let us suppose that we have a spring balance of the usual direct reading type, and that the travel is limited to two inches, with a scale of that length divided up into tenths of an inch. With a ten pound spring—that is, one which extends one inch per ten pounds of load—we shall be able to weigh up to 20 pounds, and each scale division will indicate one pound. Now let us suppose that we wish to increase the range to 100 pounds. To do this, a spring of 50 pounds will be necessary, and now each scale division will read five pounds, so that we have made the instrument much coarser; in other words, we have obtained range at the expense of delicacy. The same principle holds good for car springs, and the case of the spring balance is quite analogous to that of a car, so that if a car is required to carry loads varying over a large range it must have much coarser, or harder, springs than if the load only varies a little.

“We can now apply these principles in answering the question: Can a very light car be as comfortably sprung as a heavy one?

“First of all, how do they compare with one another with regard to values of r? Under (a) the only thing affecting a will be the size of the wheels, since both cars run on the same roads, and there is no reason why the wheels should differ much in size. (b)

There is no need to assume a difference in speeds. (c) The weights of the cars, of course, vary, and since (a) and (b) are the same in both cases, r will vary as the weight. This is only common sense, for the greater the momentum the greater the shock, naturally. But, since the shock varies directly as the weight, it will have no more effect on one car than on the other.

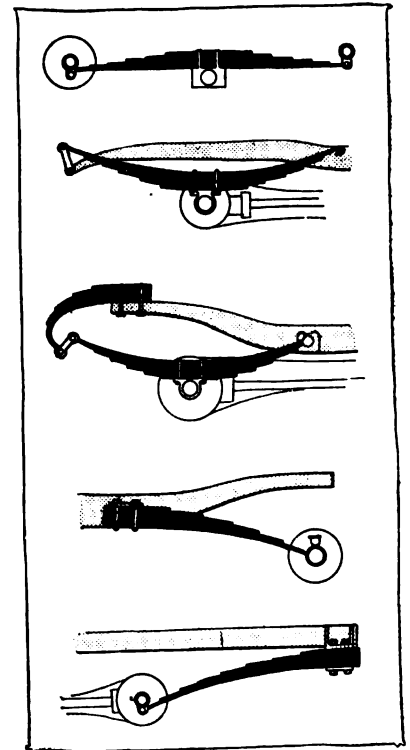

Diagrams illustrating the various common forms of rear suspension. Reading downward, these show respectively cantilever, semi or half elliptic, three-quarter elliptic, quarter elliptic, and reversed quarter elliptic. Two light cars employing the last are the Baby Peugeot and the Bugatti

Weight Is No Advantage

"So far neither car shows an advantage, and we now come to the question of range of load. If both cars carry their proper number of passengers, the dead load will not vary, practically speaking, and the load on the springs, when running, will vary more in the case of the heavy car than in the case of the lighter one. Were the cars equal in size, the advantage would lie, therefore, with the lighter; but in practice the lighter would be also smaller, and this fact probably about takes away its advantage.

"To digress for a moment. If any reader still slings to the superstition that mere weight makes for easy riding, he is recommended to travel a short distance in a Baby Peugeot and then in a traction engine—quite a short journey in the latter will suffice.

"Resuming: it was stated that a light car will be just as easy to spring well as a heavy one, if each only has to carry the correct number of passengers, and this is the real point. Everyone has seen a two-seated light car going 'all out,' with five up; also pictures of similar cars with eight or ten fully grown people piled on them. If these pictures were only meant to show the imbecility of the owners of the cars, all would be well; but, in fact, there are people who expect a car to stand this sort of treatment, and so designers have to make provision for it, which means that the springs cannot be made nearly so suitable for their real purpose as they might be if owners would resist the temptation to overload their cars.

Where the Difference Lies

"For some reason, perhaps out of regard for their dignity or comfort, owners of large cars do not appear to overload them so badly, but even if they sometimes do, the case is not nearly so bad as is that of the lighter car.

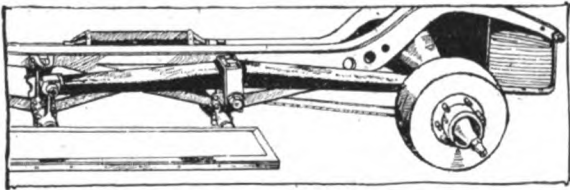

The cantilever rear spring of the Fergus car, the leaves of which are enclosed in oil-tight cases; the oil under pressure circulates right along the springs the overflow leading into the back axle

Suppose two more passengers to be added to a fully laden heavy car and also to a very light car; to the former they mean an addition of, say, 7 per cent, but to the latter something like 20 per cent of the total weight. Obviously the springs of the lighter car must have a greater factor of safety—that is to say, they must be stronger in proportion to the percentage of overload; this is the only reason why a very light car cannot be as well sprung as the heaviest car, and it is not easy to see the remedy unless the makers could issue guarantees only on the condition that their cars must not be overloaded beyond a certain point.

"It must not be assumed from the foregoing that the springing of most light or heavy cars is not open to improvement, especially in details. Notably, the practice of leaving a wearing part exposed to mud and wet and unlubricated is barbarous in the extreme. A spring is, or should be, a working part, but it does not long remain so on some cars, although the remedy is simple enough, and is seen on the Fergus car. It may be said that a certain amount of friction is useful to a spring, but it is

better to have too little than to have none at all owing to the spring being rusted up.

The Best Type of Spring

"There is, possibly, more than one opinion as to the best type of spring, it being hard to contrast the different kinds, because the conditions under which they are employed vary; but given the same conditions—that is, equality of design, workmanship, etc.—it may certainly be said that the cantilever type cannot be beaten, and it is doubtful if it can be equaled. Undoubtedly the matter of springing has not had in the past the attention which this most important part of the car merits, from most makers, anyway.

"Weight distribution also has a large influence on easy riding. The center of gravity of a car should be at or near the point of intersection of the two diagonals of the rectangle formed by the points of contact of the wheels with the ground, for, suppose that one wheel meets a pot-hole, and that the c.g. is nearer that wheel than the above mentioned point, the car will then tend to lurch toward the pot-hole, because of its own weight, but if the c.g. is central the only force tending to throw the car off an even keel will be that exerted by the spring diagonally opposite to the relaxed one, which, if it be flexible and able to move freely, will still be giving some lift. Incidentally, this position of the c.g. is also the best for reducing the tendency to skid when the direction or rate of motion has to be changed on a greasy road surface. In conclusion, we may say that good springing will become universal if, and when, it is urgently demanded by buyers of cars, which it will be if they have a better understanding of the matter."

Engines Discussed at Aeronautic Session of S. A. E.

A paper of unusual interest as regards the construction of aviation engines was presented at the first aeronautic session of the Society of Automobile Engineers which was held February 9 in the Engineering Societies Building, 29 West 39th street, New York City. This paper was given by Leigh M. Griffith, of Los Angeles, Cal., well known for his work in the design of airplane engines. The paper compares two types of construction which have been followed by aircraft designers in securing the lightest possible units. In one type it is customary to assume large dimensions for the cylinders and use low gas pressures. In the other and better type, according to Mr. Griffith, smaller cylinders and the highest possible mean effective pressures are used. The first design was largely followed in the case of air-cooled engines but the work done in the automobile industry in designing racing engines has shown that a satisfactory power plant can be built using extremely high compression pressures.

Mr. Griffith gave a detailed comparison of the weight reduction that is possible by the adoption of high mean effective pressures, showing the effect on cylinder, jacket wall and piston design. He gave some very interesting data relating to the weight reduction secured in an engine built by himself. Considerable attention was also paid to the necessity for better ignition.

In conclusion the paper stated that the highest volumetric efficiencies and compressions can be secured only by the use of multiple valves of moderate diameter.

Cincinnati Carriage Makers' January Meeting

The January meeting and dinner of the Carriage Makers' Club took place on the evening of the 11th, at the Business Men's Club. There was an attendance of 40 members.

Charles Fisher, president of the club, was home with a touch of the grip, so Howard Cox, vice-president, presided.

The speaker of the evening was Hon. Joel Clore, postmaster of Cincinnati, who gave the members of the club an insight into the workings of the Cincinnati post office. Mr. Clore was very interesting in his talk, and spoke for more than an hour. His remarks were amusing at times, and he informed his hearers of some of the very "funny" questions which arise from the public. The 1916 business of the Cincinnati post office was the largest in its history.

A. S. Brown recommended that the club should subscribe \$300 toward the publicity fund of the Cincinnati Chamber of Commerce.

The nominating committee was appointed at this meet-

builders, and that as regards the fertile territory embraced within the limits of Greater New York, the surface has not been even scratched.

Convention of Studebaker Salesmen

During the Minnesota Implement Dealers' convention held in Minneapolis early in January, Manager Keller, of the Minneapolis vehicle division of the Studebaker Corporation, held a convention of salesmen in the local office, which was attended by all the travelers and several representatives from the home office at South Bend. Mr. Keller had a space cleared on the sample floor, and the experts and heads of departments from the factory delivered lectures covering the work of the various departments and illustrated by lantern slides. The sessions covered a period of three days. A. G. Rumpf, secretary of the corporation, addressed the travelers on the subject of "Credits and Collections." L. F. Ryer, assistant sales manager, spoke on the subject of "Farm Wagons," and A. C. Hill, assistant sales manager, devoted his time to "Spring Vehi-



WAITING FOR THE 34TH STREET (N. Y.) FERRY

Photo taken on November 6, 1916

ing to select eight members for the board of governors of the club for the ensuing year. The election will take place in March. The following committee was appointed: Perrin P. Hunter, chairman; Clen Perrine, Ralph Rowalt, Alfred S. Brown and Jos. Wallenstein.

Postmaster Clore was given a rising vote of thanks for his very interesting and able talk, after which the meeting adjourned.

New York a Good Field for Motor Trucks

In the December issue of *The Hub* was printed a scene on West street, New York City, taken on August 31, 1916. It depicted an every-day scene along the water fronts of the city where a motor truck is a scarce article. The illustration on this page is from a photograph taken on November 6, 1916, showing traffic being held up by the 34th street ferry. The remarkable feature of both of these pictures is the absence of the motor truck, ample evidence that there is yet much need of exploitation on the part of metropolitan representatives of commercial motor vehicle

cles, Business Wagons and School Busses." D. O. Paulson is an expert on "Municipal Vehicles," and his time was taken up with detailed talks on construction, etc. O. S. Barrett, head of the advertising department, spoke on the subject of "Dealers' Advertising." The lantern slides were used to illustrate the lectures of the experts covering the construction of different vehicles and the work of the several departments of the business.

The travelers present included E. L. Fox, F. L. Kermott, J. A. Leahy, F. B. Stoner, P. E. Wenz and J. E. McGee. The meetings were in charge of E. E. Keller, manager of the Minneapolis vehicle division.

After completing the business sessions, Mr. Keller invited the factory representatives and the travelers to a banquet and an evening of sports at the Minneapolis Athletic Club.

The Brown Motors Co., 209 Reliance Building, Moline, Ill., recently incorporated, will manufacture an annular valve gasoline motor for pleasure and commercial vehicles.

Reinforcing Weak Car Bodies

The bodies of some of the earlier cars are a little too limber and tend to spring to such an extent when the car is driven over rough roads, that the car doors cannot be kept closed. A body that is too weak will move so that it may tear the fabric of the top apart, and it may be well worth while to brace the body with a couple of steel reinforcements, says Automobile Dealer and Repairer.

Before attaching the body reinforcements, it is necessary to loosen the bolts which fasten the body to the frame of the chassis. After the body to frame bolts have been loosened, a couple of wedges should be driven between the rear of the body and the frame. Or else the rear of the body may be lifted by a block and tackle so that the doors will be drawn into the proper position before drilling the holes for the bolts which fasten the steel reinforcements to the frame. An even easier way of drawing

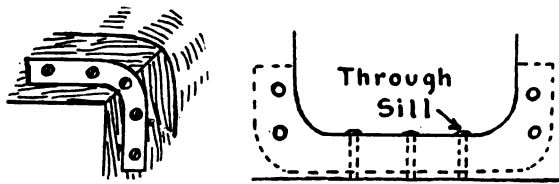

and holding the body in the proper position consists in stretching a rope or a clothes line over the front and rear supports for the top. A stick can be slipped through the rope, and the rope twisted to draw the front and rear of the body more closely together.

It is better to so adjust the body that the doors will not close by $\frac{1}{4}$ of an inch, so that after the reinforcements have been put in place and the wedges removed, a tension will be placed on the reinforcements and they will give just enough to allow the doors to open and close in the proper manner. The U-shaped reinforcements are fastened to the body sills and the sides of the door openings, two bolts going through the sides of the body at each end of the doors, and three bolts passing through the body sills.

It is sometimes necessary to use wooden strips as fillers between the steel reinforcements and the sills, because some car bodies are made with thicker wooden sills than others. The two L-shaped pieces of steel are fastened at the two rear corners of the car, and as they are fastened under the body of the car, they will not be noticeable when installed.

M. A. M. 1917 Committees

Committees of the Motor and Accessory Manufacturers for 1917 have been appointed by C. W. Stiger, president of the M. A. M. Stiger himself is, ex-officio, chairman of the executive committee, and the other members consist of C. E. Thompson, E. H. Broadwell, James H. Foster, W. O. Rutherford, Christian Girl and Alfred P. Sloan, Jr. C. E. Thompson, who is also first vice-president of the M. A. M., is chairman of the finance committee, which is identical in its membership with the executive committee.

Christian Girl heads the show and allotment committee as chairman of that committee, the other members of which are C. E. Thompson, E. H. Broadwell, J. H. Foster and William C. Rands. William M. Sweet, former manager of the association, and who for a number of years conducted the annual banquet, again heads the banquet committee, which consists of E. H. Broadwell, T. J. Wetz-

el. President Stiger, Alfred P. Sloan, who is secretary, and L. M. Wainwright, treasurer, compose the auditing committee. The one new committee that has been formed is devoted to aeronautics, and consists of Stiger, Thompson and Sweet.

Hickory and Ash

Any apprehension that hickory and ash, the most important two woods for vehicle construction, are gradually running out is probably incorrect. Professor of Forestry Berry, of the Georgia State College of Agriculture, in reply to an inquiry, says:

"There is no doubt in my mind but that there is a very large amount of hickory and ash in Georgia, but there is no data available upon the subject. In my travel about the state I have seen hickories and ash everywhere, especially in the river bottoms. Occasionally I receive inquiries from farmers stating they have considerable amounts of oak, ash, hickory and poplar. Invariably they state that the local demands are very light and that they desire me to place them in correspondence with users of the various classes of material. Some months ago I had an inquiry from New York regarding the standard ash along the Flint River. The gentleman stated that he had heard the stand was very extensive. However, I have no data as to the approximate amount of timber. We hope within the next year or two to be able to make a timber survey of Georgia."

Poppy Car to Be Made by Eisenhuth Co.

The Eisenhuth Motor Co. has been organized in California to build the "Poppy Car," which will incorporate many new features, according to the principal founder and promoter of the business, J. W. Eisenhuth. The engine has five cylinders and said to be able to start itself. The drive is direct to the rear axle by a newly patented gear which does away with the use of differentials and the transmission gearset. The motor will have but 79 parts, according to the inventor, as compared with about 225 parts in the average gasoline engine, and with the elimination of the many parts in the driving mechanism, 1,202 parts that are ordinarily found in the gasoline car have been abolished. The factory will be located at San Pedro on Los Angeles harbor on a site covering 250 acres. The "Poppy Car" will sell for \$650.

American Motors Starts Production

Production has started at the plant of the American Motors Corp. at Plainfield, N. J. W. H. Crowley, recently wholesale manager for the Saxon Motor Co. of New York, has been made a district sales manager and is on the road in New York and Pennsylvania. C. W. Govan has been made district sales manager of New England and Long Island. H. M. Applegate, former advertising manager for Lee tires is advertising manager.

Castle & Kyte Sales Agents for Hayes Wheels

F. E. Castle and H. W. Kyte have completed a transaction with the Hayes Wheel Co., Jackson, Mich., to become the general sales agents for wire wheels which this company will begin to manufacture. Mr. Kyte was formerly the manager of the Houk Manufacturing Co., and Mr. Castle has been connected with the automobile accessory industry for the past 16 years.

Paint Shop

Rapid Sign Painting

To do rapid sign work the right kind of paint and brushes are of prime importance. Colors ground in japan are the best. Enough oil should be added to serve as a binder. Japan colors look lumpy when oil is added, but will spread smoothly. Use turpentine to bring it to a working consistency by taking some shallow vessels for the turpentine and colors.

The kind of brushes to use depends on the class of work to be done, which will suggest them when a full kit is at hand. For all kinds of work the learner should supply himself with sable lettering pencils of all sizes, which are used for small work. Large signs require an assortment of camel hair brushes and fitches, from $\frac{1}{2}$ in. to as large as your work may require; also an assortment of common paint brushes. These are mostly used for filling in backgrounds. For very large work advertising sign painters use what is known to the trade as bear hair brushes for this purpose.

The first and about the hardest thing to do, says R. H. Forgrave, in *Painters' Magazine*, is to learn to make the sign fill the space and look artistic. The next important thing is to learn to sketch the layout rapidly. The hardest thing for the learner to comprehend seems to be the arrangement. He is compelled to use measurements at first, but he should try to learn to use no measurements except lines to determine the height of the letters. All other measuring in any kind of sign work is superfluous. It requires practice to do this, but he may learn if he will try, and, as he proceeds, cut out measuring with a rule as much as possible, depending on his eye to get the distances. He will make mistakes at first, but they will become fewer and of less importance with experience. The most experienced offhand sign painters make a mistake in distance once in a while, but experience has taught them how to rectify them quickly.

Some young men have an aptitude for sign painting, but the majority have not, while there are a few who cannot learn it; intelligent fellows, but they have no conception of distances or of the proper colors to use. Neither can they understand the value of light and shade. I have observed that a man who has an eye for the proper arrangement of colors, always is a good judge of distances. You may think this unimportant in making letters, but you will find the nearer you can guess the size of objects and distances between points the quicker you will learn to do free hand work.

After you have the layout fixed in your mind roughly comes the sketching. The beginner will, perhaps, require a sketch of each letter, but with study and practice he will become able to use but a few marks to determine the size and position of the letters. Some painters use only a mark or dot now and then. Some use no marks at all except lines to show the height of the letters. They have become so adept at it that they can begin at one end and fill the space artistically without any horizontal guides. Long practice has enabled them to fix just what they want in their minds and to transfer it to a surface with brushes.

If you wish a line of letters of a determined height to occupy a certain space, it is well for the inexperienced beginner to begin by getting the middle of the space. Then roughly estimate what width of letters it will require to fill it, allowing for spaces at the ends and between the letters. Begin with the middle space or letter of the line. Allow for narrow letters, I and J, if they occur and sketch the letters as they come both ways from the corner.

A line of lettering may be sketched backward as well as forward. If the space is noticeably wider at one end than at the other remember that some letter will admit of being narrowed or widened without damaging the appearance of the line. Thus, if the line ends with an E or F, H, or T, or if they occur close to the end, the horizontal stems may be lengthened or shortened somewhat and will not be noticed. This obviates the necessity of erasing the whole line and doing it over again. All letters with horizontal stems may be shortened or widened a little, the degree they will bear depends on the size. The ratio is greater as the letters increase in size. Letters such as O, Q, P, B, R, etc., should not be narrowed or widened very much from the general width of the balance, as by so doing opens or closes the center space, making them noticeable.

To sketch a line of letters they should be roughly marked with chalk or pencil, mainly to determine the space and position each is to occupy on the sign. It is not necessary to have the outlines of each letter perfect nor exactly in the space it is to occupy. Only the relative position of each letter is needed. Depend on the eye and brush to form them and get the spaces. In general, the letters should be of about the same width throughout. If, when you begin, you happen to run shy or beyond the outline of the letter, remember you can widen or narrow certain letters, as I have previously mentioned.

When "the" or "and" or other qualifying small words occur in a line of letters, they may be used to shorten the line by making the letters in such words smaller than the other letters and placing a horizontal line about and below, or above or below, as the case may be. Draw this line even with the top or bottom of the other letters. When T occurs before or after A or after L, the horizontal bar may be shortened or lengthened. If shortened, it makes the spaces at the bottom narrower than usual. If lengthened the spaces should be proportionally greater, but not so wide as to be noticeable. More care must be given to spacing small letters than large ones.

When the layout is completed, use a full pencil or brush by dipping it into turpentine and working full of color. If your paint is right and your brush full it will not run. If it starts to run there is likely too much turpentine in the brush and not enough color. Wipe some of it out and work in the paint again. If it bunches up along the edges or shows in ridges, the paint is too stout.

Begin by fixing the width of the bars in your mind. If it requires more than one stroke of the brush to form them they should be worked out to the required width.

Form the first letter in the space assigned to it, using no measure but the eye. See that the corners and angles are sharply defined.

Paint the second letter, seeing that the bars are as near as possible the width of those in the preceding letter, also that it conforms in width. Make M and W a fourth wider than such letters as P, B, H, R, etc., and A somewhat wider, but not so wide as W.

Prevention of Lead Poisoning (Painters' Colic)

Rooms or shops where painting is being carried on should be ventilated in such a manner as to remove all fumes.

Where large quantities of dry color are being used or mixed, creating dust, the work should be carried on under a proper hood provided with mechanical means for properly removing the dust.

Respirators or muzzles must be provided for and worn by workers exposed to lead dust.

Gloves should be worn by painters whenever possible.

Overalls should be worn while painting and should be washed at least once a week.

Clothing or overalls while painting should never be worn home or used as street clothes.

Proper light, fresh air, nourishing food and plenty of sleep are the best means for keeping the general health good.

Personal cleanliness is the real prevention of lead poisoning.

All painters should wash carefully before eating. Use warm water, pumice stone, a rough soap, or, preferably, a soap powder. Take a hot bath at least once a week. Finger nails should be kept short and clean. Do not permit paint to accumulate beneath the finger nails. Mouth and teeth should be washed frequently, and kept in good order by occasional visits to the dentist.

Never eat near or at work, or in paint shop, or before thoroughly washing.

Do not handle or chew tobacco or gum while using paint.

Eat well before starting work. Use plenty of milk and eggs.

Avoid the use of alcoholic liquors.

Do not hold handles of paint brushes or other implements of the trade in the mouth.

Have at least one bowel movement each day. Use a cathartic, preferably epsom salts (two tablespoonfuls in a glass of warm water) at least once a week.

Consult a physician, or go to the nearest dispensary, if you do not feel well.

Symptoms

Lead poisoning may be produced by inhaling the dust or absorbing the lead through the skin or by taking it into the stomach from lead-laden hands.

The early symptoms of "painters' colic" are loss of appetite, obstinate constipation, frequent headaches, weakness in the arms and hands, stomach cramps, extending all over the abdomen.

If means are not taken to prevent further poisoning, these symptoms may be followed by paralysis, heart and kidney disease, insanity or death.

By using common sense, soap and water, you may avoid lead poisoning.—Decorator.

Paint and the Divorce Court

The Paint, Oil and Drug Review, of Chicago, has the following humorous remarks under the above heading: A man in Kansas City is responsible for the statement that Secretary McGhan, of the Master Painters' Association, stated that the use of certain colors in wood finishing and wallpaper "has wrecked many homes which would otherwise have been happy." We do not vouch for the quotation, but, if true, this puts a heavy moral responsibility on the paint manufacturer. Just think of the care with which colors must be selected if their effect on domestic relations is so dire. We are sure that there are no wilful home wreckers in the ranks of the paint grinding fraternity, and it would seem as if the occasion demanded careful consideration when the grinders set together at their next meeting. The psychology of the situation is said to be as follows: Dark colors produce gloom. Under present conditions in the lamp black market we should think the grinders would find it easy to refrain from contributing to the general sadness. But listen to the following: Brilliant reds and purples arouse the quarrelsome instincts. It will be noticed that our greatest source of supply for reds is the seat of the present war.

Green develops jealousy and yellow produces liver complaint. White lead is believed by some to be a fruitful source of colic. Just what pigment is the source of infant paralysis hasn't yet been determined, but some wiseacre will probably discover it before long.

In short, the question seems to resolve itself into this: Shall the paint trade be branded as a peril and a menace to the public weal or shall it quit business entirely? Of course when the grinders are asked to quit, the resulting situation will involve the dealers and the master painters, so it looks as if Secretary McGhan had taken upon himself the role of Samson and was pressing hard against the pillars of the temple in which he now exists.

If Secretary McGhan had slightly modified his statement and said that the use of face paint had broken up many homes, we could have readily understood the condition referred to and given it our approval, but to attack the poor, innocent house paint in such terms seems, to say the least, ungrateful.

A Remarkable Can of Paint

The F. O. Pierce Company may not be remembered as one of the oldest paint manufacturers in the country, but an interesting incident that has just come to our attention discloses such to be the fact.

Recently when H. A. Fitch, the general manager of the F. O. Pierce Company, was calling on his friends in Montgomery, Ala., and distributors of the Pierce paints in that section, J. M. Kennedy, the senior member of the Kennedy Company, called his attention to a can of paint manufactured by the F. O. Pierce Company over half a century ago, and which, after having been sold shortly after the civil war, was returned to it in exchange for a can of paint of more modern manufacture.

The story told of this can of paint by Mr. Kennedy is something as follows: About eighteen months ago an elderly lady came into their store with a package and asked one of the clerks if he would exchange a can of paint which had been bought from them, to which question the clerk promptly assured her that he would be glad to do so. Upon unwrapping the clerk was shocked to notice the can antedated anything of the kind he had ever seen, and while

the label was very much worn and the letters hardly decipherable, he read the name "A. M. Kennedy" thereon, which was the name of the Kennedy Company prior to 1886.

Upon the matter being called to the attention of Mr. Kennedy, he made inquiries and found the lady lived at a little town 15 miles away and that the paint was the last of a lot that had been sold her father shortly after the civil war.

Mr. Kennedy was unable to fix the exact date when the can of paint was sold, but he is of the opinion that it was part of a lot his father had bought before 1861, which would make it over 55 years old. It seems the elder Mr. Kennedy had been buying the same line of paints prior to that time, but when the civil war broke out he enlisted in the Confederate army, where he served four years, but before going into the service he hid a large part of his

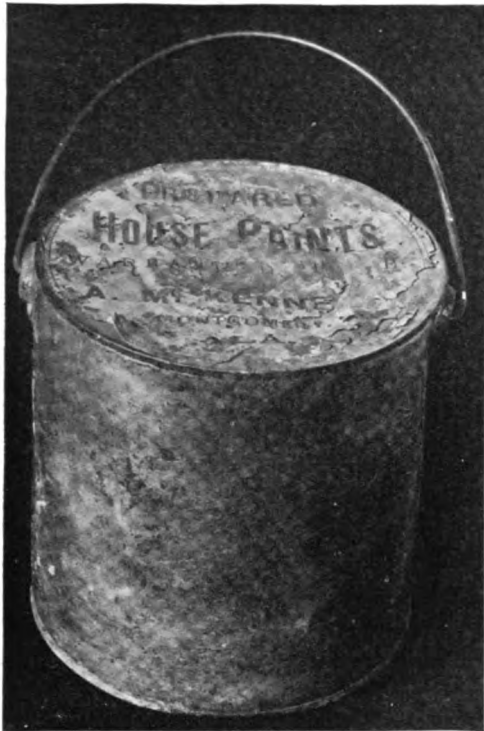

What it looks like

stock of paints under his stable, where it remained all during the conflict, and this can is part of that lot.

Mr. Fitch was so impressed with the incident that he managed to induce Mr. Kennedy to part with the can of paint, and brought it to his New York office.

The remarkable part of this story is the good appearance of the can after all these years, and upon shaking it up its contents seem to be holding in suspension and are apparently as well mixed as ever.—Paint and Varnish Record.

Quickwork Co. Succeeds H. Collier Smith

The Quickwork Company of Ohio has been organized for the purpose of taking over and operating the machinery business of H. Collier Smith, Detroit. Mr. Smith retains the controlling interest and will have active charge of the operations of the company.

The company is capitalized at \$400,000, there being no bonded or mortgage indebtedness. The personnel of the management of the business will remain unchanged, H.

Collier Smith being president and general manager; H. E. Groves, vice-president; A. F. Smith, secretary and treasurer; K. J. O'Leary, production manager; R. H. Sims, sales manager, and Harry G. Smith, head of the engineering department.

Quickwork machines will be manufactured at St. Marys, O., where the company has purchased a modern, well-equipped plant on 21 acres within the city limits. A branch office, sales rooms and show rooms will be maintained in Detroit as heretofore.

A Missouri Wagon Work Price List

The following list of prices went into effect on November 1. Some old prices are given so that the amount of advance can be readily seen:

	New Prices	Old Prices
Wagon Circle, Hounds.....	\$4.00	\$3.50
Wagon Spokes, each.....	.25	
Wagon Spokes, all in wheel.....	.20	
Wagon Felloes25	
Buggy Tongues	3.50	3.00
Buggy Tongues Circle.....	1.00	
Buggy Shafts, each.....	1.75	1.50
Buggy Shaft Cross Bar.....	1.00	.75
Wagon Tongues	3.50	3.00
Wagon Axles, 4½ and under.....	3.50	3.00
Wagon Bolsters, new, complete.....	4.00	3.50
Wagon Bolsters, old irons.....	2.50	2.00
Sandboards	2.00	
Wagon Tongue Hounds, each.....	1.00	.75
Wagon Hind Hounds, each.....	1.25	1.00
Wagon Reaches, 12 ft.....	1.25	
Buggy Reaches, straight, each.....	1.00	.75
Buggy Reaches, double bend, each.....	1.50	1.00
Cutting Down Wagon.....	10.00	9.50
Setting Four Wagon Tires.....	2.50	2.00
Setting Four Wagon Tires, drill and bolt... ..	3.50	3.00
Setting One Buggy Tire.....	.65	.50
Four New Buggy Axle Stubs, 1 in. and under	8.00	6.00
Four New Buggy Tires.....	8.00	6.00
One New Buggy Tire.....	2.00	1.50

Tuthill Spring Expands Service

The Tuthill Spring Co., Chicago, manufacturers of automobile springs, has increased its production considerably. Among the most important of its additions to its equipment consists of a number of special fitting machines, which give a more perfect fit of one spring leaf upon another than has been possible heretofore in replacement work. Spring action and capacity being conditioned by the distribution of the load on the spring leaves, and that being dependent on their accuracy of fit, the importance of the new equipment may be understood.

Brooklyn Auto Show Will Exhibit Trucks

Brooklyn, N. Y., annual automobile show will be held February 24 to March 3, in the 23d Regiment Armory. As usual, commercial cars will be shown, as well as pleasure cars, the only exhibition of motor trucks in Greater New York. The armory has more floor space than the main floors of either the Grand Central Palace or Madison Square Garden, and has only a small balcony. All space has been taken.

Difficulty of Melting Scrap Aluminum

The melting of aluminum scrap, particularly chips from machine shops, might, to the uninitiated, appear a very simple process. How difficult it is to perform without excessive loss through oxidation is, however, made abundantly clear by Bulletin 108 recently issued by the Bureau of Mines. This bulletin has 88 pages devoted entirely to this matter. The book is very interesting reading even to an engineer not too closely acquainted with foundry practice and in it, in addition to much very valuable information, there are some interesting figures regarding the quantity of aluminum absorbed by the automobile industry. It is stated that a conservative estimate of the amount of aluminum employed in automobile manufacture in the United States from July 1, 1914, to June 30, 1916, was 50,000,000 pounds.

The percentage machined off from a rough aluminum casting in the finishing process seems, from data obtained by the writer, to average about 15 per cent, a figure which is much higher than was estimated offhand by several people connected with the automobile and aluminum casting industries, whose guesses average 3 to 4 per cent. The writer's result was reached by weighing rough and finished castings at an automobile plant making a car in the \$700 to \$800 class, and by weighing rough and finished castings made for various other motor car manufacturers at an aluminum foundry, with the results shown in the accompanying table.

PROPORTION OF METAL MACHINED-OFF ALUMINUM CASTINGS

Casting	Weight of Rough Casting, Pounds	Weight of Finished Casting, Pounds	Percentage of metal machined off, Per Cent
Gear and transmission case.....	28.50	24.50	14
Small double-flanged exhaust elbows	.42	.35	15
Intake pipe for six-cylinder motor..	5.00	4.80	4
Gear case for small motor.....	8.90	7.00	21
Gear case for very small motor.....	1.58	1.50	5
Crankcase for eight-cylinder motor.	94.00	80.00	14.5

The results of the tabulation, which indicate that 15 per cent was machined off, were so at variance with the estimates cited that the matter was taken up with the makers of a car in the \$2,000 class, who state that on that car there are used 47 aluminum parts which are machined, the total weight of the rough castings used per car being 166.19 lbs. The loss per car in chips is 25.15 lbs., or 15.1 per cent. The weights were taken on the average of a number of like parts, in some cases as many as 50 being weighed. On the basis of 15 per cent of metal machined off, the yearly production of chips from aluminum castings in the United States will then run between 3,000,000 and 3,750,000 lbs. If 20 to 30 per cent of this amount is unnecessarily lost, then 600,000 to 1,125,000 lbs. of aluminum alloys worth 16 to 25 cents per pound, based on the average market quotations in normal times, is lost.

Napier Detachable Wire Wheel Patent Invalid

A long standing dispute covering the basic patent of a detachable wire wheel, that is a wire wheel in which the wheel can be removed, leaving the hub with its bearings in position on the axle, was recently settled in England. This patent was for years held by J. S. Napier, formerly of the Arrol-Johnson concern, and who licensed the majority of the wire wheel manufacturers in England. The courts have decided the patents invalid and consequently any person is free to manufacture detachable wire wheels. This decision does not in any wise affect the validity of

the many patents covering different methods of attachments as well as locking devices.

Will Manufacture Hazard Engines

The truck engine formerly known as the Hazard will be built commencing next summer by the North American Motors Co., Pottstown, Pa., which has acquired the assets of the North American Motor Co., and the Potter-Mackie Mfg. Co. The president of the company is Edmund J. Levine. It is expected that a plant for the manufacture of 20, 30, and 45 h. p. engines will be completed during the coming summer.

Rood Leaves F. S. Carr Co.

W. B. Rood, vice-president in charge of sales of the F. S. Carr Co., of Boston, has disposed of his holdings and retired from the company. Rood has made an enviable record in the placing of the Neverleek fabrics on the market.

Mr. Rood is a graduate of the tire business, having come originally from Akron, O. He intends to take an extended vacation before disclosing the plans that he is formulating for the future.

Association Will Test Brake Linings

The Asbestos Brake Lining Manufacturers' Association will carry out tests of brake lining for the purpose of giving its members direct and accurate information as to the advantages or otherwise of various systems of making linings; this work is to be in addition to such matters as are more usually handled by trade associations. The tests will be carried out in a laboratory well equipped for the purpose.

Boston Auto Show and Salon

Boston is to have not only its regular automobile show in March in Mechanics' Building, but also a salon at the Copley Plaza, where cars of more than ordinary luxury will be shown. Boston's two exhibitions, however, will be conducted by the one organization, the Boston Automobile Dealers' Association, under the management of Chester I. Campbell, as usual. About 30 makes are to be shown at the hotel.

New Exhibition Building for New York

New York City is to have additional exhibition space, seating 40,000, according to plans which are being formulated for the construction of a large amphitheatre to occupy an entire city block some place between 42d and 59th streets and Fifth and Seventh avenues. The building is to cost between \$7,000,000 and \$8,000,000, and is expected to be finished next year.

Weart Heads Bound Brook Bearing

Spencer Weart, formerly vice-president and secretary of the Bound Brook Oil-Less Bearing Co., Bound Brook, N. J., has been elected president of the company. George Smalley, formerly second vice-president, has been made first vice-president and general manager. W. F. Jennings is eastern sales manager of the company; H. J. Lindsey, western sales manager at the Detroit office, and the appointment last January of A. K. Smith as production manager has been confirmed.

Thirteenth Annual Dinner of the Technical School Alumni

The thirteenth annual reunion and dinner of the Alumni Association of the Technical School for Carriage Drafts-fen and Mechanics of New York, was held on January 5, at the St. Denis Hotel of that city.

The committee in charge, having made a special effort to attract a large attendance during the Automobile Show week, was more than repaid by the number of members and guests attending.

President Riepe, who presided at the dinner, spoke at some length of the benefits derived from a course of study embodying the principles of drafting relating to coach work. He voiced the opinion of all of the officers in describing the value of members keeping in touch with the association wherever they were located.

In appreciation of the services rendered by Prof. Johnson during the past years, the alumni members presented him with a silver loving cup, on this, his 25th year with the school.

Prof. Johnson, in acknowledging the gift, reviewed the history of the school during the long period he was connected with it, and recalled many incidents of interest which had happened since its organization in 1882, with a small attendance, until the present time, with its modern and commodious quarters and its graduates scattered over the entire world.

Members all over the country, who were unable to attend, sent letters and telegrams of congratulation to both the school and Prof. Johnson.

One of the speakers was Mr. Baldwin, secretary of the Y. M. C. A. at 222 Bowery, in whose building the school had its quarters for many years. He was warm in his praise of the men, who, working hard during the day, still had the time to devote to study and training at night. He congratulated the school upon having a man of Prof. Johnson's abilities at its head.

Mr. Wilson, one of the school's best friends and strongest supporters, discussed carriage drafting from a business standpoint. He pointed to the great strides made by the automobile industry in the past few years and the necessity manufacturers find for the employment of the coach builder's art. This he contended was only a beginning and he prophesied a brilliant future for the school and the members fortunate to be its graduates.

Many of the others present discussed different aspects of the trade in which all were interested and when the time of adjournment came, all voted the evening a success.

The officers elected for the ensuing year are: President, August Riepe; vice-president, John S. Burdick; historian, Andrew F. Johnson; secretary and treasurer, Jacob H. Klein.

Luth Calls Conference of Carriage Manufacturers

Theodore Luth, president of the Carriage Builders' National Association, has called a special meeting of active carriage manufacturers of America, to be held at the Hotel Gibson, Cincinnati, at 10 a. m. Thursday, February 27. The most important business to be taken up at the session will be the tremendous increase in the cost of material for building carriages, which was responsible for individual manufacturers recently increasing their prices.

Empire Rubber Reorganized

The Empire Rubber & Tire Co., Clinton and Mulberry streets, Trenton, N. J., has been reorganized with a capital of \$4,500,000 to provide for increased operations in the manufacture of automobile tires and mechanical rubber goods. J. E. Baum, president of the Supplee-Biddle Hardware Co., Philadelphia, has been elected president of the company; E. B. McKay, formerly Chicago manager, has been elected vice-president in charge of plant operations. It is said that the present capacity of the plant will be doubled during the year.

Enger Protected Company

Frank J. Enger, president of the Enger Motor Car Co., Cincinnati, O., left full directions for the conduct of the business when he committed suicide recently. His act was premeditated, no doubt, for a long time as he had been ill and despondent for years, and on his desk was found a letter to E. L. Jones, general manager of the business, giving detailed instructions. In this way Enger protected both his estate and Enger dealers against feeling any evil effects from his death.

Forgy Heads Locomobile Purchasing Department

The many friends of J. Forgy Edmonds will be pleased to learn of his well-merited promotion to the head of the purchasing department of the Locomobile Co., of Bridgeport, Conn., on February 15, when C. C. Ostrom resigned that position to become associated with the Parish Mfg. Co., of Reading, Pa., and Detroit. Mr. Edmonds has been connected with the Locomobile Co. for some years as assistant purchasing agent.

Death of E. Louis Kuhns

E. Louis Kuhns, for many years connected with the Studebaker Corporation and its predecessor, the Studebaker Bros. Manufacturing Co., died suddenly in New York, Feb. 13. Mr. Kuhns was a son-in-law of J. M. Studebaker. For a long time he was connected with the sales department of the Studebaker institution, and later placed in charge of its branch house in Chicago. About two years ago he was transferred to New York.

Japanese Company to Make Cars

Japan manufacturers are to enter the automobile business. The Nippon Sharyo Kaisha (Japanese Vehicle Co.) will manufacture cars in designs adapted to the peculiar needs of Japan. The company will make 10 h.p. cars with accommodations for four passengers. These cars will be of the width of a jinrikisha and will consume cheap petroleum. Their selling price will be about \$500.

Fiat Co. to Build Small Car

The F. I. A. T. Co., Poughkeepsie, N. Y., will invade the medium-priced automobile field as soon as peace is declared. As soon as the war is over, the Fiat company will enlarge its Poughkeepsie plant to nearly ten times its present size and will produce on a large scale a car selling around \$2,000. The arrangements for building a medium-priced car will not mean the discontinuing of the higher-priced models.

Trade News From Near and Far

General News of the Vehicle Trade

The Trudeau Carriage Co., Montreal, has been incorporated with a capital of \$49,000.

The Dort Motor Car Co., Flint, Mich., has increased its capital from \$500,000 to \$1,500,000.

The Page Bros. Buggy Co., maker of automobile tops, Marshall, Mich., is planning to increase its output.

The Chalmers Motor Co., Detroit, has acquired 13 acres of land for the erection of an addition to its plant.

The Wapakoneta (O.) Wheel Co. is increasing the capacity of its plant to manufacture automobile wheels.

Plans are being drawn for a foundry, 60 x 100 ft., to be erected by the Emerson Motor Co., at Kingston, N. Y.

The Bimel Spoke & Auto Wheel Co., Portland, Ind., has increased its capital stock by issuing \$50,000 preferred.

The Macon (Mo.) Motor Co. has increased its capital stock from \$2,000 to \$600,000 for improvements to its plant.

A. J. Miller Co., Bellfontaine, O., will erect a three-story plant to use for assembling automobiles and for offices.

The Russell Motor Car Co., King and Mowatt streets, Toronto, will erect an addition to its factory to cost \$14,000.

Olympian Motor Co. has bought the old Cartercar factory and 15 acres of land at Pontiac, Mich., for expansion purposes.

The Ford Motor Co., Ford City, Ont., is making arrangements for a concrete addition to its plant at London, Ont., to cost \$25,000.

The Hackett Motor Car Co., Jackson, Mich., is preparing plans for a new factory in Grand Rapids, Mich., to be completed in the spring.

A new building, 50 x 160 ft., is being constructed for Laird & Kastner's Carriage and Wagon Works on Campbell street, near Twelfth, Kansas City, Mo.

The Maxwell Motor Sales Corporation has leased 30,000 sq. ft. of floor space in the plant of the St. Louis (Mo.) Car Co., which it will use for a temporary assembling plant.

The new malleable iron foundry of the Timken-Detroit Axle Co., in Canton, O., is nearing completion and it is expected that it will be ready for operation some time next month.

The Sparks-Withington Co., Jackson, Mich., manufacturer of the Sparton automobile horn and automobile parts, has built an addition which will double the capacity of its plant.

The Schwarz Wheel Co., Margaret street, Philadelphia, manufacturer of automobile wheels and parts, has acquired property about 160 x 200 ft., adjoining its plant, to be used for extensions.

The Hess-Bright Mfg. Co., Philadelphia, manufacturer of ball bearings, pulleys, hangers, etc., is having plans prepared for a two-story steel and concrete addition to its plant, 80 x 200 ft.

The Stults Motor Co., Ft. Wayne, Ind., has been incorporated with \$25,000 capital stock, to manufacture motor vehicles. The directors are A. W. Stults, J. R. Stults and David L. Henniner.

The Dundore Mfg. Co., capitalized at \$75,000, will manufacture automobiles and automobile parts at Reading, Pa. Those interested are Charles S. Dundore, Edwin S. Smith, W. Stewart Wray and D. Elmer Worley.

A motor car assembling plant with an annual capacity of 12,000 cars will be equipped at Kansas City, Mo., by the Maxwell Motor Car Co., of Detroit, Mich. A four-story building is to be erected for the purpose.

The H. H. Franklin Mfg. Co., maker of the Franklin car, is now turning out 30 cars a day, or at the rate of 9,000 a year. This is double the rate of production a year ago, the increased business having necessitated large additions to the plant.

The Torbensen Axle Co., Cleveland, O., is planning the construction of an addition to its machine shop that will provide 30,000 sq. ft. of space. The contract for the building itself has been placed, and the company is now receiving bids on equipment.

Work is being rushed on the addition to the plant of the Regal Motor Car Co., Detroit. The new building is to be used for assembly purposes, and is being erected adjacent to the present assembly building. It will nearly double the assembly facilities.

The Eastern Motors Syndicate, manufacturer of the Charter Oak car, has leased a plant in New Britain, Conn., containing about 15,000 sq. ft. of floor space. The building is one story and 118 x 110 ft. The initial appearance of the car will be at the Boston Show in March.

Apperson Bros. Automobile Co., Kokomo, Ind., has transferred all of its machinery from the old plant to the new, which gives it an additional floor space of nearly 500,000 sq. ft., and practically doubles the acreage of its buildings. Nearly \$300,000 has been invested in new machinery and buildings.

The Spranger Rim & Wheel Co., 163 Beaubien street, Detroit, has changed its name to the Spranger Wire Wheel Co., and increased its capital stock from \$100,000 to \$300,000. It is constructing a new factory where all manufacturing will be done in the future. The directors are J. A. Lancaster, H. E. Adams and J. Robert Wilkin.

The Diamond T Motor Car Co., Chicago, is to have a new plant, to be built at a cost of \$1,000,000 upon property just bought at 26th street and Kilbourn avenue. The land has 415,000 sq. ft., and has been purchased by an investor who will also erect the buildings, which will be leased by the Diamond T company for 25 years.

The Bethlehem Motor Corporation, recently organized in Allentown, Pa., is arranging to erect the initial buildings of its proposed plant for the manufacture of commercial vehicles. The plant will be on property acquired along the New Jersey Central Railroad and will be equipped to produce 2,000 trucks the present year.

The Majestic Motor Co., 1790 Broadway, New York, at present is manufacturing its eight-cylinder automobile at its plant in the city. At such time as it does build its own plant it will probably locate either in Long Island City or The Bronx. The company was capitalized recently at \$1,000,000. F. A. Kateley is vice-president and general manager.

The Saxon Motor Car Co., Detroit, will push work on its new factory and the installation of machinery, due to a \$200,000 fire which completely destroyed the present plant. The new factory was to be completed May 1, but every effort will be made to put it in operation before that time. The company employs 2,000 men. Harry W. Ford is president.

The Mitchell Motors Co., Racine, Wis., has completed a new five-story body and sheet-metal shop and will build a one-story concrete and steel machine shop addition to its plant No. 1 of the main works. Other improvements under way will double the capacity and afford a production of 25,000 cars for 1917. Otis C. Friend is president and general manager.

The Hamilton Motors Co. has been incorporated with a capital stock of \$500,000. The company is established in a new plant at Grand Haven, Mich., and production of cars will begin February 1. Guy Hamilton is designer of the car. Announcement of officers will be made shortly. The enterprise was undertaken by prominent stockholders of the Alter Motor Car Co.

The Studebaker Corporation, Detroit, Mich., will shortly begin the erection of a large continuous gray-iron foundry in South Bend, Ind., for making automobile and vehicle castings, and also a new forge shop. The foundry will be a two-story building, 140 x 450 ft., and will have three cupolas. The forge shop will be 160 x 200 ft. Conveyors, cranes and other foundry equipment will be required.

Doings of the Motor Truck Builders

Gray Motor Truck Co., Gary, Ind., is asking bids on an assembling plant, 110 x 120 ft., to cost \$9,000.

The Nash Motor Co., Kenosha, Wis., will largely increase the output of Jeffery Quad trucks during the current year.

The Garford Motor Truck Co., Lima, O., manufactured over 3,500 trucks during 1916. The value of the machines was more than \$5,000,000.

The G. A. Schacht Motor Truck Co., Cincinnati, O., has filed papers in that state to increase the authorized capital stock of the company from \$35,000 to \$100,000.

Champion Motor Car Co., Fulton, Ill., started production in its reconstructed factory February 1. The output within six weeks will be 270 light-delivery cars per week.

At the annual meeting of the Cadillac (Mich.) Auto Truck Co., Secretary Helm reported that more than 200 trucks had been made and shipped during the company's first year.

The Brockway Motor Truck Co., Cortland, N. Y., has had plans prepared for a one-story cement block addition to its machine shop, 50 x 200 ft. George A. Brockway is president.

The Gerlinger Motor Car Co., of Tacoma, Wash., has sold its plant in that city to the Gersix Motor Truck Co. and will occupy a new plant now in course of construction at Portland, Ore.

The American Motor Truck Co., manufacturer of motor trucks and incorporated for \$600,000, will begin work within 30 days on a plant in southwestern Detroit on the Michigan Central tracks.

As a result of the reception of the new one-ton Maxwell truck exhibited in the Hotel Biltmore during show week in New York, definite plans for a production of 15,000 of the vehicles have been formulated.

It is reported that the Ford Motor Co., Detroit, will produce a truck and will have it ready to sell by April 1. The reports add that the company has contracted for material for 250,000 of these trucks.

The Brazil Motors Co., of Brazil, Ind., just incorporated with a capitalization of \$150,000, has purchased the plant of the Brazil Fence Co., and will engage in the near future in the manufacture of a front-drive motor truck.

The Lamson Truck and Tractor Co., formerly known as the Zeitler & Lamson Truck Co., Chicago, has completed an addition to its plant. Additional space, it is said, will be needed before the expiration of the year.

The Capital Truck Co., Indianapolis, has been incorporated with \$10,000 capital stock to manufacture automobiles, trucks and tractors. The directors are Charles A. Edmonson, Paul W. McElroy and Arthur O. Stanley.

The Redden Truck Maker, recently taken over by a corporation capitalized at more than \$1,000,000, will begin manufacturing in the plant at the Briscoe Automobile Co., Jackson, Mich. Additions will be made to the Jackson plant.

Graham Bros., Evansville, Ind., are offering a unit for converting the chassis of the Ford car into a one-ton truck. The unit is priced at \$350, and includes not only the necessary chassis parts but driver's cab and flare board express body.

The Smith Motor Truck Corp., Chicago, has started its second new plant. The plant will be a duplicate of the one erected last year in record time, capable of a production of 300 Smith Form-a-Trucks per day. The plant is to be ready for occupancy May 1.

The Four Wheel Drive Automobile Co., Clintonville, Wis., reports that orders on hand January 1 were of such volume as to occupy all of the recently enlarged facilities for more than six months. Further extensions will be made as soon as the frost leaves the ground. W. A. Olen is president.

A brewing company in Davenport, Ia., has formed the Independent Auto Truck Co. and will market machines made like those it has turned out for its own use. The truck will have a capacity of one ton, will sell for \$1,100, and will use the Continental engine. An internal gear axle will be used, and a number of other standard parts, the general design being more or less conventional.

Jerry W. DeCou, factory manager for the Thomas B. Jeffery Co., Kenosha, Wis., who resigned shortly after it was taken over by the Nash Motors Co., has been appointed general factory manager for the Smith Form-a-Truck Co., Chicago. He already has started on his new work, and expects to turn out 50,000 Smith truck units by the end of the year, increasing the present output rate to 200 a day at least.

The Globe Motor Truck Co., formed by J. H. Eddy and F. N. Woodward, Detroit, Mich., has taken over the plant of the National Iron Works, at East St. Louis, Ill., which will be remodeled and reequipped. The men to have

charge of the operation of the plant will be drawn from the company's present plant at Northville, Mich. St. Louis directors are John F. Hines, Christopher Beckermeyer, Jr., William H. Corcoran, Louis Fusz, David A. Marks, Wm. C. Mierher and George E. Raithel.

The Dearborn Motor Truck Co., Chicago, has reorganized as the Dearborn Truck Co. and the capital has been increased to \$550,000, of which \$200,000 is to be preferred stock. S. D. Porter, formerly vice-president and general sales manager of the Smith Form-a-Truck Co., has purchased an interest and become vice-president, treasurer and general manager. W. J. Kenrick remains as president of the new company. C. E. Stuart, formerly assistant general sales manager of the Smith Form-a-Truck Co., has become sales manager of the new company.

Stegeman Motor Car Co., Milwaukee, manufacturing Stegeman worm-drive trucks in 1½ to 7-ton capacities, will more than double capacity. The company is erecting a new assembling shop, 150 x 240 ft., one-story, with saw-tooth roof, and a new building for administrative purposes, 65 x 100 ft., one-story and basement. The present assembly shop will be turned over to the manufacturing department and considerable new tool equipment will be added. The company will build its own transmissions and rear axles. The output of trucks will be increased to nearly 1,000 a year.

The Millington Motor Car Co., Chicago, has entered the field with the Front-Away light delivery truck. It drives through the front axle and carries its frame unusually low. It will be made in both a delivery and runabout form, the delivery model to have a 1,000-lbs. capacity and to sell for \$675. The front axle is a live one, with two bevel driving gears transmitting the drive by universals inclosed within globular steering knuckles. The chassis has wire wheels with pneumatic tires and the rear axle is of the dropped type to clear the low frame. Semi-elliptics are used all around, the front ones being shackled at the front and pinned at the rear, thus taking propulsion by a pull instead of a push and making for steadier steering.

Body Builders Briefs

The Bela Body Co., Framingham, Mass., is receiving bids for an addition 100 x 150, one story.

Fisher Body Corp., Detroit, is erecting a new five-story factory having the latest modern improvements.

The Liberty Body Co. is being organized in Detroit to make commercial bodies. Prominent men of the industry are said to be interested.

The Maxwell Motor Co., Detroit, has leased the Manufacturers Production plant in Dayton, O., and intends to make closed bodies there.

Brewster & Hiltmeyer, San Francisco, have leased quarters at Los Angeles and Fourteenth streets, to engage in the manufacture of automobile bodies.

The Porter Body Co., Ann Arbor, Mich., has been incorporated by Gilbert E. Porter, Ray C. and Glen E. Killins, with \$10,000 capital to manufacture automobile bodies.

The Lansing (Mich.) Wagon Co. has changed its name to the Lansing Body Co., and will build new shops at once. It specializes in motor omnibus, hearse and ambulance bodies.

William Nantarro has been appointed superintendent of the body building department of the Kent Motors Corp. factory, Newark, N. J. He was formerly with J. M. Quinby & Co., Newark.

The Briggs Mfg. Co. has contracted with the Harroun Motors Corp. for the assembling and trimming of Harroun bodies, and will use a part of the Prouty & Glass plant at Wayne for that purpose.

The Goodman Auto Body Co., 1737 Broadway, New York, builder of special automobile bodies, has increased its capital stock from \$5,000 to \$25,000 in order to take care of its increased business. Henry Goodman is president.

The Martin Carriage Works, York, Pa., will be taken over by the Martin Truck and Body Corp., which has been organized with a capitalization of \$300,000 preferred and 30,000 shares of common stock. The present plant has a capacity of 20,000 vehicles a year.

The All-Season Body Co., Marshall, Mich., with offices at Jackson, has been incorporated with \$500,000 to manufacture detachable automobile tops and accessories. J. A. McAvoy, Mansel Hackett, Ralph Trese and F. R. Bothwell, all of Jackson, are the incorporators.

The Chicago Auto Painting Co., 2441 South Michigan avenue, Chicago, builder of automobile bodies, will build a three-story factory, 46 x 124 ft., at Michigan avenue and Twenty-fourth street. The work is in charge of M. Zutman and the building cost is estimated at \$30,000.

The Sedan Body Co., Union City, Ind., will complete its new building in June. The brick structure will be two stories and will have 54,000 sq. ft. floor space. C. C. Adelsperger is president and general manager, and C. C. Koontz is secretary and treasurer. Two hundred men will be employed.

Le Munyon & Bidelman is a new firm at 1416 South Los Angeles street, Los Angeles, Cal., and are making two styles of bodies for Ford cars. They make the L. & B. truck, chain and worm drive, one-ton capacity. The factory is at Alhambra, Cal., where the concern is also making trailers.

The Allen Motor Car Co., Fostoria, O., will build a large body plant and recently sold \$110,000 worth of stock for that purpose in 15 minutes after outlining their plans to 300 members of the local Chamber of Commerce. A new company will be organized to operate the plant under the name of the Dale Body Co.

Fitzgibbon & Crisp, Inc., Calhoun street, Trenton, N. J., recently increased its capital stock from \$100,000 to \$200,000 to take care of its growing automobile body business, which is being increased by the building of steel hand and power dump bodies for contractors and builders. L. L. Woodward is secretary and treasurer.

E. J. Lang, formerly retail sales manager of the Baker R. & L. Co., and son of Charles E. J. Lang, founder of the Rauch & Lang Carriage Co., Cleveland, O., has resigned, effective February 15, and will go into business for himself, manufacturing automobile bodies. Mr. Lang has been with the Baker R. & L. Co. for 12 years.

P. J. Blaser has reorganized the Blaser Auto Body Co. at Fostoria, O. The new company, of which Mr. Blaser is president, is rebuilding the plant of the Kressler Automobile Co., which was destroyed by fire November 16. The company will manufacture bodies of various kinds, especially of the closed types, for wholesale and retail businesses.

The Bay City (Mich.) Commercial Auto Body Co. has been organized in Bay City, Mich., with a capital of \$25,000, mostly supplied by local individuals. The first six months' experimental stage of the company was backed by the Board of Commerce and encouraged the men so much that it was decided to incorporate. The company plans building a new factory.

The Springfield Body Corp. at its annual stockholders' meeting reported that the Detroit plant is 75 per cent completed and that the corporation would be shipping bodies from this plant within 60 days. The company has licensed 13 manufacturers to build the Springfield type body on a royalty basis and 32 automobile companies have adopted it as standard equipment.

The Auto Body Co., Appleton, Wis., has been organized by D. H. Pierce and Gustave Seeger. All types of bodies will be made for passenger cars and trucks. The company, which is occupying temporary quarters in the former Schneider shops, is rebuilding the structures at Fremont and Jefferson streets for permanent use. Much new wood and metal-working equipment will be installed.

The Metropolitan Auto and Carriage Co., Bridgeport, Conn., is building a large addition to its present factory, which, when completed, will give the company 28,000 sq. ft. of floor space, devoted exclusively to the manufacture of commercial automobile bodies. New elevators being installed will permit the handling of trucks as heavy as ten tons. Much new equipment is going into the factory, and a modern up-to-date plant is being evolved.

The Blue Ribbon Auto and Carriage Co., Bridgeport, Conn., has been taken over by the Blue Ribbon Body Co., a new company with increased capital, which plans to expand the company's body building business largely. E. A. Godfrey, president, and George H. Woods, secretary and treasurer of the old company, continue in the same offices in the new, and no change is to take place in the management. Additional land has been purchased and plans made for the construction of new buildings. The company is well known throughout New England as a maker of fine bodies and is well patronized by dealers and distributors having orders for custom bodies.

WANTS

Help and situation wanted advertisements, 1 cent a word; all other advertisements in this department, 5 cents a word; initials and figures count as words. Minimum price, 30 cents for each advertisement.

PATENTS

Patents—H. W. T. Jenner, patent attorney and mechanical expert, 606 F St., Washington, D. C. Established 1883. I make a free examination and report if a patent can be had and exactly what it will cost. Send for circular.

FOR SALE

For Sale—"Motor Body Work for Commercial Cars," a new text book dealing with the construction of all types of bodies for business purposes. Contains also six working drawings and a glossary of technical terms, together with diagrams and sketches. Price, \$1.20 net; by post, \$1.56. Orders should be accompanied by remittance. Cooper's Vehicle Journal, Ltd., 19 Garrick street, Long Acre, London, England.

Index To Advertisers

Acme Die-Casting Corporation.....	38
Barrell Co., Wm. L.....	4
Bela Body Co., The.....	39
Bliss, E. W., Co.....	3
Bookwalter Wheel Co.....	42
Bradley, C. C., & Son.....	41
Brawley, T. R.....	43
Brennan Motor Mfg. Co.....	43
Columbus Bolt Works.....	Back cover
Cowles, C., & Co.....	42
Crane & MacMahon, Inc.....	Back cover
Decker, J. C.....	42
Dowler, Chas. L.....	42
DuPont Fabrikoid Co.....	4
Eccles, Richard, Co.....	4
Hoopes Bro. & Darlington.....	43
Hotel Brunswick	41
Hotel Tuller	38
Jenner, H. W. T.....	37
Johnston, R. F., Paint Co.....	42
Keratol Co., The.....	4
Laidlaw Co., The.....	2
Lumen Bearing Co.....	3
Millersburg Fifth Wheel Co.....	42
Mulholland Co., The.....	42
Murcott-Duden Co., The.....	2
O'Bannon Corporation	42
Parsons Mfg. Co.....	2
Pettingell Machine Co.....	7
Pierce Co., F. O.....	Back cover
Porter, H. K.....	43
Pressed Steel Co. of New York.....	2
Rome-Turney Radiator Co.....	40
Russell, Burdsall & Ward Bolt & Nut Co.....	41
Sheldon Axle & Spring Co.....	6
Skinner, J. M., Bending Co., The.....	38
Smith, H. Collier.....	43
Smith Wheel, Inc.....	Front cover
Standard Oil Cloth Co., Inc.....	5
Technical School for Automobile Draftsmen.....	41
West Tire Setter Co.....	43
White-Quehl Mfg. Co.....	42
Wilcox Mfg. Co., D.....	43
Willey Co., C. A.....	42
Williams, J. H., & Co.....	8
Wing, Chas., Co.....	42

Acme Die Castings

in Aluminum and White Metal Alloys

Accurate, Strong, Tough, Smooth, Economical

There are special features in the Acme patented process of die-casting intricate parts in either aluminum or white metal alloys that are important to manufacturers. Porosity is reduced. Strong, tough, smoothly finished, accurate castings wherein each part fits perfectly as designed are the result of our expert knowledge of this work.

The cost of Acme die-castings in quantities cast by our special patented process is low when compared with former methods of production.

Our complete equipment and thorough organization enables us to render you highly satisfactory service. Let us give you estimates at once from your model or blue prints.



Acme Die-Casting Corporation
 Bush Terminal Bldg. No. 5, 5th St. and 3d Ave.
 Brooklyn, N. Y.

Boston—176 Federal St.
 Philadelphia—Widener Bldg.
 Detroit—965 Woodward Ave.

Chicago—549 Washington blvd.
 Canadian Distributors:
 Lyman Tube & Supply Co., Ltd., Montreal



Meet me at the Tuller for Value, Service, Home Comforts

NEW
HOTEL TULLER
 Detroit, Michigan

Center of business on Grand Circus Park. Take Woodward car, get off at Adams Avenue.

ABSOLUTELY FIREPROOF

200 Rooms, Private Bath, \$1.50 Single, \$2.50 Up Double
200 " " " 2.00 " 3.00 " "
100 " " " 2.50 " 4.00 " "
100 " " " 3.00 to 5.00 " 4.50 " "

Total, 600 Outside Rooms

ALL ABSOLUTELY QUIET

Two Floors—Agents' Sample Rooms

New Unique Cafes and Cabaret Excellente

Bent Rims—Bent Rims—Bent Rims—Bent Rims—Bent Rims—

OAK AND HICKORY

BENT RIMS



of QUALITY

For Carriage, Wagon or Automobile
 Wheels

THE J. M. SKINNER BENDING COMPANY

TOLEDO - - - OHIO

One of the oldest and largest Rim Manufacturers in the
 U. S. A.

Bent Rims—Bent Rims—Bent Rims—Bent Rims—Bent Rims—

Please mention "The Hub" when you write.

New and Distinctive

High Grade Closed Auto Bodies of Aluminum



ANNOUNCEMENT!—The Bela Body Company, of Framingham, Mass. (recently organized under Massachusetts laws), have purchased one of the finest manufacturing plants in the east, and are completely equipping it for every detail of fine Automobile Body work.

OUR SPECIALTY—We specialize in High Grade Closed Bodies of new styles and types. Already a number of the large automobile manufacturers have had us design and build Special Fine Closed Bodies

OUR EXPERTS—Our Mr. Bela, the first man in the U. S. to use an Automatic Metal Bumping Machine, is recognized as the most expert Sheet Aluminum Worker in this country. Many of the best operators owe their success to his personal instruction. Each of the men associated with Mr. Bela is a master workman—all are experts in the various departments of body building.

LEADING MANUFACTURERS in the trade are turning to us for exclusive designs and strikingly distinctive high class bodies. They realize the sales value that such bodies give to their cars, for no one denies that

Bela Bodies Show "Class"

HIGH RECOGNITION—When the leading automobile manufacturers in the country buy bodies from us—comment is unnecessary. Note the Liberty Brougham shown above. The body of this stylish Town Car or Ladies' Shopping Brougham made an instant hit. It is causing more favorable comment and selling better than any other style body for years. It is unquestionably one of the lightest, strongest and most attractive bodies ever built. Observe its compactness, its clean cut graceful lines, its handsome appearance.

ONE-PIECE CONSTRUCTION—Particular attention is called to the fact that this unique body is made entirely of Aluminum, without any seams or belt line irons (belt line rolled in). Not a seam or a joint to open or crack. The roof, sides, back—everything being without seam. This construction eliminates much weight in the belt line irons and fasteners, as it does away with these entirely.

Our Paint Department, shown opposite, is the lightest and best in the country. Our Trimming Department is a model manufacturing building. The entire building is fire-proof.

LOCATION—On the main line of two railroads, within easy reach of Boston, New York, Springfield, Worcester and Providence, via state roads or railroad. When you want BODIES that will help SELL YOUR CARS—let us build them.

**THE BELA
BODY CO.,**
Framingham,
Mass., U. S. A.



ROME-TURNEY

units represent extremely advanced engineering. We have built radiators of all types for 14 years and are specialists in designs developed for truck construction. No better radiators can be built. If this were possible we would build them.

"RADIATOR INSURANCE"

SEAMLESS COPPER HELICAL
TUBE COOLING SECTIONS

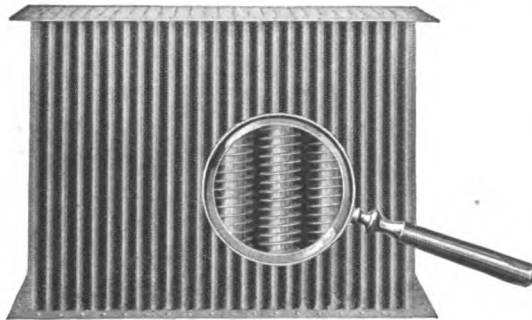

*Are Guaranteed for the Life of the
Motor on Which They are Installed*

*Helical Tube Construction is Accepted as the
Best by the Leading Truck Makers of America*

MANUFACTURED ONLY BY
ROME-TURNEY RADIATOR COMPANY
ROME, NEW YORK

When you install a
HELICAL TUBE RADIATOR
on your truck, you have the certainty
that the radiator will make good or we
will. We probably won't have to—
ROME-TURNEY RADIATORS
have a habit of making good them-
selves. But if the cooling section devel-
ops leaks, we will repair it free.

CLASSIFIED INDEX

For Addresses See Alphabetical Index
and Advertising Pages

AUTO FABRICS

Barrell, Wm. L., Co., New York
Keratol Co., The, Newark, N. J.
Laddlaw Co., Inc., The, New
York.
O'Bannon Corporation, New
York City.
Standard Oil Cloth Co., New
York City.

AXLES (Including Ball and Roller Bearing)

Sheldon Axle & Spring Co.,
Wilkes-Barre, Pa.

BODIES

Bela Body Co., Framingham,
Mass.

BOLTS AND NUTS

Columbus (O.) Bolt Works Co.
Russell, Burdall & Ward Bolt
& Nut Co., Port Chester, N.Y.

BOLT CLIPPERS

Porter, H. K., Everett, Mass.

BRAZING SLEEVES

White-Quehl Mfg. Co., Cincin-
nati, O.

BRONZE BEARINGS

Lumen Bearing Co., Buffalo.

DIE CASTINGS

Acme Die Casting Corp., Brook-
lyn, N. Y.

DIES

Bliss Co., E. W., Brooklyn, N.Y.
(Sheet Metal Working).

FORGINGS

Eccles, Richard, Auburn, N. Y.
(Carriage, Drop).
Williams, J. H., & Co. Brook-
lyn, N.Y. (Automobile, Drop)

FIFTH WHEELS

Millersburg Fifth Wheel Co.,
The, Millersburg, Pa.
Wilcox Mfg. Co., D., Mechanics-
burg, Pa.

HARDWARE (Carriage, Wagon and Automobile)

Columbus (O.) Bolt Works Co.
Dowler, Chas. L., Philadelphia.
Eccles Co., Richard, Auburn,
N. Y.
Wilcox Mfg. Co., D., Mechan-
icsburg, Pa.
Wing Co., Chas., Amesbury,
Mass.
Cowles, C., & Co., New Haven,
Conn.
Parsons Mfg. Co., Detroit, Mich

LEATHER SUBSTITUTES

Barrell Co., Wm. L., New York.
Keratol Co., The, Newark, N. J.
O'Bannon Corp., New York.
Standard Oil Cloth Co., New
York.
DuFont Fabrikoid Co., Wil-
mington, Del.

MACHINERY AND TOOLS

Bliss Co., E. W., Brooklyn, N.Y.
Pettingell Machine Co., Ames-
bury, Mass.
Smith, H. Collier, Detroit, Mich.
West Tire Setter Co., Roches-
ter, N. Y.
Williams, J. H., & Co., Brook-
lyn, N. Y.
White-Quehl Mfg. Co., Cincin-
nati, O.

MACHINERY (Metal Working)

Bliss Co., E. W., Brooklyn, N.Y.
Smith, H. Collier, Detroit, Mich

METAL STAMPINGS AND NOVELTIES

Murcott-Duden Co., Inc., New
York.
Pressed Steel Co. of New York,
New York City.

MOTORS

Brennan Motor Mfg. Co. Syra-
cuse, N. Y.

PATENTS

Jenner, H. W. T., Washington,
D. C.

PAINTS AND COLORS

Johnston Paint Co., R. F., Cin-
cinnati, O.
Pierce Co., F. O., New York.
Sherwin-Williams' Co., Cleve-
land, O.
Valentine & Company, 456 4th
Ave., New York; 343 S. Dear-
born St., Chicago; 74 Pearl
St., Boston.
Wiley Co., C. A., Hunter's
Point, N. Y.

PRESSES

Bliss Co., E. W., Brooklyn, N.Y.
(Drop, Power).

RADIATORS

Harrison Mfg. Co., Inc., The,
Lockport, N. Y.
Rome-Turney Co., Rome, N. Y.

SCHOOL FOR DRAUGHTS- MEN

Mechanics' Institute, New York

SHAFT COUPLINGS

Bradley & Son, C. C., Syracuse,
N. Y.
Eccles Co., Richard, Auburn,
N. Y.

SPRINGS

Mulholland Co., Dunkirk, N. Y.
Sheldon Axle & Spring Co.,
Wilkes-Barre, Pa.

TOOLS

Williams, J. H., & Co. Brook-
lyn, N. Y.

VARNISH AND JAPAN

Parrott Varnish Co., Bridgeport,
Conn.
Pierce Co., F. O., New York.
Sherwin-Williams' Co., Cleve-
land, O.
Valentine & Company, 456 4th
Ave., New York; 343 S. Dear-
born St., Chicago; 74 Pearl
St., Boston.
Wiley Co., C. A., Hunter's
Point, N. Y.

WHEELS

Bookwalter Wheel Co., Miami-
burg, O.
Crane & MacMahon, Inc., New
York City.
Hoopes Bros. & Darlington
Inc., West Chester, Pa.
Smith Wheel, Inc., [Metal],
Syracuse, N. Y.

WOOD BENDINGS, WHEEL STOCK, ETC.

Columbus (O.) Bending Co.
Crane & MacMahon, Inc., New
York City.
Skinner Bending Co., J. M.,
Toledo, O.

Please mention "The Hub" when you write



The Only
One-piece
Moulded
Leather Packing

The Bradley Carriage Coupler

All-Steel Noiseless Quick-Shifting Ball-Bearing

(MADE IN FIVE SIZES FOR
AXLES $\frac{1}{4}$ INCH TO $2\frac{1}{4}$ INCH)

The only carriage coupler that is
furnished with a ONE-PIECE
MOULDED LEATHER PACKING

C. C. BRADLEY & SON, Syracuse, N. Y.



The Bradley
Carriage Coupler

Vehicle Mechanics

Desiring to improve their present
Condition should attend the

TECHNICAL SCHOOL

For

Automobile Draftsmen and Mechanics

Supported by the

The National Automobile Chamber of Commerce, Inc.

The object of the School is to teach men to design
vehicles and make working drawings, and to otherwise
facilitate their work in the shop. Only those men em-
ployed in carriage or automobile building or their acces-
sory trades are admitted to its privileges.

The classes are conducted in three divisions, viz.: Cor-
responding, Day, and Evening. The former is open during
the entire year, while the day and evening classes are in
session only from October 1 to April 1.

The tuition is moderate.

For prospectus and full particulars, write to the instructor,

ANDREW F. JOHNSON,
20 West Forty-fourth St.,
NEW YORK CITY

THE BRUNSWICK



Boylston Street, Corner Clarendon,
(Facing Copley Square)

BOSTON - - MASS.

High class modern house, intelligent service,
pleasant rooms, superior cuisine.
Ladies traveling alone are assured courteous attention
European plan, single rooms, \$1.50 up; with bath,
\$2 up; double, \$2 up; with bath, \$3 up.
American plan, \$4 per day up.

FRED E. JONES - Proprietor

Results Always Follow
Advertising in
THE HUB

It Pays
Others
It Should
Pay You

RUSSELL, BURDSALL & WARD BOLT & NUT CO.

Established 1845

PORT CHESTER, N. Y.

MAKERS OF THE CELEBRATED EMPIRE BOLTS AND NUTS

Western Office: Continental & Commercial Bank Bldg., Chicago, Ill. Branch Works: Rock Falls, Ill.

Please mention "The Hub" when you write

BUSY BUYERS BRIEFS

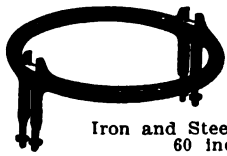

Manufacturers
**FIFTH
WHEELS**
All Varieties
Heavy Goods a
Specialty

Iron and Steel Rings from 4 to
60 inches wide
MILLERSBURG FIFTH WHEEL CO.
Millersburg, Pa.

WE MANUFACTURE
**FINE VEHICLE
WHEELS**
The Bookwalter Wheel Co.
MIAMISBURG, OHIO

**JOHNSTON'S
KRAKNO**
Color Card Free
\$3.50 per gallon
The R. F. Johnston Paint Co.
Cincinnati, Ohio

Why Not Have the Best?



One of a Large Variety

G. Cowles & Co.
NEW HAVEN,
CONN.

J. C. DECKER
MONTGOMERY, PA.
Manufacturer of
Carriage, Skate and Pad Straps
Side Loops, Bridle Fronts, Tail Ties, etc.

THE CHARLES WING CO.
Established 1848
Manufacturers and Wholesale Dealers in
**AUTOMOBILE AND CARRIAGE
HARDWARE AND TRIMMINGS**
AMESBURY, MASS., U. S. A.

CHARLES L. DOWLER

CARRIAGE AND WAGON HARDWARE
108 North Third St., Philadelphia, Pa.
CUSHION MANUFACTURER
Pure Stearic Acid Candles. Wheel Stock. Snow
Flake Axle Grease.

**MULHOLLAND
BUGGY SPRING**
Reduces weight of springs one-half.
Made in one size only but will fit bodies
of all widths.
Write for further particulars and prices.
THE MULHOLLAND CO. DUNKIRK, N. Y.

White's Brazing Sleeves
For applying Rubber Tires
Send for Samples.
WHITE-QUEHL MFG. CO.
431 E. Pearl St.
CINCINNATI, OHIO

Subscribe **THE HUB** \$2.00
Now for Per Year

**WILLEY'S
COLORS**

The Recognized Standard



C. A. WILLEY CO.
COLOR GRINDERS

and Manufacturers of Specialties in

**CARRIAGE, AUTOMOBILE and CAR
PAINTS**

COLORS, VARNISHES, ETC.

HUNTER'S POINT, NEW YORK CITY

**O'BANNON
ARTIFICIAL
LEATHER**

Reg. U. S. Pat. Off.

Moleskin Quality

The Best Leather Substitute

All the
Standard Leather Grains, Colors and Finishes
GUARANTEED

Against Cracking, Peeling or Wearing Down
to the Cloth Backing

WRITE FOR SAMPLES

O'BANNON CORPORATION
200 Fifth Avenue, New York City

HOOPES BRO. & DARLINGTON

(INCORPORATED)

WEST CHESTER, PA.

WE ARE MAKING

AUTOMOBILE WHEELS

Forty Years' Experience as WHEEL MAKERS is guarantee we can make good ones.
Will not make any other kind. Try them.

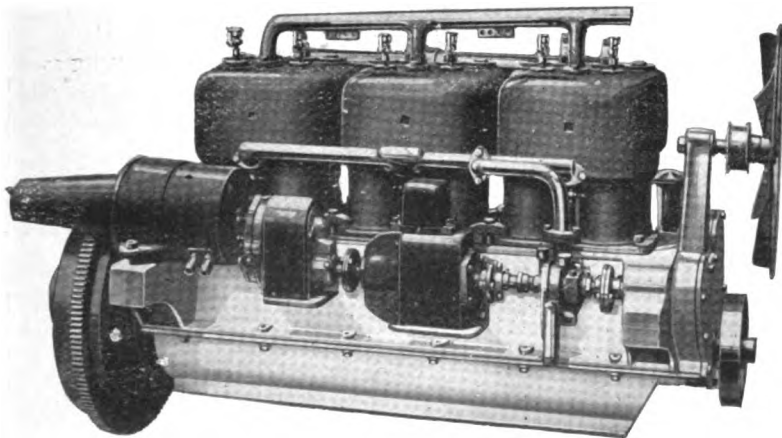

Model 6B Motor, 4 1/2" bore by 5" stroke

Quality and Service

are the two essentials that for 17 years have been built into

BRENNAN STANDARD MOTORS

The manufacturer of Commercial or Pleasure cars who equips his product with Brennan Standard Motors can feel assured his every requirement regarding this vital part has been fulfilled.

Built in the following sizes:

- 4 Cylinder Model M—4 x 5
- 4 Cylinder Model B—4 1/2 x 5
- 4 Cylinder Model 11—5 x 5
- 4 Cylinder Model 12—5 1/2 x 6
- 4 Cylinder Model 12—6 x 6
- 6 Cylinder Model 6B—4 1/2 x 5

Let us send bulletins telling WHY Brennan Motors are STANDARD motors

Brennan Motor Mfg. Co., Syracuse, N. Y.

WILCOX

FINE
FINISHED
FORGED

CARRIAGE HARDWARE
AND GEAR IRONS

Write for Prices and Catalog

The D. Wilcox Mfg. Co.

MECHANICSBURG, PA.

The WEST Hydraulic Tire Setter

WILL CUT DOWN EXPENSE

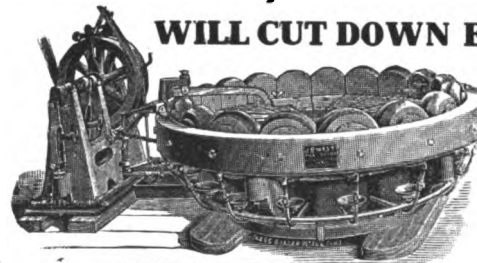

Tires set cold in one minute. This machine saves time—does the work better and quicker, does a way with burned streaks. Only necessary to measure one wheel in a lot. Does not char the rim, and

thus make the tire loosen prematurely. Saves rebandpapering of wheels. This machine is now increasing the profits of many manufacturers. Send for catalog and read about it.

WEST TIRE SETTER CO., ROCHESTER, NEW YORK

PORTER'S BOLT CLIPPERS

"Easy" "New Easy" Allen-Randall

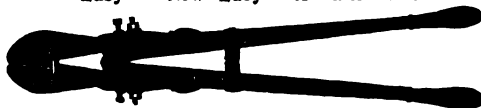

To Cut 5-16, 3-8, 1-2, 5-8, 3-4 Inch.

H. K. PORTER,

EVERETT, MASS.

"Quickwork"

Sheet Metal
Working Machinery

For Automobile and Carriage Bodies, Fenders, Hoods, etc.

H. COLLIER SMITH

807-815 SCOTTEN AVE.

DETROIT, MICH.



85-87 ADAMS ST.
BROOKLYN, N.Y.

We manufacture

FELT AUTOMOBILE WASHERS, GASKETS AND STRIPS

for every requirement.

FORD WASHERS AND GASKET SETS, "Rounds Brand"

for the jobbing trade

LET US QUOTE ON THAT RUSH ORDER

The Hub

AUTOTRUCK

Hickory Nut and

BEST QUALITY STOCK
TOUGH AND HEAVY
BONE DRY

MANUFACTURED BY
CAPABLE MECHANICS
AND MOST
IMPROVED MACHINERY

WHEELS WHICH ADD TO
THE LIFE OF YOUR TRUCK

ST. MARYS, OHIO

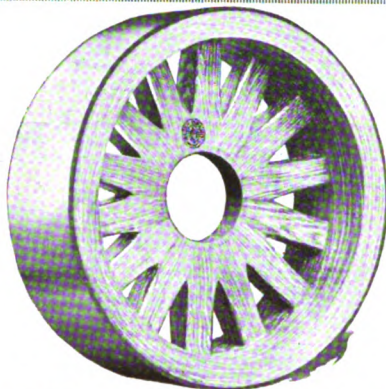

WHEELS

Acorn Brands

HORSE-DRAWN
VEHICLE WHEELS
ALL STYLES

TRAILER WHEELS:
SARVEN AND
ARTILLERY TYPES

HIGH STANDARD OF
QUALITY AND
WORKMANSHIP
MAINTAINED

8 BRIDGE ST., N. Y. CITY

CRANE & MacMAHON, Inc.

W. PIERCE CO.

NEW YORK,
U. S. A.

Manufacturers of High Class
Pigment Colors from ORIGINAL
FORMULAE. Colors ground in Japan
and other MEDIUMS to meet any
SYSTEM of APPLICATION.

We can now furnish Uzatona Reds ground in Japan, Oil or Varnish.
Prices upon application

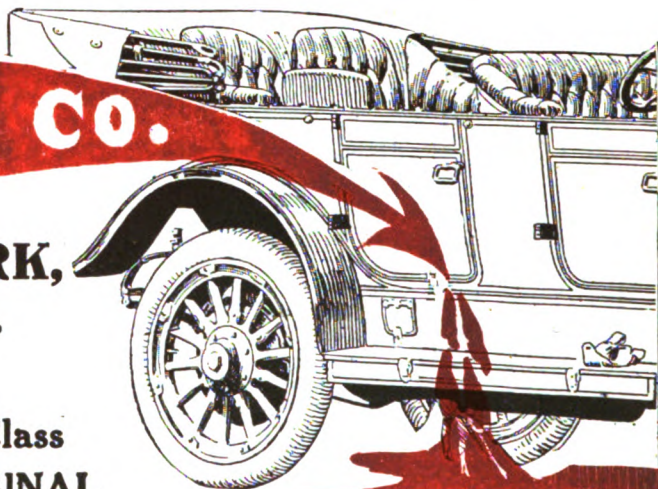

UZATONA
RED

Skewed Shaft Couplings

Regular or Oval Patterns
For High Arched Axles

Furnished in rights and lefts for any height of arch.
Oval Axle Clips $\frac{5}{8}$ or $\frac{3}{4}$ width to match Oval
Couplings. Bolts, Clips, Couplings, Carriage
Hardware and Special Forgings

Catalogue "H" and Prices on Application

COLUMBUS BOLT WORKS COMPANY

COLUMBUS, OHIO

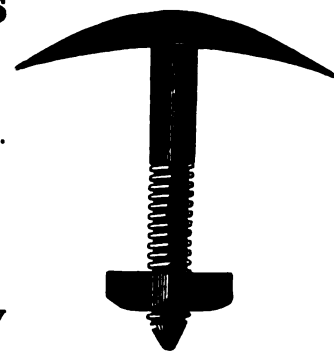
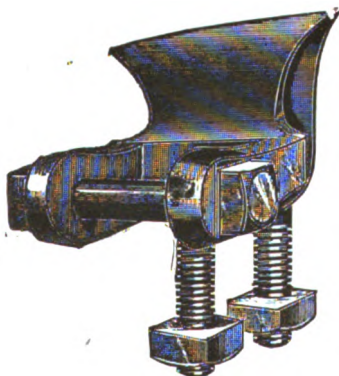

The Hub

First Journal of the Vehicle Industry

Vol. LVIII

NEW YORK, MARCH, 1917

No. 12

Front Axles
Worm Gear Axles

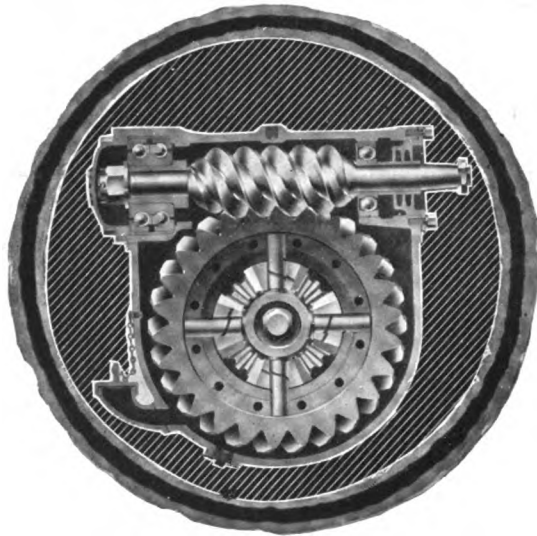

Motor Truck Springs
Pleasure Car Springs

Reduce Your Service Cost

Worm Gear Driven trucks require less attention than trucks using other types of drive

¶ Does the loss from your Service Department keep you awake nights?

¶ Is your Service Department a liability or an asset?

¶ While conditions are improving it is undoubtedly a fact that most service departments are liabilities.

¶ The surest way to transform the service department from a liability to an asset is to handle commodities which require little or no attention after they are turned over to your customers for operation.

¶ Worm Gear Driven axles not only are dependable, requiring little service because of their dependability, but in addition to this they are many times more durable than any other type of axle.

¶ In addition to the great length of life of worm gear axles it is also important to note that up to the point of absolute destruction, a worm gear grows more efficient with use, which is the direct opposite to the truth in the case of any other type of drive.

¶ This being true, it is obvious then that the dealer who handles worm gear driven trucks eliminates a big service problem that must be dealt with in any other type of drive.

¶ Therefore we say that one of the most certain ways of reducing your service costs is to handle worm gear driven trucks—preferably SHELDON WORM GEAR DRIVEN TRUCKS, but in any event worm gear driven trucks, for the worm gear type of drive has no equal from the standpoint of efficiency in all that efficiency implies.

¶ SHELDON WORM GEAR AXLES are of the semi-floating type with ball bearings carrying all worm loads. The driving strain is taken through the rear springs, thus eliminating all radius rods and torsion tubes with their added complications and weight. Both brakes are on the rear axle, doing away with the propeller shaft brake and its attendant excessive strains and wear on the rear assembly.

The Sheldon Axle and Spring Company

Manufacturers of Springs and Axles for More Than 50 Years

Wilkes-Barre

Pennsylvania

Digitized by Google

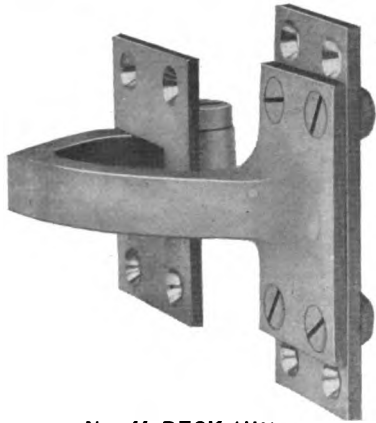

No. 44 DECK-HINGE
For Roadsters and Closed Bodies

Please note the extra body plate. Also the dowel which centers the machine screws, facilitating assembly of hinge to the body.

Another evidence of our system of improvements and suggestions on hardware articles.

We will manufacture high class hardware at less cost to you and give you prompt service.

Our No. 39 Concealed Hinge should be used on your touring bodies.



SEAMLESS TUBING STEEL—BRASS—COPPER

Send Us Your Specifications
for Rush Requirements

MURCOTT-DUDEN CO., Inc.

253 Broadway

New York



steel stampings

especially for
COMMERCIAL TRUCKS

The Pressed Steel Co. of N. Y.
141 Broadway

The Laidlaw Company Inc.

New York City

.....

**Automobile
Fabrics**

.....

**A Fabric for
Every Purpose
For Closed, Open or
Convertible Bodies**

A sure way to reduce your costs!

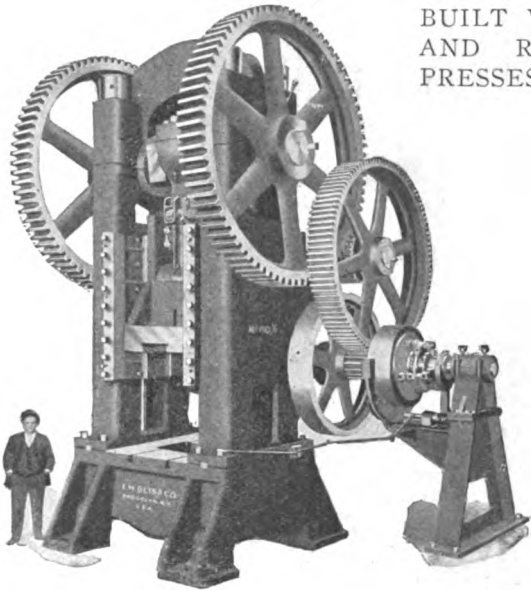

"Bliss" No. 80½ Straight Side Press
Weight, 175,000 Pounds

BUILT WITH THE GREATEST POSSIBLE STRENGTH AND RIGIDITY, BLISS STRAIGHT-SIDE POWER PRESSES MINIMIZE THE MAINTENANCE COST OF BOTH MACHINE AND TOOLS.

Bliss Straight-Side POWER PRESSES

are being widely used for heavy punching, piercing, shaping, stamping and drawing operations in the manufacture of automobile parts, agricultural implements, electrical instruments, cutlery and heavy hardware. They are also adapted for trimming drop forgings, hot or cold.

Built in various sizes ranging in weight from 5,000 to 175,000 pounds.

We are anxious to send you full details.

Let us know your requirements and we'll be glad to offer you a few valuable suggestions. Write us at once.

E. W. BLISS CO.

38 ADAMS ST., BROOKLYN, N. Y., U. S. A.

Chicago Office: Peoples Gas Building

Detroit Office: Dime Bank Building

Cleveland Office: Union Bank Building

Offices in Europe: 100 Boulevard Victor-Hugo, St. Ouen,
Paris; Pocock St., Blackfriars Road, London, S. E.



MACHINEBRONZE

CARRIED IN STOCK FOR YOUR CONVENIENCE
BY OUR DEALERS

CORED BARS

From ½ in. I. D. x 1 in. O. D. to 2½ I. D. x 4½ O. D. by ⅛ in.; 12 in. long.

SOLID BARS

From ½ in. dia. to 4½ in. dia. by ⅛ in.; 12 in. long.

MACHINEBRONZE IS MADE TO FORMULA ESTABLISHED SOME YEARS AGO AS A STANDARD FOR AUTOMOBILE AND MACHINERY CONSTRUCTION AND REPAIR AND IS RECOMMENDED AS THE BEST GENERAL PURPOSE BRONZE ON THE MARKET

Ask us for the name of the dealer in your city who can ship these sizes at once

LUMEN BEARING COMPANY, BUFFALO

Keratol LEATHER SKINS

For the car where leather has always been used



PRICE
Within Reason
QUALITY
Maintained

W^m L. BARRELL Co. 8 THOMAS ST.
NEW YORK



MOTOR QUALITY
FOR UPHOLSTERY



RAYNTITE
FOR AUTO TOPS

PREVALENT leather market conditions compel the adoption of a leather substitute for upholstering automobiles and carriages. FABRIKOID, Motor Quality, has established itself for upholstering requirements. It is pliant, strong and stands a greater strain than so-called "genuine leather" without tearing, and is positively waterproof.

FABRIKOID, Motor Quality, is continuously advertised in popular magazines and auto publications. Prospective owners of upholstered vehicles know the advantages of FABRIKOID, Motor Quality, upholstery over the so-called "genuine leather." Adopt FABRIKOID, Motor Quality, and solve the vehicle upholstery problem finally and satisfactorily.

TOP materials of light weight structure and guaranteed to be weatherproof are what are secured by the adoption of RAYNTITE.

Light weight tops meet the demands of the feminine autoist now entering the automobile field. Lightness of top combined with absolute protection and fine appearance makes a strong and convincing appeal to prospective purchasers.

Top your cars with RAYNTITE—the guaranteed, service-tested, light-weight topping material extensively advertised and demanded by those who know RAYNTITE'S merits. Top-makers should write at once for details of our co-operative advertising plans.

Samples of MOTOR QUALITY and RAYNTITE Showing Various Colors, Grains and Finishes Sent Promptly on Request

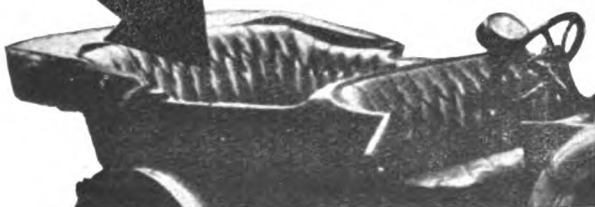

Du Pont Fabrikoid Co.

Wilmington, Del. Toronto, Ont.

FACTORIES: Newburgh, N.Y.
Elizabeth, N. J.
Fairfield, Conn.
Toronto



Please mention "The Hub" when you write.

MERITAS

LEATHER CLOTH

The Leading Leather Substitute

The best leather substitute naturally gives the best results in the finished product.

MERITAS LEATHER CLOTH is not a new, untried material—it has stood the test of time—it stands up well under the most severe service—holds its leather-like finish and gives complete satisfaction.

MERITAS LEATHER CLOTH is made in all weights, finishes, grains and colors for trimming purposes.

Get our samples to suit your particular requirements—write and tell us what grade and weight of goods you are in the market for.

Look for the trade-mark stamped on the back of every piece

The Standard Oil Cloth Company

INCORPORATED

320 Broadway

New York



A Tribute to Superiority



Within the short period of six weeks since the New York Automobile Show (and only three weeks after the Chicago Show) contracts have been closed with dealers for **MORE THAN ONE-QUARTER OF THE ENTIRE OUTPUT OF THE AMERICAN SIX FOR THE ENSUING YEAR.**

These contracts have been entered into with automobile merchants of standing and responsibility whose applications for the agency representation of the AMERICAN SIX are in themselves a marked tribute to the superiority of this uncommon car.

SPECIFICATIONS IN BRIEF:

Power Plant—45 H.P. 3 x 5 in. motor, cast en bloc, upper half crankcase aluminum, three-point suspension, water completely around each cylinder and each valve seat, helical gears, Zenith carbureter, Gray & Davis electrical system, Willard battery. Size of valves, 1 9/16 in. **Clutch**—Borg & Beck three dry-plate discs. Selective sliding gear, three speeds and reverse. **Axles**—front, one-piece drop forged I-beam; rear, three-quarter floating, spiral bevel gears, gear ratio 4 5/12 to 1. **Springs**—semi-elliptic, front 38 x 2 in., rear 52 x 2 in.; Hotchkiss drive. **Wheelbase**—122 in. **Tread**—56 in. **Wheels**—32 x 4 in. **Equi ment** includes engine-driven tire pump and motometer. All dash instruments are assembled on one plate, making a drivable chassis.

ANNOUNCEMENT

To Eastern Dealers—On account of the location of the American Motors plant at Plainfield, N. J., deliveries of the AMERICAN SIX to Eastern dealers are assured **REGARDLESS OF FREIGHT CONDITIONS.** Dealers in this territory who desire to ensure their supply of cars for the coming season are advised to communicate immediately with us.

AMERICAN MOTORS CORPORATION

Plainfield, New Jersey, and New York

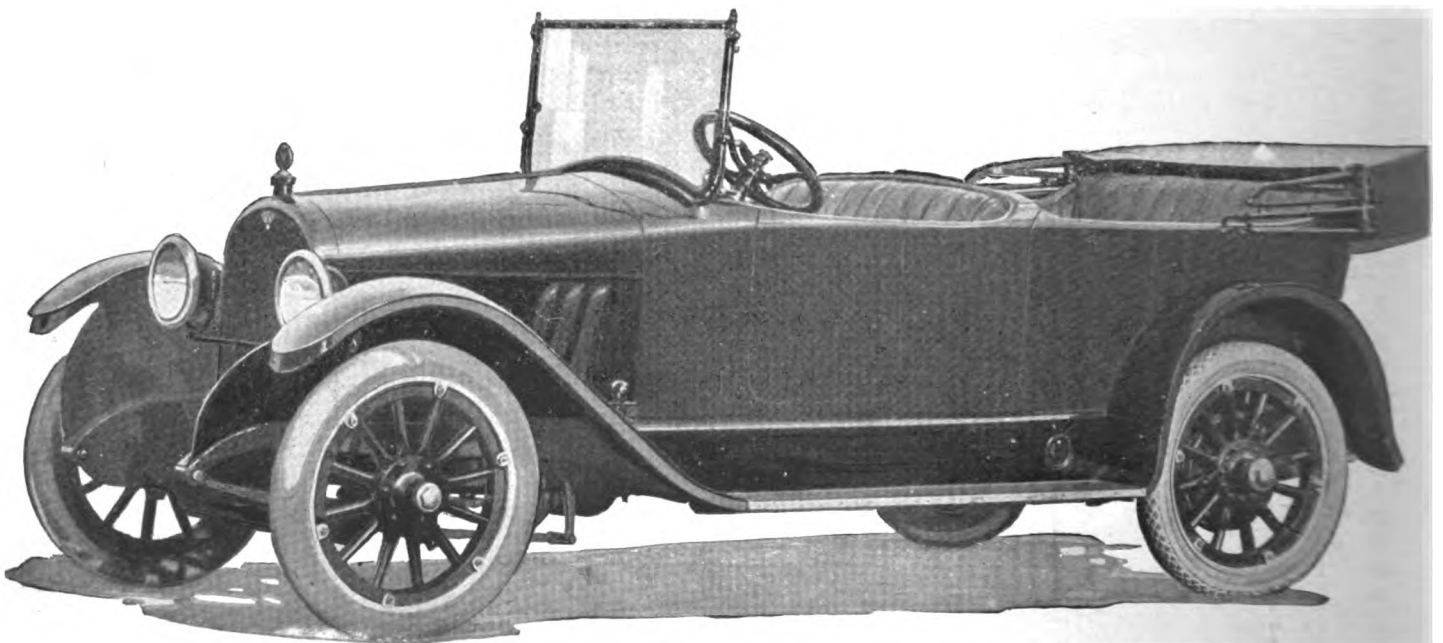

AMERICAN SIX \$1285

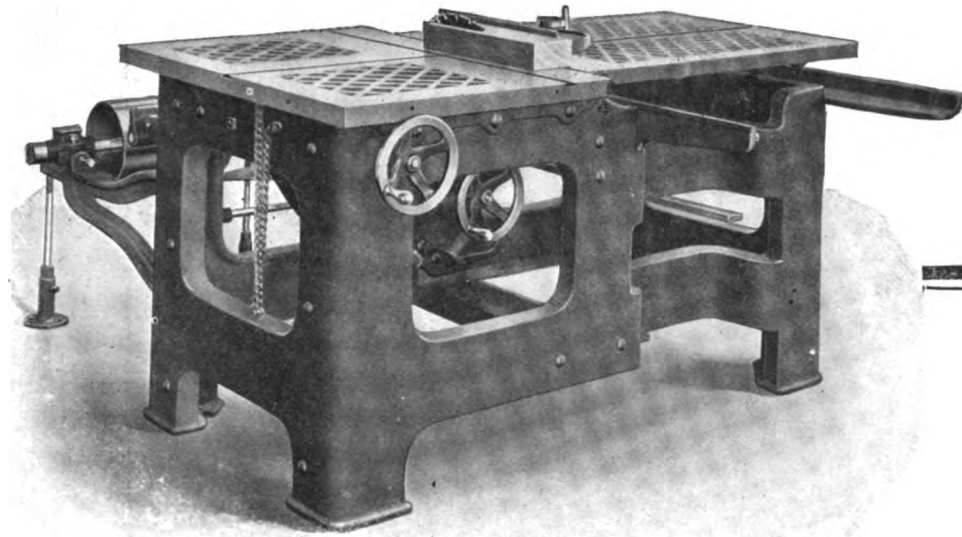

PETTINGELL

Extra Large Bevel and Mitre Saw Table

Heavy work requires a heavy machine. We have built this new machine *massive* and *heavy* and *rigid* to withstand the strain of modern Mill work. It *does* it—does even more—combines all the best ideas of our small Bevel and Mitre Saw with many new improvements, and practical features found *only on this machine*.

Frame work and entire construction are built to eliminate warping or twisting of tables or parts. This permits you to do *perfect duplicate work*. You can saw any bevel, mitre, angle or two angles *at once* and the work will be *accurate* to a dot. It saves time and labor, too.

Saw Can Be Raised or Lowered at Any Angle Up to 45 Degrees Without Stopping the Machine

The work is always level, it cannot bear down on either saws or gauges. Left-hand table can be quickly moved and adjusted as work requires, and the right-hand table can be easily moved to allow Dado heads in place of saw. The table runs very easily, being provided with special rolls and tracks.

It's the best Bevel and Mitre Saw Table in the world—installed in the largest and best factories in Detroit and middle west.

Sold on a guarantee of satisfaction.

A trial is all we ask—the machines do the rest.

Over 400 factories are now using our machines.

We will help you plan and install complete machinery equipment for any kind, style, quantity or output of work you need.

PETTINGELL MACHINE CO.

AMESBURY, MASSACHUSETTS

Williams' "Agrippa" Tool Holders

"THE HOLDERS THAT HOLD"



The Threading Tool Holder with Lockable-Spring Head does roughing, finishing and threading at one setting in the tool-post and uses cam-locked square cutter.

Their P.P.I.E. "Grand Prize" was only an incident. The satisfaction they are giving is what counts. Superior Drop Forgings for special purposes made to order.

J. H. WILLIAMS & CO.

THE WRENCH PEOPLE

44 RICHARDS STREET BROOKLYN, N.Y. CITY

SHERWIN-WILLIAMS VEHICLE FINISHES

A PRODUCT FOR EVERY PURPOSE, PRODUCING DISTINCTIVE RESULTS

S-W METAL PRIMERS S-W BODY AND GEAR UNDERCOATINGS

S-W Q. D. COLORS S-W COLOR VARNISHES

S-W FINISHING VARNISHES

EFFICIENT IN QUALITY AND UNIFORMITY

The Sherwin-Williams Co.

CLEVELAND

CHICAGO

NEWARK

MONTREAL

LONDON, ENG.



The Hub

Vol. LVIII

NEW YORK, MARCH, 1917

No. 12

Published Monthly by

THE TRADE NEWS PUBLISHING CO. OF N. Y.

PAUL MORSE RICHARDS, *President* G. A. TANNER, *Secretary and Treasurer*
EDISON BUILDING, COR. ELM AND DUANE STS., NEW YORK

THE HUB, a monthly authoritative journal on all subjects pertaining to the vehicle industry from its engineering and construction viewpoints. It publishes information of live interest to manufacturers of motor vehicles, trailers, carriages, wagons, the accessory trades, repair shops and garages.

Subscription price for the United States, Mexico, Cuba, Porto Rico, Guam, the Philippines, and the Hawaiian Islands, \$2.00; Canada, \$2.50; payable strictly in advance. Single copies, 25 cents. Remittances at risk of subscriber, unless by registered letter, or by draft, check, express or post-office order, payable to the order of THE TRADE NEWS PUBLISHING CO.

For advertising rates apply to the publishers. Advertisements must be acceptable to publishers. Copy for new advertisements must be received by the 25th of the preceding month. All communications must be accompanied by the full name and address of writer.

Entered in the New York Post Office as Second-class Matter

Importance of the Crops

At the moment no other factor in the national situation is of greater importance than intelligent, precautionary preparations to secure the largest possible acreage of land under cultivation, and particularly in the food crops, during the coming season. Whether we are to have war or peace, the population must be fed, and if, unfortunately, weather conditions should be unfavorable, and the yield no better than last year's, the food situation will be so much worse than it is now that we may well take alarm while there is yet time to provide against the possibility. The present crop year began with a large carry-over of all the grains, but it will end without reserves, and the whole world will be dependent upon the crops of 1917. The beginning is not good. The Argentine wheat crop, now harvested, is so nearly a failure that there will be little for export, and the corn crop will be not much better. The Australian wheat crop, which, like that of Argentine, is harvested in the months of our winter, is estimated at 139,392,000 bushels, against 187,120,000 last year, but fortunately there is a carry-over estimated at 80,000,000 bushels. A semi-official report puts the condition of French winter wheat at 65 per cent against 74 last year, and states that owing to the lack of fertilizer and want of proper preparation of the soil, the yield will be below normal. The crop of Holland is unpromising, and of England backward. In the United States there has been a shortage of moisture in the principal winter wheat states. The plant is not known to be injured, and there is yet time for sufficient moisture to come, but if it was under a snow covering the outcome would be better assured. A freeze has cut off the early vegetable crop in the southern states, which would have soon relieved the present scarcity.

In the Event of War

There is no reason to anticipate that a declaration of war by this country would have any immediate effect upon the business situation, other than that resulting from additional stimulus. The government has already entered the market for equipment and supplies, and is committed to great expenditures upon the army and navy, but doubtless its orders would be increased and expedited. The experience of other countries, and our own as well, shows that war makes enormous demands upon the industries, hence there would be no reason to apprehend a sudden reaction from the present activity. The danger would be from the other side, i. e., from an over-stimulus in certain directions at the expense of normal development. The industries of this country are already working to capacity, and it is difficult to see how they could do more. Under such conditions government orders would crowd private business to the rear, create new demands for labor and materials, and probably raise prices to a higher level. Enlistments would necessarily aggravate the scarcity of labor, and the amount of business in sight would be likely to stimulate further construction work for the enlargement of industries. These are the inevitable economic derangements caused by war, and in some degree we have already been experiencing their effects. War is not recommended by anyone who understands its economic effects as a means of increasing the wealth of a country, but if war must come it is certain that the United States is more fortunately situated to withstand it, and has greater resources with which to prosecute it than any of the countries which have sustained such marvelous exertions for now two and one-half years.

Use of Ponies and Carts in Chile

Native ponies are sometimes used to draw pleasure vehicles in the Valparaiso district of Chile, but no Shetland ponies are to be seen. The vehicles employed in driving the native animals are usually of the type of inclosed basket cart known in England as a governess cart. They are designed to be used with a horse weighing from 500 to 600 pounds.

These carts and other types of two-wheeled pleasure vehicles are imported principally from England. Carts made locally to be drawn by ponies or small horses are utility vehicles for distribution of milk, vegetables, etc.

The duty on carriages, carts, brakes, etc. (par. 1615, tariff of 1916), is 1 Chilean gold peso per kilo, gross weight (\$16.56 per 100 pounds, gross weight).

A list of houses in Chile which should be addressed by American exporters of pony vehicles may be obtained from the Bureau of Foreign and Domestic Commerce, its district or co-operative offices. Refer to file No. 81,773.

Analytical Study of 1917 Bodies

In a paper before the Detroit Section of the Society of Automotive Engineers, on February 16, J. Edward Schipper, technical editor of *Automobile*, summarized the results of an extensively close analytical study, not only of the automobiles at national shows, but also of the specifications and details of design characterizing 1917 cars of all American makes. That portion of his paper relating to bodies is as follows:

Bodies are not altogether satisfactory. There has been a great improvement during the year in the proportionment of space, particularly as regards the front compartment, but there are many instances where it must be said that the driver's seat is actually uncomfortable. In some the driver is quite comfortable after he has seated himself, but during the process of entering and leaving the seat he is a very uncomfortable individual. The point is that a large man physically may often buy a low-priced car and he is the last man to believe that the room in the driver's seat should be proportional to the price paid.

Naturally a longer wheelbase is to be expected on the higher price car, but with reasonable proportioning and care in working out the position of the pedals much can be accomplished. It was interesting to watch some of the taller individuals who were invited to sit in the cars by the ever-alert salesman. If the salesman were wise he would invite the more lengthy individuals to sit in the tonneau because there were several instances where the knees would come against the lower rim of the steering wheel. All in all, however, the situation, in this respect, is not so bad as it was a year ago. In fact there are a few cases where very good proportions exist in this respect and where one of the big selling arguments of the car was its driver's space. The driver is the owner in such a large proportion of the 3,000,000 cars on the road that he deserves considerable attention. He is the man that pays for the car, and should have as much comfort as his guests who occupy the tonneau.

A very high percentage of cars are sold by the body and therefore the designer should be afforded every opportunity to make the best job he can. This is being more appreciated every year. There was more variety in the bodies at the show this year than last. At that time practically everyone was striving for the molded form which may be said to approach the cylindrical. This year there are a number of prismatic designs in which the side line of the hood is left sharp and distinct. The effect of this variety is pleasing. Regardless of how we like a certain type of design, it is a psychological fact that we lose our appreciation for it if every other design is similar. Variety is stimulating and it must be said that this effect was much more notable this year than for several years in the past.

Great Variety of Color

From a superficial inspection of the color designs at the shows, the impression is gained that manufacturers are looking for other colors than black. The colors must be durable and that is the stumbling block of the brighter combinations. There are a number of grays and greens, however, this year and they afford a pleasant relief. Probably if the truth were known some of these other colors are not much more difficult to take care of than the more sombre black. At any rate it is noticeable that colors other than black are more numerous among the straight stock jobs than for some time in the past.

There is an increase in the number of four-passenger cars and a falling off or practical vanishing of the three-passenger cloverleaf type. The four-passenger cloverleaf of today is really not a cloverleaf at all, strictly speaking. If it were, the rear passengers would not have enough room. This was the objection last year and designers have given up the idea of cramping the rear passengers simply for the sake of having the body a true cloverleaf. The four-passenger roadster, which preserves the roadster lines with doors only at the front and with entrance to the rear through the aisle between the front seats, is very popular. There were a number of them at the show and they were always surrounded by groups.

While on the subject of bodies at the show a brief mention of the salon idea should be made. There is a class of purchasers who desire individuality in cars just the same as they do in clothing, shoes or in other lines. Some of the biggest dealers have increased their sales and their profits by putting custom-made bodies on stock chassis. The salons at New York and Chicago were well attended and the proportion of actual buyers to attendants is far higher than at the big national shows. In New York one rebuilt British chassis fitted with a fine example of the custom body builder's art sold off the floor of the Astor for \$14,000. This same idea carries back through all the price classes. On the street at New York, just outside of the Grand Central Palace, there was a row of cars fitted with some exceedingly neat speedster bodies painted attractive colors. These sold at an advanced price and although the chassis is one that is very low in price, these little cars with their attractive bodies appealed to a very high class of buyer.

Door Fitting Could Be Better

There is room for improvement in door fitting, according to an inspection of even the carefully prepared show bodies. On one side the doors would be tight and on the other, loose. The shape of the center cowl may also be improved and one car showed a real use for the center cowl by providing in it a place where the rear windshield could be housed when not in use. Many at the show believed that the rear windshield is coming and it has been said that once it is used, the user never wants to be without it.

Another place where improvement is suggested is in the contour of the upholstery of the back of the seat. After sitting in perhaps 50 or 60 different cars at the New York and Chicago shows, the different effects of the shape of the seat back cannot help but strike one as important. In some the bulge is too high, in others too low. In some it is necessary to sit exactly vertical and in others one actually leans forward if sitting well back in the seat. The most comfortable position seemed to be a slight backward lean with the bulge in the leather fitting the natural curve of the back. Care seems to be particularly necessary where the seat has a pronounced rake, as it is with these that the forward lean is imparted if the curve of the back is not correct.

The arrangement of the extra two seats on the seven-passenger car is better this year on some cars and not very good on others from the standpoint both of appearance and comfort. One maker folds his extra seats under the rear seat, giving perfect concealment. Another maker of four-cylinder cars has a particularly good arrangement with well-upholstered extra seats. These fold into a deep center cowl. One of the particularly good features about

them is that the backs are amply padded. A long ride in seats such as these is not the rather painful experience that it is on some of the hard seats without proper backs.

One last feature which needs only mention, as its practicability seems well realized, is the car for all times of the year. For the man who travels with his top up in summer, the permanent top type is supplied, and for those who like nothing but the blue sky overhead, are convertible types.

It seems fitting that a plea for better workmanship, particularly on bodies, should be made. The buyer of today looks into the matter of careful workmanship to a greater extent than is realized by many who deal with the manufacture of the car rather than its sale. The exterior outline has been given a great amount of attention, but just as in buying a house the purchaser looks not only at a beautiful exterior, but also at the fitting of the woodwork and at evidences of the care with which the trimming is applied. We have a firm foundation in the chassis, a beautiful piece of architecture in the body; now let us have fine workmanship in the interior.

In connection with the matter of body space, the distinct increase in the number of tilting steering wheels should be mentioned. One of the most difficult parts of body design is to observe all the correct proportions and at the same time allow of easy entrance into the driver's seat. The tilting steering wheel overcomes this problem very neatly, and one of the points upon which favorable comment may be made is in the increased number of these in use on the stock cars exhibited at the national shows.

Discussion

C. C. Hinkley: "Speaking of comfort, the average distance from the clutch pedal measured over the edge of the cushion to the seat back should lie between 37 and 38 in. on the average car. You can make it longer if you wish. If you make it short of 37 in. you will have what they call a slightly uncomfortable car. The shorter you get it the more uncomfortable it gets. The height of the seat does not enter into that; 13 or 14 in. falls within the limits of good practice. The height of the cushion from the floor can run from 13 to 15 in. The depth of the cushion can run from 16 to 18 in., 17 preferred. The distance from the under side of the wheel to the cushions can run between 7 and 8 in. The distance from the wheel to the seat back should be 13 to 15 in.; 15 is a little long, but you can get away with it. The width across the body at the point of the hip should not be under 42 in. and across the door; that is, along the front hinge, or where the door breaks, should be about 41 in.

"As for variety of color, I have had my fill of variety of color, and I want to say it is a bad proposition to go up against. It seems that people want color when color is scarce. That seems to be a human trait, and I want to say that you never get two lots of the same color alike.

"Regarding convertible cars, there is one thing I never could understand, why with the convertible we started out with, they began to take out the glass and the posts and left nothing but the roof. Now there is no more sense in taking out the posts, I believe, than there would be in putting five wheels on the car."

C. F. Jefferies: "Speaking of the number of special color show jobs. We all know that practically every show job is dolled up in some special color. In fact, I have known of a company to put all their show jobs in special colors, and they would not give the purchaser one for a \$50 bonus."

Mr. Stevens: "I think the color matter that Mr. Schipper referred to is really more a matter of factory practice and cost than it is an engineering matter, but the color matter is more serious probably than a great many of us realize. I have known of the time when a certain ingredient used in making red was so scarce that the entire market of the country afforded only 500 pounds and this was bid for by various color companies in the east and it shot the price up to a point where it was entirely out of proportion to the value.

"Another feature is, that in the modern system of baking which is very rapidly coming to the front on bodies as well as the metal or what was heretofore known as metal parts, the application of heat will change and alter to a great extent the shade of the color, and we have a Joseph's coat proposition all on one body, if they do not get a great amount of care all the way along the line.

"Another question is the fact that most of these bodies on the quantity production proposition are flushed or dipped with paint put on under pressure, a flooding process of various kinds, calling for a large amount of paint in the system. If the color should happen to change at the end of a season, there would be an immense loss in the paint on hand in the tanks. I really think the color matter is more nearly a factory matter than it is an engineering matter."

Mr. Schipper Replies

J. Edward Schipper (in response): "After the remark of Mr. Hinkley, to leave the posts remaining upright in the convertible body, I believe that it is not only the style, but it seems reasonable to do it. The great failure of the convertible type of body is the rattle that it develops, and the fewer movable parts you have in any body construction, the fewer rattles you are going to have. Not only that, if the posts were permanent, they could be made of smaller section than if they are removable because, like all removable parts, they are weaker if they are made in sections, they are weaker than they would be if they were permanent standards."

Gasoline From Oil Shales

In anticipation of the day when, on account of the advancing cost of gasoline and other products obtained from petroleum, it might be found commercially profitable to utilize some of the enormous supply of petroleum to be derived from the distillation of the vast deposits of so-called hydrocarbon shales of the Green River formation of northwestern Colorado and northeastern Utah, the U. S. Geological Survey has for three years been making field investigations of these deposits. The examinations have been accompanied by mapping of the areas of hydrocarbon shales and by such field measurements of the thickness of the shales in workable beds and such rude field distillation tests as will afford primary information concerning the amount and richness of the shales in different parts of the region.

Very rough but cautious calculations of the contents of the shale in parts of the area examined indicate that the distillation of shale from beds over three feet thick in Colorado alone will yield more than 20,000,000,000 barrels of crude oil, from which more than 2,000,000,000 barrels of gasoline can be extracted by ordinary methods. A report giving the results of these explorations and tests and an account of experiments as to possible gasoline production, both by the ordinary commercial processes and by the Rittman process, is now in press.

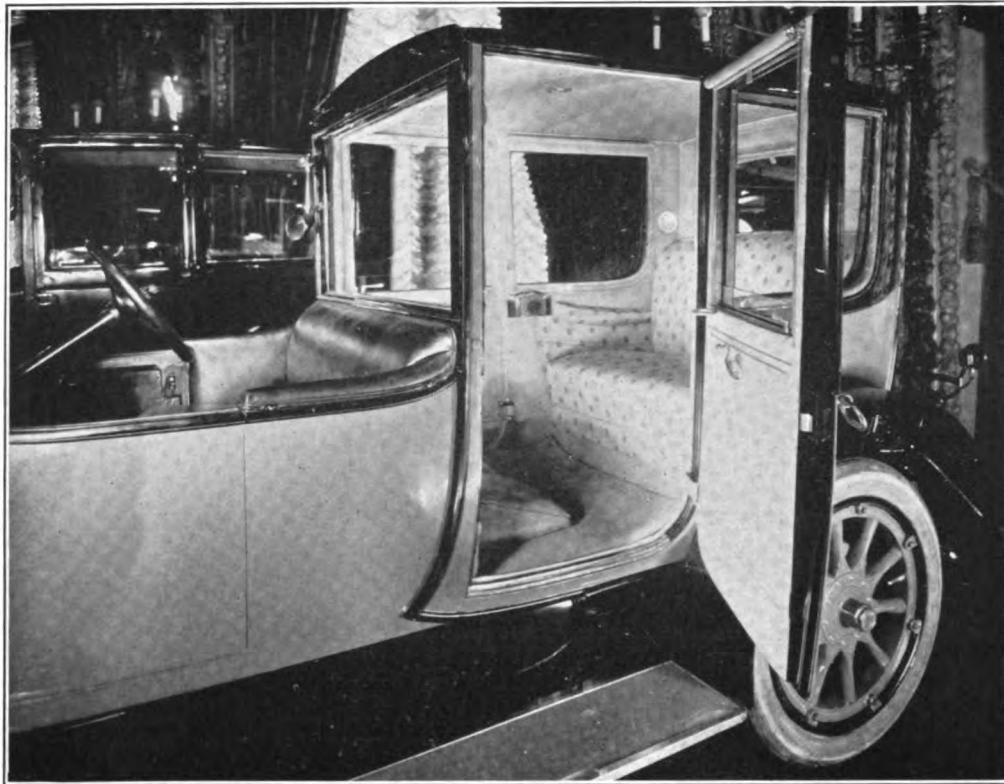

INTERIOR LANCIA SQUARE-CORNERED BROUGHAM
Body by Holbrook Co., New York

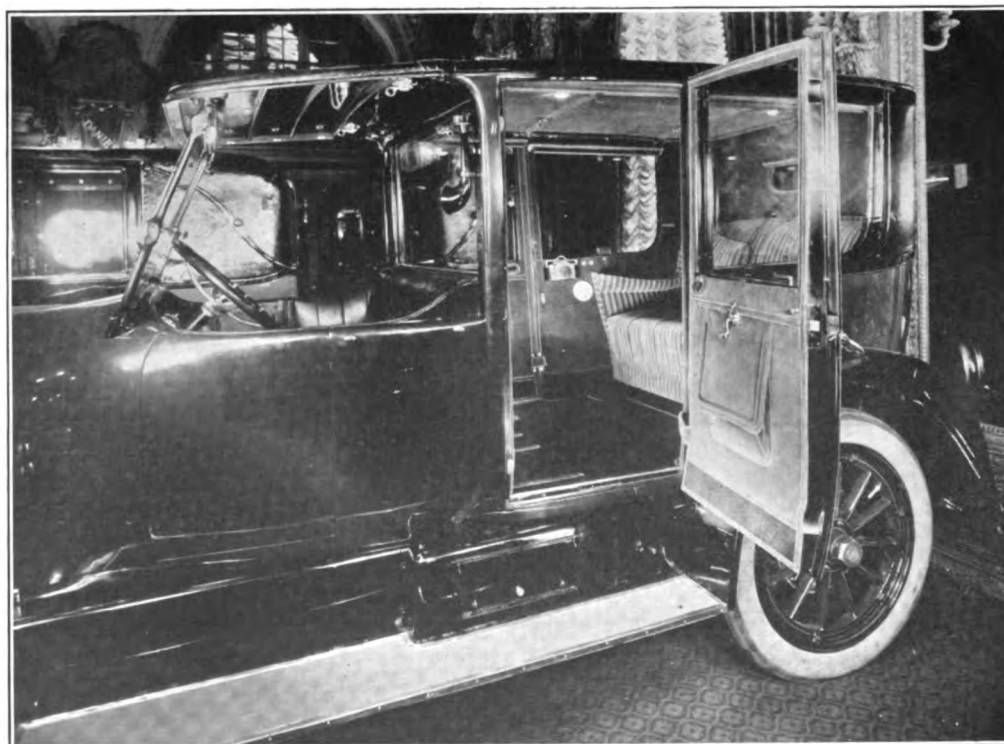

INTERIOR WHITE SEVEN-PASSENGER LANDAULET
Body by Holbrook Co., New York

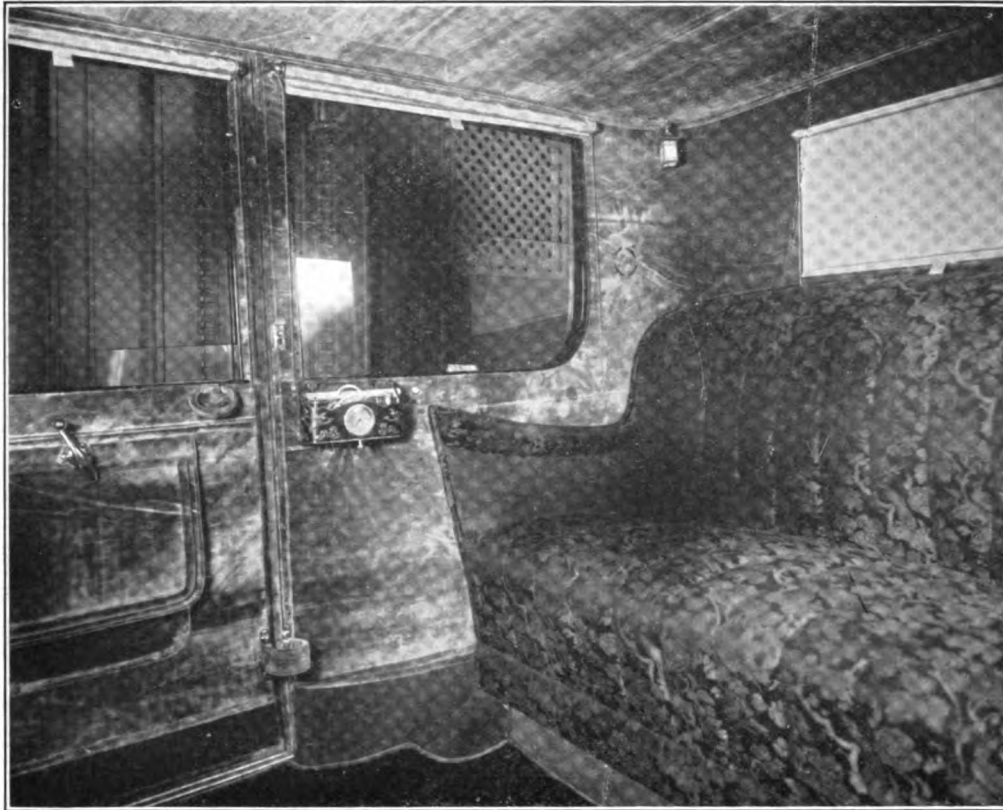

WHITE SEVEN-PASSENGER LIMOUSINE—CHINESE INTERIOR
Body by Holbrook Co., New York

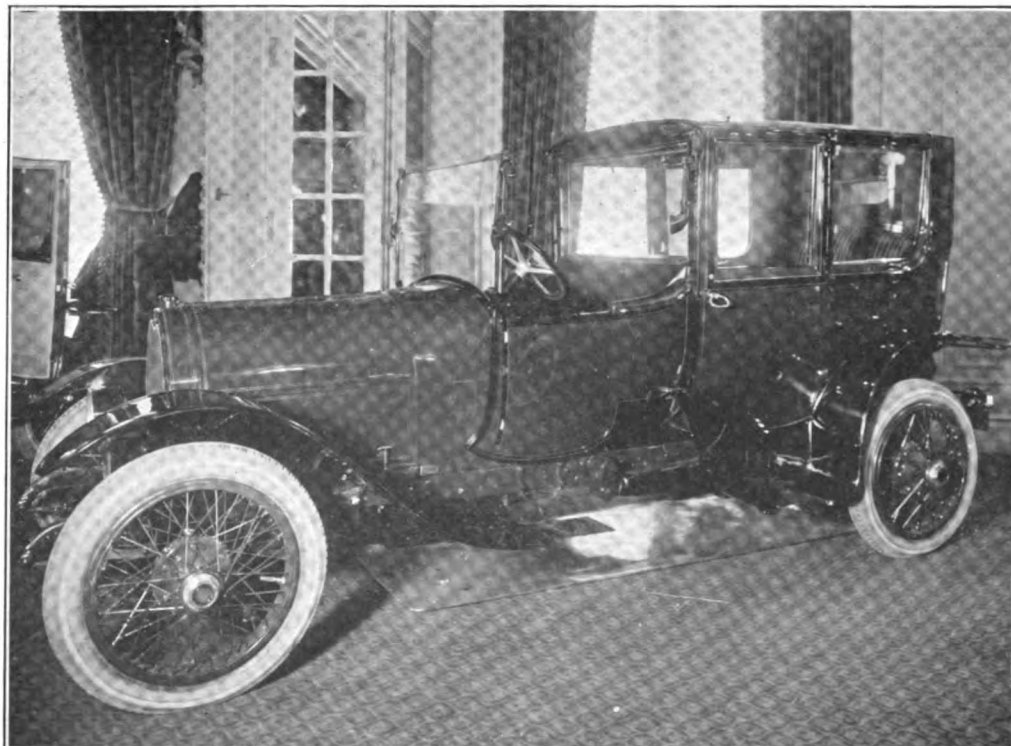

PHIANNA TOWN CAR
Body by Holbrook Co., New York

Description of Fashion Plates

Lancia Square-Cornered Brougham—Body by Holbrook

Painted special Holbrook blue, with black upper panels. Interior trimmed in special gray silk fabric, with designs in black in the Adam period. Inlaid Hungarian ash vanity cases, with silver and blue cloisonne fittings; moldings also Hungarian ash. Headlinings of plain gray silk to match background of seat upholstery. Car equipped with dictograph. Emergency concealed curtain over driver's seat.

White Seven-Passenger Limousine, Chinese Interior— Body by Holbrook

Painted black, with tan wheels and tan monogram panels. Seats upholstered in black and gold brocaded damask. Headlining gold colored silk velvet to harmonize Chinese rug, pagoda-shaped corner light. Carved and painted vanity cases of teakwood, with gold engine turned toilet articles. All moldings teakwood and all interior mountings gold. Equipped with dictograph.

White Seven-Passenger Landaulet—Body by Holbrook

Painted special Holbrook brown. Detachable solid roof over driver. Interior trimmed in striped mohair to match paint, with plain mohair headlining to match. Moldings and vanity cases of mahogany in antique finish. Fittings, silver and cloisonne. Car equipped with dictograph.

Phianna Town Car—Body by Holbrook

Painted special Holbrook blue to match interior upholstery. Concealed emergency curtain over driver. Upholstery blue striped mohair with plain headlining to match. Vanity cases inlaid mahogany in Adam period. Moldings mahogany, antique finish.

Truck Club Urges Tire Width as Basis for Tax

A significant fact in connection with the business prosperity of New York state during the past year is seen in the 1916 automobile figures recently compiled by Secretary of State Hugo. They show that the use of commercial motor vehicles increased 66 per cent over 1915. In other words, 34,653 commercial motor cars were employed by the farming, business, and traffic interests of the state during 1916, while in 1915 the number was 20,880. These figures are expressive of the increasing popularity and efficiency of the motor vehicle for a great variety of business uses, providing quick deliveries and permitting the producer of perishable goods to send his produce to a favorable market in much less time than was formerly the case.

The increasing use of these vehicles, coupled with the argument that they were unduly destructive of the highways, furnished the chief reason for the enactment of the new law by the legislature raising the tax on such vehicles from \$10 to \$70, according to the capacity load ranging from two to fourteen tons. Over the latter figure an additional tax of \$10 is imposed on each extra ton. The minimum rate of \$10 includes all commercial motor vehicles of from two to three ton capacity, including weight of the car with the load. This embraces all of the smaller 1,000-pound delivery vehicles and the three-quarter-ton trucks, which have increased very rapidly in use, not only in the larger cities but in the country districts and small towns. The tax of \$70 for the 13 to 14 ton vehicles means a payment this year of 14 times as much as formerly, embracing the regular seven-ton truck.

The weak point in the enactment of these large fees is that while ostensibly directed again road destruction the law took no account of the comparative road wear in difference of tire equipment. That important factor has been recognized by other states. In Massachusetts, for instance, the commercial motor vehicle fee is based upon a total weight of 800 pounds per inch of tire width, while Chicago makes a 1,000 pound weight per inch of tire width the basis for motor truck taxation. As the New York state law now stands, a narrow-tired vehicle pays no more than one of equal capacity but whose load is more equally distributed by wide tires.

The bill recently introduced into the legislature at Albany through the efforts of the National Automobile Chamber of Commerce, the Motor Truck Club of America, the New York State Motor Federation, and other bodies for the appointment of a new commission to make a scientific investigation into all of the facts concerning the use of commercial motor vehicles recognizes the reasonableness of a study of the load distribution.

"Homing" Motor Tires

The advent of the motor car in Australia has to a very considerable extent, as in other countries of vast distances and comparatively few traveling facilities, solved the difficulties of transportation. In many parts of the country the roads are merely bush tracks or overland stock routes, on which herds of cattle are driven long distances to the city markets or coastal freezing works.

The rough nature of the country over which the cars travel and the excessive heat often experienced have made the cost of rubber tires a serious item in maintenance, thereby causing many experiments to obtain a substitute for rubber at a moderate cost. The invention and recent perfection of the Australian "homing" tire is claimed to have solved the problem of producing an emergency tire at a comparatively small cost. Tests with tires made of various kinds of fiber were made, with the result that coir fiber was found to be the most suitable for the purpose because of its lightness, cheapness, resilience, and durability. The greatest difficulty was to discover a method of joining the ends of the rope to make a complete circle of the same size, but eventually a new splice was invented, and the tire as now sold in Australia is perfect of its type.

When first placed on the market the "homing" tire was sold as an emergency tire in case of a puncture or blow-out, but it proved so satisfactory that in the country districts of some of the states the rope tires are frequently used on all the wheels of motor cars, particularly for station or ranch work and over rough and stony country.

The tires are bullet, nail, and glass proof, and if a speed of 16 miles is not exceeded it is claimed that they are almost as soft riding as pneumatic tires. It should be understood that the "homing" tire takes the place of both inner tube and cover, being attached to the rim by four or five straps.

Carriage Makers' Club's New Officers

At the annual meeting of the Cincinnati Carriage Makers' Club, March 8, H. H. Nelson, of the American Carriage Co., was elected president, and the following manufacturers were chosen members of the board of governors: E. M. Galbraith, W. J. R. Alexander, W. H. McBride and E. E. Hess.

Carriage Builder's Art in Evidence

Luxurious Town Cars Embody Traditions of Horse Vehicle Days

By Merle Shepard

There is something fascinating about the luxurious closed body, even if it is not within reach of the average car buyer. This is one of the parts of the automobile builder's art which has been developed for some time; in fact, it can hardly be said that car bodies are more luxurious now than they were five years ago. They change, however, from time to time, in the same way in which styles of clothing, furnishings, or any other decorative work changes.

One of the most interesting chapters of automobile history is that which deals with the development of the present-day body. In these pages the trend of body design has been traced from time to time, and it has been shown how the body of today approaches the straight line form, whereas in the early days the scroll work and lines of beautiful curvature predominated. There are two distinct parts to an automobile. There is the chassis which embodies the mechanical development, including the gasoline power plant, the power transmitting means, and the framework which supports the car. The other part is the body, and it is this part which is interesting to every person who has anything to do with automobiles, because it is the part which meets the eye. Regardless of the mechanical refinement of a car, it is valueless as a sales proposition unless a well-designed body is carried upon the chassis.

Body Design Important

In the present day cars are bought to a very large extent because of the body design. Purchasers have come to realize that as far as mechanical refinement is concerned, there is not a very great difference between the different makes. Every company has had the opportunity of studying the development made by every other concern and, since there has not been any great change in the past few years, an opportunity has been afforded for every maker to catch up and bring his product up to date in the smallest details. In the early days this was not true. Progress and changes were made at such a rapid rate that certain makes of cars were far in advance of others, mechanically. Today this holds true to only a very small extent, and the companies which have been in existence for any length of time are producing cars of which the mechanical excellence can be taken for granted. Realizing this, whether consciously or unconsciously, the buyer naturally turns to the part which he can see. This is the body.

Dotted about the country are factories which in the by-gone days were employed by carriage builders. When the automobile began to attain prominence these carriage builders were divided into two classes. The first was the class which opposed the automobile and did everything possible to thwart its progress. The more progressive element among the carriage builders, realizing that the automobile industry, while young, was far more vigorous than the carriage building business, joined the ranks of the new industry and have, in a great many instances, become prominent manufacturers of either stock or custom bodies.

The carriage builder who opposed the automobile in-

dustry soon found that his trade was diminishing, and there are many deserted factories which have been sold to other interests which represent the last chapter in the history of some of the carriage builders. There are, of course, a great many builders of fancy horse carriages still in existence, but almost without exception these do a certain amount of automobile business also.

Carriage Builder's Opportunity

The carriage builder had his golden opportunity when the automobile business was young. The car of those days was the plaything of the man of wealth, and naturally no expense was spared to produce the best in body work to go along with the chassis. As will be remembered by all those who can recall the first of the automobile business, the coach builders of that day adapted their horse-drawn carriages to the motor vehicle, with the result that automobiles soon came to be known as horseless carriages, and the term exactly described them because they were nothing more or less than carriages mounted upon the motor-driven frame. The horse coach is a vehicle of curves and scroll work, and the first automobiles had the same type of body.

As time went on the influence of speed began to make itself felt. It is a psychological fact that the thought of speed in a man's mind immediately finds its interpretation in straight lines. The arrow is a symbol of speed. It is long and straight. The faster cars were made to travel, the longer and straighter they became. The car of 1917 is long, low, and has straight lines. The car of 1906 or 1907 was high, short and had curved lines. The law of wind resistance is one of the reasons for this change.

The automobile moving through the atmosphere can be compared directly with the motor boat moving through the water. The faster motor boats are long and narrow. They must be so in order to offer the least resistance in parting a way through the water. In the same way the automobile, which is intended to move along rapidly, must be designed so as to make its way through the air bank which resists it, with the least possible amount of resistance. The lines which the water takes as it opens before the motor boat and closes behind it are known as stream lines. In the same way the lines which it takes as it opens before the oncoming car and closes behind it are known as stream lines. Naturally, the body with the least possible resistance to air would have the same form as these lines and, consequently the type of body known as the stream line form was developed.

These stream lines or modifications of them are in use today in our bodies. They are most pronounced in the bodies intended for the highest speeds. We see, therefore, in racing cars that attempts are made to almost exactly reproduce the stream line. Curiously enough, the closing together of the air behind the car is of even more importance than breaking it at the front of the car.

The air cannot close abruptly behind the car because if it does so an air wave will be created which causes a suction and holds the car back. In the same way the stern of a motor boat is of importance because unless it is correctly formed, suction waves will be created behind the boat, which will hold it back. It is for this reason that behind the racing automobile we see a long pointed tail intended to allow the current of air to slip gently together without the creation of the suction which is so much dreaded by racing drivers.

Touring Cars Need Space

The matter of suction does not have to be so closely studied by the designer of touring cars. If high speed touring cars were the rule it would have to be, but as it is, only a modified streamline tail is necessary in the touring body, and hence we find that there is no great attempt made to close the lines in streamline form, as to do so would mean a sacrifice of space and passenger room, which is really of more importance at the speeds at which touring cars run than would be the streamlines.

Going a step further, we come to the closed car. It is only in a very small proportion of the closed car jobs that high speed is attempted. Therefore, speed is the least consideration and comfort the greatest in the designing of a closed car. Luxury of interior fitting and beauty of exterior design are the two great aims of the body designer. Here the same problem confronts the builder as was in existence in the times of the earliest horse-drawn vehicles. The question of exterior beauty and interior comfort was considered as carefully by the coach builder of 1890 as it is by the custom body builder of 1917. It is not to be wondered at, therefore, that the bodies of the closed cars more closely resemble the art work of the old carriage builders than anything else. In fact, it would be possible to name a score of the old and famous houses which catered to the desires of the wealthy in coach work who are now engaged in custom body building for the automobile buyer.

Luxurious Closed Cars

There are several types of these luxurious closed cars, and the form selected depends generally upon several factors, of which the most important are the following: First, does the owner drive himself or does he employ a driver? Second, the number of passengers to be carried. Third, is it desirable to have the vehicle permanently closed or is it intended also for afternoon use when it is desirable to lower the top to drive under the open sky when weather permits?

If the owner himself drives, he naturally desires to be one of the party occupying the car and not shut off from them by an intervening glass pane. Therefore, the sedan and coupe are quite common for this class of service. The sedan is nothing more than a closed or permanent top touring car. The coupe is a closed or permanent top roadster. Owing to the fact that the top is permanent, however, it can be lined and fitted quite luxuriously with dome lights and other conveniences. In the town bodies, such as the landau, a more formal vehicle is had. It is used less for touring purposes and more for carrying parties to the theatre or operas. The landaulet is an adaptation of the landau which permits of the top to be lowered in fine weather, allowing the passengers to have the open air if they so desire. The coupelet corresponds to the coupe in the same way as the landaulet corresponds to the landau; that is, the top can be opened when desired.

Fine Finish Essential

Naturally, on these fine closed bodies the greatest care is used in exterior finish, as well as interior upholstery. On the exterior, as many as 40 coats of paint are used to secure the rich luster desired in vehicles of this class. In the interior, fine cords, mohairs and other expensive fabrics are used for upholstery purposes. At some of the recent shows some very striking upholstery in pigskin was shown. There is no limit, in fact, to the amount of money

which can be spent in making these vehicles the last word in luxury. It is quite possible to put a \$5,000 body on a \$1,000 chassis, whereas in stock cars the proportion of body cost to the cost of the entire vehicle is so low that it seems impossible to believe.

It must be said that the work of the custom body builder is increasing year by year. People are demanding individuality in their cars to a greater extent than ever before. They may purchase a chassis which has become standard and of proved worth, and upon it fit a body which will be just as distinctive as anything could be which is manufactured to suit the individual taste of the buyer. This movement for individuality in bodies is a healthy one and encourages the art side of the industry. The more cars which are made in this way the more variety we will have and the brighter will be the appearance of our city streets.—N. Y. American.

Getting in Shape for C. B. N. A. Convention

Although the 45th annual convention of the Carriage Builders' National Association is six months in the future, the directors and committees of the association are hard at work with the preliminary work of making the convention a pronounced success. Already two-thirds of the exhibit space has been sold.

The convention and exhibition headquarters will be on the 19th floor of the Hotel LaSalle, Chicago, where the facilities are said to be better than obtained at the Hotel Gibson in Cincinnati last year.

The entertainment committee recently held a meeting in Chicago and formulated some innovations for the convention. The committee is made up as follows: Geo. B. Ogan, chairman, L. C. Chase & Co., Chicago; W. C. Martin, Illinois Iron & Bolt Co., Carpentersville, Ill.; Oscar Rosenberg, Standard Varnish Co., Chicago; Harry B. Staver, Staver Carriage Co., Chicago; J. H. Rowan, vehicle department, Montgomery, Ward & Co., Chicago.; E. J. Baker, Farm Implement News, Chicago; Fred A. Hastings, Republic Rubber Co., Chicago.

Brown-Lipe-Chapin Not in United Motors

With the decision not to exercise the option to acquire the factory and business of the Brown-Lipe-Chapin Co., by the United Motors Corp., negotiations between these two concerns have been abandoned. This means that the United Motors Corp. in no way whatever will be connected with the affairs of the Brown-Lipe-Chapin Co., manufacturers of differentials, Syracuse, N. Y. While it was the impression among the automobile trade that the Brown-Lipe-Chapin Co. had actually been acquired by the United Motors Corp., as a matter of fact the negotiations had never progressed beyond the point of an option to purchase the Brown-Lipe-Chapin Co.

Wapakoneta Wheel Co. Buys P. & D. Machinery

The New Wapakoneta (O.) Wheel Co. purchased the machinery of The Pinneo & Daniels Co., Dayton, O., also their supply of spokes and Norway iron, for the manufacture of P. & D. compressed band hub and tenon wheel.

The Pinneo & Daniels Co. have quit the manufacture of horse-drawn vehicle wheels to enable them to devote all their time and attention to the manufacture of wire automobile wheels.

Best Export Methods

By L. V. Hummel*

The subject of packing, marking and forwarding freight is such a large one that I will only touch on a few of the more salient features. A discussion on these subjects is also necessarily curtailed by the constantly changing conditions that are at present met in the shipping world.

Packing—In packing freight for export the importance of properly doing so is self-evident, and at present the American automobile manufacturer appreciates this, although in the past he did not, or, if he did, paid no attention to it.

There are some small matters which are still being overlooked. For instance, I have known claims made on cases arriving at foreign destinations for the goods contained therein being in a damaged condition or parts missing, but investigation developed that when the machinery was packed at the factory nuts were put on with a half-turn instead of being properly tightened. The railroad transportation, trucking through New York and handling on shipboard resulted in these loose nuts being shaken off and the bolts which they held dropping out. These bolts and nuts were overlooked when the goods reached destination; consequently a claim was presented.

Importance of Smaller Packages

There is one feature in regard to packing, other than properly doing it, which is not receiving the attention that it should, and that is the importance of reducing the size of the packages. Nearly every shipment of automobiles and parts pays ocean freight on measurement basis, and not by weight, and the slightest increase in the size of any box or crate means additional freight charges. A shipment of 50 automobiles recently handled that should have been so boxed that each automobile would measure 475 cu. ft., through an error in boxing, measured 5 ft. 1 in. in height instead of 5 ft. This seemingly slight error resulted in an increased freight payment of 10 tons on 50 automobiles, or \$300.

Marking—I cannot too strongly impress the necessity of following to the letter the instructions in regard to markings on export orders. Conditions in foreign countries demand certain markings with which the parties placing the order are familiar and whose instructions are reflected in the wording of the order. Many may seem to be useless and unnecessary to us, but they are all required by someone and have their part to play. The marks on bills of lading, consular invoices, etc., must correspond with the marks on the package, and whenever a discrepancy occurs the shipment is held up until the error is rectified. Consignees are not only put to a great deal of trouble, but in some cases become liable to fines as a result of a variation in marks.

A case has come to notice where goods have remained on dock for several weeks before the discrepancies in marks on documents and packages could be straightened out. This not only resulted in goods not being paid for promptly, but placed the shippers in a bad light with their clients. With cable tolls at 50 to 75 cents a word in many cases, the cables necessary to straighten out the tangle involved is an expense that must not be lost sight of.

Many mistakes occur which seem to be inexcusable.

*Traffic manager, Gaston, Williams & Wigmore. Digest of paper read at the convention of automobile export men recently conducted by the National Automobile Chamber of Commerce.

A case came to my attention of a carload shipment of spare parts where the invoice and packing list were received from the factory and corresponded with the instructions on the order, but when the boxes were received it was found that the marks on the boxes were intended for another order. This, fortunately, was discovered before the goods were delivered to the pier; but it was necessary to re-mark in New York 250 cases, which resulted in missing the steamer for which the cases were originally intended. There is only one thing for the manufacturer to do, and that is for him to rigidly follow the instructions received with the order.

Strict Routing Rules Impossible

Forwarding—As mentioned, it is practically out of the question today to lay down any strict rules as to how shipments should be routed, with so many shipping restrictions, trade embargoes, etc., existing throughout the entire world.

For example: In order to make a shipment to Russia it is necessary for the consignee to secure permit from the Russian officials in Russia for the goods to enter the country. In applying for this permit it is necessary to give a complete history of the article and the use for which it is intended. If the explanation is satisfactory the Russian officials issue a permit and their representative in New York is notified by cable.

Practically the same principle, with some slight modifications, holds good for England and for certain commodities in France. Trucks can only be shipped to France when they weigh 5,500 lbs. or over. This means that a certain class of trucks must be equipped with bodies in order to bring them up to the weight standard necessary for them to enter France.

Frequent Regulation Changes

The regulations covering the issuing of permits and the instructions as to marking packages change from day to day, and for this reason it seems desirable for the manufacturer to handle his export business through a forwarding agency or some similar concern fully equipped to look after such matters. The forwarding agent acts as the direct representative of the manufacturer; he is on the ground, is fully posted as to changes and regulations as they are made, and is in position to take advantage of any changes or fluctuations in ocean rates, such as may be afforded by a steamer being short of cargo and offering its remaining space at less than the current market rates. It is the business of the forwarding agent to watch for just such a case and give his client the advantage of it. He is also conversant with the requirements of every country and can furnish all documents, such as ocean bills of lading, consular invoices, export declarations, etc.

It would be necessary for a manufacturer located at some inland point to conduct negotiations, if he did not have a forwarding agent, either by mail or telegraph, or else maintain a representative of his traffic department at shipping point. Even though he decided on the latter, his shipments do not always pass out by the same port, and the forwarding agent who has his representative at all ports of consequence is better prepared to handle the shipments of his clients through all ports with better satisfaction than the manufacturer could.

Routes—I am afraid that it is impossible to give any definite information as to the most advantageous routes, for the simple reason that what may be the best today

would not be tomorrow, or might be entirely discontinued the next day. A steamship line sailing, for instance, under a belligerent flag may be forced to suspend its sailings at any time, due to the government requisitioning the vessel or vessels. Shipping at the present time is an hour-to-hour proposition.

Recently a permit was obtained for a shipment of 200 automobiles for Russia, but when it came time to ship it was found that they could only be accepted via the west coast, via certain railroads and via a certain ship. Elaborate plans had been made for forwarding via other routes but by an overnight decision these plans were upset and others had to be made; and it was necessary to forward some of these automobiles from the east, paying a railroad rate of \$2.25 per 100 lbs. as against a 48-cent rate to New York, and all this notwithstanding the fact that there were boats loading at New York.

This case is cited in order to show how conditions change overnight, and in this connection I desire to impress upon you again the importance of the manufacturer doing his part by seeing that the packing, boxing and marking are properly done so that when permits for ocean space are received the shipment is not further delayed due to the necessity of re-coopering, changing marks or discrepancies in measurement. In other words, a manufacturer before a shipment goes forward should be absolutely certain that he has followed all instructions received with the order.

Annual Tour of Tanning Students

On Sunday evening, April 1, the students of the tanning and applied leather chemistry courses at Pratt Institute, Brooklyn, accompanied by their instructors, will start on their annual tour of inspection. The first tannery to be visited will be that of Zellers' Sons, Buffalo, on Monday, April 2. After visiting the tannery on that day, it is expected that sufficient time will be at the disposal of the party for a side excursion to Niagara Falls. At 7:30 that evening the train will be taken to Olean, where reservations have been provided at the Olean House.

Tuesday morning will find the party at the Cattaraugus Tanning Co., Tuesday afternoon will be spent in Portville visiting the plant of the Northwestern Leather Co. Tuesday night will be spent in the train from Olean to Mercersburg, where one of the plants of W. D. Byron & Sons Co. will be inspected. Arrangements have been made by the company for the afternoon to take the boys in automobiles to the battlefield of Gettysburg.

Wednesday evening the party will go to Philadelphia where they will be entertained at the Continental Hotel. Thursday will be spent at the Dreuding tannery and the wool-pulling establishment of D. Strauss & Co. Thursday afternoon will be spent in taking in the sights of historic Philadelphia. Friday morning, the goat-skin tannery of Duncan, Hood & Co. will end the program, and Friday afternoon the trip will be made back to New York.

Packard Planning Huge Auditorium

The Packard Motor Car Co., Detroit, Mich., is planning the erection of a new sales and service building in Detroit, which will contain a huge auditorium with seating capacity for 2,500 persons. The building, which will be eight stories, will be erected on a lot 236 x 200 ft., located close to the junction of two of the city's principal arteries of travel.

The directors of the Packard company in planning the auditorium were influenced by the fact that Detroit, despite the important position it now occupies among the great centers of the United States, has no adequate building for the presentation of high class musical productions, a grand opera and other entertainments. As the company has developed to be one of the foremost industries of the city, it was deemed reasonable that it should demonstrate its loyalty to the citizens by contributing to their entertainment and pleasure. The work on the new building will start in June.

Studebaker South Bend Plant Extension

Extensions to the existing facilities of the Studebaker plant at South Bend, Ind., are being made by the erection of two large buildings to serve as a forge shop and machine shop respectively. While the Studebaker business as a whole has increased 200 per cent since 1913, plant expenditures, including the present extension, have only increased about 15 per cent. All the company's various works, therefore, are at present operating under extraordinary high pressure. Since 1913 castings, springs and bodies have been manufactured at South Bend, where the headquarters of the corporation are, and to which were recently removed the sales and advertising departments of the automobile division. The executive offices of the manufacturing department, in charge of Vice-president James G. Heaslet, however, remain in Detroit.

Tungsten Prices Recede

Tungsten has dropped in price from \$87.50 per "unit" to \$18, and is expected eventually to reach its normal price around \$7 per unit or \$420 a ton. Shortly after the war began it leaped upward because most of the supplies had been coming from Germany. Since then new sources of supply have been developed, and this, with a falling in demand as the most pressing of war needs were satisfied, has operated to bring the price down, almost as quickly as it went up.

Goodrich Annual Truck Manual

The B. F. Goodrich Co., Akron, O., has issued the fifth annual edition of "Motor Trucks of America," which is a comprehensive catalog containing brief specifications and illustrations of many of the motor trucks manufactured in this country. Information of the maintenance and repair of power vehicles is also contained in the book, together with much other valuable data.

In the Limelight—In a New Guise

Judging from recent reports, Henry Ford is emphatically

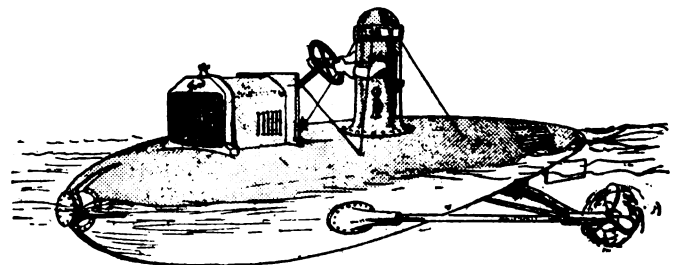

against war—unless America is involved—when he would enter into it on a quantity basis.—Light Car [London].

Nash Motors Company Foundry at Kenosha



There are intervals, usually at the inception of a business or immediately preceding some stages of expansion, when attention focuses on the building and its equipment, almost to the exclusion, temporarily, of the consideration of commercial and operating problems. This is so, primarily, because of the fundamental importance of both building and equipment. Secondly, it is so because much of the self-advertising of an enterprise center about the building and the equipment. It is an essential to subsequent satisfaction and operating economy that well crystallized ideas of what will best serve a business in the matter of fixed plant be had. The following description of a new gray iron foundry, just completed for the Nash Motors Company, Kenosha, Wis., presents a design and construction representative of what an unrestricted, engineering survey of the problem of producing from 50 to 70 tons per day of automobile castings would provide for that purpose.

The foundry was contracted for by the Thomas B. Jeffery Company and was nearly completed at the time ownership was transferred to the Nash Motors Company. The general scheme of the job was formulated in the endeavor to eliminate manual operations in the handling of all materials, to provide exceptional lighting, ventilating and sanitary conditions and to incorporate into the construction of the building an enduring character.

The building is a steel and concrete structure 620 ft. long and 120 ft. wide, extending from east to west. The longitudinal walls are of reinforced concrete with pilasters 20 ft. on centers, 4 ft. wide, having footings of reinforced concrete proportioned for an earth load of 35 lbs. per sq. ft. The fact that the soil at a depth of 8 ft. below the surface develops into quicksand necessitates keeping these

footings as near as possible to the surface and they were only carried down slightly over 4 ft. or sufficient to get below frost line. Between the pilasters, spandrel walls of reinforced concrete, 16 in. thick, extend to a height of 4½ ft. above the floor line. The entire space between the pilasters and extending from the top to the spandrel walls to the lower chord of the roof trusses, a distance of 22 ft. above the floor line, is hung with steel sash and glazed with ribbed glass. The west wall is of a temporary nature designed so that a future extension of 140 ft. may be made to the building at minimum expense; and it is of asbestos protected corrugated steel, supported by steel framework. The roof trusses are of steel supported at the outer walls by the pilasters and along the center line of the building by a single row of steel columns. The roof is of the improved monitor type, illustrated in Fig. 2, covered with cement tile and having monitor sash which, divided, into six sections, extends the entire length of the building on both sides and is motor operated.

The general layout of the building is illustrated in Fig. 1. The main entrance is in the center of the east end protected by a rolling steel shutter door. Through this an extension of the works' main side track from the east enters the building and passing across the northeast corner emerges on the north side and extends along that side to the west end, furnishes a means of bringing in coke, sand and iron to the storage yard. This track is a means also of conveying castings from the cleaning rooms to the plant machine shops located some distance east of the foundry.

Special attention has been paid to providing adequate light and means of ventilation. To this end, the entire side and the end of the building with exception of the pilasters is glass inclosed, and the monitor roof is pro-

This article and illustrations reproduced through the courtesy of The Iron Age.

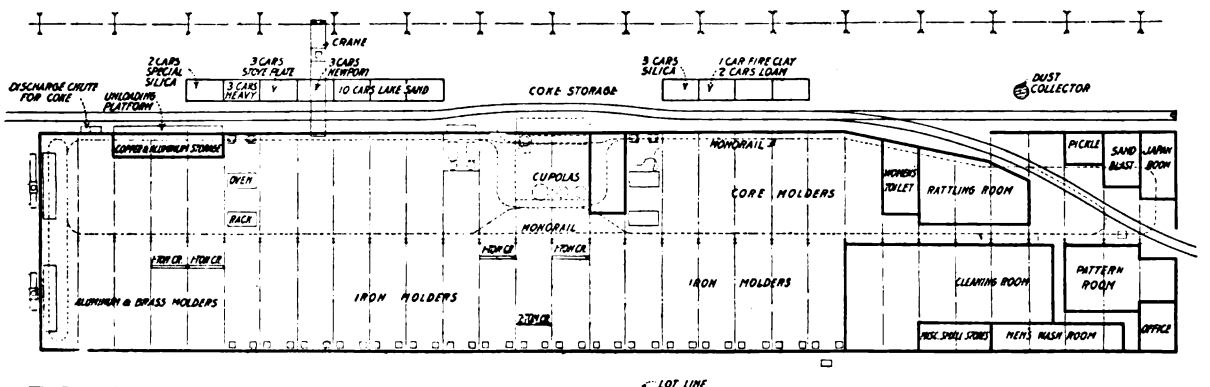

Fig. 1—General floor plan of the new foundry of the Nash Motors Company, Kenosha, Wis.

vided with extra large sash on both sides to give ample light to the center of the building. All of the monitor sash as above described is motor operated so that it can be opened and the lower section of all wall sash is pivoted for the same purpose, so that an ideal chimney effect is produced, air being admitted through the wall sash and noxious fumes and gases carried out through the monitor sash.

Artificial light is provided by means of 200-watt nitrogen-filled lamps with deep bowl metallic shades suspended from the roof trusses and spaced approximately on 20-ft. centers throughout the entire building. The side walls are also equipped with two 100-watt receptacles with angle reflectors on each pilaster and located about 8½ ft. above the floor line. Additional local lights are provided wherever desirable. All light and power conductors are carried in conduit and the various groups of lights are controlled from centralized panel boards located at readily accessible points.

Heating is by means of two blast coil fan sets located along the south wall, each set having a capacity to heat half the building. They are also interconnected. These heaters are supplied with exhaust steam from the main works and the heated air is distributed by means of underground concrete conduits extending along the north and

with cab and one 1-ton floor-operated electric hoist. Specially designed ladle holders equipped with 1-ton bull ladles have been made for attachment to the 3-ton hoists, so that molten iron may be received directly from the cupola and delivered to the small Brillion ladles suspended from the 1-ton cranes in each molding bay. Finished castings also can be picked up from the end of each molding bay and transferred to the cleaning rooms by this system.

A subsidiary monorail system, hand-operated, is provided in connection with the pickling tanks, sand-blast room and japanning room, so that castings can be received in the cleaning room, mounted upon this system and put through the pickling tanks, sand blasting and japanning ovens without being removed from the system. The entire installation of conveying apparatus is designed to reduce the manual conveying of material to the minimum.

The iron melting equipment is centrally located. The cupolas are three in number, having capacity of ten, five and three tons each, the two smaller brought over from the old foundry. The charging platform is a steel structure with its floor 15 ft. above the foundry floor line and extending from a line 37 ft. inside the north wall to a line 8 ft. outside the building wall. Access from the outside portion to the inside is had by means of sliding metal doors. The design of the charging platform is such that

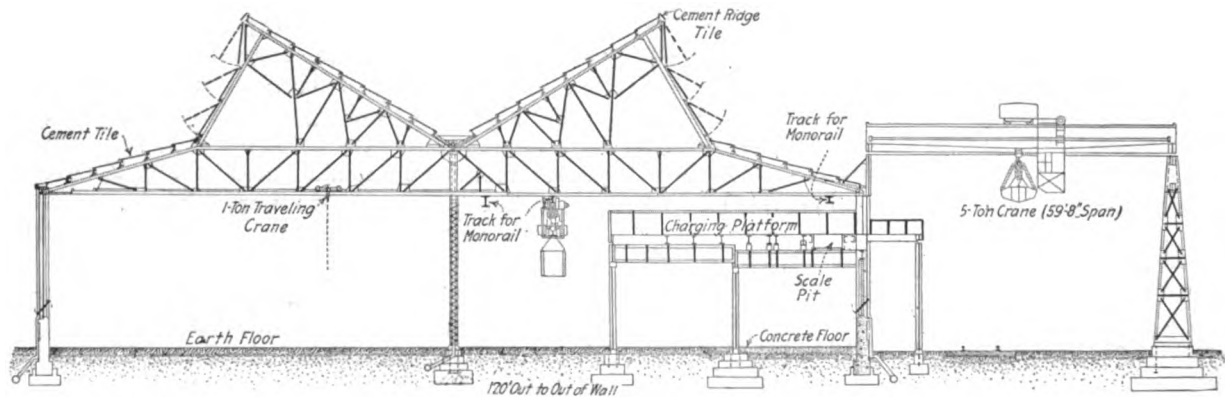

Fig. 2—Roof construction and general design of the building of the Nash Motors Company, as shown by the cross-section

south walls of the building. From these conduits sheet steel risers are brought up at each pilaster, from which the air is ejected into the room at a height of about 8 ft. above the floor line and in such manner as to blanket the cold outer walls. The heating system is designed so that all air may be taken from outside, or all from the inside for recirculation, or such proportions between the two sources as may be desired.

Steam and electric power is received from the main plant, the conduit and pipe being installed in an underground tunnel 6 ft. 9 in. high by 5 ft. 6 in. wide, extending from the east end of the foundry to the older portion of the plant, a distance of about 200 ft.

A complete monorail system consisting of 12-in. I-beams with the necessary hand-operated switches forms a loop along the north wall of the building and along the center line extending east and west, with cross-overs at several points and with a stub extending outside the building to the north, so that raw material may be received from the outside, if desired, and may be distributed to any point on the charging platform of the cupola, along the core benches, in front of the cupolas, over the crucible furnaces, along the front of the molding bays and to the cleaning room. This monorail is indicated in Figs. 1 and 2. The system is equipped with two 3-ton electric monorail hoists

pig iron, coke, etc., may be delivered from the storage yard by means of the outside crane directly to buggies on the exterior projection of the platform. In passing to the platform within the building, the charging buggies are wheeled on a traveling scale, just within the building wall on a depressed track, bringing its platform flush with the charging platform floor. After weighing the materials are wheeled to the cupola. The cupola blowers, two in number, are located on the foundry floor immediately in the rear of the cupola and under the charging platform.

Directly opposite the cupolas are 17 molding bays for gray iron castings, each bay extending 60 ft. from the south wall to the center line of the building and being 20 ft. wide. The floor of these bays is surfaced with about 4 in. of clay and each bay is served by a one-ton hand-operated Brownhoist crane hung on the lower chords of the roof trusses. Suspended from each of these cranes is a pouring device with a 750-lb. ladle. The hot metal is brought to the pouring ladles, as stated, in a one-ton bull ladle which is hung direct from the monorail trolley by means of a rigid latticed steel construction. This construction is novel in that the ladle is suspended from the trolley frame through a hinged connection rather than from the hoist, and possibility of the ladle's dropping is eliminated.

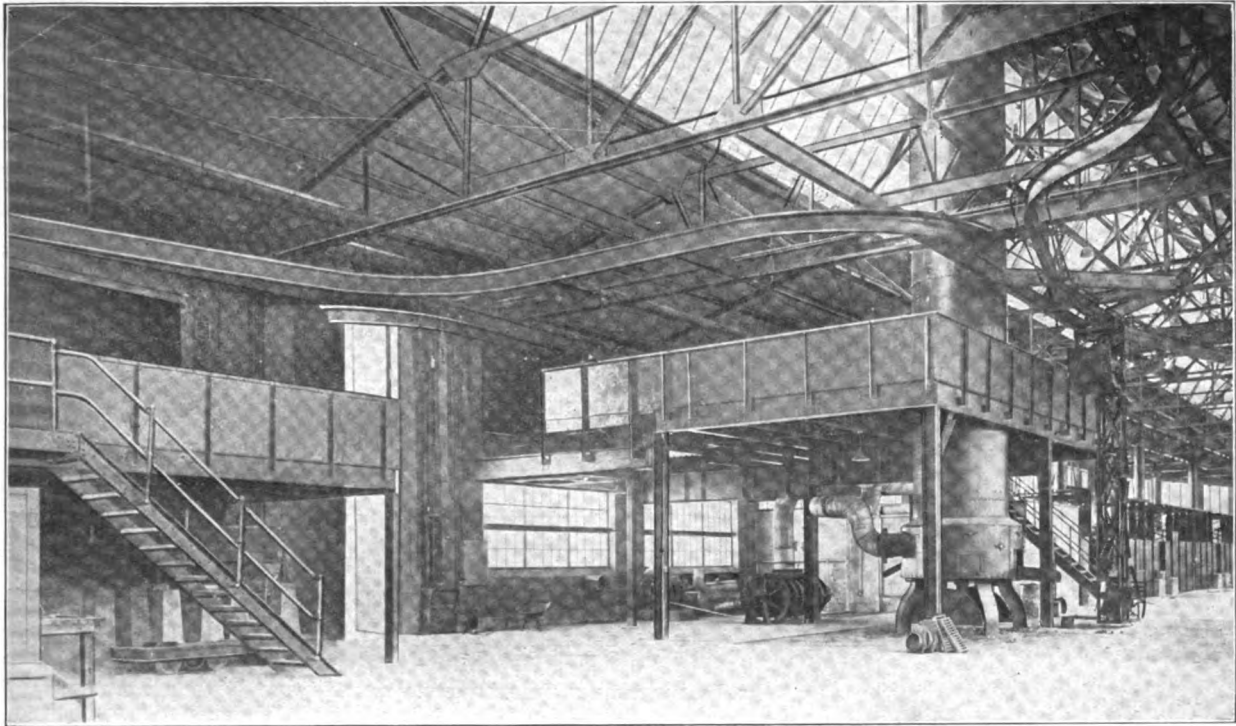

Fig. 3—Melting equipment in the foundry of the Nash Motors Company. Two additional cupolas are yet to be installed. At the left are shown the provisions for sand mixing.

Immediately west of the iron molding bays are four similar bays devoted to the molding of brass, aluminum and other composition castings. In the center of the west wall is a door giving access to the rear of the lot, for the disposal of refuse sand. Flanking this door on each side are the crucible pits, each affording accommodation for 12 crucibles. The center working aisle 8 ft. wide extends the entire length of the building just north of the center columns.

The work of this foundry involves the use of an exceptionally large number of cores. Roughly estimated the weight of core sand used will approximate one-half of the castings tonnage. The extensive provision for core-making indicated in the illustrations is thus occasioned. Six bays on each side of the cupolas are occupied by the core-making equipment, the section on one side providing for the making of small cores with women operators and the other for the larger cores.

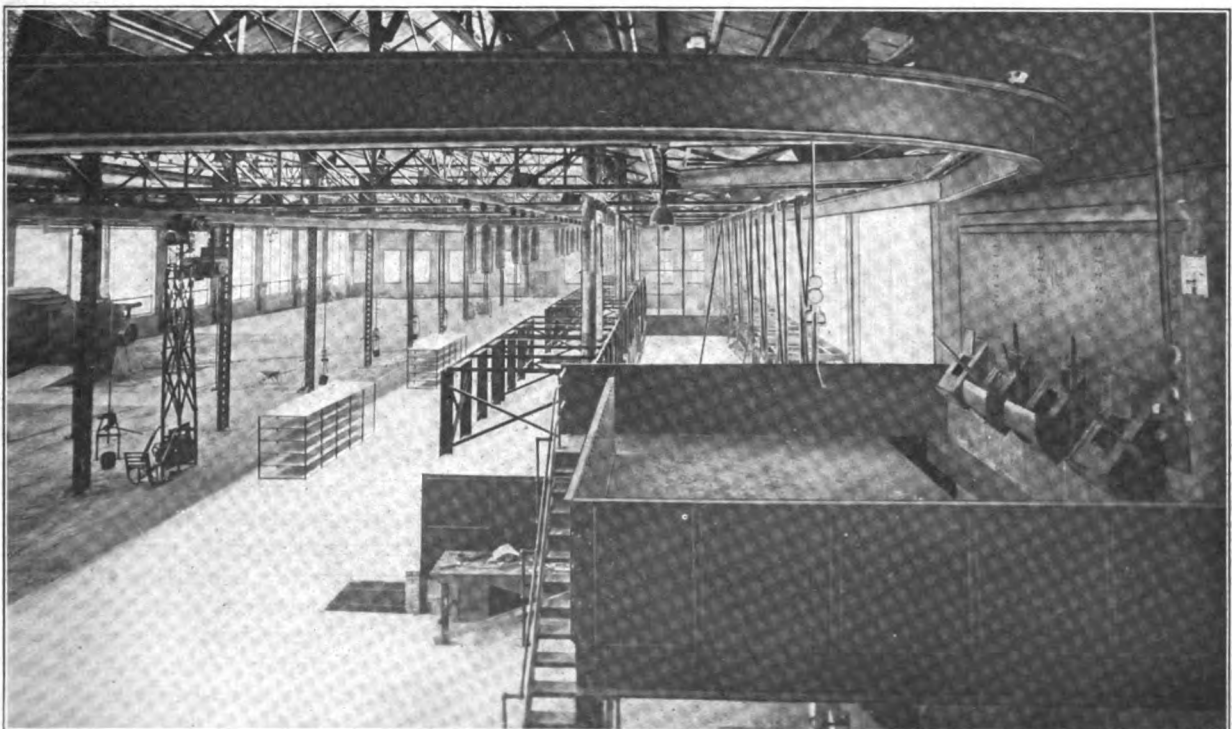

Fig. 4—West end of the foundry looking from the charging floor of the cupola. In the foreground are shown the sand spouts and mixing platform.

The core benches are each 5 ft. square, two to each bay, placed against the north wall. Above each bench is suspended an individual core sand bin designed to hold about one day's supply of prepared sand, which is fed by gravity directly from the bin to the core bench, as required. In front of these benches and separated from them by a 10-ft. aisle, are three batteries of double core ovens, each battery being 36 ft. long by 9 ft. deep by 7 ft. high, having a furnace at each end designed for coke firing and containing apartments for six core cars. Each battery is provided with a center partition so that either end may be fired independently of the other.

The core ovens are constructed of steel framing, with walls, roof and doors of channel frames double paneled with No. 16 gage steel sheets, the hollow wall between the paneling being filled with infusorial earth. Sliding doors are provided on each side of each compartment so that the core cars may

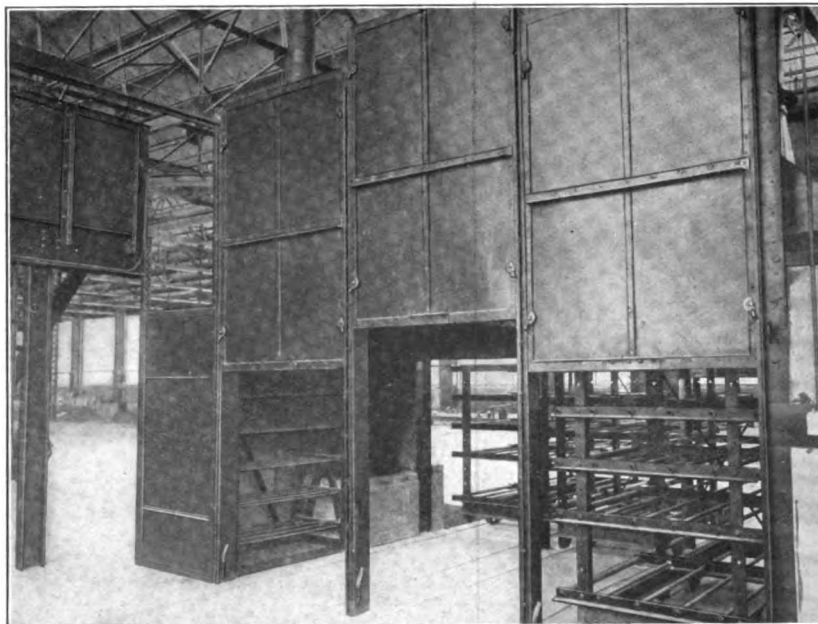

Fig. 5—The cars enter one side of the core ovens and deliver the baked cores at the opposite



Fig. 6—The craneway serving the raw material storage yard, the centrally located concrete sand bins, the inclined hopper for sand going to the mixer and the extension of the charging floor platform for the receipt of pig iron and coke for the cupola

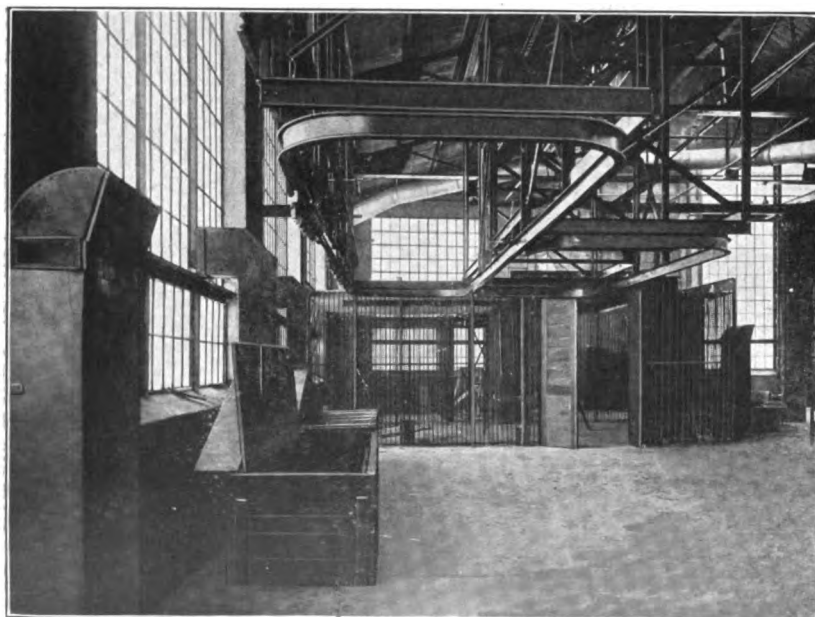

Fig. 7—The pickling tanks at the left, the sand blast room and beyond it the japanning ovens

be filled while standing between the core benches and the ovens, rolled into the ovens and thence out on the other side, where the cores are removed from the cars and placed upon storage racks within easy range of the monorail system for distribution to the mold floors as required.

Access to the outside of the building on the north is afforded by a set of double doors in the bay next west of the charging platform. The succeeding bay is occupied by the sand-mixing apparatus. Steel sand pockets are provided on the outside wall to receive sand from the outside storage, these pockets holding about three days' supply of sand. From these pockets the sand is delivered by gravity to a measuring bucket on the sand-mixing platform, thence by gravity to the mixers, from which it flows to portable bottom dump buckets which are conveyed by the monorail system to the individual bins above each core bench. An annunciator is placed above the sand-mixing

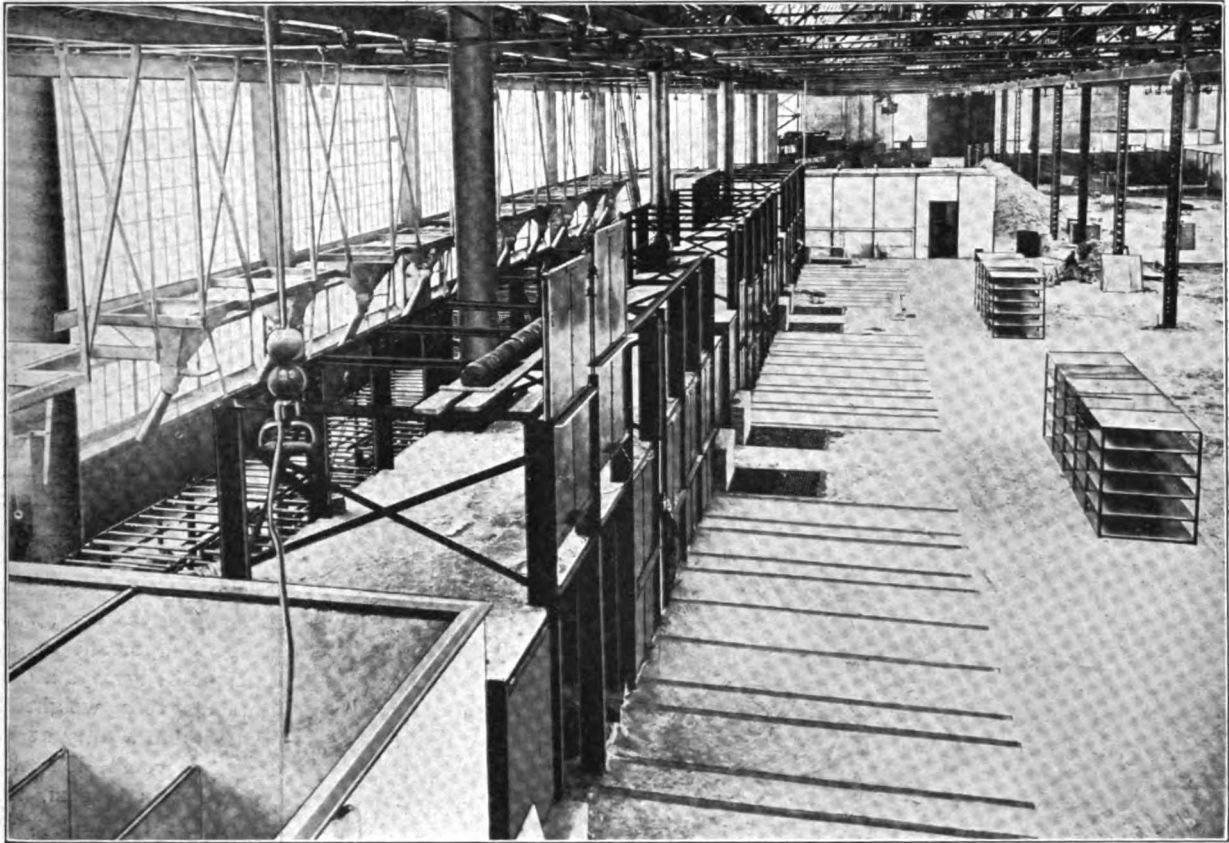

Fig. 8—Core ovens for women workers, and beyond the women's rest room, looking from the cupola charging floor

platform with signals corresponding to each core bench. By means of a push button at each bench the operator can indicate his or her need of sand.

A storage room for non-ferrous metals, 60 x 20 ft., is provided along the north wall of the west end and so located that metals can be unloaded from the cars directly into the room, weighed, stored and then conveyed to the crucible furnaces by the monorail system. Coke chutes are also located on this wall so that coke for the crucible furnaces and the core ovens may be delivered from the outside crane to the monorail system and thence distributed as required.

In the northeast corner of the building, occupying the triangle formed by the railroad track, are located the ovens for rough japanning crank cases, the sand blast room and pickling tanks. The triangle between the center line of the building and the track is occupied by the finished cleaning room. Immediately west of this cleaning room and occupying the width of one bay is the women's toilet, wash and rest room, 20 x 50 ft.

An office for the foreman, timekeepers and clerical force, 18 x 26 ft., is located in the southeast corner. Immediately adjacent thereto and extending along the southerly wall is the men's washroom, 70 ft. long by 14 ft. wide, the workmen's entrance being located at one end of this washroom, at which point are to be erected the time clocks. Between these rooms and the center line of the building is a pattern storage room, 38 x 60 ft., to which access is had from both the foreman's office and the body of the foundry. Here patterns for orders in the foundry are temporarily held pending use.

Extending along the entire north side of the foundry on the outside is a crane railway having a 60-ft. span and equipped with a 5-ton full electrically operated crane.

This crane is equipped with a magnet for handling pig iron and an independently motor-operated bucket for handling sand and coke. The storage space beneath this crane is used for flasks, coke and sand, there being provided 22 concrete sand bins, each 10 x 12 x 9 ft., with removable hatch covers.

A. N. Wilcox Heads Dayton Wire Wheel Co.

The Dayton Wire Wheel Co., recently incorporated at Dayton, O., with a capital stock of \$250,000, will manufacture wire wheels for automobiles. An interesting feature is the acquisition by the company of the Edgemont plant of the Pinneo & Daniels Co., which has been for years well known as a manufacturer of wooden wheels for horse-drawn vehicles. A. N. Wilcox is president and manager of the new company, having held the same position for many years with the Pinneo & Daniels Co., while Louis H. Rogge, of the Zwick & Greenwald Wheel Co., another wooden-wheel concern, is vice-president and treasurer. It is understood that the Pinneo & Daniels Co. will discontinue its wheel business, but that the Zwick & Greenwald company will not be affected by the new deal.

Wax Protects Body Finish

Protection for the body finish of cars awaiting shipment or being driven to destinations is afforded by a wax preparation, something like floor wax, that is being used with success by Detroit manufacturers, among them the Regal Motor Car Co., Detroit. The wax hardens after application and keeps the finish in good condition. Regal Traffic Manager Burke makes the suggestion that the wax might well be used by dealers to protect cars stored for the winter in dusty garages.

Carriage Manufacturers Worried Over Situation in Material Market

Thirty carriage manufacturing concerns were represented at a special meeting of the Carriage Builders' National Association in Cincinnati, O., on February 27, called by President Theodore Luth to discuss conditions in the trade which apparently make additional advances in the prices of vehicles inevitable.

Besides discussing the conditions which are preventing manufacturers from getting supplies of certain vehicle materials, the meeting gave careful consideration to a proposed cost system which it is expected will be adopted by all vehicle makers. It is already in use in some of the leading plants. Another meeting has been called for March 27 at the Gibson Hotel Cincinnati.

Letters were read from 20 concerns which supply various materials used in the construction of vehicles, telling of their inability to obtain sufficient fuel, steel and labor, and in some of these letters it was intimated that additional advances would be made in prices on the expiration of existing contracts. Much of the delay in shipping needed parts is due to the freight embargo in the east.

Reports from the manufacturers present indicated that none is supplied with all of the various materials required. All plants are carrying heavy stocks in some lines, but unable to procure certain vital parts. This condition, of course, prevents the completion of vehicles. Instances were related of manufacturers paying enormous premiums to get coal, in one case as high as \$175 per car. Some of the manufacturers reported cars of material shipped six or seven weeks ago and not yet delivered.

The reports also showed that stocks of vehicles in dealers' hands are light, and that manufacturers generally have a large volume of orders for shipment during the next three months. Whether they will be able to obtain the materials necessary to complete these jobs is a grave question.

A committee was appointed to confer with traffic managers of the trunk line railroads with a view to having moved without further delay carloads of steel, springs, axles, etc., now held up by the embargo. Other committees were chosen to investigate conditions in the material markets and report at the meeting to be held March 27.

The manufacturers attending the meeting were entertained at luncheon by the Carriage Makers' Club, and during the luncheon six new members were secured for the C. B. N. A.

Standard Parts Buys Bock Bearing Co.

The Standard Parts Co., Cleveland, O., has secured control of the Bock Bearing Co., Toledo, owners of more than 80 per cent of the latter company having consented to trade their holdings for Standard Parts stock and cash. Thus the already large company that contains the Standard Welding Co. and the Perfection Spring Co., and which last January completed arrangements for the purchase of the Western Spring & Axle Co. places itself in a position to make practically the entire running gear. In its original form it made springs, rims and tubular parts; the acquisition of the western company, still in process of legal accomplishment, increased its spring-making facilities to a truly immense size and added an axle plant; the Bock purchase enables the company to make bearings of the Bock taper type. William E. Bock,

president of the Bock company, will continue to head its affairs, and will be a director of the Standard company. The plant will remain in Toledo.

Only recent additions to the bearing plant were completed, by which the capacity was trebled, and it now is planned to turn out enough bearings to equip 350,000 automobiles during 1917. About 10,000 bearings a day will be made.

Motor Truck Opportunity in Spanish Capital

According to Consul Ely E. Palmer, an exceptional opportunity now exists for the inauguration in Madrid of an energetic sales campaign for motor trucks. The municipal government has decreed that within two years the cobble pavements of the city shall be replaced by asphalt or other similar surface. The two-wheeled carts and heavy wagons which are injurious to such surfaced pavements must necessarily be replaced by a different type of heavy vehicle, and it is probable that a wide-awake and well-connected representative would be able to dispose of a large number of motor trucks of various capacities.

The duty on motor trucks is 40 pesetas (\$7.72) each 220 pounds net weight, but it is important to note that a motor-truck chassis without the body pays a duty of 80 pesetas (\$15.44) per 220 pounds gross weight if such weight be less than 2,200 pounds, and a duty of 100 pesetas (\$19.30) per 220 pounds gross weight if such weight be more than 2,200 pounds. It would seem, therefore, that the shipment of the chassis alone would prove to be disadvantageous.

DuPont Fabrikoid Buys Marokene

The DuPont Fabrikoid Co., with main offices at Wilmington, Del., has purchased the Marokene Co., of Elizabeth, N. J. The Marokene Co. manufactures a material similar to fabrikoid, which is used extensively by the automobile, carriage and upholstery industries.

R. B. Heyward, who has been assistant superintendent of the Fabrikoid company's Newburgh plant, will become superintendent of the Marokene plant at Elizabeth, N. J. No changes will be made to the present staff of employees.

The purchaser will make thorough investigations in order to learn if any improvements can be made to the product and if possible will better same, thus upholding the DuPont standard.

All the sales transactions of the Marokene company will be under the direction of the Wilmington office, and the attention of J. K. Rodgers, sales manager of the DuPont Fabrikoid Co.

Metric System in Goodyear Plant

The metric system of weights and measures will be introduced in the plant of the Goodyear Tire & Rubber Co., Akron, O. All weighing measures, all mold designs and all machinery designed in the plant of the company will use the metric system. The completion of this move will extend over a period of months. Draftsmen are already provided with metric scales and drawings are being arranged along this line.

Armstrong Plant Damaged by Fire

Loss to the extent of \$25,000 was suffered by the J. B. Armstrong Mfg. Co., Flint, Mich., from a fire which attacked its plant. The company makes automobile springs.

Conditions That Control Truck Sizes

Restricted by Dimensions of Doorways, Elevators, Bridges and Boats

By A. F. Masury*

It is the purpose of this paper to present some existing and characteristic conditions that control and restrict the maximum overall dimensions of motor trucks and that prevent attainment of the higher efficiency that can be expected to result from an increase of vehicle size. In general the restricting factors are physical and legal, the legal being to a great extent directly determined by and the result of the physical.

Motor truck designers are being constantly confronted by engineering and contracting problems that would require motor trucks of capacities greater than at present existent and practical. The designer finds few things in the nature of pure automobile engineering problems that would prevent him increasing the size of trucks. The weight and dimensions of materials to be transported are constantly increasing, and it is the materials that are of prime importance in determining the size and type of vehicle to be used in their transport.

Existing Physical Factors

(A) Overall Height—The overall height of present motor trucks seldom exceeds 12 ft. The height is limited by the headroom necessary to drive under such structures as railroad bridges (grade crossings), enclosed or top bridges, elevated railroad structures, overhead trolley wires, doors, and ferryboats.

Railroad grade crossing bridges seldom provide less than 12 ft. headroom. Enclosed top bridges do not always provide as much as 14 ft. clearance. The doorways of modern garages, built to accommodate present motor trucks, are made with 12 ft. 3 in. headroom. However, few garage doorways exceed 10 ft. in height.

(B) Overall Width—The overall width of present motor trucks are in very few instances in excess of 96 in. This dimension is limited by the distance between parts of such structures through which vehicles must be driven, as doorways, elevators, boats.

Doorways of modern garages, built to accommodate present-day motor trucks, are made with a clearance between the butts of at least 10 ft. 9 in., which allows sufficient space for the fastenings of the doors without interfering with vehicles as they pass in or out. Elevators in modern truck garages are made 11 ft. wide.

Overall widths are to a great extent controlled by conditions that minimize the clearances between passing vehicles and stationary objects, as posts, trees, poles, elevated railroad pillars, curbs, etc., and that make negotiation both difficult and dangerous. Many state roads are paved over a width of but 16 feet; country roads are usually narrower than this. The difficulties of operating in congested city traffic tend also to restrict widths; small vehicles are more easily handled.

Length a Factor

(C) Overall Lengths—The material to be transported is the most important factor controlling length. Overall lengths of existing motor trucks seldom exceed 24 ft. Overall lengths of tractors and semi-trailers seldom exceed 35 ft. Ladder wagons for fire department use sometimes

attain lengths of 40 to 45 ft. Structural steel girders, telegraph poles, timbers and similar materials sometimes in excess of 60 ft. are transported by tractors and semi-trailers. Tractor and trailer trains have attained lengths of over 80 ft., but are difficult to handle because the trailers "cut under" on turns.

Lengths are also controlled and restricted by the difficulties encountered in negotiating turns, particularly where roads are narrow and cross at acute angles and stationary objects, as posts, poles, pillars, trees, etc., are located in close proximity to the sides of the roads, so that there is danger of coming in contact with them.

It is, of course, obvious that wheelbase length is the most important factor that determines the turning radius of motor vehicles and that the radius increases as the length increases. Existing structures tend to restrict length by making negotiation difficult. Modern truck garages, built to accommodate present vehicles require posts which are spaced at least 16 ft. 6 in. from the walls and 22 ft. apart; this allows three trucks to be backed in between the posts and allows the front wheels of most trucks to project beyond the posts. Aisles about 25 ft. wide provide turning space, which is usually sufficient for the trucks to be driven out from their positions. When a large number of trucks are stored, the difference in the sizes of small and large trucks allows this arrangement to be worked out with economy of space. These dimensions can be properly considered as of maximum average.

Elevators of modern truck garages are made 24 ft. long. Platform scales for weighing modern motor trucks are built to accommodate vehicles having a wheelbase length of 16 ft.

Trucks Classified

Trucks may be divided into three classes:

Type 1—This is the usual touring car type; the engine is over the front axle, the driver and control are behind the engine.

Type 2—In this type the engine is over the front axle; the driver and control are directly above the engine.

Type 3—The engine is over the front axle; the driver and control are on one side of the engine and the helper is on the other side.

Types 2 and 3 conserve the length of the chassis, as less space is taken for the driver's seat and control, thus allowing a longer loading platform in proportion to the wheelbase than type 1. The position of the operator's seat, whether back of or over the engine, usually affects the dimension of length to a greater extent than the height. When the seat is placed back of the motor, about 40 in. more frame length is required.

Tables A, B and C list motor truck data and show the most important, and what can be properly considered as average dimensions of motor trucks, as they are at present met with in practice.

Vehicles of maximum dimensions as follows have been either projected, designed or built, and are in a few instances extreme; the figures serve to show simply a few conditions.

1. 5½ ton tractor-trailer for transportation of milk, width 90¾ in., height 11 ft., length 321¼ in.
2. Truck equipped with body to carry timbers 85 ft. long.
3. 6½ ton 180½ in. wheelbase truck designed with racks to carry steel, width 96 in.

*Chief engineer, International Motor Co., New York.
A paper presented before the American Society for the Advancement of Science.

4. 2 ton 10 ft. wheelbase truck designed with special semi-trailer of 20 ft. wheelbase to transport aeroplane 30 ft. long.

5. 7½ ton tractor designed with special semi-trailer, which carries a foam tank of 15 tons capacity, height 10 ft. 6 in., length 26 ft. 9 in.

Table A—Most Important Average Dimensions

Type.	Cap. Base.	Wheel Length.	Length, Back of Cab.	Extreme Width, in Inches.	Height of Loading Platform, in In.		Clearance, in Inches.	
					Empty.	Loaded.		
Type 1	1-ton.	12 ft.	9 ft. 2	68	38	32	10	
	2-ton.	13 ft.	9 ft. 2	68	38	34	10	
	3-ton.	13 ft. 6	20 ft. 6	11 ft. to 11 ft. 6	87	42	38	10
	4-ton.	14 ft. 6	21 ft. 6	12 ft. to 12 ft. 6	87	42	38	10
	5-ton.	15 ft. 6	22 ft. 6	13 ft. to 13 ft. 6	87	44	38	10
Type 2	7½-ton.	16 ft. 6	23 ft. 6	14 ft. to 14 ft. 6	87	44	38	10
	3-ton.	11 ft. 6	18 ft. 3	12 ft. 6	87	42	38	10
	4-ton.	12 ft. 6	30 ft. 3	14 ft. 6	87	42	38	10
	5-ton.	13 ft. 6	22 ft. 3	16 ft. 6	87	44	38	10
	7½-ton.	14 ft.	23 ft. 3	17 ft. 6	87	44	38	10
Type 3	5-ton.	11 ft. 10½	18 ft. 1	14 ft.	93½	46	40	7½
	7-ton.	13 ft. 4½	20 ft. 1	16 ft.	93½	46	40	7½
	10-ton.	14 ft. 2½	22 ft. 1	18 ft.	93½	46	40	7½
Power-dump, Type 1	5-ton.	11 ft. 9	16 ft. 5	8 ft. 3	87	44	39	10½
	7½-ton.	12 ft. 10	17 ft. 5	9 ft. 3	87	44	39	10½

Legal Factors

A few of the restrictions imposed by legislation will suffice to show that the maximum dimensions allowed are in some instances even less than those of many motor trucks and in other instances are but slightly larger, and it appears that average motor trucks considered as a whole are rapidly approaching their legal limits.

The legal restrictions cited, while they are few in number, are fairly representative of the average legal maximums that would be determined by a more exhaustive study.

Chicago Ordinance, passed May 17, 1915, under subject: Tractors and Trailers; Regulations for Speed, Size and Capacity. Section 6 limits as follows: Maximum overall length of truck and trailer, 40 ft. Maximum overall width of truck and trailer, 102 in. Section 7. Permits issued

Table B—Turning Circles

Type.	Capac- ity.	Wheel Base.	Diameter of Turning Circle, in Feet.
Type 1—1-ton		10 ft. 6	47
		11 ft. 6	53
		12 ft. 6	55
Type 1—1½-ton		10 ft. 6	47
		11 ft. 6	53
		12 ft. 6	55
Type 1—2-ton		13 ft. 6	60
		10 ft. 6	47
		11 ft. 6	53
Type 1—3-ton		12 ft. 6	55
		13 ft. 6	60
		14 ft. 6	61
Type 1—4-ton		12 ft. 6	55
		13 ft. 6	59
		14 ft. 6	61
Type 1—5-ton		12 ft. 6	57
		13 ft. 6	62
		14 ft. 6	68
Type 1—7½-ton		12 ft. 6	57
		14 ft. 6	68
		15 ft. 6	71
Type 2—3-ton		11 ft.	47
		12 ft.	49
Type 2—5-ton		10 ft. 4	51
		11 ft. 6	53
Tractor—3-ton		10 ft. 4	40
		10 ft. 8	41

Trailer usually cuts under.

to operate train of trailers up to 100 ft. long between 8 p. m. and 5 a. m. at eight miles per hour.

Laws of Pennsylvania—90 in. maximum width over vehicle and load. Busses in cities of first, second and third class and tractor engines may be 100 in.

Laws of Maryland—90 in. maximum width allowed; tractor engine may be 100 in.

1904 Motor Car Order (England) limits the width of heavy motor cars or trailers to 7 ft. 6 in. Vehicles for military service in England are limited as follows: Maximum width 90 in. for 3-ton trucks; 90 in. for trailers.

High ton-mile efficiency leads to big units which is shown by a comparison of the cost of operation of trucks of different capacities.

From the foregoing it will be seen that the present physical conditions restricting the overall dimensions have largely been the controlling factors in establishing the legal restrictions. The present tendency in design is toward still larger units and is the result of the increase in ton-mile efficiency that is possible only with large units. We can reasonably expect physical changes in the future that will take place slowly and naturally and that will surely lead to conditions that will permit motor trucks to be increased in size far beyond the present maximum limits.

Bigger Units Coming

The amount of capital invested in the motor truck and its allied industries cannot be accurately ascertained and estimated figures are not available. However, it is obvious that it represents a proportion of the total money invested in the automobile and allied industries that is by no means small.

The National Automobile Chamber of Commerce estimates the number of commercial motor vehicles in the United States at 250,000, and the average cost of 1915 vehicles at \$2,000 each, 1916 vehicles at \$1,800 each. The annual expenditures on the construction and maintenance of highways in the United States is \$250,000,000. There are 2,121 automobile engineers in the Society of Automobile Engineers alone.

In face of these facts it does not seem unreasonable to expect that the inertia of money and the enlistment of engineering talent of the highest order in the industry will unite to accelerate change, and to overcome the present physical restrictions and the legal restrictions that together prevent the attainment of the maximum efficiency that it is possible for engineers to produce.

Table C—Important Dimensions and Turning Radii of Type 1 Trucks and Tractors

Tons Capac- ity.	Wheel Base.	Overall Dimensions (Inches).				Length.	Turn- ing Radius.	Length Back of Cab
		Width.		Height to Top of Cab Loaded.				
		Chain Drive.	Worm Drive.	Chain Drive.	Worm Drive.			
1	132	73¼	72¼	93¼	93½	205	22 ft. 148	
1½	144	73¼	72¼	93¼	93 11-16	217	25 ft. 150	
2	144	73¼	73¼	93 13-16	94½	217	25 ft. 150	
2½	162	73¼	73¼	94	94½	241	29 ft. 144	
3	162	73¼	73¼	94	94½	241	29 ft. 144	
3½-Trac.	119	84¾	84¾	98½	98½	180¾	*21 ft. 57	
3½	156	84¾	84¾	98 3-16	98½	225¾	25 ft. 132	
3½	168	84¾	84¾	98½	98½	249¾	26 ft. 3 154	
3½	180	84¾	84¾	98 1-16	98½	273¾	26 ft. 6 180	
5½-Trac.	119	90½	90½	98½	98½	180¾	*21 ft. 57	
5½	156	90½	90½	98 5-16	98½	225¾	25 ft. 132	
5½	168	90½	90½	98½	98½	249¾	26 ft. 3 154	
5½	180	90½	90½	98 3-16	98½	273¾	26 ft. 6 180	
7½-Trac.	119	93	93	98¾	98¾	180¾	*21 ft. 57	
7½	156	93	93	98¾	98¾	225¾	25 ft. 132	
7½	168	93	93	98¾	98¾	249¾	26 ft. 3 154	
7½	180	93	93	98¾	98¾	273¾	26 ft. 6 180	

*Trailer usually cuts under.

Hardwood Manufacturers' Convention

The fifteenth annual convention of the Hardwood Manufacturers' Association was held in Cincinnati on January 30 and 31, when the following officers were elected: B. B. Burns, president, Huntington, W. Va.; F. R. Gadd, first vice-president, Chicago, Ill.; E. O. Robinson, treasurer, St. Albans, W. Va.

Paint Shop

Ways and Means of Painting and Finishing the Automobile

The metal surface, as distinguished from the wooden one, has for the most part, its finish baked on; and by finish we mean to say all the coats, from primer to the finishing coat of varnish. When one of this class comes in with the paint splintered and flaked off to a greater or less extent, it is quite a problem to determine just what to do with it. The character of the steel, its temper, etc., have much to do with securing for the paint and varnish a secure foothold. Then the question of rust often arises, and this feature must be handled so that the fresh coats may stay in place. If one were located where a sand blast machine could be had, the rust might be taken off at small expense and most effectively. Without this machine, it is up to the painter to devise some means of removing the rust before painting. The places may be emiered out so that the bright metal shows clean, and for small patches the emery wheel will do very well.

As soon as the rust has been cleaned off, says M. C. Hillick, in *American Blacksmith*, the metal needs to be coated at once, using a pigment that is to some extent, at least, rust inhibitive. A good metallic paint, mixed in pure linseed oil, will serve the purpose of a good primer and help to hold the rust and corrosion in check. Upon this pigment another coat of surfacing medium should be placed. Then with a hard, drying putty, fill the cavity or depression level with the surface about it, allowing a trifle for shrinkage. In due time, rub these places down, using for the work a block of artificial pumice stone, or rubbing brick, this to be dipped in a mixture of raw linseed oil and turpentine, instead of water. Before coating up these splotches, it is always advisable to make sure that the edges of the broken surface are sound and good, paying particular attention that all the fractured edges which may be slightly loose, or inclined to scale, are taken down to the hard metal. This will then provide a sound base for the coats to be applied. By letting some of the surface lap over the edge of the defect, the entire surface—the old and the new alike—will be as one when the rubbing has been completed. After this, the other spots on the body of the surface should have a touch up with the right color, following which a coat of varnish-color may be flowed on.

For a cheap or ordinary job this color-varnish will serve as the ground for the finishing coat of varnish, thus bringing the work along to a finish at the expense of just two coats of material, plus the touching up and mending of the fractured spots. It is always better practice, however, when the job must be striped and fixed up some with ornamental lines, to cut on over the striping a coat of clear rubbing varnish; rub this coat in due season with pumice-stone flour and water, to bring out the surface to a finer condition, and then apply the finishing coat. Either method will furnish a medium-priced job, the latter at the additional cost of the one coat of rubbing varnish.

There is another class of jobs which drift into the shop which fetch the ingenuity of the painter into play. They

are the ones upon which the finish is cracked and fissured so badly that without burning off, the surface must be faced up and made to look quite like new. Burning off would, of course, solve the problem; and if not burning, then removal of the paint and varnish through the use of varnish remover. But not much of this sort of work is done nowadays, except in the cities and larger towns, and upon the finest grade of work. To take the finish off the steel or aluminum surface by burning is next to an impossibility; too expensive, at any rate, to be considered here. Varnish remover of the paste variety will do the trick, but this, too, is a somewhat expensive proceeding, except for the very highest class of work. So we shall not take any space at this time, at least, to describe the way of using the remover or the best method of burning off.

For these cracked and fissured surfaces give, as a first step, the work a thorough sandpapering with No. 1 paper, or No. 2, making choice to suit the surface conditions. Then follow with a coat of lead paint shaded with some color to meet the needs of the work, using in this material one part raw linseed oil to five parts of turpentine. Get a generous coat of the paint over the surface, but not more than the work will take care of. Rub the coat out well in order to have the cracks take up plenty of the filler, so that in turn they may help to clinch the facing up putty. Let this coat dry until it is hard enough to fly off in a fine powder under the sandpaper. Then go over the surface lightly with No. ½ sandpaper, after which take a mixture of three parts of dry white lead and one part refined whiting, mixed to a stiff paste in equal parts of rubbing varnish and coach japan, and with a broad, half elastic scraping knife draw putty the entire surface, taking care to work the pigment on very smooth and free from knife marks, these latter being almost impossible to sandpaper out. By being careful in putting this putty on and smoothing out, the work of sandpapering down can be reduced to the minimum, and for cheap work, the surface when thus sandpapered, will go very nicely by putting on the one coat of selected body color, then one coat of varnish-color, and one coat of finishing varnish, provided no lining work is desired.

If a better grade of work is required, proceed, after draw puttying the surface, to lay on a couple of coats of roughstuff, and then in due time rub down with artificial rubbing stone or brick, using for the dipping medium a mixture of equal parts of raw linseed oil and turpentine. This will give a good, substantial foundation to work upon, and under a fair finish to protect it, will wear durably, for an old surface. Another and cheaper method consists of sandpapering the work done as already described; then coating over with a stiff mixture of roughstuff filler beaten to a working condition in a quantity of orange gum shellac. Use a fairly stiff brush and apply quickly, as the shellac filler sets up very fast. This working condition needs to be a little thinner than regular coats of filler; in this shape it will penetrate the checks better. Put on two or three coats of this filler, and then

the next day rub down in the way outlined above. Bring out to a finish in the same way that it is made over the facing up putty. By exercising care and skill in sandpapering, and in rubbing when it is thought necessary to do this, a good looking job may be turned out, and the labor cost kept down to a reasonably small limit. For a first class job over this old foundation, the surface may be coated up with several coats of regular roughstuff, over a primary filling up coat, the deepest crack being draw puttied, as above detailed.

The Theories of Color

At one time there existed two theories of color. One was that discovered by Sir Isaac Newton and adopted by Sir David Brewster and other philosophical writers on chromatics. It was found by Sir Isaac in the following manner:

In the window shutter of a darkened room a hole of about one-third of an inch diameter was made, behind which, at a short distance, a prism was placed, so that a ray of the sun's light might enter and leave it at equal angles.

This ray, which before the introduction of the prism proceeded in a straight line and formed a round spot upon a screen placed a few feet distant from the window, was not found to be refracted, appeared of an oblong form, and composed of seven different colors of the greatest brilliancy imperceptibly blended together, viz., violet, indigo, blue, green, yellow, orange and red. This is termed the solar or prismatic spectrum.

The theory established by this experiment was that the white light of the sun is composed of several colors which often appear by themselves, and that this white light can be separated into its elements.

By making a hole in the screen upon which the spectrum is formed opposite to each of these colors successively, so as to allow it alone to pass, and by letting the color thus separated fall upon a second prism, Sir Isaac found that each of the colors was alike refrangible, because the second prism could not separate it into an oblong image or any other color. Hence he called all the colors simple or homogeneous.

The other theory was that which seemed adopted by almost all who had written on coloring connected with the fine arts, and was that there were only three simple or homogeneous colors, and that all others resulted from them. Although this theory was not set up in opposition to that of the natural philosophers, but seemed only to be established in a practical point of view, neither was it supported by any scientific experiments; yet it appeared to some more consistent with the general simplicity of nature, and they could not believe that she required seven homogeneous parts to produce what art could do by three. For example, artists can make all their colors and, indeed, a correct representation of the prismatic spectrum (as far as the purity of their materials will allow) with three colors only; while according to Sir Isaac Newton's theory, seven simple or homogeneous colors were employed to produce the real one.

The following discovery made by Buffon and illustrated by succeeding philosophers helps to strengthen the conviction that the scientific theory might, like that of the practical artist, be reducible to three simple or homogeneous parts.

If we look steadily for a considerable time upon a spot

of any given color placed on a white or black ground, it will appear surrounded by a border of another color. And this color will uniformly be found to be that which makes up the triad; for if the spot be red, the border will be green, which is composed of blue and yellow; if blue, the border will be orange, composed of yellow and red; and if yellow, the border will be purple—making in all cases, a triunity of the three colors called by artists "homogeneous."

With a view to throw some light upon the subject as opportunities allowed, the experiments by which Sir Isaac Newton established his theory have been tried over from time to time. The same results occurred. We cannot separate any one color of the solar spectrum into two. The imperceptible manner in which the colors were blended together upon the spectrum, however, and the circumstance of the colors which practical men term "compound" being always placed at the adjunct of the two of which they say it is composed, caused a continuance of experiments, and while it could not be proved by analysis that there were only three colors it was proved synthetically in the following manner:

After first trying every color in succession and finding that none of them could be separated into two, a hole was next made in the first screen in the center of the blue of the spectrum, and another in that of the red. Thereby was procured a spot of each of those colors upon a second screen. Then, by means of another prism, the blue spot was directed to the same part of the second screen on which the red appeared, where they united, producing a violet as pure and intense as that upon the spectrum. The same was done with the blue and yellow, and produced the prismatic green; as also with the red and yellow, and orange resulted.

An attempt being made by the same method to mix a simple with what was thought a compound color showed they would not unite, for no sooner was the red spot thrown upon the green than it vanished.

The same was tried with two spectrums, the one behind and a little above the other, when a spot of each color was passed successively over the spectrum, which was furthest from the light, and the result was the same.

It follows that these three colors have an affinity to one another that does not exist in the others, and that they cannot be the same in every respect, except color and refrangibility as was at one time taught.—John M. Fife, in *Decorators' and Painters' Magazine*.

Fire Prevention Methods for Master Painters

Let me call your attention to what appears to us to be absolute fire prevention necessities.

Don't neglect to sweep out your shop every day.

Don't allow waste, oily rags or dirt to accumulate in the corners and behinds barrels or tanks.

Don't neglect to have in convenient places a good supply of five-pound paper bags of dry sand; it does not freeze or cost anything. The throwing of a single bag may put out a fire, and will do it in paint and varnish factories, and it has proven to be the salvation of very many plants.

Don't neglect to have a self-closing can in every room for the reception of oily rags and waste; and you should have some place where this should be emptied and burned every night at close of work.

Don't allow your workmen to throw their overalls upon

the floor, or upon a bench or shelf, but have a metal-lined closet for them, and require them to be hung up every night. A dirty, oily pair of overalls will take fire by spontaneous combustion if they get some light or air in a warm room.

Don't fail to use vapor-proof globes upon all lamps.

Don't have any open lights.

Don't permit any open cans of benzine or turpentine substitute in your shops. It should be kept outside and pumped inside as you use it. You may not think this is necessary, but it absolutely is. We ask you not to forget that petroleum vapors are heavier than the atmosphere. They do not rise, but fall and lie upon the floor; hence do not allow any smoking in your shop. A lighted match thrown upon the floor is very dangerous, as the gases are there. Vapors released in an upper room will ignite in the basement. We regard smoking in your shops as being absolutely dangerous, and should not be tolerated. If you handle glass, you have straw scattered about. Your workmen are careless and throw down lighted matches and do not see why they go and many times do not care.

Every defect that you correct lessens your rate of insurance. Cleanliness should be your watchword. Close your shop tight at night; do not let drafts of air pass through it. You may not know more than 50 per cent of the fires in paint factories and shops are from spontaneous combustion, and this is largely increased by a draft of air. It may smolder for many hours, and even for days, but a draft of air will fan it into a blaze.—M. S. Clapp, in Decorator.

Quinby Retires From Business

J. M. Quinby & Co., Newark, N. J., one of the oldest carriage and automobile body builders in this country, has decided to retire from business, after a period of 80 years of high grade carriage and body building. With the retirement of this company one of the pioneer builders of automobile bodies leaves the industry. This company started building automobile bodies as far back as 1900 and was one of the first to use aluminum in their construction. When it was found that aluminum could be used in the construction of bodies, the Quinby company sent a representative over to Europe to study its practicability and as a result has since manufactured its bodies with that metal.

The company has specialized in high class body work, doing a large part of the body business for foreign cars. Much of the special body work on Simplex cars has come out of this factory. From time to time the company has planned entering the automobile manufacturing field and the present retirement may be a step toward that end.

The company has put its \$400,000 plant on the market and is cleaning up all its business, refusing new orders. According to plans it will sell the plant with or without the good will of the business.

The company is capitalized at \$200,000 and the officers are: President, W. W. Ogden; vice-president and treasurer, H. D. Ogden.

Receiver for Enger Though Solvent

When Frank J. Enger, president of the Enger Motor Car Co., Cincinnati, O., committed suicide, on January 4 last, he left full instructions for the continuing of the business by Daniel McLaren, vice-president. He also left notes totalling \$80,000 for which he was surety, and the

combination of the two kinds of notes has brought the company into the hands of a receiver, Louis J. Dauner, on petition of Enger's widow, Mrs. Pearl R. Enger. McLaren, vice-president of the company, consented to the appointment of the receiver, who will have the task of reconciling various differences among those in control of the company, the creditors and Mrs. Enger.

Too literal following out of the instructions left by Enger for the conduct of the business is given as the cause of the present difficulty, which is more one of policies than of finances, as the assets are said to exceed the liabilities by over \$150,000. Mrs. Enger, however, claims that unless a more active business policy is instituted, the assets will be dissipated and her equity in the company injured.

In her suit Mrs. Enger says that the company has materials and parts on hand worth \$130,000 if continued as a going concern, while it owns the plant at Gest and Summer streets, worth more than \$150,000, it is declared. Other assets amounting to \$50,000, Mrs. Enger asserts, bring the total assets up to \$330,000. The company has large contracts for cars on hand, she sets forth, and deposits have been made upon these by agents, but agents and other creditors are seeking payment of their claims against the concern, liability for which has been denied by the company, which declares that Enger assumed all these claims himself.

End of Long Drawn Out Litigation

Creditors of the New Decatur Buggy Co., and of H. H. Haines, receiver of the company, will receive some return on their claims, considerably beyond what they had expected, as a result of the judgment of the United States District Court holding the receiver's bond, secured by the American Bonding Co. and the Fidelity & Deposit Co., liable for certain indebtedness incurred by the receiver in excess of the authority conferred upon him by the court. The judgment amounts to nearly \$15,000. The receiver must also pay about \$2,000. The Buckeye Wheel Co. and other creditors are affected. This will dispose of long-drawn-out litigation.

Booth Arrives With Sectional Body

Robert Booth, of Johannesburg, S. A., has arrived in New York with a sectional automobile body, in which he is interesting manufacturers, with a view to the export shipment economies that his invention renders possible. The design, which was described by The Hub about one year ago, permits the entire body to be knocked down and packed for shipment in exceedingly small space. When shipped in conjunction with a chassis, the body sections can be stowed in the crate in such a way as to require practically no more space than would be necessary for the chassis alone. By this means at least 50 per cent can be saved where bodies are shipped without chassis.

Vehicle Day

Thursday, March 29, will be vehicle day with the Western Classification Committee which meets in Chicago at that time. A large number of changes are docketed for consideration. They relate mainly to crating, including size of crates and material used. Some changes in classification are also proposed. The changes also involve farm wagons, trucks, carts, etc.

Why a Wheel Is Dished

The following from an English exchange (Work) while on an old subject that has been discussed ever since wheels have been built in their present form, will interest every vehicle worker.

Whether or not the design of the vehicle is adapted for dished wheels, and that is—an upright wheel is rigid, a dished wheel has a certain amount of spring, consequently a tire will remain on a dished wheel an infinitely greater time than it will with one that has the spokes at right angles with the center of the hub. This is due to the well known laws of expansion and contraction. The iron tire lengthens in hot summer weather and shortens in cold weather. On the other hand, the timber of the felloes and hub shrinks in hot summer weather and swells with wet in winter. Consequently, with an upright wheel on a cold day, the ends of the spokes are forced into the felloes and hub as shown at A and B (Fig. 1) by the con-

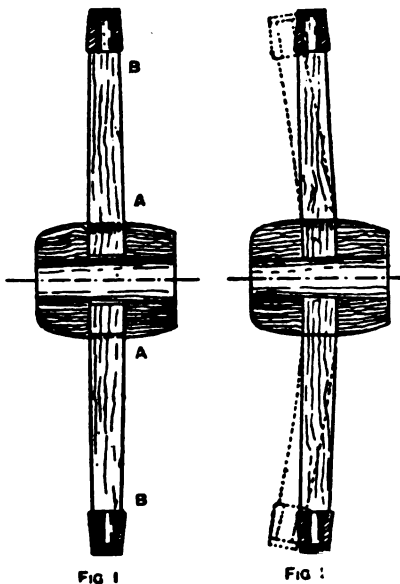

FIG 1
Why is a wheel dished

traction of the tire, and the swelling of the timber at the same time leaves a permanent housing of the shoulders at the tang and tenon which permits the tire to become loose when it expands with a change of temperature, and if this is accompanied by dry weather, the shrinkage of the timber makes matters worse. Now as long as a tire is tight, even if the timber is old and poor, the wheel will run safely; but work it with a loose tire, even if this is held on with nails or bolts, and the wheel will soon get beyond repair.

With a dished wheel the contraction of the tire, instead of forcing the shoulders into the hub and felloes, simply bends the spokes as shown by the dotted lines in Fig. 2. Consequently the wheel is slightly more dished on a hot day than a cold day. When a wheel is made, an allowance is given for the tire to pull it a little more into dish. Consequently there is a certain amount of initial stress on the spokes which give and take with the tire changes and the load. In an upright wheel, the spokes are struts; in a dished wheel they act as combined struts and cantilevers. When a vehicle is loaded, the tendency is to distort the wheel to an oval form; but any distortion of this kind of an upright wheel could only take place by forcing the top and bottom spokes into the felloes, leaving the horizontal spokes loose at the shoulders. With a dished

wheel, the vertical spokes bend a little more, and those that are horizontal lose a little of their initial bend. Moreover, the spokes in a well-made wheel are especially shaped to give the maximum of strength with the minimum of weight under these conditions.

The probable reason why wheels were dished in the first instance was to allow for a greater loading space at the top, without interfering with the track of distance between the wheels on the road. This was a very important point in the old days, when all vehicles had to keep to the rut or turn over, and when the superiority of a dished wheel had been demonstrated, it came into general use.

Our present-day wheel has taken some 4,000 years to develop, and the only real improvements in modern times are the introduction of the artillery hub and the rubber tire. For a record of the failures to effect improvements, one has only to call a patent office library and look up the old specifications.

Philadelphia Vehicle Builders' Banquet

The Carriage and Wagon Builders' Association of Philadelphia will hold its twenty-second annual banquet at the Hotel Hanover, Twelfth and Arch streets, Philadelphia, on Thursday evening, March 29. The banquet will begin at 8:30 o'clock and there will be dancing from 11:30 p. m. to 1 a. m. A first class orchestra will be provided. Cards of admission cost \$1 and can be obtained from August Geissel, Jr., 487 North Third street, Philadelphia. Although retaining its time-honored title, this association comprises within its membership very few men who give their attention to carriages and wagons. Practically all the members do automobile work, manufacturing new bodies and repairing old ones. Most of the wagon builders belonging to the association are building motor truck bodies.

U. S. Spends \$34,500,000 on Trucks

In the past year the United States War Department spent about \$34,500,000 for the purchase and operation of motor trucks. Only \$23,000,000 was appropriated for this purpose in the last army bill, so an estimate of \$11,415,770 as a deficiency appropriation has been submitted.

The government bought about 2,300 trucks, mostly for use in the Mexican border operations. Some of these machines are now stored at Fort Bliss, Fort Sam Houston and at El Paso, Tex.

Two large army garages are to be built at Fort Bliss and Fort Sam Houston and plans are being prepared for the erection of another at Brownsville, Tex. The buildings will be of a permanent type of construction for the repair and maintenance of army motor trucks.

New York Has 25,000 Troop Trucks

A census compiled by Francis M. Hugo, secretary of state of New York state, shows that the state could contribute about 25,000 motor trucks in case of war. Mr. Hugo has figures showing that there are more than 20,000 trucks in the immediate vicinity of New York City that, on a few hours' notice, in the event of hostilities, could be made available for the transportation of troops and munitions through Long Island, New Jersey and along the Atlantic seaboard. There are more than 317,000 pleasure cars registered in New York state, with which the military authorities could move a big army at very short notice.

New Four-Passenger Type Incorporate Fine Lines With Utility

Roadsters are passing through a change in design. While they have always been known as vehicles of neat appearance, they are now being made to serve purposes of great utility. Two years ago the roadster had fallen off in popularity; it has now regained this popularity on a larger scale than ever before. The reason is not hard to find, as it simply lies in the fact that designers have been able to retain the racy lines so much liked in the roadster and still have added the comfort and all-around utility of the small touring car.

During the past year, writes Merle Shepard, in the *New York American*, a great many four-passenger roadsters have come into use and these do not depart in exterior lines to any great extent from the roadsters of two and three-passenger capacity which were formerly manufactured, but these have been in turn improved by being provided with large carrying capacity for baggage and packages. About two years ago it was a question among manufacturers as to whether or not the roadster would be continued as a stock model but would, on the other hand, be made up specially whenever a customer ordered that type. Some of the manufacturers, in fact, actually did cut out the roadster as a stock product, just making up a few for special demand.

This is changed now, since the wider adaptability of the roadster has been realized. We see fewer of the race-about type and more of the cloverleaf, clubster and other adaptations of the multi-passenger roadster. The race-about was most often made as nearly an open car without top or side curtains, and very often without even a windshield. This limited the use of the car to short distance travel in fine weather unless the driver wished to put up with a great amount of discomfort. Even when a top was fitted to the car the type did not lend itself to weather tightness, and the result was a vehicle of restricted usage, which had the good point, however, of speedy appearance and trim lines.

As a result of the conditions of the roadster during this period of its design the owners of such cars were naturally those who were willing to sacrifice a large degree of comfort to obtain the semblance of speed, whether or not the car was capable of producing it. The owner of a so-called classy roadster was sure to be a more or less dashing young person, who did not go on extended tours, but merely used the car for visiting, for trips to the country club or golf course and for skipping about in the vicinity of his home.

Realizing the demand for a car which would conveniently take out a couple with a child, a guest, or perhaps even two guests, designers have been working for a long time on some sort of suitable body. It does not look well for two people to travel in a touring car, merely occupying the front seats while the spacious tonneau is absolutely lost. A car that is a roadster when it has to carry two people and is a touring car when it has to carry four is a much more elastic proposition, and one in which appearance is carried out, no matter how many occupants it may have.

About the first development in the multi-passenger roadster was when the front seat design was used with a little rumble seat mounted on a rear deck. Many of these were seen on the streets back as far as 1910, and occasionally even sooner than this. This was highly unsatisfactory,

however, as the rumble-seat passenger was always uncomfortable, due to the lack of upholstery on its seat, and also he was cut off from the remainder of the party, being unable to hold conversation with them, even when he shouted.

The next development in the way of adding more passengers to the roadster was accomplished by the simple method of widening the seat. This type of roadster, known as the sociable type, was adopted by two or three manufacturers with great success. The seat was very roomy for two passengers, and quite roomy enough for three of ordinary size. It had its drawbacks, however, in that the three passengers were not always of the required size and hence the driver was apt to be uncomfortable in attempting to operate the control mechanism of the car. The middle passenger always interfered with the movements of the driver's elbow when he operated the gear shift lever, and when the passengers were of larger size than usual it would be even difficult to manipulate the steering wheel.

In overcoming the objections to the ordinary type of wide-seat three-passenger roadster, the next step in roadster design was unconsciously accomplished. The body workers, seeing that the driver was inconvenienced, simply brought the driver's seat ahead of the wide seat, giving him plenty of room for his elbows and, incidentally, greatly increasing his range of vision on the side in which the passengers were carried. This not only gave room to the driver, but also gave room for the passengers, and at the same time all three occupants were close enough together to hold a conversation at ordinary tones.

In weather protection, the type of vehicle described offered as much as the touring car. The top was carried in the same manner as on the touring car, and had the advantage of speed in mounting. The passengers of the roadster could put the top up and also mount the side curtain in much quicker time than the occupants of the touring car.

With the driver's seat advanced a small space equal to the amount of advance was always left behind his seat. It was not long before the possibility of converting this into another handy package compartment was realized and this offered another advantage in this type of roadster. Package-carrying capacity came to be a much-studied part of the body design, and just about at this phase of roadster development a great many ingenious compartments began to be fitted to the cars for carrying gloves, goggles, small parcels, and even rather bulky packages which could be accommodated beneath the rear deck. The tires were carried concealed on some of these cars within the space below the rear deck.

With all its advantages, the type of roadster described had one great disadvantage. It departed from the trim roadster lines which we have always liked to associate with this type of vehicle. The trouble was that the total width was too great, making the body more bulging than could be possible in connection with the low, long lines necessary in making a roadster have the fleet and graceful outline which is responsible for the introduction of the style. Two passengers seem to be all that can be carried and still preserve the fine lines, where all the passengers are confined to a single seat. This fact brings us to the next development of the roadster, the cloverleaf.

The cloverleaf roadster carries the passengers, as its name expresses, in the form of the leaves of a three-leaf clover. Two passengers sit abreast and one immediately

behind. There are two doors in the car, one at each side of the front seats, in the same way as in the ordinary two-passenger roadster. The front seats, however, are divided or individual, with a passage between through which the passenger in the rear seat can enter. This type of vehicle can have the narrow body which is necessary to the racy line. It is capable of being made to have a very neat appearance, and when it was introduced in 1915 it immediately found favor. The car was used very much as the old style roadster was used for country club work, but it had the additional feature of weatherproofness.

Where the cloverleaf fails is when the designer neglects to leave enough room for the rear passenger. In fact, as a three-passenger car it is more easily built than as a four, because there is generally leg room for the third passenger in the passage between the two front seats. When it is built as a four-passenger car by widening out the extra passenger seat it becomes extremely difficult to preserve the cloverleaf form and still have room for both rear passengers. The four-passenger roadster, which has just been developed, is a further adaptation of the cloverleaf idea. There is more room in the rear because it is made very much in the form of a close-coupled tonneau. Still, with all the greater room, the roadster lines have not been departed from in the least.

By the use of only two doors and by skillfully tapering off the rear end of the body, the effect of the room in the rear compartment on the outlines of the car is minimized. The occupants can all be made comfortable, and by mounting this body on a chassis whose wheelbase is as long as that of a corresponding touring car, a great amount of space can be saved for baggage. This makes an excellent car for cross-country work, while at the same time if occupied by one couple it is not a bad-appearing vehicle.

Kardo Patent Upheld

The Kardo front axle patent has been upheld by the United States District Court of Appeals which declared it infringed and upheld the validity of claim 1 of patent No. 753,820, granted March 1, 1904. According to the decision the decree of the lower court in the suit of the American Ball Bearing Co. against E. B. Finch, a former Cleveland Chalmers representative, is reversed. The decision of the lower court held the Baker patent void, upholding the prior art claims of the defense from which the American Ball Bearing Co. appealed. The patent has to do solely with the means for mounting and turning the front wheels of motor cars.

Mitchell Wagon Co.'s Big Record

The Mitchell Wagon Co., Racine, Wis., held its annual stockholders' meeting February 5, for the election of directors and officers. The company's reports show that during 1916 they sold the largest number of farm wagons ever sold by the company in any one year; and at the first of the year they had orders for 13,086 wagons for delivery during 1917. The officers elected were: President, Martin J. Gillen; vice-president, Rodney Parvis; treasurer, Raymond G. Haines; secretary and assistant treasurer, J. C. Oliver. The directors are: Frank H. Haines, Charles E. Killian, Raymond H. Weins, H. B. Clark, David Lanman, Rodney Jarvis, Martin J. Gillen.

Barley Moves Into Michigan Buggy Plant

The Barley Motor Car Co., Streator, Ill., which makes the Roamer car, has purchased part of the plant of the Michigan Buggy Co., Kalamazoo, Mich., and is moving into it. Most of its stock and uncompleted cars have arrived in the new plant or are on the way by express and freight. In the new plant there is sufficient room for expanding the output, as 83,000 sq. ft. of floor space has been secured. In addition, labor conditions are better in Kalamazoo than in Streator. The Barley executive offices will be moved by the middle of March, it is thought.

Twenty-seven Companies Averaged 40,000 Tires Daily

Last year the 27 rubber companies of Akron manufactured rubber products valued at \$188,000,000, according to Dr. W. C. Geer, director of processes of the B. F. Goodrich Rubber Co., in an address before the Cleveland Engineering Society, February 17. He said the output of these rubber concerns was 40,000 tires daily. Dr. Geer predicted that within two years the rubber business would replace a large part of the leather business, and that shoes now made of leather would be made of rubber.

Would Regulate Truck Weight

City Solicitor Chase, of Providence, R. I., is preparing an act to regulate the weight and speed of automobile trucks using the public highways in that city and an effort will be made to have the act passed at the present session of the legislature.

The commissioner of public works of Providence has compiled figures claiming to show that the cost of maintenance in connection with the city highways has increased 400 per cent since the use of big trucks has become general.

Carmody American Production Manager

J. A. Carmody succeeds J. C. Spears as production manager of the American Motors Corp., Plainfield, N. J. At a special meeting recently in Richmond, Va., the following were elected officers of the company: President, W. H. Hoople; vice-president, Louis Chevrolet; treasurer, G. F. Baright; and secretary, P. W. Hansl. Mr. Carmody was formerly chief engineer of the Wagner-Ward Leonard Co., and was consulting engineer of the General Electric Co.

Wage Increase at Stutz Plant

The Stutz Motor Car Co., Indianapolis, Ind., has announced an increase of 10 per cent in wages to all men working in the factory by the hour. Over 350 employees will be benefited by this, and it will mean that more than \$30,000 will be added to the present yearly payroll. The increase became effective March 2.

Another Bumper License

Following the adjustment of the Discher and other bumper cases by the interchange of licenses between ten firms, the U. S. Auto Bumper Co., of Chicago, has also issued licenses to the ten. By these concerns, in turn, licenses have been issued to the U. S. company, upon a mutually satisfactory basis.

Special Bodies for Motor Trucks

With the transition from horse-drawn vehicles to commercial cars there is every reason why more thought should be given to bodies designed not only to attract attention, but to increase the convenience of their use. The day has passed when the same form of wagon should be used for handling all kinds of merchandise. The baker, the grocer, the department store and all other trades can more readily than ever before have their specific needs considered.

The value of individuality in the delivery cars of different merchants goes without saying. It does not necessarily mean that the car must be a freak, although obviously, the more striking the design, the greater will be the impression that it will make.

It is very evident that a big field exists for builders of special bodies, particularly if they can undertake to do the work on such a scale as to turn them out for a moderate price. Few of us but remember the old gabled sign wagons dragged through the streets for no other purpose than advertising. If there was profit in such a practice, certain it is that with a wagon or car performing the useful purpose of delivering goods at the same time, whatever this advertising amounted to it would at least cost nothing beyond the interest on the investment in the body.

One of the greatest hindrances to the more extended use of special bodies has been their cost. Built to order by the local carriage and wagon works, as horse-drawn vehicles have been for years, they naturally may cost four or five times as much as a standard design. The local men cannot dispose of more than one body of each special pattern because the greatest advantage of most special bodies is lost if they are duplicated in any given city. Reduction of cost by quantity production is therefore out of the question for local body builders, but those doing a national business can make a number of each design of body even though they still sell only one in a locality. These builders have a big opportunity.—The Commercial Car Journal.

Rebate for Use of Wide Tire Suggested

Wide tires do not destroy road surfaces as much as do narrow ones; in fact, beyond a certain width, they actually help keep the roads in condition, if they be of earth, clay, macadam or similar construction. Hence the proposal of Col. Frank W. Buffum, Missouri state highway commissioner, to pay those who use wide-tired vehicles. He suggests giving a rebate of \$2 per wheel in 1917, \$1.75 in 1918, and 25 cents less annually until \$1 is reached in 1921; in 1926 he would make wide tires compulsory. Checks for the rebates would be taken as part payment of taxes.

How to Rim a Heavy Wheel

To rim or "ring-up" a heavy cart wheel, presuming the spokes are already tanged, first prepare a felloe pattern of ½ in. board, giving it a little less compass than the true arc of the wheel, as determined by the following rule from Horseshoers' Journal:

For every foot the wheel is in height add ¼ in. to the diameter of the circle for the pattern up to 3 ft., and from that height to 5 ft. 6 in. add ⅜ in. per foot. Procure the felloes ready sawn out to as near the required size and sweep as possible, face them on one side, correcting

any winding there may be and gauge and dress to thickness. Then mark out to pattern and dress the belly to the line, leaving the sole a little full. The length of the felloe is generally obtained by placing it over three spokes close up to the shoulders and marking it at the center of the two outer spokes; or the length can be obtained by multiplying the diameter of the wheel by 3.1416 and dividing by the number of felloes, setting off the length obtained with the tape on the sole of the felloe.

Standard Width for Wagon Tires

As the result of a long series of traction tests on earth and gravel roads, the U. S. Department of Agriculture recommends in Circular 72, of the Office of Secretary, that the following widths of tire be adopted generally by manufacturers for wagons of different carrying capacities:

Type of Wagon	Gross weight Loaded, lbs.	Width of Tire, in.
One-horse wagon.....	2,000	2
Light two-horse wagon.....	3,500	2½
Medium two-horse wagon.....	4,500	3
Standard two-horse wagon.....	6,800	4
Heavy two-horse wagon.....	7,500	5

These five types, says the circular, should be sufficient to meet all the needs of farming operations and general work, except the heaviest trucking and certain specialized hauling which is likely to be confined to city pavements. The circular recommends, therefore, that a name be adopted for each of these sizes and that the wagons be designated, not by the sizes of skein, but according to their gross load capacity. The gross carrying capacity of the wagon should be shown, it is said, by stencil or plate on the back of the rear axle. The size of skein for the five types of wagon named vary from 2½ or 2⅝ in. for a one-horse wagon to 3½ in. for the heavy two-horse wagon.

Auto Business in Canada

There are now 12 Canadian automobile concerns in Canada, with an estimated output for 1917 of \$50,000,000. In addition there are tire concerns, oil companies, wood-working companies and wheel and body building concerns. Each of these adds to the turnover, which, it is safe to say, counting subsidiary industries, will do a total business in 1917 of not far below \$100,000,000.

During 1916, statistics show that 116,365 automobiles and commercial cars were registered in Canada. At the end of 1914 there were only 63,223; at the end of 1915, 83,147. This means that 33,218 cars were added to the national total in 1916, an increase of 40 per cent. Taking \$1,250 as the average price paid for an automobile or truck, the total expenditure of the Dominion for cars in operation today represents a capital investment of \$150,000,000.

Causan Leaves Chalmers

Nemorin Causan, the French motor car engineer, who has been employed in the drafting room of the Chalmers company, Detroit, has resigned his position and will return to France. Mr. Causan suffered a severe illness from gas while serving in the European war and returns for medical treatment. He is the designer of many famous racing cars and was formerly editor of the Technique Automobile.

Trade News From Near and Far

General News of the Vehicle Trade

Columbia Motors Co., Detroit, is planning the erection of a factory to be started at once.

Campbell Transmission Co. has been organized at Buchanan, Mich., with a capital of \$250,000.

Plant owned by the Kelsey Wheel Co., Windsor, Ont., was damaged by fire with a total loss of \$10,000.

Addition to the plant of the Maxwell Motor Car Co., Dayton, O., will be of fireproof construction, estimated to cost \$50,000.

Hayes Machine Co., Oshkosh, Wis., has established a department for the manufacture of automobile and motor truck axles.

John Redmond and A. Hanshaw, Detroit, will establish a factory at Lapeer, Mich., to manufacture steel axles and wagon tongues.

Emerson Motor Co., Kingston, N. Y., has completed plans for a molding room, 100 x 200 ft., one story, which it will erect at a cost of \$20,000.

Factory building to be erected by the Jamestown Auto Parts Mfg. Co., Jamestown, N. Y., will be 80 x 127 ft., two stories. Oscar Lenna is president.

Hayward Automobile Co., Hayward, Wis., is installing new machine shop equipment to meet largely increased demands for automobile and commercial work.

Kent Motors Corporation, Belleville, N. J., has filed plans for a new building, 50 x 200 ft., to be erected at its automobile factory now in course of construction.

Motors Products Corporation, Detroit, has issued a \$1,000,000 note to create a fund for the purchase of the old Lozier plant which the company now occupies.

Baynes Carriage Co., Ltd., Brantford, Ont., has been incorporated with a capital stock of \$50,000 by James Harley, Edmund Sweet, Archibald M. Harley and others.

Warner Gear Co., Muncie, Ind., manufacturer of automobile parts, has announced that in the early spring it will erect new buildings and increase the capacity of its plant.

Dartt Carriage & Automobile Co., Wellsboro, Pa., has been incorporated with a capital of \$25,000, to manufacture carriage and automobile parts. Robert R. Dartt is president.

Hayes Motor Truck Wheel Co., St. Johns, Mich., is installing new dry kilns and machinery. Additional buildings will be started soon. C. B. Hayes, Jackson, Mich., is president.

Crow Motor Car Co., Mount Brydges, Ont., is making preparations for the erection of a plant to cost \$100,000. A. Eisenbach is manager. The new plant is to be erected at London, Ont.

Halladay Motor Car Co., Mansfield, O., has been incorporated, capital \$1,000,000, to manufacture automobiles, by T. E. Huth, Y. F. Stewart, J. N. Horne, Geo. B. Stacey and E. D. Baxter.

Wiberg Wagon Mfg. Co., of Minneapolis, is a recent incorporation. It has a capital stock of \$50,000. The in-

corporators are Charles A. Wiberg, Victor B. Wiberg and Carl H. Leaf, all of Minneapolis.

Automobile Dump Car Co., South Bend, Ind., has been incorporated with \$25,000 capital stock to manufacture automatic dump cars. The directors are P. C. Fergus, Mason L. Petro and A. L. Herr.

The manufacture of buggies has been discontinued by the Durant-Dort Carriage Co., Flint, Mich. The plant is now occupied by its successor, the Dort Motor Car Co., which is manufacturing the Dort automobile.

Mitchell Motors Co., Racine, Wis., has under way large additions to its plant, particularly machine shop and body building. A considerable increase in the production of the company is contemplated for the ensuing year.

Van Dorn-Dutton Co., Cleveland, O., manufacturer of automobile gears, will shortly extend its line in this field by the manufacture of complete differentials for automobiles weighing from 2,800 to 3,600 lbs. and up to 60 h.p.

Ford Motor Co. will give up its Long Island City plant in about a year. The company has started to build at Kearny, N. J., and is now laying the foundation for a dock for export business. When completed operations in the Long Island City plant will be transferred to Kearny.

Wisconsin Motor Mfg. Co., Milwaukee, Wis., manufacturer of motor car, truck, tractor and aviation engines, has increased its capital stock from \$350,000 to \$1,000,000 and started work on plans for enlargement of its work, which will make possible an increase of from 50 to 75 per cent in its output.

Lutz Motor Co., Buffalo, N. Y., has been recently incorporated with a capital stock of \$200,000 by L. R. Lupton, G. H. Lutz and J. H. McLean, 285 Delaware avenue, and has established temporary offices at 15 Dun Building, Buffalo. It is planning the manufacture of a steam automobile, but is not yet ready to make public its plans.

Olympian Motors Co., Pontiac, Mich., which now occupies the plant constructed for the Flanders Mfg. Co., has purchased the five factory buildings of the Cartercar plant, totaling 225,000 ft. of floor space, and will take possession April 1. The company has also purchased 15 acres of adjoining land, and proposes to erect an assembling building, 100 x 800 ft. R. A. Palmer is president.

Doings of the Motor Truck Builders

Dodge Bros., Detroit, plan manufacturing a light delivery truck, according to reports.

Commercial Car Unit Co., Philadelphia, Pa., will establish an assembling plant at Columbus, O.

Van Winkle Motor Truck Co., Atlanta, Ga., will incorporate in Tennessee with \$50,000 capital stock and establish a plant in Chattanooga.

Brazil Motors Co., Brazil, Ind., is to buy the plant of the Brazil Fence Co. The company plans to make 100 Oversmith-Brazil front-drive trucks a month.

Lowell (Ind.) Truck Co. has been organized to manu-

facture motor vehicles and accessories. The directors are Carlos A. Kenney, Thomas Grant and Leslie H. Geist.

Collier Motor Truck Co., capitalized at \$150,000, will locate at Sandusky, O. The removal from Painesville, O., will take place at once. The company employs 100 men.

Wright-Hibbard Industrial Electric Truck Co., Buffalo, has been incorporated with a capital stock of \$300,000, by R. F. Hibbard, G. A. and W. H. Wright, 48 South Division street.

Moreland Motor Truck Co., 1701 North Main street, Los Angeles, Cal., manufacturer of automobile trucks, is planning the erection of a new plant at Alhambra to cost about \$200,000.

Universal Motor Truck Co., Indianapolis, Ind., has been incorporated with \$30,000 capital stock to manufacture motor vehicles. The directors are F. C. Duncan, E. Dawson and Z. E. Keller.

Ground has been broken for an addition to the Selden factory in Rochester, N. Y. The new building will give the factory an additional space of 14,000 sq. ft., extending west of the present plant.

Kerosene Motor & Tractor Co., St. Louis, has been incorporated with a capital stock of \$10,000 by George P. Weber, James M. Leonard and G. C. Weber, to manufacture motor vehicles and trucks.

Diamond T. Motor Co., Chicago, builder of motor trucks, has contracted for the building of a manufacturing plant to be located in Kilbourne avenue, to cost \$1,000,000. C. A. Tilt is president and treasurer.

Motor trucks in two and four-ton models are now being built by the J. C. Wilson Co., Detroit, known for years as body builders. The trucks have four-cylinder engines, 144 in. wheelbase, ample clearance and are exceptionally sturdy.

Ground will be broken soon after April 1 for the first unit of the new motor truck plant of the Winther Motor Truck Co., Kenosha, Wis. The first shop building will be 110 x 400 ft. in size, one story, of fireproof construction, with sawtooth roof.

Ton-A-Ford Co., Racine, Wis., organized to manufacture light motor trucks embodying the Ford chassis, is now in its new plant, the buildings formerly occupied by the Perfex Radiator Co. The daily capacity will be 25 to 30 units. The extension chassis retails at \$345.

A new model $\frac{3}{4}$ -ton Denmo truck will be placed on the market by the Denneen Motor Co., Cleveland, O. The company is arranging to take over a tract of 19 acres of land on which a new factory will be built. The factory is behind its orders, making new facilities necessary.

Southern Truck & Tractor Co., of Nashville, Tenn., has been incorporated with a capital stock of \$10,000. The incorporators are: John R. Boxley, Elbert Sullivan, Jr., J. M. Smithson, F. M. Ferris, W. B. Chambers. The company will buy, sell and deal in trucks and tractors.

Durable Motor Truck Co., just organized at Hammond, Ind., capital \$500,000, has purchased a factory building and will commence at once manufacturing small trucks. Officers are: Joseph Studer, of Whiting, president; Charles A. Foss, of West Hammond, treasurer, and C. Brown, secretary.

During January the Packard Motor Car Co. sold over \$2,000,000 worth of trucks. These figures represent the value of Packard trucks for use of American business

men only—no foreign orders, samples or demonstrators are included. Also every dollar was for chassis only, most buyers having bodies built by outside firms.

Noble Motor Truck Co., just organized at Kendallville, Ind., capital \$30,000, will manufacture a standardized motor truck having a capacity of two tons. The manufacture of smaller and larger trucks will also be the aim of the new company. C. J. Munton is president; H. L. Postel, vice-president; G. M. Patterson, secretary, and H. W. Bradtmiller, treasurer.

Emerson Co. of Texas, Fort Worth, has been organized with a capital stock of \$50,000 to assemble automobile trucks and tractors. It will have a floor capacity of 36,000 sq. ft. The officers of the company are: J. P. Price, president; Marshall Spoons, first vice-president; B. F. Pettit, of Maypearl, second vice-president; and O. B. McCoy, secretary and treasurer.

United States Motor Truck Co., Cincinnati, O., has received an order from France for its five-ton trucks. Shipments are to be made at the rate of 20 trucks a month, and the company states that the machines are for commercial purposes only. The company has also been awarded a contract to supply the national postoffice department at Washington with motor trucks.

Dayton (O.) Motor Truck Co. has been organized by J. M. Dunwoodie, Barry S. Murphy and others to take over the plant of the Durable Dayton Truck Co. and resume the manufacture of trucks of from 2 to $7\frac{1}{2}$ tons capacity, both worm and chain-driven types. A three years' contract has been closed with Melchor, Armstrong & Dessau Co. to handle the company's trucks in foreign countries.

Oneida Motor Truck Co. has been organized at Green Bay, Wis., with \$300,000 capital to manufacture a new truck in 1, $1\frac{1}{2}$, 2, and $3\frac{1}{2}$ -ton sizes. The concern contemplates large production eventually. Factory facilities have already been provided. G. A. Lindstrom, formerly superintendent of the Menominee concern, is factory superintendent. His pneumatic radiator shock absorber will be incorporated in the trucks to be built.

Fulton Motor Truck Co., Farmingdale, L. I., N. Y., which brought out a $1\frac{1}{2}$ -ton internal gear drive truck last year, has placed orders for the erection of an addition to the plant. This will have 40,000 sq. ft. of space, and will practically double the capacity of the plant. Building materials already are arriving on the ground and construction is to start at once. The company plans to make 2,000 trucks during 1917, and at present is operating the plant 24 hours a day.

Chamber of Commerce, Wausau, Wis., has raised a fund of \$65,000 to provide a plant and equipment for the Lamson Motor Truck & Tractor Co., Chicago, which has agreed to move from Chicago. The chamber is taking bids for sites of five acres or more as a location of the new plant. The main building will be 200 x 300 ft., one story and part basement, with sawtooth roof, of reinforced concrete and brick, and is to be completed June 15. J. N. Manson is chairman of the committee in charge.

Redden Motor Truck Co., 1442 South Michigan avenue, Chicago, has been incorporated with a capital stock of 200,000 shares of no par value, and stock will be issued to bring the company an initial working capital of about \$1,000,000. The board of directors will consist of a number of New York and Chicago bankers. Manufacturing

plans are to build 25,000 one-ton trucks during 1917 for attachment to a Ford chassis. C. F. Redden is president. The company will also adapt its trucks for attachment to other automobile chassis.

Federal Motor Truck Co., Detroit, has put five new models on the market, ranging from one to five tons, and two of these are new, the one and five ton models. The 1½, 2 and 3½ ton models are new models also, but are refinements of the previous designs. There are a few differences necessitated by the difference in capacities. The most notable is that the trucks all have four-speed gear boxes except the one-ton truck, which has three speeds. The five-ton model is equipped with steel wheels with hollow spokes, the smaller models with artillery wood wheels. The price of the chassis are as follows: 1-ton, \$1,650; 1½-ton, \$2,100; 2-ton, \$2,300; 3½-ton, \$3,000; 5-ton, \$4,000.

Body Builders Briefs

Portland (Ind.) Body Works will erect a three-story factory costing \$15,000.

Ionia Auto Body Co. has purchased one of the plants of the Heinz Pickle Co. at Grand Rapids, Mich., for \$85,000 and will move there in the near future.

Wright Carriage Body Co., Davenport, Ia., is planning the immediate construction of a one-story brick addition to its body assembling department, to cost \$7,500.

FitzGibbon & Crisp Co., Inc., Trenton, N. J., recently extended their activities to the building of steel hand and power dump bodies for builders and contractors.

Frank Bros. Iron & Metal Co., Detroit, has purchased the plant of the Victor Mfg. Co., Detroit. The buildings are well suited for the manufacture of automobile bodies.

C. R. Wilson Body Co., Detroit, has secured the plant of the Hargreaves Mfg. Co. and will use the 80,000 sq. ft. of floor space it contains for making closed bodies of every type.

Mack Body Co., Camden, N. J., has been incorporated with a capital of \$125,000 to manufacture carriages and wagons. Edward, John and L. E. McLaughlin are the incorporators.

Goodman Auto Body Co., 1737 Broadway, New York City, Henry Goodman, president, has increased its capital stock from \$5,000 to \$25,000. This company manufactures special automobile bodies.

Herman C. Maise, chief engineer of the Springfield Body Co., Springfield, Mass., and Detroit, has resigned. He entered the automobile industry from the carriage industry, for which he was a body designer.

L. J. Eshleman heads the Dale Body Co., the new auxiliary to the Allen Motor Co., Fostoria, O. The other officers are: Vice-president, Fred Freese; second vice-president, Frank Kingseed; and treasurer, M. A. Thomas.

Harroun Motors Corp. has contracted with the Briggs Mfg. Co. for the assembling and trimming of Harroun's bodies. The Briggs Mfg. Co. will use a portion of the old Prouty & Glass carriage plant at Wayne, Mich., for this purpose.

It is reported, but not officially confirmed, that the Sayers & Scoville Co., Cincinnati, O., maker of automobile bodies and other specialties, is having plans prepared for an addition to its plant that will more than double its present capacity.

Chicago Auto Painting Co., 2441 South Michigan avenue, Chicago, will build a three-story factory at Michigan avenue and 24th street. This concern, besides painting automobile bodies, also builds new bodies, on which their trade is rapidly expanding.

Harry L. Bill has resigned as vice-president and general manager of the Springfield Body Corp., Detroit. Continued ill health and illness and death in his family made the step necessary. He intends to take an extended vacation in order that he may regain his health.

Blue Ribbon Body Co., Bridgeport, Conn., has been incorporated with authorized capital stock of \$500,000, to manufacture automobile bodies. It will begin business with 254,400. The incorporators are E. A. Godfrey, Geo. H. Woods and L. J. Godfrey, all of Bridgeport.

Fisher Body Corp., Detroit, from the date of incorporation, August 21, 1916, to November 30, 1916, shows, according to a recent report, a surplus available for common stock for those three months of \$639,000, equal to \$3.20 a share on 200,000 shares of common stock.

Clark Carriage Co., Oshkosh, Wis., is being reorganized and some new equipment will be purchased for the manufacture of metal and wood automobile and truck bodies. The manufacture of horse-drawn vehicles will be continued. H. M. Foulke will continue as general manager.

Janesville (Wis.) Carriage Works recently reorganized and will remodel its plant to build motor bus and motor hearse bodies on a production basis. A repair department will be maintained. C. A. Buchholz is president and general manager, and Frank D. Hayes will have charge of the offices.

Gravity Dump Body Co., Detroit, Mich., manufacturer of gravity dump bodies for motor trucks, which was organized last August, has commenced production. The bodies, which are made in various sizes from one ton capacity upward, are of the hopper type and dump by rolling to the side of the chassis.

Porter Body Co., capital \$30,000, succeeds the Globe Truck Co., Ypsilanti, Mich., and is manufacturing bodies, trailers and parts in a leased factory. A new building is to be erected as soon as the weather allows. Officers: David Killins, president; G. E. Roiter, vice-president; G. Killins, treasurer, and B. Killins, secretary.

Briscoe Co. has placed an order for 5,000 bodies with the All Season Body Co., recently organized and which took over the plant of the Page Bros. Buggy Co., at Marshall, Mich. The officers of the All Season Body Co. are: W. L. Page, president; J. A. McAvoy, vice-president; E. E. Page, secretary; W. J. Dibble, treasurer.

Appleton (Wis.) Auto Body Co., organized several months ago to manufacture all kinds and types of car and truck bodies, already has been obliged to increase its capacity. The company has purchased the factory group at Fremont and Jefferson streets, which now is being rebuilt into a modern body-making and finishing shop.

Brown Auto Carriage Co., one of the largest automobile body concerns at Cleveland, O., is to increase its capital stock to \$750,000. It is the intention of the company to build a body plant large enough to take care of the business which it heretofore has been compelled to refuse owing to limited factory facilities, and which has been going out of Cleveland.

Racine Mfg. Co., Racine, Wis., has been obliged to place its factory on a regular night shift to handle the large

volume of orders for taxicab and other special bodies now being booked. The output has been increased to 80 touring car bodies and 15 closed bodies daily. The concern is now working on a renewal order for 75 taxicab bodies for the Walden W. Shaw Delivery Co., Chicago and New York. The company is also licensed to manufacture Springfield closed bodies. It has been found necessary to eliminate all custom work in order to accommodate the demands of the regular contracting customers.

Oxford (N. C.) Body Co. has been organized to take over and operate the Excelsior Seat Co.'s plant located in the suburbs of Oxford, and which was operated by the Excelsior Seat Co., of Columbus, O., as their southern branch until the European war interfered with that line of business. The plant was closed down for two years. The new company will build a complete line of buggy bodies and seats for the trade, and later will turn their attention to the manufacture of automobile bodies. The officers are: C. W. Bryan, president; W. B. C. Hersey, vice-president; Charles O. Mainor, secretary and general manager, and C. S. Garman, treasurer and sales manager.

Death of Joseph V. Collings

Joseph V. Collings, Camden, N. J., died February 21 of nervous troubles and general debility due to his advanced years. Mr. Collings was a son of Jacob S. Collings, who founded the Collings Carriage Co. in Camden in 1827. After the father's death, Joseph V. and Thomas F. Collings carried on the business, from 1862 to 1877, when Joseph V. Collings absorbed his brother's interest. Twelve years ago Mr. Collings retired, leaving the management of the business to his sons. He is survived by his widow, three sons and five daughters. The Collings Carriage Co. has for a number of years been engaged in building high class automobile body work.

Death of Charles Rowland

Charles Rowland, 65, vice-president of the firm of William & Harvey Rowland, spring manufacturers, Franklin, Pa., died February 9 at his home, Philadelphia.

WANTS

Help and situation wanted advertisements, 1 cent a word; all other advertisements in this department, 5 cents a word; initials and figures count as words. Minimum price, 30 cents for each advertisement.

PATENTS

Patents—H. W. T. Jenner, patent attorney and mechanical expert, 606 F St., Washington, D. C. Established 1883. I make a free examination and report if a patent can be had and exactly what it will cost. Send for circular.

FOR SALE

For Sale—"Motor Body Work for Commercial Cars," a new text book dealing with the construction of all types of bodies for business purposes. Contains also six working drawings and a glossary of technical terms, together with diagrams and sketches. Price, \$1.20 net; by post, \$1.56. Orders should be accompanied by remittance. Cooper's Vehicle Journal, Ltd., 19 Garrick street, Long Acre, London, England.

HELP WANTED

Salesman—Young man to cover territory adjacent to New York City, familiar with carriage, wagon and automobile repair shop jobbing trade. Address, Box 13, The Hub, Elm and Duane streets, New York City.

Index To Advertisers

Acme Die-Casting Corporation..... 38
 American Motors Corporation..... 6
 Barrell Co., Wm. L..... 4
 Beja Body Co., The..... 39
 Bliss, E. W., Co..... 3
 Bookwalter Wheel Co..... 42
 Bradley, C. C., & Son..... 41
 Brawley, T. R..... 43
 Brennan Motor Mfg. Co..... 43
 Columbus Bolt Works..... Back cover
 Cowles, C., & Co..... 42
 Crane & MacMahon, Inc..... Back cover
 Decker, J. C..... 42
 Dowler, Chas. L..... 42
 DuPont Fabrikoid Co..... 4
 Eccles, Richard, Co..... 42
 Hoopes Bro. & Darlington..... 43
 Hotel Brunswick 41
 Hotel Tuller 38
 Jenner, H. W. T..... 37
 Johnston, R. F., Paint Co..... 42
 Keratol Co., The..... 4
 Laidlaw Co., The..... 2
 Lumen Bearing Co..... 3
 Merriam Co., G. & C..... 38
 Millersburg Fifth Wheel Co..... 42
 Mulholland Co., The..... 42
 Murcott-Duden Co., The..... 2
 Parsons Mfg. Co..... 2
 Pettingell Machine Co..... 7
 Porter, H. K..... 43
 Pressed Steel Co. of New York..... 2
 Rome-Turney Radiator Co..... 40
 Russell, Burdsall & Ward Bolt & Nut Co..... 41
 Sheldon Axle & Spring Co..... Front cover
 Skinner, J. M., Bending Co., The..... 38
 Smith, H. Collier..... 43
 Sherwin-Williams Co., The..... 8
 Standard Oil Cloth Co., Inc..... 5
 Technical School for Automobile Draftsmen..... 41
 West Tire Setter Co..... 43
 White-Quehl Mfg. Co..... 42
 Wilcox Mfg. Co., D..... 43
 Willey Co., C. A..... 42
 Williams, J. H., & Co..... 8
 Wing, Chas., Co..... 42
 Yoder Company, The... .. Back cover

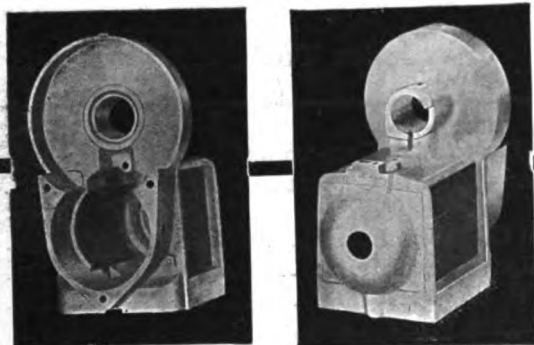

Front view

Back view

**Magneto Housing Cast in One Piece
Example of Acme Die-Casting**

Service to the Automobile Trade

The Magneto Housing shown here was promised in seven weeks. We made the die, submitted samples—made a few minor changes—completed and delivered the castings to the customer satisfactorily. They were accurate, smooth, clean, free from blow holes, rough marks or other imperfections. Our patented process permits of the widest range of work in

Aluminum or White Metal Alloys

Our thorough organization of engineers and complete shop equipment enables us to give you the most efficient service. Send Model or Blue Print now for estimate.



Acme Die-Casting Corporation
 Bush Terminal Bldg. No. 5, 57th St. and 3d Ave.
 Brooklyn, N. Y.

Boston—176 Federal St.
 Philadelphia—Widener Bldg.
 Detroit—965 Woodward Ave.
 Chicago—549 Wash. Blvd

CANADIAN DISTRIBUTORS:
 Lyman Tube & Supply Co., Ltd., Montreal

Bent Rims—Bent Rims—Bent Rims—Bent Rims—Bent Rims—

OAK AND HICKORY

BENT RIMS

of QUALITY

**For Carriage, Wagon or Automobile
Wheels**

THE J. M. SKINNER BENDING COMPANY

TOLEDO - - - OHIO

One of the oldest and largest Rim Manufacturers in the
U. S. A.

Bent Rims—Bent Rims—Bent Rims—Bent Rims—Bent Rims—



Meet me at the Tuller for Value, Service, Home Comforts

NEW
HOTEL TULLER
 Detroit, Michigan

Center of business on Grand Circus Park. Take Woodward car, get off at Adams Avenue.

ABSOLUTELY FIREPROOF

200 Rooms, Private Bath,	\$1.50	Single,	\$2.50	Up Double
200 " " " "	2.00	" "	3.00	" "
100 " " " "	2.50	" "	4.00	" "
100 " " " "	3.00 to 5.00	" "	4.50	" "

Total, 600 Outside Rooms

ALL ABSOLUTELY QUIET

Two Floors—Agents' Sample Rooms

New Unique Cafes and Cabaret Exellente

The One Supreme Authority—
WEBSTER'S NEW INTERNATIONAL

The *New Creation* is an all-knowing special teacher answering with *final* authority all kinds of puzzling questions in spelling, pronunciation, definition, history, geography, biography, sports, arts, and sciences.

400,000 Vocabulary Terms. New Gazetteer.
12,000 Biographical Entries. 2700 Pages.
Over 6,000 Illustrations. Colored Plates.

The One Supreme Authority. It is the standard of the Government Printing Office. The standard of nearly all of the schoolbooks. *Indorsed* by State, School Superintendents. *All States* (30 in number) that take official action regarding the adoption of dictionaries recognize the Merriam Series as authoritative.

Write for specimen pages. **FREE**, a set of pocket maps if you mention this publication.

← **Regular and India-Paper Editions.**

G. & C. MERRIAM CO., Springfield, Mas.
GRAND PRIZE (Highest Award) Panama Pacific Exposition

Please mention "The Hub" when you write.

New and Distinctive High Grade Closed Auto Bodies of Aluminum



ANNOUNCEMENT!—The Bela Body Company, of Framingham, Mass. (recently organized under Massachusetts laws), have purchased one of the finest manufacturing plants in the east, and are completely equipping it for every detail of fine Automobile Body work.

OUR SPECIALTY—We specialize in High Grade Closed Bodies of new styles and types. Already a number of the large automobile manufacturers have had us design and build Special Fine Closed Bodies

OUR EXPERTS—Our Mr. Bela, the first man in the U. S. to use an Automatic Metal Bumping Machine, is recognized as the most expert Sheet Aluminum Worker in this country. Many of the best operators owe their success to his personal instruction. Each of the men associated with Mr. Bela is a master workman—all are experts in the various departments of body building.

LEADING MANUFACTURERS in the trade are turning to us for exclusive designs and strikingly distinctive high class bodies. They realize the sales value that such bodies give to their cars, for no one denies that

Bela Bodies Show "Class"

HIGH RECOGNITION—When the leading automobile manufacturers in the country buy bodies from us—comment is unnecessary. Note the Liberty Brougham shown above. The body of this stylish Town Car or Ladies' Shopping Brougham made an instant hit. It is causing more favorable comment and selling better than any other style body for years. It is unquestionably one of the lightest, strongest and most attractive bodies ever built. Observe its compactness, its clean cut graceful lines, its handsome appearance.

ONE-PIECE CONSTRUCTION—Particular attention is called to the fact that this unique body is made entirely of Aluminum, without any seams or belt line irons (belt line rolled in). Not a seam or a joint to open or crack. The roof, sides, back—everything being without seam. This construction eliminates much weight in the belt line irons and fasteners, as it does away with these entirely.

Our Paint Department, shown opposite, is the lightest and best in the country. Our Trimming Department is a model manufacturing building. The entire building is fire-proof.

LOCATION—On the main line of two railroads, within easy reach of Boston, New York, Springfield, Worcester and Providence, via state roads or railroad. When you want BODIES that will help SELL YOUR CARS—let us build them.

**THE BELA
BODY CO.,**
Framingham,
Mass., U. S. A.



ROME-TURNEY

units represent extremely advanced engineering. We have built radiators of all types for 14 years and are specialists in designs developed for truck construction. No better radiators can be built. If this were possible we would build them.

"RADIATOR INSURANCE"

SEAMLESS COPPER HELICAL
TUBE COOLING SECTIONS

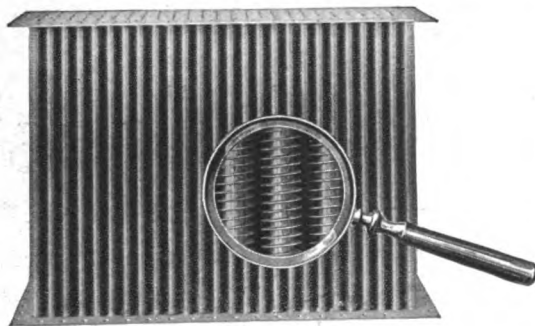

*Are Guaranteed for the Life of the
Motor on Which They are Installed*

*Helical Tube Construction is Accepted as the
Best by the Leading Truck Makers of America*

MANUFACTURED ONLY BY
ROME-TURNEY RADIATOR COMPANY
ROME, NEW YORK

When you install a

HELICAL TUBE RADIATOR

on your truck, you have the certainty that the radiator will make good or we will. We probably won't have to—

ROME-TURNEY RADIATORS

have a habit of making good themselves. But if the cooling section develops leaks, we will repair it free.

CLASSIFIED INDEX

For Addresses See Alphabetical Index
and Advertising Pages

AUTOMOBILES

American Motors Corp., Plainfield, N. J.

AUTO FABRICS

Barrell, Wm. L., Co., New York
Keratol Co., The, Newark, N. J.
Laidlaw Co., Inc., The, New York
O'Bannon Corporation, New York City
Standard Oil Cloth Co., New York City.

AXLES (Including Ball and Roller Bearing)

Sheldon Axle & Spring Co., Wilkes-Barre, Pa.

BODIES

Bela Body Co., Framingham, Mass.

BOLTS AND NUTS

Columbus (O.) Bolt Works Co.
Russell, Burdall & Ward Bolt & Nut Co., Port Chester, N.Y.

BOLT CLIPPERS

Porter, H. K., Everett, Mass.

BRAZING SLEEVES

White-Quehl Mfg. Co., Cincinnati, O.

BRONZE BEARINGS

Lumen Bearing Co., Buffalo.

DIE CASTINGS

Acme Die Casting Corp., Brooklyn, N. Y.

DIES

Bliss Co., E. W., Brooklyn, N.Y. (Sheet Metal Working).

FORGINGS

Eccles, Richard, Auburn, N. Y. (Carriage, Drop).
Williams, J. H., & Co. Brooklyn, N.Y. (Automobile, Drop)

FIFTH WHEELS

Millersburg Fifth Wheel Co., The, Millersburg, Pa.
Wilcox Mfg. Co., D., Mechanicsburg, Pa.

HARDWARE (Carriage, Wagon and Automobile)

Columbus (O.) Bolt Works Co.
Dowler, Chas L., Philadelphia.
Eccles Co., Richard, Auburn, N. Y.
Wilcox Mfg. Co., D., Mechanicsburg, Pa.
Wing Co., Chas., Amesbury, Mass.
Cowles, C., & Co., New Haven, Conn.
Parsons Mfg. Co., Detroit, Mich

LEATHER SUBSTITUTES

Barrell Co., Wm. L., New York.
Keratol Co., The, Newark, N. J.
Standard Oil Cloth Co., New York.
DuPont Fabrikoid Co., Wilmington, Del.

MACHINERY AND TOOLS

Bliss Co., E. W., Brooklyn, N.Y.
Pettingill Machine Co., Amesbury, Mass.
Smith, H. Collier, Detroit, Mich.
West Tire Setter Co., Rochester, N. Y.
Williams, J. H., & Co., Brooklyn, N. Y.
White-Quehl Mfg. Co., Cincinnati, O.

MACHINERY (Metal Working)

Bliss Co., E. W., Brooklyn, N.Y.
Smith, H. Collier, Detroit, Mich.
Yoder Co., The, Cleveland, O.

METAL STAMPINGS AND NOVELTIES

Murcott-Duden Co., Inc., New York.
Pressed Steel Co. of New York, New York City.

MOTORS

Brennan Motor Mfg. Co. Syracuse, N. Y.

PATENTS

Jenner, H. W. T., Washington, D. C.

PAINTS AND COLORS

Johnston Paint Co., R. F., Cincinnati, O.
Pierce Co., F. O., New York.
Sherwin-Williams Co., Cleveland, O.
Valentine & Company, 456 4th Ave., New York; 343 S. Dearborn St., Chicago; 74 Pearl St., Boston.
Willey Co., C. A., Hunter's Point, N. Y.

PRESSES

Bliss Co., E. W., Brooklyn, N.Y. (Drop, Power).

RADIATORS

Harrison Mfg. Co., Inc., The, Lockport, N. Y.
Rome-Turney Co., Rome, N. Y.

SCHOOL FOR DRAUGHTSMEN

Mechanics' Institute, New York

SHAFT COUPLINGS

Bradley & Son, C. C., Syracuse, N. Y.
Eccles Co., Richard, Auburn, N. Y.

SPRINGS

Mulholland Co., Dunkirk, N. Y.
Sheldon Axle & Spring Co., Wilkes-Barre, Pa.

TOOLS

Williams, J. H., & Co. Brooklyn, N. Y.

VARNISH AND JAPAN

Parrott Varnish Co., Bridgeport, Conn.
Pierce Co., F. O., New York.
Sherwin-Williams Co., Cleveland, O.
Valentine & Company, 456 4th Ave., New York; 343 S. Dearborn St., Chicago; 74 Pearl St., Boston.
Willey Co., C. A., Hunter's Point, N. Y.

WHEELS

Bookwalter Wheel Co., Mtamisburg, O.
Crane & MacMahon, Inc., New York City.
Hoopes Bros. & Darlington, Inc., West Chester, Pa.
Smith Wheel, Inc., (Metal), Syracuse, N. Y.

WOOD BENDINGS, WHEEL STOCK, ETC.

Columbus (O.) Bending Co.
Crane & MacMahon, Inc., New York City.
Skinner Bending Co., J. M., Toledo, O.

BUSY BUYERS BRIEFS



Manufacturers
FIFTH WHEELS
All Varieties
Heavy Goods a
Specialty
Iron and Steel Rings from 4 to
60 inches wide
MILLERSBURG FIFTH WHEEL CO.
Millersburg, Pa.

WE MANUFACTURE
**FINE VEHICLE
WHEELS**
The Bookwalter Wheel Co.
MIAMISBURG, OHIO

**JOHNSTON'S
KRAKNO**
Color Card Free
\$3.50 per gallon
The R. F. Johnston Paint Co.
Cincinnati, Ohio

Why Not Have the Best?

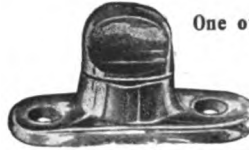

One of a Large Variety
G. Cowles & Co.
NEW HAVEN,
CONN.

J. C. DECKER
MONTGOMERY, PA.
Manufacturer of
Carriage, Skate and Pad Straps
Side Loops, Bridle Fronts, Tail Ties, etc.

THE CHARLES WING CO
Established 1848
Manufacturers and Wholesale Dealers in
**AUTOMOBILE AND CARRIAGE
HARDWARE AND TRIMMINGS**
AMESBURY, MASS., U. S. A.

CHARLES L. DOWLER

CARRIAGE AND WAGON HARDWARE
108 North Third St., Philadelphia, Pa.
CUSHION MANUFACTURER
Pure Stearic Acid Candles. Wheel Stock. Snow
Flake Axle Grease.

**MULHOLLAND
BUGGY SPRING**

Reduces weight of springs one-half.
Made in one size only but will fit bodies
of all widths.
Write for further particulars and prices.
THE MULHOLLAND CO. DUNKIRK, N. Y.



LINED



UNLINED

White's Brazing Sleeves

For applying Rubber Tires
Send for Samples.

WHITE-QUEHL MFG. CO.

431 E. Pearl St.
NATI, OHIO

Subscribe
Now for

THE HUB

**\$2.00
Per Year**

**WILLEY'S
COLORS**

The Recognized Standard



C. A. WILLEY CO.

COLOR GRINDERS

and Manufacturers of Specialties in

CARRIAGE, AUTOMOBILE and CAR

PAINTS

COLORS, VARNISHES, ETC.

HUNTER'S POINT, NEW YORK CITY

High Grade Forgings

for **CARRIAGE, WAGON, AUTO-
MOBILE and SPECIAL WORK**

ECCLES BALL-BEARING COUPLINGS are the **BEST** on the
MARKET for **DURABILITY** and **EASE OF ADJUSTMENT**

LEATHER BUSHINGS ARE FAST-
ENED IN THE SOCKET WHERE
THEY BELONG

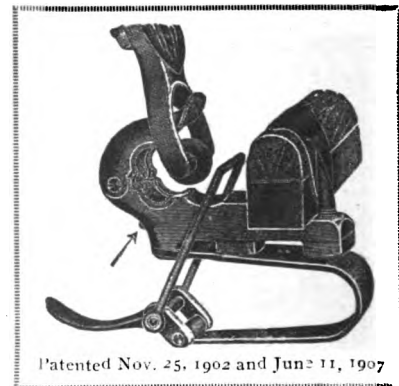

Patented Nov. 25, 1902 and June 11, 1907

**SPECIAL FEATURE—THE SPRING
IS PIVOTED AT THE FRONT TO
ALLOW EASY ADJUSTMENT**

Please bear in mind that we make a **FULL LINE**
of Carriage and Wagon Forgings, also many of
those for Auto and Special Work.

Send for our new Catalogs showing our Regular
and Special Forgings.

QUALITY GUARANTEED.

SERVICE—THE BEST

Richard Eccles Co.

AUBURN, NEW YORK

HOOPES BRO. & DARLINGTON

(INCORPORATED)

WEST CHESTER, PA.

WE ARE MAKING

AUTOMOBILE WHEELS

Forty Years' Experience as WHEEL MAKERS is guarantee we can make good ones.
Will not make any other kind. Try them.

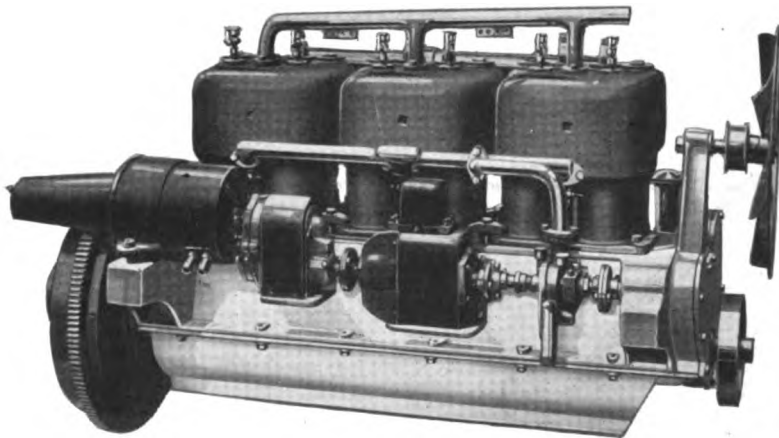

Model 6B Motor, 4½" bore by 5" stroke

Quality and Service

are the two essentials that for 17 years have been built into

BRENNAN STANDARD MOTORS

The manufacturer of Commercial or Pleasure cars who equips his product with Brennan Standard Motors can feel assured his every requirement regarding this vital part has been fulfilled.

Built in the following sizes:

4 Cylinder Model M—4 x 5	4 Cylinder Model 12—½ x 6
4 Cylinder Model B—4½ x 5	4 Cylinder Model 12—6 x 6
4 Cylinder Model 11—5 x 5	6 Cylinder Model 6B—4½ x 5

Let us send bulletins telling WHY Brennan Motors are STANDARD motors

Brennan Motor Mfg. Co., Syracuse, N. Y.

WILCOX

FINE
FINISHED
FORGED

CARRIAGE HARDWARE
AND GEAR IRONS

Write for Prices and Catalog

The D. Wilcox Mfg. Co.

MECHANICSBURG, PA.

The WEST Hydraulic Tire Setter

WILL CUT DOWN EXPENSE

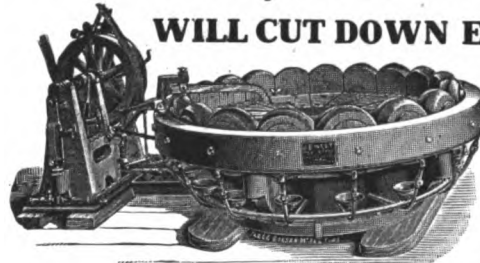

Tires set cold in one minute. This machine saves time—does the work better and quicker, does a way with burned streaks. Only necessary to measure one wheel in a lot. Does not char the rim, and

thus make the tire loosen prematurely. Saves resandpapering of wheels. This machine is now increasing the profits of many manufacturers. Send for catalog and read about it.

WEST TIRE SETTER CO., ROCHESTER, NEW YORK

PORTER'S BOLT CLIPPERS

"Easy" "New Easy" Allen-Randall



To Cut 5-16, 3-8, 1-2, 5-8, 3-4 Inch.

H. K. PORTER, EVERETT, MASS.

"Quickwork"

Sheet Metal
Working Machinery

For Automobile and Carriage Bodies, Fenders, Hoods, etc.

H. COLLIER SMITH

807-815 SCOTTEN AVE. DETROIT, MICH.



We manufacture
FELT AUTOMOBILE WASHERS, GASKETS AND STRIPS
for every requirement.
FORD WASHERS AND GASKET SETS, "Rounds Brand"
for the jobbing trade
LET US QUOTE ON THAT RUSH ORDER

The Hub

AUTOTRUCK

Hickory Nut and

BEST QUALITY STOCK
TOUGH AND HEAVY
BONE DRY

MANUFACTURED BY
CAPABLE MECHANICS
AND MOST
IMPROVED MACHINERY

WHEELS WHICH ADD TO
THE LIFE OF YOUR TRUCK

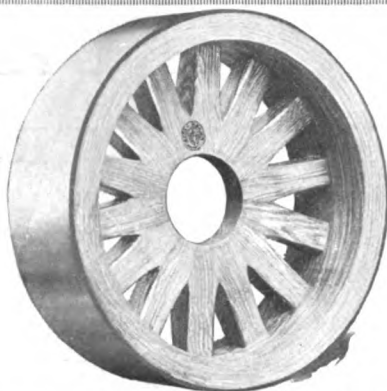

WHEELS

Acorn Brands

HORSE-DRAWN
VEHICLE WHEELS
ALL STYLES

TRAILER WHEELS:
SARVEN AND
ARTILLERY TYPES

HIGH STANDARD OF
QUALITY AND
WORKMANSHIP
MAINTAINED

ST. MARYS, OHIO

CRANE & MacMAHON, Inc.

8 BRIDGE ST., N. Y. CITY

Yoder Sheet Metal Machinery

Yoder
Crown
Rolling
Machine

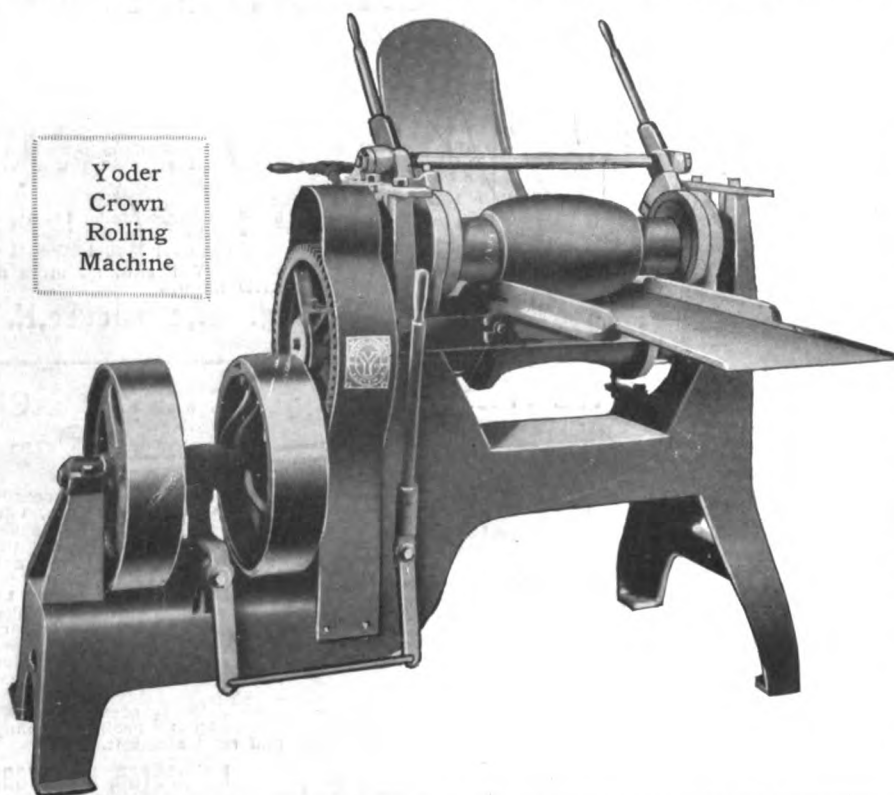

Our line of Auto Sheet Metal Working Machinery is efficient in every detail.

Every machine is constructed with the objective of producing perfect results at a minimum cost of material and labor.

The Yoder Company guarantees its machinery to produce results satisfactory to the purchaser.

We are glad to consider your Sheet Metal Machinery needs, as well as your requirements for special machines.

If you are thinking of making your own sheet metal parts or producing sheet metal products for the trade, get in touch with us at once. We can save you money and furnish a most satisfactory and complete equipment.

Catalog and prices furnished on request

The Yoder Company

Engineers Building

Cleveland - - Ohio

Skewed Shaft Couplings

Regular or Oval Patterns
For High Arched Axles

Furnished in rights and lefts for any height of arch.
Oval Axle Clips $\frac{5}{8}$ or $\frac{3}{4}$ width to match Oval
Couplings. Bolts, Clips, Couplings, Carriage
Hardware and Special Forgings

Catalogue "H" and Prices on Application

COLUMBUS BOLT WORKS COMPANY

COLUMBUS, OHIO

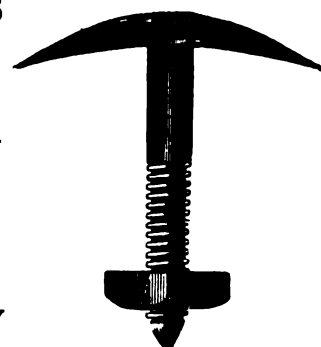
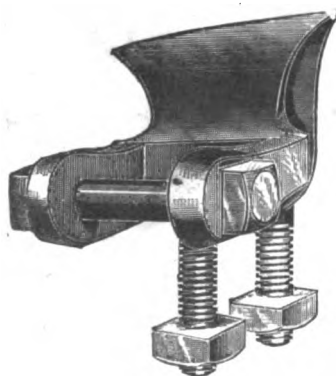

UNIVERSITY OF MICHIGAN
3 9015 08013 4045

